



Agenda
City of Beaumont City Council Meeting
Closed Session 5:00 PM
Regular Session 6:00 PM

Beaumont Financing Authority
Beaumont Successor Agency (formerly RDA)
Beaumont Utility Authority
Beaumont Parking Authority
Beaumont Public Improvement Authority
Community Facilities District 93-1

550 E 6th Street, Beaumont, Ca
Tuesday, May 21, 2019

Materials related to an item on this agenda submitted to the City Council after distribution of the agenda packets are available for public inspection in the City Clerk's office at 550 E. 6th Street during normal business hours.

Any person with a disability who requires accommodations in order to participate in this meeting should telephone the City Clerk's office at (951) 769-8520, at least 48 hours prior to the meeting in order to make a request for a disability related modification or accommodation.

Any one person may address the City Council on any matter not on this agenda. If you wish to speak, please fill out a "Public Comment Form" provided at the back table and give it to the City Clerk. There is a three (3) minute limit on public comments. There will be no sharing or passing of time to another person. State Law prohibits the City Council from discussing or taking actions brought up by your comments.

Page

CLOSED SESSION

A Closed Session of the City Council / Beaumont Financing Authority / Beaumont Utility Authority / Beaumont Successor Agency (formerly RDA)/Beaumont Parking Authority / Beaumont Public Improvement Authority may be held in accordance with state law which may include, but is not limited to, the following types of items: personnel matters, labor negotiations, security matters, providing instructions to real property negotiators and conference with legal counsel regarding pending litigation. Any public comment on Closed Session items will be taken prior to the Closed Session. Any required announcements or discussion of Closed Session items or actions following the Closed Session will be made in the City Council Chambers.

CALL TO ORDER

Mayor Martinez, Mayor Pro Tem Santos, Council Member Carroll, Council Member Lara, and Council Member White

1. Public Comments Regarding Closed Session
2. Existing Litigation Pursuant to Government Code Section 54956.9(d)(1):
City of Beaumont v. McFarlin and Anderson et. al., Case No. RIC1813359
3. Conference with Labor Negotiator - Pursuant to Government Code Section 54957.6 City Designated Representative City Manager Todd Parton or his Designee
 - SEIU

4. Conference with Legal Counsel Regarding Anticipated Litigation and Significant Exposure to Litigation Pursuant to Government Code Section 54956.9(d)(2). Two claims - Alex Guerrero and Alphonso Hatcher, Sr.
5. Conference with Legal Counsel - Anticipated Litigation: Significant Exposure to Litigation Pursuant to Government Code Section 54956.9(d)(2) and/or (3) (one potential case)

Adjourn to Closed Session

REGULAR SESSION

CALL TO ORDER

Mayor Martinez, Mayor Pro Tem Santos, Council Member Carroll, Council Member Lara, and Council Member White

Report out from Closed Session:
Action on any Closed Session items:

Action on any requests for excused absence:
Pledge of Allegiance:
Approval/Adjustments to Agenda:
Conflict of Interest Disclosure:

ANNOUNCEMENTS/RECOGNITIONS/PROCLAMATIONS/CORRESPONDENCE

1. **Presentation from RCTC - State Route 60 Truck Lanes Update** 7 - 17
[RCTC-60TL-BeaumontCC_5-21-19](#)

PUBLIC COMMENT PERIOD (ITEMS NOT ON THE AGENDA)

Any one person may address the City Council on any matter not on this agenda. If you wish to speak, please fill out a "Public Comment Form" provided at the back table and give to the City Clerk. There is a three (3) minute time limit on public comments. There will be no sharing or passing of time to another person. State Law prohibits the Council from discussing or taking actions brought up by your comments.

CONSENT CALENDAR

Items on the consent calendar are taken as one action item unless an item is pulled for further discussion here or at the end of action items.

Approval of all Ordinances and Resolutions to be read by title only.

2. **Ratification of Warrants dated May 2, 2019** 19 - 29
[Item 2](#)
3. **Ratification of Warrants dated May 9, 2019** 31 - 50
[Item 3](#)
4. **Approval of Minutes dated April 25, 2019** 51
[CC Minutes 04.25.19](#)

5. Approval of Minutes dated May 7, 2019	53 - 62
CC Minutes 05.07.19	
6. Tentative Parcel Map 34990 (South of Oak Valley Parkway, East of Interstate 10) One-Year Time Extension	63 - 65
Item 6	
7. A Resolution of the City of Beaumont Authorizing City Council to Summarily Vacate Street Right-of-Way on the Northwest Corner of Grace Avenue and Fifth Street Fronting the Precision Stamping, Incorporated Building	67 - 103
Item 7	
8. Second Reading of Ordinance to Amend Municipal Code Chapters 5.62 and 5.70	105 - 121
Item 8	
9. Fourth Amendment to Tolling Agreement with Norton Rose Fulbright US LLP	123 - 127
Item 9	
10. Third Amendment to Tolling Agreement with Rod Gunn and Rod Gunn Associates, Inc.	129 - 133
Item 10	
11. March 2019 Financial Reports	135 - 142
Item 11	

PUBLIC HEARINGS

Approval of all Ordinances and Resolutions to be read by title only

12. Short Range Transit Plan FYs 2020-2022	143 - 215
Recommended Council Action(s):	
1. Open a Public Hearing and receive any input from key stakeholders; and	
2. Continue the Public Hearing to the June 4, 2019 City Council meeting, allowing the community to give input and make recommendations on the draft plan.	
Item 12	

ACTION ITEMS

Approval of all Ordinances and Resolutions to be read by title only.

13. Legislative Updates and Official City Council Position on Legislative Matters	217 - 261
Recommended Council Action(s):	
1. City staff recommends specific action as follows:	
a. AB392 peace Officers - Deadly Force: take no specific action and continue to monitor,	
b. AB 516 - Authority to Remove Vehicles: oppose,	
c. AB 1332 - Sanctuary State Contracting Act: oppose,	
d. AB 1356 - Cannabis - Local Jurisdictions: oppose,	
e. SB 13 - Accessory Dwelling Units: oppose	

- f. SB 330 - Housing Crisis Act of 2019: oppose,
- g. SB 332 - Wastewater Treatment - Recycle Water: oppose, and
- h. SB 542 - Workers' Compensation: oppose.

2. Provide additional direction to City staff.

[Item 13](#)

14. Staff Report Regarding Sidewalk Vending Regulations 263 - 267

Recommended Council Action(s):

- 1. Receive and file.

[Item 14](#)

15. Receive and File the Oak Valley Traffic Signalization Project Update 269 - 271

Recommended Council Action(s):

- 1. Receive and file the Oak Valley Traffic Signalization Project update.

[Item 15](#)

16. Purchase of a 6.15-Acre Undeveloped Parcel of Land Generally Located at the Southwest Corner of Veile Avenue and Fourth Street - Assessor Parcel Number 417-110-018-3 273 - 289

Recommended Council Action(s):

- 1. This purchase accomplishes important policy objectives of the City and is a cost-effective strategy for meeting the growing service demands of the community. Accordingly, City staff recommends purchasing this property (assessor Parcel Number 417-110-018-3, located at the southwest corner of Veile Avenue and Fourth Street) at the negotiated purchase price of \$2,500,000 and authorize the City manager to finalize the purchase agreement.

[Item 16](#)

17. Fiscal Year 2019-2020 Draft City-Wide Budget and Fiscal Years 2019-2020 through 2023-2024 Listing of Capital Improvement Plan Projects for Review 291 - 304

Recommended Council Action(s):

- 1. Receive and file.

[Item 17](#)

18. General Plan Update Status Report 305 - 307

Recommended Council Action(s):

- 1. Receive and file the General Plan Update status report.

[Item 18](#)

19. Approval of Tyler Technologies Invoices Totaling \$88,146.00 309 - 313

Recommended Council Action(s):

- 1. Approve Tyler technologies invoices 025-255624 and 025-255625 totaling \$88,146.00.

[Item 19](#)

20. Approval for Purchase of Crack Seal Machine 315 - 338

Recommended Council Action(s):

- 1. Approve the Crafcoc quote in the amount of \$80,819.93 to allow the Public Works Department to purchase a crack seal machine.

[Item 20](#)

- 21. Approval for Purchase of Model 742 JLG Multipurpose Telehandler** 339 - 360
Recommended Council Action(s):
1. Approve the purchase of a JGL 742 telehandler with forks, 1.5 yard bucket, and 4x8 man basket not to exceed the amount of \$101,102.02 from West Coast Equipment, LLC.

[Item 21](#)

- 22. Authorize Mayor Julio Martinez to Travel to Sacramento to Attend the Environmental Quality Policy Committee Meeting Scheduled for June 13, 2019** 361 - 373
Recommended Council Action(s):
1. Consideration and review of travel request.

[Item 22](#)

- 23. Reimbursement of Travel Expenses to Council Member Lloyd White** 375 - 376
Recommended Council Action(s):
1. Approve the reimbursement request in the amount of \$45.24

[Item 23](#)

COUNCIL REPORTS

- Carroll
- Lara
- Martinez
- Santos
- White

ECONOMIC DEVELOPMENT UPDATE

Economic Development Committee Report Out and City Council Direction

CITY TREASURER REPORT

Finance and Audit Committee Report Out and Council Direction

CITY CLERK REPORT

CITY ATTORNEY REPORT

CITY MANAGER REPORT

FUTURE AGENDA ITEMS

Adjournment of the City Council of the May 21, 2019 Meeting at ____ p.m.

The next regular meeting of the Beaumont City Council, Beaumont Financing Authority, the Beaumont Successor Agency (formerly RDA), the Beaumont Utility Authority, the Beaumont Parking Authority and the Beaumont Public Improvement Agency is scheduled for Tuesday, June 4, 2019, at 5:00 p.m. or thereafter as noted on the posted Agenda for Closed Session items in the City Council Board Room No. 5, followed by the regular meeting at 6:00 p.m. or thereafter as noted on the posted Agenda at City Hall.

Beaumont City Hall – Online www.BeaumontCa.gov

STATE ROUTE 60 TRUCK LANES

Beaumont City Council Update

May 21, 2019

Cheryl Donahue, Public Affairs Manager

Bryce Johnston, Construction Manager



Location

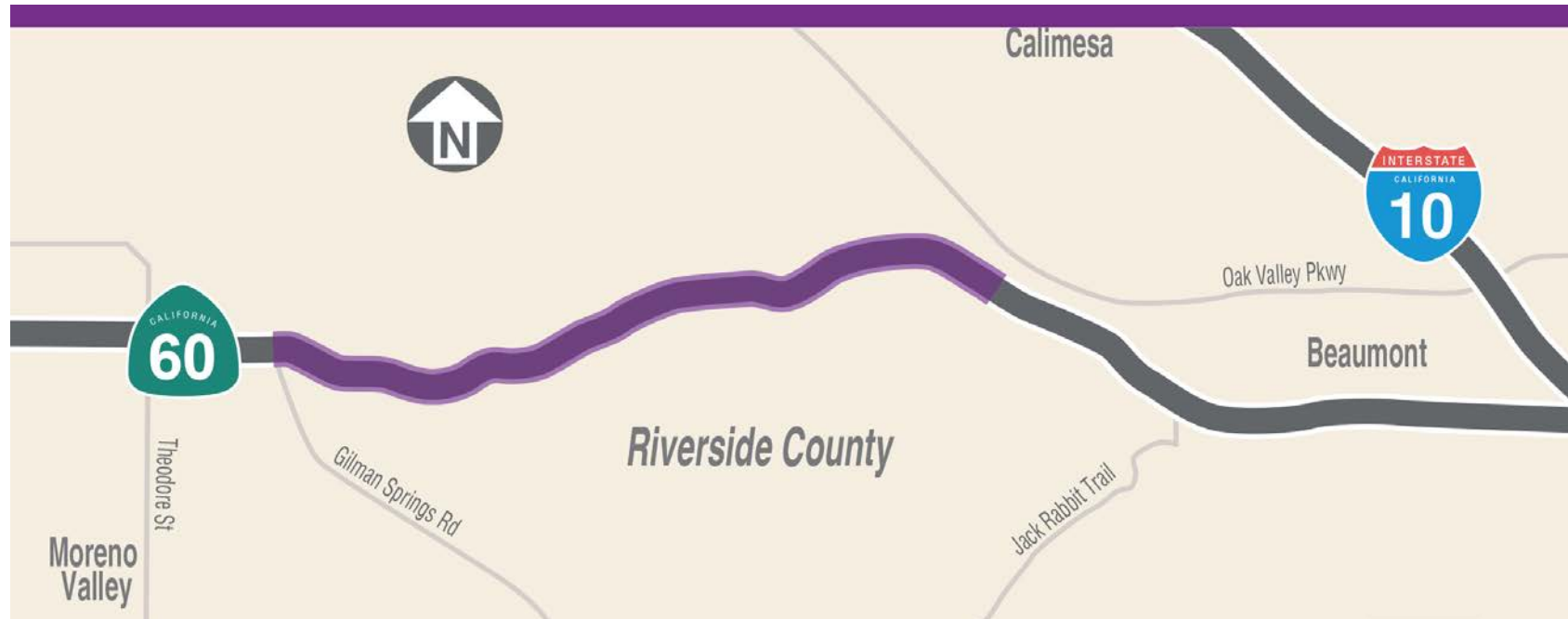

- Widen 4.5 miles of Route 60, both directions
- Gilman Springs Road to 1.4 miles west of Jack Rabbit Trail
- Unincorporated Riverside County between Moreno Valley, Beaumont

Features

- Add eastbound truck climbing lane
- Add westbound truck descending lane
- Widen shoulders to standard widths:
 - 12' outside shoulders
 - 11' inside shoulders
- Flatten roadway curves
- Increase median barrier height
- Create wildlife crossings



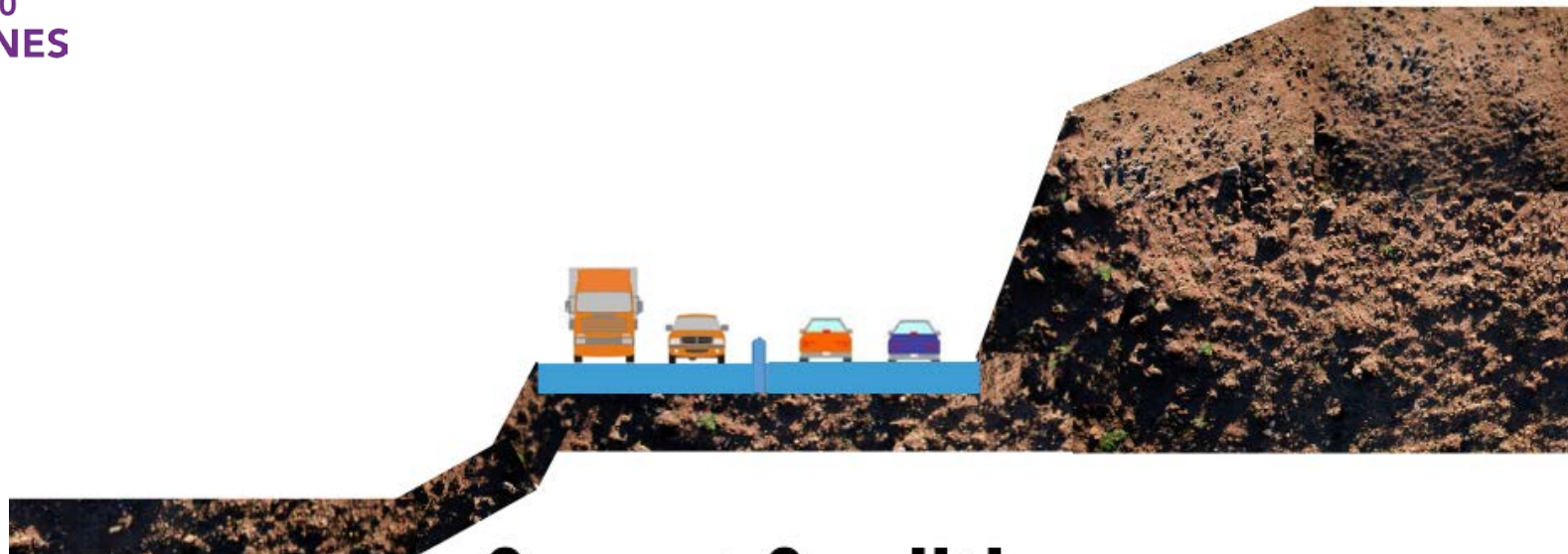

Current Condition

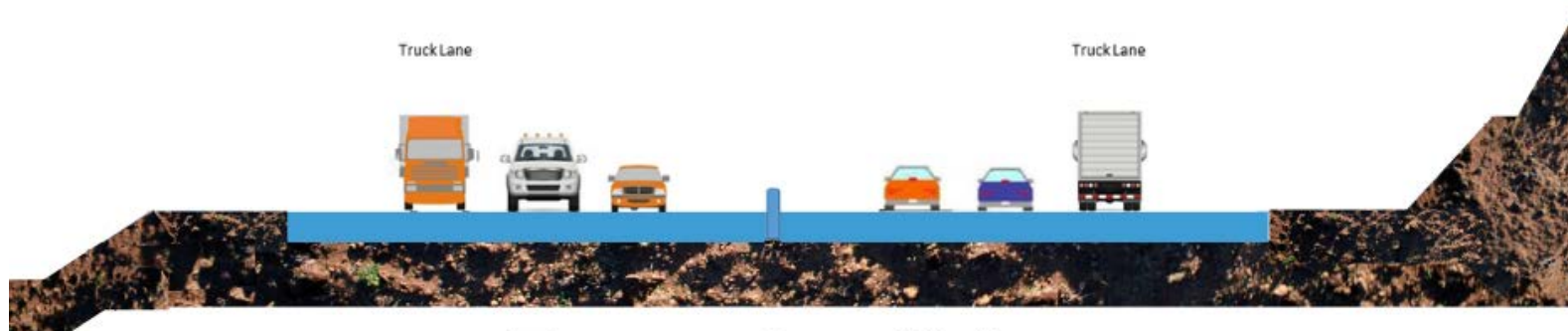

Future Condition

Purpose

- Enhance safety
- Separate trucks
- Reduce traffic congestion



Public Outreach

- Stakeholder outreach: emergency responders, tribes, trucking groups, desert resorts, businesses, HOAs
- English/Spanish communication
- Changeable message signs/billboards
- Construction updates
- Social media (@60TruckLanes) and videos
- News media, including desert stations
- Project helpline
- Open house – June 5 in Beaumont



Preliminary Schedule

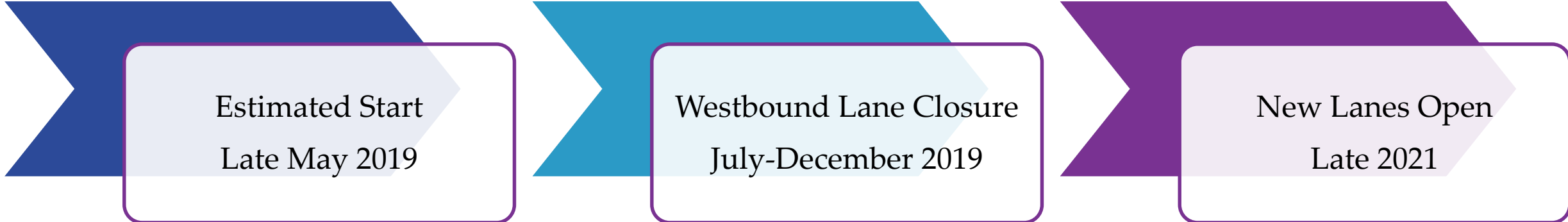

Estimated Start
Late May 2019

Westbound Lane Closure
July-December 2019

New Lanes Open
Late 2021

6-Month Lane Closure

- Close one westbound lane
 - July to December 2019
- One lane will remain open
- Will save one year of construction time
- Freeway Service Patrol will be provided
- CHP construction support
- Extensive advanced public outreach
- Note: Additional nighttime lane closures to occur during off-peak hours



Closure Area: Equipment Size/Scale



Neighboring Projects

Coordination with Caltrans, County of Riverside, corridor cities:

- I-10 Rehabilitation, Beaumont to Hwy 111
- I-10 Pavement Project, Yucaipa
- Gilman Springs Safety Corridor
- Potrero interchange, City of Beaumont



Stay Connected



rctc.org/60trucklanes



866.413.6060



60trucklanes@rctc.org



[@60trucklanes](#)



WARRANTS TO BE RATIFIED

Thursday, May 2, 2019

Printed Checks	101874-101915	\$	481,843.67	FY 18/19
EFT	157-161	\$	<u>4,744,688.69</u>	
	A/P Total	\$	<u>5,226,532.36</u>	
Voided Checks	101385	\$	45.00	Chelsie Lozano
	101458	\$	1,303.53	Diversified Distribution
	101611	\$	45,000.00	Webb Municipal Finance
	101873	\$	5,717.88	Gloria Jones

I DO HEREBY CERTIFY THIS WARRANT LIST HAS BEEN COMPILED AND PREPARED TO MEET THE DAILY OPERATIONS FOR THE FISCAL YEAR JULY 1, 2018 - JUNE 30, 2019

SIGNATURE: 
 TITLE: CITY TREASURER

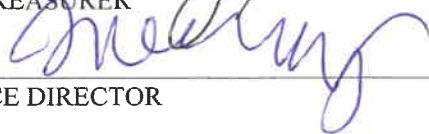
SIGNATURE: 
 TITLE: FINANCE DIRECTOR



Check Report

By Check Number

Date Range: 04/26/2019 - 05/01/2019

Vendor Number	Vendor Name	Payment Date	Payment Type	Discount Amount	Payment Amount	Number
3503	CITIZENS BUSINESS BANK	05/01/2019	EFT	0.00	182,672.25	157
Payable #	Payable Type	Post Date	Payable Description	Discount Amount	Payable Amount	
<u>APPLICATION 5</u>	Invoice	05/01/2019	W LYLES RETENTION ESCROW	0.00	182,672.25	
	<u>710-0000-8030-0000</u>		CAPITAL IMPROVEMENT W LYLES RETENTION ESCROW		182,672.25	
3229	ICMA - RC	05/01/2019	EFT	0.00	1,433.31	158
Payable #	Payable Type	Post Date	Payable Description	Discount Amount	Payable Amount	
<u>PD 4/26/19</u>	Invoice	05/01/2019	EMPLOYEE BENEFIT PPE 4/18/19	0.00	1,433.31	
	<u>100-0000-2075-0000</u>		DEFERRED COMPENSATI EMPLOYEE BENEFIT PPE 4/18/1		783.31	
	<u>100-1200-6026-0000</u>		DEFERRED COMP EMPLOYEE BENEFIT PPE 4/18/1		650.00	
3400	T.E. ROBERTS, INC	05/01/2019	EFT	0.00	628,431.61	159
Payable #	Payable Type	Post Date	Payable Description	Discount Amount	Payable Amount	
<u>APPLICATION 4</u>	Invoice	05/01/2019	Brine Line Reach 2 - Contractor	0.00	628,431.61	
	<u>710-0000-8030-0000</u>		CAPITAL IMPROVEMENT Brine Line Reach 2 - Contractor		628,431.61	
3396	W.M. LYLES CO.	05/01/2019	EFT	0.00	3,470,772.82	160
Payable #	Payable Type	Post Date	Payable Description	Discount Amount	Payable Amount	
<u>APPLICATION 5</u>	Invoice	05/01/2019	WWTP SALT MITIGATION UPGRADE - CON	0.00	3,470,772.82	
	<u>710-0000-8030-0000</u>		CAPITAL IMPROVEMENT WWTP SALT MITIGATION UPGR		3,470,772.82	
3394	WEKA INC	05/01/2019	EFT	0.00	461,378.70	161
Payable #	Payable Type	Post Date	Payable Description	Discount Amount	Payable Amount	
<u>APPLICATION 5</u>	Invoice	05/01/2019	Brine Line Reach 1 - Contractor	0.00	461,378.70	
	<u>710-0000-8030-0000</u>		CAPITAL IMPROVEMENT BRINE LINE REACH		461,378.70	
2977	GLORIA JONES	04/29/2019	Regular	0.00	5,717.88	101873
Payable #	Payable Type	Post Date	Payable Description	Discount Amount	Payable Amount	
<u>04/29/19</u>	Invoice	04/29/2019	FINAL CHECK	0.00	5,717.88	
	<u>100-0000-2105-0000</u>		PAYROLL SUSPENSE FINAL CHECK		908.52	
	<u>100-0000-2105-0000</u>		PAYROLL SUSPENSE FINAL CHECK		4,809.36	
2977	GLORIA JONES	04/29/2019	Regular	0.00	-5,717.88	101873
2977	GLORIA JONES	04/29/2019	Regular	0.00	908.52	101874
Payable #	Payable Type	Post Date	Payable Description	Discount Amount	Payable Amount	
<u>4/29/19-1</u>	Invoice	04/29/2019	FINAL CHECK HOURLY	0.00	908.52	
	<u>100-0000-2105-0000</u>		PAYROLL SUSPENSE FINAL CHECK HOURLY		908.52	
2977	GLORIA JONES	04/29/2019	Regular	0.00	4,809.36	101875
Payable #	Payable Type	Post Date	Payable Description	Discount Amount	Payable Amount	
<u>4/29/19-2</u>	Invoice	04/29/2019	FINAL CHECK BANKS	0.00	4,809.36	
	<u>100-0000-2105-0000</u>		PAYROLL SUSPENSE FINAL CHECK BANKS		4,809.36	
1042	ALL PURPOSE RENTALS	05/01/2019	Regular	0.00	95.92	101876

Check Report

Date Range: 04/26/2019 - 05/01/2019

Vendor Number	Vendor Name	Payment Date	Payment Type	Discount Amount	Payment Amount	Number
Payable #	Payable Type	Post Date	Payable Description	Discount Amount	Payable Amount	
	Account Number	Account Name	Item Description	Distribution Amount		
37465	Invoice 100-6000-7075-6040	05/01/2019	EQUIPMENT RENTAL EQUIPMENT LEASING/RE	0.00	95.92 95.92	
1125	BEAUMONT CHAMBER	05/01/2019	Regular	0.00	40.00	101877
8777	Invoice 100-1050-7035-0000 100-1200-7035-0000	05/01/2019	LOCAL MEETINGS LOCAL MEETINGS LOCAL MEETINGS	0.00	40.00 20.00 20.00	
1147	BEAUMONT CHERRY VALLEY WATER DIST.	05/01/2019	Regular	0.00	25,238.34	101878
005076-25	Invoice 100-6050-7010-008D	05/01/2019	WATER UTILITY UTILITIES IA 8D	0.00	197.43 197.43	
005076-26	Invoice 100-6050-7010-008D	05/01/2019	WATER UTILITY UTILITIES IA 8D	0.00	280.76 280.76	
020366-021	Invoice 100-6050-7010-019C	05/01/2019	WATER UTILITY UTILITIES IA 19C	0.00	25.86 25.86	
05/01/2019	Invoice 100-3250-7010-0000 100-3250-7010-007A 100-3250-7010-007B 100-3250-7010-008A 100-3250-7010-008B 100-3250-7010-010A 100-3250-7010-012A 100-3250-7010-014B 100-3250-7010-014X 100-3250-7010-015X 100-3250-7010-016X 100-3250-7010-018X 100-3250-7010-019A 100-3250-7010-019C 100-3250-7010-06A1 100-6000-7010-6025 100-6000-7010-6031 100-6000-7010-6032 100-6000-7010-6040 100-6000-7010-6045 100-6000-7010-6055 100-6050-7010-0000 100-6050-7010-003X 100-6050-7010-007A 100-6050-7010-008A 100-6050-7010-008C 100-6050-7010-008E 100-6050-7010-014A 100-6050-7010-014B 100-6050-7010-017A 100-6050-7010-018X 100-6050-7010-019C 100-6050-7010-020X 100-6050-7010-06A1 100-6050-7010-5050 100-6050-7010-5200 100-6050-7010-5250 100-6050-7010-5400	05/01/2019	WATER UTILITIES UTILITIES UTILITIES (IA 7A) UTILITIES (IA 7B) UTILITIES (IA 8A) UTILITIES (IA 8B) UTILITIES (IA 10) UTILITIES (IA 12) UTILITIES (IA 14B) UTILITIES (IA 14) UTILITIES (IA 15) UTILITIES (IA 16) UTILITIES (IA 18) UTILITIES (IA 19A) UTILITIES (IA 19C) UTILITIES (IA 6A1) UTILITIES - CITY HALL UTILITIES - CITY HALL BLD UTILITIES - CITY HALL BLD UTILITIES - POLICE DEPT UTILITIES - COMMUNITY UTILITIES - FIRE STATION UTILITIES UTILITIES IA 3 UTILITIES IA 7A UTILITIES IA 8A (SUNDAN UTILITIES IA 8C UTILITIES IA 8E UTILITIES IA 14A (OAK VA UTILITIES IA 14B UTILITIES IA 17A (TOURN UTILITIES IA 18 UTILITIES IA 19C UTILITIES IA 20 UTILITIES IA 6A1 UTILITIES, PARK (DEFORG UTILITIES, PARK (PALMER) UTILITIES, PARK (RANGAL UTILITIES, PARK (SPORTS	0.00	24,734.29 2,710.28 440.58 87.17 25.86 75.39 244.55 95.04 624.41 1,534.46 265.56 1,043.45 112.25 133.59 78.73 1,238.96 1,223.30 172.12 326.44 121.33 361.84 92.32 983.74 1,149.78 48.37 6,304.57 25.86 75.39 172.12 387.83 185.70 25.86 196.04 124.53 168.00 114.33 12.35 100.07 1,533.31	

Check Report

Date Range: 04/26/2019 - 05/01/2019

Vendor Number	Vendor Name	Payment Date	Payment Type	Discount Amount	Payment Amount	Number
	100-6050-7010-5450	UTILITIES, PARK (STETSON	WATER UTILITIES		304.04	
	100-6050-7010-5500	UTILITIES, PARK (STEWAR	WATER UTILITIES		505.53	
	100-6050-7010-5600	UTILITIES, PARK (TREVINO	WATER UTILITIES		77.33	
	100-6050-7010-5650	UTILITIES, PARK (VETERA	WATER UTILITIES		20.11	
	100-6050-7010-5700	UTILITIES, PARK (WILD FL	WATER UTILITIES		248.05	
	700-4050-7010-0000	UTILITIES	WATER UTILITIES		899.08	
	700-4050-7010-019C	UTILITIES (IA 19C)	WATER UTILITIES		16.85	
	750-7300-7010-0000	UTILITIES	WATER UTILITIES		47.82	
1127	BEAUMONT DO IT BEST HOME CENTER	05/01/2019	Regular	0.00	114.54	101879
Payable #	Payable Type	Post Date	Payable Description	Discount Amount	Payable Amount	
	Account Number		Account Name		Distribution Amount	
470989	Invoice	05/01/2019	DEPARTMENT SUPPLIES - STREETS	0.00	34.89	
	100-3250-7070-0000		SPECIAL DEPT SUPPLIES		34.89	
471316	Invoice	05/01/2019	EQUIPMENT SUPPLIES/MAINT	0.00	20.63	
	100-6000-7090-0000		EQUIPMENT SUPPLIES/M		20.63	
471317	Invoice	05/01/2019	BUILDING SUPPLIES/MAINT	0.00	17.41	
	750-7000-7085-0000		BUILDING SUPPLIES/MAI		17.41	
471318	Invoice	05/01/2019	BUILDING SUPPLIES/MAINT	0.00	34.84	
	100-6000-7085-6025		BLDG MAINT - CITY HALL		34.84	
471453	Invoice	05/01/2019	BUILDING SUPPLIES/MAINT	0.00	6.77	
	750-7000-7085-0000		BUILDING SUPPLIES/MAI		6.77	
1139	BEAUMONT POLICE OFFICERS ASSOCIATION	05/01/2019	Regular	0.00	5,150.00	101880
Payable #	Payable Type	Post Date	Payable Description	Discount Amount	Payable Amount	
	Account Number		Account Name		Distribution Amount	
PD 4/12/19-4/26	Invoice	05/01/2019	POLICE DUES	0.00	5,150.00	
	100-0000-2035-0000		C.O.P.S. DUES		5,150.00	
1250	CHAMBERS GROUP, INC	05/01/2019	Regular	0.00	2,611.80	101881
Payable #	Payable Type	Post Date	Payable Description	Discount Amount	Payable Amount	
	Account Number		Account Name		Distribution Amount	
32876	Invoice	05/01/2019	CONTRACTUAL SERVICES	0.00	2,611.80	
	700-4050-7068-0000		CONTRACTUAL SERVICES		2,611.80	
3543	CHELSIE LOZANO	05/01/2019	Regular	0.00	45.00	101882
Payable #	Payable Type	Post Date	Payable Description	Discount Amount	Payable Amount	
	Account Number		Account Name		Distribution Amount	
03/5/19	Invoice	05/01/2019	DEPOSIT REFUND	0.00	45.00	
	100-0000-4590-0000		BUILDING RENTAL		45.00	
1279	CIGNA HEALTH CARE	05/01/2019	Regular	0.00	60,968.60	101883

Check Report

Date Range: 04/26/2019 - 05/01/2019

Vendor Number	Vendor Name	Payment Date	Payment Type	Discount Amount	Payment Amount	Number
Payable #	Payable Type	Post Date	Payable Description	Discount Amount	Payable Amount	
	Account Number	Account Name	Item Description	Distribution Amount		
2462040	Invoice	05/01/2019	EMP INSURANCE	0.00	60,968.60	
	100-1200-6020-0000		HEALTH INSURANCE		2,286.86	
	100-1225-6020-0000		HEALTH INSURANCE		4,314.84	
	100-1550-6020-0000		HEALTH INSURANCE		1,725.94	
	100-2000-6020-0000		HEALTH INSURANCE		1,725.94	
	100-2030-6020-0000		HEALTH INSURANCE		1,423.90	
	100-2050-6020-0000		HEALTH INSURANCE		11,477.46	
	100-2090-6020-0000		HEALTH INSURANCE		4,012.78	
	100-3250-6020-0000		HEALTH INSURANCE		1,423.90	
	100-6050-6020-0000		HEALTH INSURANCE		8,888.56	
	700-4050-6020-0000		HEALTH INSURANCE		15,101.90	
	750-7000-6020-0000		HEALTH INSURANCE		2,847.80	
	750-7100-6020-0000		HEALTH INSURANCE		1,423.90	
	750-7200-6020-0000		HEALTH INSURANCE		2,588.90	
	750-7300-6020-0000		HEALTH INSURANCE		862.96	
	750-7400-6020-0000		HEALTH INSURANCE		862.96	
1408	DEPARTMENT OF TRANSPORTATION	05/01/2019	Regular	0.00	2,764.15	101884
Payable #	Payable Type	Post Date	Payable Description	Discount Amount	Payable Amount	
	Account Number	Account Name	Item Description	Distribution Amount		
SL190726	Invoice	05/01/2019	SIGNALS AND LIGHTING BILLING	0.00	2,764.15	
	100-3250-7010-0000		UTILITIES		2,764.15	
1424	DIRECTV	05/01/2019	Regular	0.00	137.73	101885
Payable #	Payable Type	Post Date	Payable Description	Discount Amount	Payable Amount	
	Account Number	Account Name	Item Description	Distribution Amount		
36168760325	Invoice	05/01/2019	TV UTILITY	0.00	137.73	
	100-6000-7010-6045		UTILITIES - COMMUNITY		137.73	
1479	ENTENMANN-ROVIN CO	05/01/2019	Regular	0.00	690.44	101886
Payable #	Payable Type	Post Date	Payable Description	Discount Amount	Payable Amount	
	Account Number	Account Name	Item Description	Distribution Amount		
0143239-IN	Invoice	05/01/2019	TRAVEL EDUCATION TRAINING	0.00	690.44	
	100-2050-7066-0000		TRAVEL, EDUCATION, TRA		690.44	
3347	EXECUTIVE FACILITIES SERVICES, INC	05/01/2019	Regular	0.00	8,619.51	101887
Payable #	Payable Type	Post Date	Payable Description	Discount Amount	Payable Amount	
	Account Number	Account Name	Item Description	Distribution Amount		
18644	Invoice	05/01/2019	Custodial Services	0.00	8,619.51	
	100-6000-7068-6025		CONTRACTUAL SVC - CITY		3,740.00	
	100-6000-7068-6026		CONTRACTUAL SVC - CITY		676.98	
	100-6000-7068-6028		CONTRACTUAL SVC - CITY		510.00	
	100-6000-7068-6045		CONTRACTUAL SVC - COM		2,925.00	
	100-6000-7068-6045		CONTRACTUAL SVC - COM		475.00	
	100-6000-7068-6060		CONTRACTUAL SVC- 713		167.53	
	100-6000-7068-6065		CONTRACTUAL SVC- 550		125.00	
1527	FRANCISCO VELASQUEZ	05/01/2019	Regular	0.00	4,701.29	101888
Payable #	Payable Type	Post Date	Payable Description	Discount Amount	Payable Amount	
	Account Number	Account Name	Item Description	Distribution Amount		
5/1/19	Invoice	05/01/2019	CALPERS ADVANCED DISABILITY PAYMENT	0.00	4,701.29	
	100-0000-2130-0000		P.E.R.S. LIABILITY		4,701.29	
1533	FRONTIER COMMUNICATIONS	05/01/2019	Regular	0.00	386.56	101889
Payable #	Payable Type	Post Date	Payable Description	Discount Amount	Payable Amount	
	Account Number	Account Name	Item Description	Distribution Amount		
951-769-6032-08	Invoice	05/01/2019	PHONE UTILITY	0.00	77.44	
	100-1230-7015-5400		TELEPHONE - SPORTS PAR		77.44	

Check Report

Date Range: 04/26/2019 - 05/01/2019

Vendor Number	Vendor Name	Payment Date	Payment Type	Discount Amount	Payment Amount	Number
<u>951-769-8533-09</u>	Invoice <u>750-7300-7015-0000</u>	05/01/2019	PHONE UTILITY TELEPHONE	0.00	59.95	
<u>951-769-8537-03</u>	Invoice <u>100-1230-7015-6060</u>	05/01/2019	PHONE UTILITY TELEPHONE (4th ST YARD)	0.00	69.32	
<u>951-769-8538-06</u>	Invoice <u>100-1230-7015-6048</u>	05/01/2019	PHONE UTILITY TELEPHONE (POOL)	0.00	70.98	
<u>951-922-6646-04</u>	Invoice <u>700-4050-7015-0000</u>	05/01/2019	PHONE UTILITY TELEPHONE	0.00	108.87	
1610	HDL COREN & CONE	05/01/2019	Regular	0.00	1,929.99	101890
Payable #	Payable Type	Post Date	Payable Description	Discount Amount	Payable Amount	
<u>0026517-IN</u>	Invoice <u>100-1200-7068-0000</u>	05/01/2019	CONTRACTUAL SERVICES CONTRACTUAL SERVICES	0.00	1,929.99	
3572	HECTOR ALVARADO	05/01/2019	Regular	0.00	1,000.00	101891
Payable #	Payable Type	Post Date	Payable Description	Discount Amount	Payable Amount	
<u>1035</u>	Invoice <u>750-7100-7037-0000</u> <u>750-7200-7037-0000</u> <u>750-7400-7037-0000</u> <u>750-7600-7037-0000</u>	05/01/2019	VEHICLE MAINTENANCE VEHICLE MAINTENANCE VEHICLE MAINTENANCE VEHICLE MAINTENANCE VEHICLE MAINTENANCE	0.00	1,000.00 460.00 340.00 110.00 90.00	
1622	HI-WAY SAFETY INC	05/01/2019	Regular	0.00	917.26	101892
Payable #	Payable Type	Post Date	Payable Description	Discount Amount	Payable Amount	
<u>87344</u>	Invoice <u>100-3250-7070-0000</u>	05/01/2019	STREET SUPPLIES SPECIAL DEPT SUPPLIES	0.00	917.26	
1679	INTERWEST CONSULTING GRP, INC.	05/01/2019	Regular	0.00	7,778.36	101893
Payable #	Payable Type	Post Date	Payable Description	Discount Amount	Payable Amount	
<u>47268</u>	Invoice <u>100-1200-7068-0000</u> <u>100-1350-7068-0000</u> <u>100-3100-7068-0000</u>	05/01/2019	CONTRACTUAL SERVICES CONTRACTUAL SERVICES CONTRACTUAL SERVICES CONTRACTUAL SERVICES	0.00	1,525.00 997.50 503.75 23.75	
<u>48748</u>	Invoice <u>100-2150-7063-0000</u>	05/01/2019	PLAN CHECK FEES PLAN CHECK FEES	0.00	6,253.36 6,253.36	
1773	KAISER FOUNDATION HEALTH PLAN	05/01/2019	Regular	0.00	135,681.66	101894

Check Report

Date Range: 04/26/2019 - 05/01/2019

Vendor Number	Vendor Name	Payment Date	Payment Type	Discount Amount	Payment Amount	Number
Payable #	Payable Type	Post Date	Payable Description	Discount Amount	Payable Amount	
	Account Number	Account Name	Item Description	Distribution Amount		
<u>MAY 2019</u>	Invoice	05/01/2019	HEALTH INSURANCE	0.00	135,681.66	
	100-1200-6020-0000		HEALTH INSURANCE		12,042.00	
	100-1225-6020-0000		HEALTH INSURANCE		2,980.72	
	100-1230-6020-0000		HEALTH INSURANCE		1,788.41	
	100-1240-6020-0000		HEALTH INSURANCE		1,192.31	
	100-1350-6020-0000		HEALTH INSURANCE		1,788.41	
	100-1550-6020-0000		HEALTH INSURANCE		655.77	
	100-2000-6020-0000		HEALTH INSURANCE		3,576.82	
	100-2050-6020-0000		HEALTH INSURANCE		48,048.78	
	100-2090-6020-0000		HEALTH INSURANCE		10,849.80	
	100-2150-6020-0000		HEALTH INSURANCE		6,676.77	
	100-3100-6020-0000		HEALTH INSURANCE		4,769.13	
	100-3250-6020-0000		HEALTH INSURANCE		7,153.64	
	100-6050-6020-0000		HEALTH INSURANCE		15,261.24	
	700-4050-6020-0000		HEALTH INSURANCE		2,384.57	
	750-7000-6020-0000		HEALTH INSURANCE		2,444.18	
	750-7100-6020-0000		HEALTH INSURANCE		3,099.95	
	750-7200-6020-0000		HEALTH INSURANCE		4,292.32	
	750-7300-6020-0000		HEALTH INSURANCE		5,484.52	
	750-7600-6020-0000		HEALTH INSURANCE		1,192.32	
1806	KONICA MINOLTA PREMIER FINANCE	05/01/2019	Regular	0.00	3,101.37	101895
Payable #	Payable Type	Post Date	Payable Description	Discount Amount	Payable Amount	
	Account Number	Account Name	Item Description	Distribution Amount		
<u>382380574</u>	Invoice	05/01/2019	EQUIPMENT RENTAL	0.00	3,101.37	
	100-1230-7075-0000		EQUIPMENT LEASING/RE		2,170.96	
	700-4050-7075-0000		EQUIPMENT LEASING/RE		930.41	
1895	M BREY ELECTRIC INC	05/01/2019	Regular	0.00	7,197.04	101896
Payable #	Payable Type	Post Date	Payable Description	Discount Amount	Payable Amount	
	Account Number	Account Name	Item Description	Distribution Amount		
<u>4887</u>	Invoice	05/01/2019	LIGHT POLE AT 4TH & CALIFORNIA CASE#	0.00	7,197.04	
	100-3250-8040-0000		EQUIPMENT		7,197.04	
1916	MARK THOMAS & COMPANY, INC	05/01/2019	Regular	0.00	4,794.00	101897
Payable #	Payable Type	Post Date	Payable Description	Discount Amount	Payable Amount	
	Account Number	Account Name	Item Description	Distribution Amount		
<u>33288</u>	Invoice	05/01/2019	DESIGN & CONSULTING SERVICES AMEND	0.00	4,794.00	
	500-0000-7068-0000		CONTRACTUAL SERVICE		4,794.00	
1984	NAPA AUTO PARTS	05/01/2019	Regular	0.00	29.07	101898
Payable #	Payable Type	Post Date	Payable Description	Discount Amount	Payable Amount	
	Account Number	Account Name	Item Description	Distribution Amount		
<u>088576</u>	Invoice	05/01/2019	VEHICLE MAINTENANCE	0.00	29.07	
	100-2100-7037-0000		VEHICLE MAINTENANCE		29.07	
2009	O'REILLY AUTO PARTS	05/01/2019	Regular	0.00	108.60	101899
Payable #	Payable Type	Post Date	Payable Description	Discount Amount	Payable Amount	
	Account Number	Account Name	Item Description	Distribution Amount		
<u>2678-185344</u>	Invoice	05/01/2019	VEHCILE MAINTENANCE	0.00	108.60	
	100-2100-7037-0000		VEHICLE MAINTENANCE		108.60	
3555	PLUMBERS DEPOT INC.	05/01/2019	Regular	0.00	256.57	101900
Payable #	Payable Type	Post Date	Payable Description	Discount Amount	Payable Amount	
	Account Number	Account Name	Item Description	Distribution Amount		
<u>PD-41622</u>	Invoice	05/01/2019	DEPARTMENT SUPPLIES - SEWER	0.00	256.57	
	700-4050-7070-0000		SPECIAL DEPT SUPPLIES		256.57	
2098	QUILL CORPORATON	05/01/2019	Regular	0.00	174.54	101901

Check Report

Date Range: 04/26/2019 - 05/01/2019

Vendor Number	Vendor Name	Payment Date	Payment Type	Discount Amount	Payment Amount	Number
Payable #	Payable Type	Post Date	Payable Description	Discount Amount	Payable Amount	
	Account Number	Account Name	Item Description	Distribution Amount		
6595490	Invoice	05/01/2019	OFFICE SUPPLIES	0.00	174.54	
	<u>750-7300-7025-0000</u>		OFFICE SUPPLIES		174.54	
2992	SELENT & ASSOCIATES, INC	05/01/2019	Regular	0.00	319.00	101902
Payable #	Payable Type	Post Date	Payable Description	Discount Amount	Payable Amount	
	Account Number	Account Name	Item Description	Distribution Amount		
99038210	Invoice	05/01/2019	SOFTWARE	0.00	319.00	
	<u>750-7100-7071-0000</u>		SOFTWARE		319.00	
2311	SOUTHERN CALIFORNIA EDISON	05/01/2019	Regular	0.00	12,006.89	101903
Payable #	Payable Type	Post Date	Payable Description	Discount Amount	Payable Amount	
	Account Number	Account Name	Item Description	Distribution Amount		
5/1/19	Invoice	05/01/2019	ELECTRIC UTILITY	0.00	12,006.89	
	<u>100-3250-7010-0000</u>		UTILITIES		350.42	
	<u>100-3250-7010-008A</u>		UTILITIES (IA 8A)		26.21	
	<u>100-3250-7010-014A</u>		UTILITIES (IA 14A)		100.17	
	<u>100-3250-7010-014X</u>		UTILITIES (IA 14)		39.13	
	<u>100-3250-7010-018X</u>		UTILITIES (IA 18)		56.38	
	<u>100-3250-7010-019C</u>		UTILITIES (IA 19C)		12.49	
	<u>100-3250-7010-06A1</u>		UTILITIES (IA 6A1)		47.60	
	<u>100-6000-7010-6025</u>		UTILITIES - CITY HALL		1,376.46	
	<u>100-6000-7010-6031</u>		UTILITIES - CITY HALL BLD		839.49	
	<u>100-6000-7010-6032</u>		UTILITIES - CITY HALL BLD		839.49	
	<u>100-6000-7010-6040</u>		UTILITIES - POLICE DEPT		2,057.31	
	<u>100-6000-7010-6055</u>		UTILITIES - FIRE STATION		317.33	
	<u>100-6050-7010-0000</u>		UTILITIES		1,754.17	
	<u>100-6050-7010-002X</u>		UTILITIES IA 2		155.82	
	<u>100-6050-7010-005X</u>		UTILITIES IA 5		3,391.19	
	<u>100-6050-7010-007A</u>		UTILITIES IA 7A		14.08	
	<u>100-6050-7010-008C</u>		UTILITIES IA 8C		13.27	
	<u>100-6050-7010-008E</u>		UTILITIES IA 8E		12.71	
	<u>100-6050-7010-014X</u>		UTILITIES IA 14		11.74	
	<u>100-6050-7010-06A1</u>		UTILITIES IA 6A1		58.83	
	<u>100-6050-7010-5400</u>		UTILITIES, PARK (SPORTS		471.87	
	<u>100-6050-7010-5500</u>		UTILITIES, PARK (STEWAR		60.73	
3246	STURGEON ELECTRIC CALIFORNIA, LLC	05/01/2019	Regular	0.00	93,600.00	101904
Payable #	Payable Type	Post Date	Payable Description	Discount Amount	Payable Amount	
	Account Number	Account Name	Item Description	Distribution Amount		
545485	Invoice	05/01/2019	I-10/OAK VALLEY PARKWAY TRAFFIC SIGN	0.00	93,600.00	
	<u>500-0000-8030-0000</u>		INFRASTRUCTURE IMPRO		62,796.27	
	<u>500-0000-8030-0000</u>		INFRASTRUCTURE IMPRO		30,803.73	
2399	TETRA TECH INC	05/01/2019	Regular	0.00	5,291.30	101905
Payable #	Payable Type	Post Date	Payable Description	Discount Amount	Payable Amount	
	Account Number	Account Name	Item Description	Distribution Amount		
51432957	Invoice	05/01/2019	DESIGN & GEOTECH FOR SENECA SPRING	0.00	5,291.30	
	<u>710-0000-7068-0000</u>		CONTRACTUAL SERVICE		5,291.30	
2407	THE GAS COMPANY	05/01/2019	Regular	0.00	1,075.12	101906
Payable #	Payable Type	Post Date	Payable Description	Discount Amount	Payable Amount	
	Account Number	Account Name	Item Description	Distribution Amount		
09712228007 5/1	Invoice	05/01/2019	GAS UTILITY	0.00	763.93	
	<u>100-6000-7010-6025</u>		UTILITIES - CITY HALL		763.93	
13912227587 5/1	Invoice	05/01/2019	GAS UTILITY	0.00	119.62	
	<u>750-7000-7010-0000</u>		UTILITIES		119.62	
15382227021 5/1	Invoice	05/01/2019	GAS UTILITY	0.00	191.57	

Check Report

Date Range: 04/26/2019 - 05/01/2019

Vendor Number	Vendor Name	Payment Date	Payment Type	Discount Amount	Payment Amount	Number
	750-7000-7010-0000	UTILITIES	GAS UTILITY		191.57	
2430	TIME WARNER CABLE	05/01/2019	Regular	0.00	1,982.45	101907
Payable #	Payable Type	Post Date	Payable Description	Discount Amount	Payable Amount	
	Account Number		Account Name	Item Description	Distribution Amount	
0013594041019	Invoice	05/01/2019	PHONE UTILITY	0.00	127.95	
	100-1230-7015-6040		TELEPHONE (POLICE DPT)		127.95	
0014188041019	Invoice	05/01/2019	PHONE UTILITY	0.00	45.35	
	100-1230-7015-6055		TELEPHONE (MAPLE AVE)		45.35	
0241971041519	Invoice	05/01/2019	PHONE UTILITY	0.00	1,809.15	
	100-1230-7015-6025		TELEPHONE (CITY HALL)		1,809.15	
2889	TRANSTECH ENGINEERS, INC	05/01/2019	Regular	0.00	4,320.00	101908
Payable #	Payable Type	Post Date	Payable Description	Discount Amount	Payable Amount	
	Account Number		Account Name	Item Description	Distribution Amount	
20191270	Invoice	05/01/2019	PROFESSIONAL ENG SERVICES FOR POTRE	0.00	4,320.00	
	500-0000-7068-0000		CONTRACTUAL SERVICE		4,320.00	
3604	TREETOP PRODUCTS, INC	05/01/2019	Regular	0.00	10,161.05	101909
Payable #	Payable Type	Post Date	Payable Description	Discount Amount	Payable Amount	
	Account Number		Account Name	Item Description	Distribution Amount	
KB00009239	Invoice	05/01/2019	PLUNGE FURNITURE	0.00	10,161.05	
	500-0000-8014-0000		BUILDING IMPROVEMEN		10,161.05	
2461	UNDERGROUND SERVICE ALERT	05/01/2019	Regular	0.00	270.80	101910
Payable #	Payable Type	Post Date	Payable Description	Discount Amount	Payable Amount	
	Account Number		Account Name	Item Description	Distribution Amount	
120190045	Invoice	05/01/2019	DIG ALERT - SEWER	0.00	161.80	
	700-4050-7068-0000		CONTRACTUAL SERVICES		161.80	
1220180045	Invoice	05/01/2019	DIG ALERT - SEWER	0.00	109.00	
	700-4050-7068-0000		CONTRACTUAL SERVICES		109.00	
2462	UNIFIRST CORPORATION	05/01/2019	Regular	0.00	1,724.14	101911
Payable #	Payable Type	Post Date	Payable Description	Discount Amount	Payable Amount	
	Account Number		Account Name	Item Description	Distribution Amount	
325 1376427	Invoice	05/01/2019	UNIFORMS	0.00	426.76	
	100-3250-7065-0000		UNIFORMS		57.60	
	700-4050-7065-0000		UNIFORMS		25.90	
	750-7000-7065-0000		UNIFORMS		256.26	
	750-7400-7065-0000		UNIFORMS		43.50	
	750-7600-7065-0000		UNIFORMS		43.50	
325 1402240	Invoice	05/01/2019	UNIFORMS	0.00	435.06	
	100-3250-7065-0000		UNIFORMS		57.60	
	700-4050-7065-0000		UNIFORMS		53.18	
	750-7200-7065-0000		UNIFORMS		237.28	
	750-7400-7065-0000		UNIFORMS		43.50	
	750-7600-7065-0000		UNIFORMS		43.50	
325 1404776	Invoice	05/01/2019	UNIFORMS	0.00	431.16	
	100-3250-7065-0000		UNIFORMS		57.60	
	700-4050-7065-0000		UNIFORMS		53.18	
	750-7200-7065-0000		UNIFORMS		233.38	
	750-7400-7065-0000		UNIFORMS		43.50	
	750-7600-7065-0000		UNIFORMS		43.50	
325-1407297	Invoice	05/01/2019	UNIFORMS	0.00	431.16	
	100-3250-7065-0000		UNIFORMS		57.60	
	700-4050-7065-0000		UNIFORMS		53.18	
	750-7000-7065-0000		UNIFORMS		233.38	
	750-7400-7065-0000		UNIFORMS		43.50	

Check Report

Date Range: 04/26/2019 - 05/01/2019

Vendor Number	Vendor Name	Payment Date	Payment Type	Discount Amount	Payment Amount	Number
	750-7600-7065-0000	UNIFORMS	UNIFORMS		43.50	
2515	VIVINT SOLAR DEVELOPMENT, LLC	05/01/2019	Regular	0.00	168.80	101912
Payable #	Payable Type	Post Date	Payable Description	Discount Amount	Payable Amount	
BLDR2018-3884	Invoice	05/01/2019	REFUND PERMIT FEES	0.00	168.80	
	100-0000-4310-0000		BUILDING PERMITS AND I		168.80	
			REFUND PERMIT FEES			
2517	VOYAGER	05/01/2019	Regular	0.00	48,160.24	101913
Payable #	Payable Type	Post Date	Payable Description	Discount Amount	Payable Amount	
869065003917	Invoice	05/01/2019	GAS CARDS	0.00	48,160.24	
	100-1550-7050-0000		FUEL		626.78	
	100-2000-7050-0000		FUEL		781.25	
	100-2030-7050-0000		FUEL		126.46	
	100-2050-7050-0000		FUEL		14,092.97	
	100-2100-7050-0000		FUEL		199.71	
	100-2150-7050-0000		FUEL		530.77	
	100-3250-7050-0000		FUEL		1,987.94	
	100-6050-7050-0000		FUEL		4,748.23	
	700-4050-7050-0000		FUEL		1,447.95	
	750-7000-7050-0000		FUEL		28.73	
	750-7100-7050-0000		FUEL		1,938.87	
	750-7200-7050-0000		FUEL		13,339.70	
	750-7300-7050-0000		FUEL		293.15	
	750-7400-7050-0000		FUEL		6,370.26	
	750-7600-7050-0000		FUEL		1,647.47	
3248	WEBB MUNICIPAL FINANCE, LLC	05/01/2019	Regular	0.00	26,500.00	101914
Payable #	Payable Type	Post Date	Payable Description	Discount Amount	Payable Amount	
20190130-2	Invoice	05/01/2019	CONTRACTUAL SERVICES	0.00	25,000.00	
	250-0000-1139-0000		CFD FORMATION - PARDE		25,000.00	
20190138	Invoice	05/01/2019	CONTRACTUAL SERVICES	0.00	500.00	
	250-0000-7068-0000		CONTRACTUAL SERVICES		500.00	
20190176	Invoice	05/01/2019	CONTRACTUAL SERVICES	0.00	500.00	
	250-0000-7068-0000		CONTRACTUAL SERVICES		500.00	
20190177	Invoice	05/01/2019	CONTRACTUAL SERVICES	0.00	500.00	
	250-0000-7068-0000		CONTRACTUAL SERVICES		500.00	
3457	ZONAR SYSTEMS	05/01/2019	Regular	0.00	1,731.54	101915
Payable #	Payable Type	Post Date	Payable Description	Discount Amount	Payable Amount	
SI402383	Invoice	05/01/2019	CONTRACTUAL SERVICES	0.00	1,731.54	
	760-0000-7068-0000		CONTRACTUAL SERVICE		1,731.54	

Bank Code APBNK Summary

Payment Type	Payable Count	Payment Count	Discount	Payment
Regular Checks	66	43	0.00	493,279.43
Manual Checks	0	0	0.00	0.00
Voided Checks	0	1	0.00	-5,717.88
Bank Drafts	0	0	0.00	0.00
EFT's	5	5	0.00	4,744,688.69
	71	49	0.00	5,232,250.24

All Bank Codes Check Summary

Payment Type	Payable Count	Payment Count	Discount	Payment
Regular Checks	66	43	0.00	493,279.43
Manual Checks	0	0	0.00	0.00
Voided Checks	0	1	0.00	-5,717.88
Bank Drafts	0	0	0.00	0.00
EFT's	5	5	0.00	4,744,688.69
	71	49	0.00	5,232,250.24

Fund Summary

Fund	Name	Period	Amount
999	POOLED CASH	4/2019	5,717.88
999	POOLED CASH	5/2019	5,226,532.36
			5,232,250.24



WARRANTS TO BE RATIFIED

Thursday, May 09, 2019

Printed Checks	101916-102000	\$	461,531.45	FY 18/19
EFT	162-164	\$	56,098.60	
Bank Drafts	Guardian	\$	21,103.66	19-May
	CalPERS	\$	64,088.44	743 Classic Unfunded Liability
		\$	30,010.10	742 Classic Unfunded Liability
		\$	172.77	27308 PEPRA Unfunded Liability
		\$	85.49	25763 PEPRA Unfunded Liability
	A/P Total	<u>\$</u>	<u>633,090.51</u>	
Wire	5/7/2019	\$	6,240.48	Account transfer for April 2019 credit card usage
Voided Checks	101829	\$	82.36	Julio Martinez
Bank Drafts	Affant	\$	548.00	May-19
	Gateway	\$	335.85	CC Fees

I DO HEREBY CERTIFY THIS WARRANT LIST HAS BEEN COMPILED AND PREPARED TO MEET THE DAILY OPERATIONS FOR THE FISCAL YEAR JULY 1, 2018 - JUNE 30, 2019

SIGNATURE: *Baron J. Linneth*
 TITLE: CITY TREASURER

SIGNATURE: *[Signature]*
 TITLE: FINANCE DIRECTOR



Vendor Number	Vendor Name	Payment Date	Payment Type	Discount Amount	Payment Amount	Number
2264	SEIU	05/09/2019	EFT	0.00	1,433.57	162
Payable #	Payable Type	Post Date	Payable Description	Discount Amount	Payable Amount	
<u>PD 03/01/19-03/</u>	Invoice	05/08/2019	EMPLOYEE DUES	0.00	1,433.57	
	<u>100-0000-2061-0000</u>		P.E.R.C. DUES & INS		1,433.57	
2264	SEIU	05/09/2019	EFT	0.00	1,427.03	163
Payable #	Payable Type	Post Date	Payable Description	Discount Amount	Payable Amount	
<u>PD 04/26/19</u>	Invoice	05/08/2019	EMPLOYEE DUES	0.00	1,427.03	
	<u>100-0000-2061-0000</u>		P.E.R.C. DUES & INS		1,427.03	
3101	WRCOG	05/09/2019	EFT	0.00	53,238.00	164
Payable #	Payable Type	Post Date	Payable Description	Discount Amount	Payable Amount	
<u>APR 2019</u>	Invoice	05/08/2019	APRIL 2019 TUMF FEES	0.00	53,238.00	
	<u>570-0000-2010-0000</u>		DUE TO WRCOG (TUMF)		53,238.00	
1023	ADVANCED WORKPLACE STRATEGIES	05/09/2019	Regular	0.00	198.00	101916
Payable #	Payable Type	Post Date	Payable Description	Discount Amount	Payable Amount	
<u>399836</u>	Invoice	05/08/2019	EMPLOYEE MEDICAL SERVICES	0.00	66.00	
	<u>100-3250-6019-0000</u>		FIRST AID		66.00	
<u>400994</u>	Invoice	05/08/2019	EMPLOYEE MEDICAL SERVICES	0.00	132.00	
	<u>100-6050-6019-0000</u>		FIRST AID		66.00	
	<u>750-7200-6019-0000</u>		FIRST AID		66.00	
1042	ALL PURPOSE RENTALS	05/09/2019	Regular	0.00	514.37	101917
Payable #	Payable Type	Post Date	Payable Description	Discount Amount	Payable Amount	
<u>37300</u>	Invoice	05/08/2019	EQUIPMENT RENTAL - SEWER	0.00	514.37	
	<u>700-4050-7075-0000</u>		EQUIPMENT LEASING/RE		514.37	
1050	AMAZON CAPITAL SERVICES	05/09/2019	Regular	0.00	897.67	101918
Payable #	Payable Type	Post Date	Payable Description	Discount Amount	Payable Amount	
<u>13KC-THGC-4NLQ</u>	Invoice	05/08/2019	OFFICE SUPPLIES	0.00	57.99	
	<u>100-1200-7025-0000</u>		OFFICE SUPPLIES		57.99	
<u>1CD4-679F-H9RF</u>	Invoice	05/08/2019	OFFICE SUPPLIES	0.00	243.95	
	<u>100-2050-7025-0000</u>		OFFICE SUPPLIES		243.95	
<u>1JCX-6FXJ-WY93</u>	Invoice	05/08/2019	OFFICE SUPPLIES	0.00	223.85	
	<u>100-2050-7025-0000</u>		OFFICE SUPPLIES		223.85	
<u>1JWG-X4LK-DGCF</u>	Invoice	05/08/2019	OFFICE SUPPLIES	0.00	371.88	
	<u>100-2050-7025-0000</u>		OFFICE SUPPLIES		371.88	
1053	AMERICAN FORENSIC NURSES	05/09/2019	Regular	0.00	48.00	101919
Payable #	Payable Type	Post Date	Payable Description	Discount Amount	Payable Amount	
<u>72057</u>	Invoice	05/08/2019	American Forensic Nurses - Blood Analy	0.00	48.00	
	<u>100-2050-7068-0000</u>		CONTRACTUAL SERVICES		48.00	
3619	AMERICAN LEAK DETECTION	05/09/2019	Regular	0.00	500.00	101920

Check Report

Date Range: 05/02/2019 - 05/09/2019

Vendor Number	Vendor Name	Payment Date	Payment Type	Discount Amount	Payment Amount	Number
Payable #	Payable Type	Post Date	Payable Description	Discount Amount	Payable Amount	
	Account Number	Account Name	Item Description	Distribution Amount		
<u>69150584</u>	Invoice <u>100-6150-7068-0000</u>	05/08/2019	PROFESSIONAL SERVICES CONTRACTUAL SERVICES	0.00	500.00	
1100	AUTOZONE	05/09/2019	Regular	0.00	4.51	101921
<u>2882877567</u>	Invoice <u>100-2050-7037-0000</u>	05/08/2019	VEHICLE MAINTENANCE VEHICLE MAINTENANCE	0.00	4.51	
2852	BADGE FRAME, INC.	05/09/2019	Regular	0.00	1,772.49	101922
<u>34223</u>	Invoice <u>100-2050-7090-0000</u>	05/08/2019	EQUIPMENT SUPPLIES EQUIPMENT SUPPLIES/M	0.00	1,772.49	
1147	BEAUMONT CHERRY VALLEY WATER DIST.	05/09/2019	Regular	0.00	110.00	101923
<u>046156-001 06/0</u>	Invoice <u>700-4050-7010-0000</u>	05/08/2019	WATER UTILITIES UTILITIES	0.00	110.00	
1127	BEAUMONT DO IT BEST HOME CENTER	05/09/2019	Regular	0.00	3.87	101924
<u>469733</u>	Invoice <u>100-2050-7037-0000</u>	05/08/2019	VEHICLE MAINTENANCE VEHICLE MAINTENANCE	0.00	3.87	
1136	BEAUMONT POWER EQUIPMENT	05/09/2019	Regular	0.00	97.46	101925
<u>11</u>	Invoice <u>100-6050-7090-5999</u>	05/08/2019	DEPT SUPPLIES EQUIP SUPPLIES/MAINT -	0.00	97.46	
1149	BEHAVIORAL ANALYSIS TRAINING INSTITUTE	05/09/2019	Regular	0.00	481.00	101926
<u>IV01911</u>	Invoice <u>100-2050-7066-0000</u>	05/08/2019	EMPLOYEE TRAINING TRAVEL, EDUCATION, TRA	0.00	481.00	
1161	BIO-TOX LABORATORIES	05/09/2019	Regular	0.00	492.00	101927
<u>37839</u>	Invoice <u>100-2050-7068-0000</u>	05/08/2019	BioTox Blood Analysis CONTRACTUAL SERVICES	0.00	381.00	
<u>37952</u>	Invoice <u>100-2050-7068-0000</u>	05/08/2019	BioTox Blood Analysis CONTRACTUAL SERVICES	0.00	111.00	
2861	BROWNELLS, INC	05/09/2019	Regular	0.00	99.99	101928
<u>04/30/19</u>	Invoice <u>100-2050-7070-0000</u>	05/08/2019	DEPT SUPPLIES SPECIAL DEPT SUPPLIES	0.00	99.99	
3460	CALIFORNIA POLICE CHEIFS ASSOCIATION	05/09/2019	Regular	0.00	695.00	101929

Check Report

Date Range: 05/02/2019 - 05/09/2019

Vendor Number	Vendor Name	Payment Date	Payment Type	Discount Amount	Payment Amount	Number
Payable #	Payable Type	Post Date	Payable Description	Discount Amount	Payable Amount	
	Account Number	Account Name	Item Description	Distribution Amount		
<u>12811</u>	Invoice 100-2050-7030-0000	05/08/2019	MEMBERSHIP RENEWAL DUES & SUBSCRIPTIONS	0.00	695.00 695.00	
3614	CAROL FRANCIS	05/09/2019	Regular	0.00	1,367.67	101930
<u>RCT 891770</u>	Invoice 100-0000-4556-0000	05/08/2019	REFUND OF FUNDS NOT USED FOR PP201 PLANNING DEPARTMENT	0.00	1,367.67 1,367.67	
3311	CARPET STATION TILE & WOOD, INC	05/09/2019	Regular	0.00	2,895.00	101931
<u>16102</u>	Invoice 225-0000-8040-0000	05/08/2019	BUILDING MAINTENANCE EQUIPMENT	0.00	2,895.00 2,895.00	
1238	CDW GOVERNMENT, INC.	05/09/2019	Regular	0.00	4,290.95	101932
<u>RXZ1384</u>	Invoice 220-0000-7072-0000	05/08/2019	COMPUTER SUPPLIES COMPUTER SUPPLIES/MA	0.00	4,290.95 4,290.95	
1305	CNOA	05/09/2019	Regular	0.00	180.00	101933
<u>000011</u>	Invoice 100-2050-7066-0000	05/08/2019	EMPLOYEE EDUCATION TRAVEL, EDUCATION, TRA	0.00	180.00 180.00	
1307	COLE VOCATIONAL	05/09/2019	Regular	0.00	1,176.00	101934
<u>043019</u>	Invoice 100-2050-7085-0000	05/08/2019	BUILDING MAINTENANCE BUILDING SUPPLIES/MAI	0.00	1,176.00 1,176.00	
1340	CPS HR CONSULTING	05/09/2019	Regular	0.00	199.00	101935
<u>91153</u>	Invoice 100-1240-7066-0000	05/08/2019	EMPLOYEE EDUCATION TRAVEL, EDUCATION, TRA	0.00	199.00 199.00	
1424	DIRECTV	05/09/2019	Regular	0.00	108.99	101936
<u>36180431471</u>	Invoice 100-6000-7010-6040	05/08/2019	UTILITY UTILITIES - POLICE DEPT	0.00	108.99 108.99	
2846	DIVERSIFIED DISTRIBUTION	05/09/2019	Regular	0.00	1,303.54	101937
<u>116057 CHECK 2</u>	Invoice 750-7200-7070-0000	05/08/2019	DEPT SUPPLIES SPECIAL DEPT SUPPLIES	0.00	1,303.54 1,303.54	
3620	DKC ARCHITECTS	05/09/2019	Regular	0.00	831.23	101938
<u>RCT 878006</u>	Invoice 100-0000-2500-0000	05/08/2019	DEPOSIT REFUND PP2018-0165 HELD ON DEPOSIT-PLANN	0.00	831.23 831.23	
3615	DUSTIN GUTIERREZ	05/09/2019	Regular	0.00	6.36	101939

Check Report

Date Range: 05/02/2019 - 05/09/2019

Vendor Number	Vendor Name	Payment Date	Payment Type	Discount Amount	Payment Amount	Number
Payable #	Payable Type	Post Date	Payable Description	Discount Amount	Payable Amount	
	Account Number	Account Name	Item Description	Distribution Amount		
04-011242-03	Invoice 100-0000-1400-0000	05/08/2019	REIMBURSE CREDIT ON FINALED UTILITY A/R - UTILITIES	0.00	6.36	
1501	FAIRVIEW FORD	05/09/2019	Regular	0.00	378.35	101940
568105	Invoice 100-2050-7037-0000	05/08/2019	VEHICLE MAINTENANCE VEHICLE MAINTENANCE	0.00	38.98	
568307	Invoice 100-2050-7037-0000	05/08/2019	VEHICLE MAINTENANCE VEHICLE MAINTENANCE	0.00	77.95	
568922	Invoice 100-2050-7037-0000	05/08/2019	VEHICLE MAINTENANCE VEHICLE MAINTENANCE	0.00	109.27	
591897	Invoice 100-2050-7037-0000	05/08/2019	VEHICLE MAINTENANCE VEHICLE MAINTENANCE	0.00	80.40	
592640	Invoice 100-2050-7037-0000	05/08/2019	VEHICLE MAINTENANCE VEHICLE MAINTENANCE	0.00	53.22	
593255	Invoice 100-2050-7037-0000	05/08/2019	VEHICLE MAINTENANCE VEHICLE MAINTENANCE	0.00	18.53	
1509	FEDEX	05/09/2019	Regular	0.00	40.78	101941
6-541-59124	Invoice 100-1240-7025-0000	05/08/2019	OFFICE SUPPLY - SHIPPING OFFICE SUPPLIES	0.00	40.78	
1518	FLYERS ENERGY	05/09/2019	Regular	0.00	606.18	101942
19-883123	Invoice 100-2050-7037-0000	05/08/2019	VEHICLE MAINTENANCE VEHICLE MAINTENANCE	0.00	606.18	
1522	FOX OCCUPATIONAL	05/09/2019	Regular	0.00	105.00	101943
105796	Invoice 100-1240-6050-0000	05/08/2019	HIRING COSTS RECRUITMENT AND HIRI	0.00	105.00	
1533	FRONTIER COMMUNICATIONS	05/09/2019	Regular	0.00	2,841.61	101944
213-181-1343-03	Invoice 700-4050-7015-0000	05/08/2019	PHONE UTILITY TELEPHONE	0.00	250.03	
323-156-8188-02	Invoice 100-1230-7015-6060	05/08/2019	PHONE UTILITY TELEPHONE (4th ST YARD)	0.00	85.98	
951-769-8500-01	Invoice 100-1230-7015-6040	05/08/2019	PHONE UTILITY TELEPHONE (POLICE DPT)	0.00	1,849.02	
951-769-8520-01	Invoice 100-1230-7015-6025	05/08/2019	PHONE UTILITY TELEPHONE (CITY HALL)	0.00	263.97	
951-769-8530-06	Invoice 750-7000-7015-0000	05/08/2019	PHONE UTILITY TELEPHONE	0.00	254.56	
951-769-8539-04	Invoice 100-1230-7015-6045	05/08/2019	PHONE UTILITY TELEPHONE (COMM CTR)	0.00	138.05	
1550	G&G ENVIRONMENTAL COMPLIANCE, INC	05/09/2019	Regular	0.00	8,823.90	101945

Check Report

Date Range: 05/02/2019 - 05/09/2019

Vendor Number	Vendor Name	Payment Date	Payment Type	Discount Amount	Payment Amount	Number
Payable #	Payable Type	Post Date	Payable Description	Discount Amount	Payable Amount	
	Account Number	Account Name	Item Description	Distribution Amount		
BEAUMONT-0419	Invoice	05/08/2019	WASTEWATER REGULATORY PROGRAM	0.00	8,823.90	
	700-4050-7068-0000		CONTRACTUAL SERVICES		8,823.90	
1554	GALLADE CHEMICAL, INC.	05/09/2019	Regular	0.00	1,104.44	101946
Payable #	Payable Type	Post Date	Payable Description	Discount Amount	Payable Amount	
	Account Number	Account Name	Item Description	Distribution Amount		
1067574	Invoice	05/08/2019	CHEMICALS FOR WWTP	0.00	1,104.44	
	700-4050-7070-0000		SPECIAL DEPT SUPPLIES		1,104.44	
1553	GALLS INC.	05/09/2019	Regular	0.00	724.26	101947
Payable #	Payable Type	Post Date	Payable Description	Discount Amount	Payable Amount	
	Account Number	Account Name	Item Description	Distribution Amount		
BC0830122	Invoice	05/08/2019	EMPLOYEE UNIFORM	0.00	724.26	
	100-2050-7065-0000		UNIFORMS		724.26	
3042	GOLDEN STAR TECHNOLOGY, INC	05/09/2019	Regular	0.00	12,827.50	101948
Payable #	Payable Type	Post Date	Payable Description	Discount Amount	Payable Amount	
	Account Number	Account Name	Item Description	Distribution Amount		
INV33341	Invoice	05/08/2019	IT SERVICES	0.00	12,827.50	
	100-1230-7068-0000		CONTRACTUAL SERVICES		12,827.50	
3524	H&T CULTURAL RESOURCE MANAGEMENT, INC	05/09/2019	Regular	0.00	3,782.50	101949
Payable #	Payable Type	Post Date	Payable Description	Discount Amount	Payable Amount	
	Account Number	Account Name	Item Description	Distribution Amount		
REV. 4739	Invoice	05/08/2019	archaeologist for WWTP expansion	0.00	3,782.50	
	710-0000-7068-0000		CONTRACTUAL SERVICE		3,782.50	
1603	HACH COMPANY	05/09/2019	Regular	0.00	3,301.62	101950
Payable #	Payable Type	Post Date	Payable Description	Discount Amount	Payable Amount	
	Account Number	Account Name	Item Description	Distribution Amount		
11433253	Invoice	05/08/2019	WWTP EQUIPMENT	0.00	3,146.46	
	700-4050-7070-0000		SPECIAL DEPT SUPPLIES		3,146.46	
11437648	Invoice	05/08/2019	WWTP EQUIPMENT	0.00	155.16	
	700-4050-7070-0000		SPECIAL DEPT SUPPLIES		155.16	
1643	HUNTINGTON COURT REPORTERS & TRANSCRI	05/09/2019	Regular	0.00	975.30	101951
Payable #	Payable Type	Post Date	Payable Description	Discount Amount	Payable Amount	
	Account Number	Account Name	Item Description	Distribution Amount		
31891	Invoice	05/08/2019	Huntington Transcription Services	0.00	975.30	
	100-2050-7068-0000		CONTRACTUAL SERVICES		975.30	
3516	INLAND WATER WORKS SUPPLY CO	05/09/2019	Regular	0.00	2,876.93	101952
Payable #	Payable Type	Post Date	Payable Description	Discount Amount	Payable Amount	
	Account Number	Account Name	Item Description	Distribution Amount		
S1022284.001	Invoice	05/08/2019	DEPARTMENT SUPPLIES - SEWER	0.00	2,876.93	
	700-4050-7070-0000		SPECIAL DEPT SUPPLIES		2,876.93	
1679	INTERWEST CONSULTING GRP, INC.	05/09/2019	Regular	0.00	2,970.00	101953
Payable #	Payable Type	Post Date	Payable Description	Discount Amount	Payable Amount	
	Account Number	Account Name	Item Description	Distribution Amount		
48982	Invoice	05/08/2019	GIS SERVICES FOR FY 18/19	0.00	2,970.00	
	100-1230-7071-0000		SOFTWARE		262.50	
	100-3100-7068-0000		CONTRACTUAL SERVICES		2,232.50	
	220-0000-7068-0000		CONTRACTUAL SERVICES		475.00	
2527	JESUS CAMACHO	05/09/2019	Regular	0.00	95.00	101954

Check Report

Date Range: 05/02/2019 - 05/09/2019

Vendor Number	Vendor Name	Payment Date	Payment Type	Discount Amount	Payment Amount	Number
Payable #	Payable Type	Post Date	Payable Description	Discount Amount	Payable Amount	
	Account Number	Account Name	Item Description	Distribution Amount		
<u>151124</u>	Invoice	05/08/2019	Car Wash	0.00	95.00	
	<u>100-2150-7037-0000</u>		VEHICLE MAINTENANCE		95.00	
2908	JULIO MARTINEZ	05/09/2019	Regular	0.00	82.36	101955
Payable #	Payable Type	Post Date	Payable Description	Discount Amount	Payable Amount	
	Account Number	Account Name	Item Description	Distribution Amount		
<u>03/28/19 CHECK</u>	Invoice	05/08/2019	REIMBURSEMENT FOR MILEAGE	0.00	82.36	
	<u>100-1050-7035-0000</u>		LOCAL MEETINGS		82.36	
1788	KEN GRIMES	05/09/2019	Regular	0.00	315.00	101956
Payable #	Payable Type	Post Date	Payable Description	Discount Amount	Payable Amount	
	Account Number	Account Name	Item Description	Distribution Amount		
<u>07/22/19-07/26/</u>	Invoice	05/08/2019	EMPLOYEE EDUCATION	0.00	315.00	
	<u>100-2050-7066-0000</u>		TRAVEL, EDUCATION, TRA		315.00	
1805	KONICA MINOLTA BUSINESS SOLUTIONS	05/09/2019	Regular	0.00	123.92	101957
Payable #	Payable Type	Post Date	Payable Description	Discount Amount	Payable Amount	
	Account Number	Account Name	Item Description	Distribution Amount		
<u>33395841</u>	Invoice	05/08/2019	EQUIPMENT MAINTENANCE	0.00	123.92	
	<u>100-1230-7090-6026</u>		EQUIP SUPPLIES/MAINT (49.57	
	<u>700-4050-7090-0000</u>		EQUIPMENT SUPPLIES/M		74.35	
1805	KONICA MINOLTA BUSINESS SOLUTIONS	05/09/2019	Regular	0.00	1,440.93	101958
Payable #	Payable Type	Post Date	Payable Description	Discount Amount	Payable Amount	
	Account Number	Account Name	Item Description	Distribution Amount		
<u>9005652899</u>	Invoice	05/08/2019	EQUIPMENT MAINTENANCE	0.00	138.46	
	<u>100-1230-7090-0000</u>		EQUIPMENT SUPPLIES/M		138.46	
<u>9005652977</u>	Invoice	05/08/2019	PRINTER SERVICES	0.00	1,302.47	
	<u>100-1230-7090-6025</u>		EQUIP SUPPLIES/MAINT (596.25	
	<u>100-1230-7090-6040</u>		EQUIP SUPPLIES/MAINT (312.91	
	<u>100-1230-7090-6045</u>		EQUIP SUPPLIES/MAINT (229.20	
	<u>750-7000-7090-0000</u>		EQUIPMENT SUPPLIES/M		164.11	
1827	LANGUAGE TESTING INTERNATIONAL	05/09/2019	Regular	0.00	140.00	101959
Payable #	Payable Type	Post Date	Payable Description	Discount Amount	Payable Amount	
	Account Number	Account Name	Item Description	Distribution Amount		
<u>L26958-IN</u>	Invoice	05/08/2019	HIRING COSTS	0.00	140.00	
	<u>100-1240-6050-0000</u>		RECRUITMENT AND HIRI		140.00	
1831	LAURA'S CUSTOM EMBROIDERY	05/09/2019	Regular	0.00	9.00	101960
Payable #	Payable Type	Post Date	Payable Description	Discount Amount	Payable Amount	
	Account Number	Account Name	Item Description	Distribution Amount		
<u>2276</u>	Invoice	05/08/2019	EMPLOYEE UNIFORM	0.00	9.00	
	<u>100-2050-7065-0000</u>		UNIFORMS		9.00	
1856	LEXISNEXIS RISK SOLUTIONS	05/09/2019	Regular	0.00	171.70	101961
Payable #	Payable Type	Post Date	Payable Description	Discount Amount	Payable Amount	
	Account Number	Account Name	Item Description	Distribution Amount		
<u>1535776-201903</u>	Invoice	05/08/2019	Lexis Nexis Subscription	0.00	171.70	
	<u>100-2050-7030-0000</u>		DUES & SUBSCRIPTIONS		171.70	
1895	M BREY ELECTRIC INC	05/09/2019	Regular	0.00	2,990.00	101962
Payable #	Payable Type	Post Date	Payable Description	Discount Amount	Payable Amount	
	Account Number	Account Name	Item Description	Distribution Amount		
<u>5020</u>	Invoice	05/08/2019	service	0.00	2,990.00	
	<u>100-1550-7085-0000</u>		BUILDING SUPPLIES/MAI		2,990.00	
1904	MARCEDES CASHMER	05/09/2019	Regular	0.00	347.29	101963

Check Report

Date Range: 05/02/2019 - 05/09/2019

Vendor Number	Vendor Name	Payment Date	Payment Type	Discount Amount	Payment Amount	Number
Payable #	Payable Type	Post Date	Payable Description	Discount Amount	Payable Amount	
	Account Number	Account Name	Item Description	Distribution Amount		
<u>05/07/19</u>	Invoice	05/08/2019	ADVERTISING EXPENSE	0.00	119.40	
	<u>100-2050-7020-0000</u>		ADVERTISING		119.40	
<u>05/07/19-2</u>	Invoice	05/08/2019	ADVERTISING EXPENSE	0.00	119.88	
	<u>100-2050-7020-0000</u>		ADVERTISING		119.88	
<u>3901957899157</u>	Invoice	05/08/2019	REIMBURSEMENT FOR DEPT SUPPLIES	0.00	108.01	
	<u>100-2050-7025-0000</u>		OFFICE SUPPLIES		108.01	
3530	MOBILE HOMES ACCEPTANCE CORP	05/09/2019	Regular	0.00	3,057.22	101964
Payable #	Payable Type	Post Date	Payable Description	Discount Amount	Payable Amount	
	Account Number	Account Name	Item Description	Distribution Amount		
<u>213745</u>	Invoice	05/08/2019	EQUIPMENT RENTAL	0.00	3,057.22	
	<u>700-4050-7075-0000</u>		EQUIPMENT LEASING/RE		3,057.22	
2892	MOFFATT & NICHOL	05/09/2019	Regular	0.00	33,857.57	101965
Payable #	Payable Type	Post Date	Payable Description	Discount Amount	Payable Amount	
	Account Number	Account Name	Item Description	Distribution Amount		
<u>740578</u>	Invoice	05/08/2019	ENVIROMENTAL DOC SERVICES FOR PENN	0.00	6,087.53	
	<u>500-0000-7068-0000</u>		CONTRACTUAL SERVICE		6,087.53	
<u>740591</u>	Invoice	05/08/2019	ENVIROMENTAL DOC SERVICES FOR PENN	0.00	375.00	
	<u>500-0000-7068-0000</u>		CONTRACTUAL SERVICE		375.00	
<u>740592</u>	Invoice	05/08/2019	ENVIROMENTAL DOC SERVICES FOR PENN	0.00	3,098.00	
	<u>500-0000-7068-0000</u>		CONTRACTUAL SERVICE		3,098.00	
<u>741362</u>	Invoice	05/08/2019	ENVIROMENTAL DOC SERVICES FOR PENN	0.00	21,996.04	
	<u>500-0000-7068-0000</u>		CONTRACTUAL SERVICE		21,996.04	
<u>741367</u>	Invoice	05/08/2019	ENVIROMENTAL DOC SERVICES FOR PENN	0.00	1,111.00	
	<u>500-0000-7068-0000</u>		CONTRACTUAL SERVICE		1,111.00	
<u>741368</u>	Invoice	05/08/2019	ENVIROMENTAL DOC SERVICES FOR PENN	0.00	1,190.00	
	<u>500-0000-7068-0000</u>		CONTRACTUAL SERVICE		1,190.00	
1984	NAPA AUTO PARTS	05/09/2019	Regular	0.00	151.81	101966
Payable #	Payable Type	Post Date	Payable Description	Discount Amount	Payable Amount	
	Account Number	Account Name	Item Description	Distribution Amount		
<u>078915</u>	Invoice	05/08/2019	VEHICLE MAINTENANCE	0.00	40.90	
	<u>100-2050-7037-0000</u>		VEHICLE MAINTENANCE		40.90	
<u>088921</u>	Invoice	05/08/2019	VEHICLE MAINTENANCE	0.00	20.46	
	<u>100-3250-7037-0000</u>		VEHICLE MAINTENANCE		20.46	
<u>089091</u>	Invoice	05/08/2019	VEHICLE MAINTENANCE	0.00	90.45	
	<u>100-3250-7037-0000</u>		VEHICLE MAINTENANCE		90.45	
2007	NV5, INC	05/09/2019	Regular	0.00	17,118.75	101967
Payable #	Payable Type	Post Date	Payable Description	Discount Amount	Payable Amount	
	Account Number	Account Name	Item Description	Distribution Amount		
<u>120987</u>	Invoice	05/08/2019	INSPECTION SERVICES	0.00	433.75	
	<u>100-3100-7067-0000</u>		INSPECTIONS		433.75	
<u>120988</u>	Invoice	05/08/2019	INSPECTION SERVICES	0.00	469.25	
	<u>100-3100-7067-0000</u>		INSPECTIONS		469.25	
<u>120989</u>	Invoice	05/08/2019	INSPECTION SERVICES	0.00	675.00	
	<u>100-3100-7067-0000</u>		INSPECTIONS		675.00	
<u>120990</u>	Invoice	05/08/2019	INSPECTION SERVICES	0.00	884.50	
	<u>100-3100-7067-0000</u>		INSPECTIONS		884.50	
<u>120991</u>	Invoice	05/08/2019	INSPECTION SERVICES	0.00	808.25	
	<u>100-3100-7067-0000</u>		INSPECTIONS		808.25	
<u>120992</u>	Invoice	05/08/2019	INSPECTION SERVICES	0.00	230.00	
	<u>100-3100-7067-0000</u>		INSPECTIONS		230.00	

Check Report

Date Range: 05/02/2019 - 05/09/2019

Vendor Number	Vendor Name	Payment Date	Payment Type	Discount Amount	Payment Amount	Number
120993	Invoice 100-3100-7067-0000	05/08/2019	INSPECTION SERVICES INSPECTIONS	0.00	267.50 267.50	
120994	Invoice 100-3100-7067-0000	05/08/2019	INSPECTION SERVICES INSPECTIONS	0.00	173.50 173.50	
120995	Invoice 100-3100-7067-0000	05/08/2019	INSPECTION SERVICES INSPECTIONS	0.00	1,734.75 1,734.75	
120996	Invoice 100-3100-7067-0000	05/08/2019	INSPECTION SERVICES INSPECTIONS	0.00	324.00 324.00	
120997	Invoice 100-3100-7067-0000	05/08/2019	INSPECTION SERVICES INSPECTIONS	0.00	173.50 173.50	
120998	Invoice 100-3100-7067-0000	05/08/2019	INSPECTION SERVICES INSPECTIONS	0.00	361.75 361.75	
120999	Invoice 100-3100-7067-0000	05/08/2019	INSPECTION SERVICES INSPECTIONS	0.00	199.50 199.50	
121000	Invoice 100-3100-7067-0000	05/08/2019	INSPECTION SERVICES INSPECTIONS	0.00	939.00 939.00	
121001	Invoice 100-3100-7067-0000	05/08/2019	INSPECTION SERVICES INSPECTIONS	0.00	2,364.00 2,364.00	
121002	Invoice 100-3100-7067-0000	05/08/2019	INSPECTION SERVICES INSPECTIONS	0.00	1,064.50 1,064.50	
121003	Invoice 100-3100-7067-0000	05/08/2019	INSPECTION SERVICES INSPECTIONS	0.00	369.75 369.75	
121004	Invoice 100-3100-7067-0000	05/08/2019	INSPECTION SERVICES INSPECTIONS	0.00	201.75 201.75	
121005	Invoice 100-3100-7067-0000	05/08/2019	INSPECTION SERVICES INSPECTIONS	0.00	240.75 240.75	
121006	Invoice 100-3100-7067-0000	05/08/2019	INSPECTION SERVICES INSPECTIONS	0.00	230.00 230.00	
121007	Invoice 100-3100-7067-0000	05/08/2019	INSPECTION SERVICES INSPECTIONS	0.00	442.25 442.25	
121008	Invoice 100-3100-7067-0000	05/08/2019	INSPECTION SERVICES INSPECTIONS	0.00	141.75 141.75	
121009	Invoice 100-3100-7067-0000	05/08/2019	INSPECTION SERVICES INSPECTIONS	0.00	199.50 199.50	
121010	Invoice 100-3100-7067-0000	05/08/2019	INSPECTION SERVICES INSPECTIONS	0.00	225.75 225.75	
121011	Invoice 100-3100-7067-0000	05/08/2019	INSPECTION SERVICES INSPECTIONS	0.00	362.25 362.25	
121012	Invoice 100-3100-7067-0000	05/08/2019	INSPECTION SERVICES INSPECTIONS	0.00	141.75 141.75	
121013	Invoice 100-3100-7067-0000	05/08/2019	INSPECTION SERVICES INSPECTIONS	0.00	322.25 322.25	
121015	Invoice 100-3100-7067-0000	05/08/2019	INSPECTION SERVICES INSPECTIONS	0.00	428.50 428.50	
121016	Invoice 100-3100-7067-0000	05/08/2019	INSPECTION SERVICES INSPECTIONS	0.00	430.25 430.25	
121017	Invoice 100-3100-7067-0000	05/08/2019	INSPECTION SERVICES INSPECTIONS	0.00	1,195.00 1,195.00	
121018	Invoice 100-3100-7067-0000	05/08/2019	INSPECTION SERVICES INSPECTIONS	0.00	1,084.50 1,084.50	
	Void	05/09/2019	Regular	0.00	0.00	101968
	Void	05/09/2019	Regular	0.00	0.00	101969

Check Report

Date Range: 05/02/2019 - 05/09/2019

Vendor Number	Vendor Name	Payment Date	Payment Type	Discount Amount	Payment Amount	Number
2009	O'REILLY AUTO PARTS	05/09/2019	Regular	0.00	528.06	101970
Payable #	Payable Type	Post Date	Payable Description	Discount Amount	Payable Amount	
	Account Number		Account Name		Distribution Amount	
2678-167866	Invoice	05/08/2019	VEHICLE MAINTENANCE	0.00	54.91	
	100-2050-7037-0000		VEHICLE MAINTENANCE		54.91	
2678-183547	Invoice	05/08/2019	VEHICLE MAINTENANCE	0.00	86.18	
	100-2050-7037-0000		VEHICLE MAINTENANCE		86.18	
2678-184589	Invoice	05/08/2019	VEHICLE MAINTENANCE	0.00	228.43	
	100-2050-7037-0000		VEHICLE MAINTENANCE		228.43	
2678-185085	Credit Memo	05/08/2019	RETURNED PARTS	0.00	-228.43	
	100-2050-7037-0000		VEHICLE MAINTENANCE		-228.43	
2678-185116	Invoice	05/08/2019	VEHICLE MAINTENANCE	0.00	152.42	
	100-2050-7037-0000		VEHICLE MAINTENANCE		152.42	
2678-186515	Invoice	05/08/2019	VEHICLE MAINTENANCE	0.00	2.63	
	100-2050-7037-0000		VEHICLE MAINTENANCE		2.63	
2678-186769	Invoice	05/08/2019	VEHICLE MAINTENANCE	0.00	170.42	
	100-2050-7037-0000		VEHICLE MAINTENANCE		170.42	
2678-186945	Invoice	05/08/2019	VEHICLE MAINTENANCE	0.00	61.50	
	100-2050-7037-0000		VEHICLE MAINTENANCE		61.50	
2026	PACIFIC ALARM SERVICE	05/09/2019	Regular	0.00	679.00	101971
Payable #	Payable Type	Post Date	Payable Description	Discount Amount	Payable Amount	
	Account Number		Account Name		Distribution Amount	
R 146756	Invoice	05/08/2019	SECURITY SERVICES	0.00	57.50	
	100-6000-7087-6026		SECURITY- CITY HALL BLD		57.50	
R 146757	Invoice	05/08/2019	SECURITY SERVICES	0.00	171.00	
	700-4050-7087-007A		SECURITY SERVICES		171.00	
R 146759	Invoice	05/08/2019	SECURITY SERVICES	0.00	156.00	
	700-4050-7087-005X		SECURITY SERVICES		156.00	
R 146760	Invoice	05/08/2019	SECURITY SERVICES	0.00	107.50	
	100-6000-7087-6040		SECURITY - POLICE DEPT		107.50	
R 146761	Invoice	05/08/2019	SECURITY SERVICES	0.00	55.50	
	100-6000-7087-6040		SECURITY - POLICE DEPT		55.50	
R 146764	Invoice	05/08/2019	SECURITY SERVICES	0.00	131.50	
	700-4050-7087-005X		SECURITY SERVICES		131.50	
2039	PARKHOUSE TIRE, INC.	05/09/2019	Regular	0.00	758.64	101972
Payable #	Payable Type	Post Date	Payable Description	Discount Amount	Payable Amount	
	Account Number		Account Name		Distribution Amount	
2030172796	Invoice	05/08/2019	VEHICLE MAINTENANCE	0.00	96.09	
	100-6050-7037-0000		VEHICLE MAINTENANCE		96.09	
2030175499	Invoice	05/08/2019	VEHICLE MAINTENANCE	0.00	407.37	
	100-2050-7037-0000		VEHICLE MAINTENANCE		407.37	
2030175562	Invoice	05/08/2019	VEHICLE MAINTENANCE	0.00	255.18	
	100-2050-7037-0000		VEHICLE MAINTENANCE		255.18	
2051	PAYCHEX HUMAN RESOURCES SERVICES	05/09/2019	Regular	0.00	700.00	101973

Check Report

Date Range: 05/02/2019 - 05/09/2019

Vendor Number	Vendor Name	Payment Date	Payment Type	Discount Amount	Payment Amount	Number
Payable #	Payable Type	Post Date	Payable Description	Discount Amount	Payable Amount	
	Account Number	Account Name	Item Description	Distribution Amount		
9949708	05/04/1	Invoice	05/08/2019	TIMECLOCK CHARGES	0.00	700.00
	100-1240-7068-0000	CONTRACTUAL SERVICES	TIMECLOCK CHARGES		350.00	
	700-4050-7068-0000	CONTRACTUAL SERVICES	TIMECLOCK CHARGES		70.00	
	750-7000-7068-0000	CONTRACTUAL SERVICES	TIMECLOCK CHARGES		9.80	
	750-7100-7068-0000	CONTRACTUAL SERVICES	TIMECLOCK CHARGES		19.60	
	750-7200-7068-0000	CONTRACTUAL SERVICES	TIMECLOCK CHARGES		100.80	
	750-7300-7068-0000	CONTRACTUAL SERVICES	TIMECLOCK CHARGES		140.00	
	750-7400-7068-0000	CONTRACTUAL EXPENSES	TIMECLOCK CHARGES		9.80	
2065	PITNEY BOWES INC-CTR	05/09/2019	Regular	0.00	160.42	101974
Payable #	Payable Type	Post Date	Payable Description	Discount Amount	Payable Amount	
	Account Number	Account Name	Item Description	Distribution Amount		
1012386548	Invoice	05/08/2019	OFFICE SUPPLIES	0.00	160.42	
	100-2050-7025-0000	OFFICE SUPPLIES	OFFICE SUPPLIES		160.42	
2072	POLYDYNE, INC.	05/09/2019	Regular	0.00	5,745.57	101975
Payable #	Payable Type	Post Date	Payable Description	Discount Amount	Payable Amount	
	Account Number	Account Name	Item Description	Distribution Amount		
1345905	Invoice	05/08/2019	CHEMICALS & SUPPLIES	0.00	5,745.57	
	700-4050-7070-0000	SPECIAL DEPT SUPPLIES	CHEMICALS & SUPPLIES		5,745.57	
2076	PRINTING & PROMOTION PLUS, INC.	05/09/2019	Regular	0.00	683.78	101976
Payable #	Payable Type	Post Date	Payable Description	Discount Amount	Payable Amount	
	Account Number	Account Name	Item Description	Distribution Amount		
72661	Invoice	05/08/2019	OFFICE SUPPLIES	0.00	683.78	
	100-1200-7025-0000	OFFICE SUPPLIES	OFFICE SUPPLIES		683.78	
2091	PURCHASE POWER-1183	05/09/2019	Regular	0.00	503.50	101977
Payable #	Payable Type	Post Date	Payable Description	Discount Amount	Payable Amount	
	Account Number	Account Name	Item Description	Distribution Amount		
8000-9000-0779-	Invoice	05/08/2019	OFFICE SUPPLIES	0.00	503.50	
	100-2050-7025-0000	OFFICE SUPPLIES	OFFICE SUPPLIES		503.50	
2098	QUILL CORPORATON	05/09/2019	Regular	0.00	748.12	101978
Payable #	Payable Type	Post Date	Payable Description	Discount Amount	Payable Amount	
	Account Number	Account Name	Item Description	Distribution Amount		
6668742	Invoice	05/08/2019	OFFICE SUPPLIES	0.00	128.81	
	100-2050-7025-0000	OFFICE SUPPLIES	OFFICE SUPPLIES		128.81	
6736931	Invoice	05/08/2019	OFFICE SUPPLIES	0.00	406.31	
	100-1200-7025-0000	OFFICE SUPPLIES	OFFICE SUPPLIES		349.43	
	100-3100-7025-0000	OFFICE SUPPLIES	OFFICE SUPPLIES		28.44	
	700-4050-7025-0000	OFFICE SUPPLIES	OFFICE SUPPLIES		28.44	
6825476	Invoice	05/08/2019	OFFICE SUPPLIES	0.00	104.43	
	100-1200-7025-0000	OFFICE SUPPLIES	OFFICE SUPPLIES		104.43	
6829563	Invoice	05/08/2019	OFFICE SUPPLIES	0.00	11.63	
	100-1200-7025-0000	OFFICE SUPPLIES	OFFICE SUPPLIES		11.63	
6958868	Invoice	05/08/2019	OFFICE SUPPLIES	0.00	96.94	
	100-2050-7025-0000	OFFICE SUPPLIES	OFFICE SUPPLIES		96.94	
2104	RAMONA HUMANE SOCIETY INC	05/09/2019	Regular	0.00	4,020.68	101979
Payable #	Payable Type	Post Date	Payable Description	Discount Amount	Payable Amount	
	Account Number	Account Name	Item Description	Distribution Amount		
COB04302 04/30	Invoice	05/08/2019	Ramona Humane Society Shelter	0.00	4,020.68	
	100-2000-7068-0000	CONTRACTUAL SERVICES	Ramona Humane Society Shelte		4,020.68	
3616	REBEKAH BAILEY	05/09/2019	Regular	0.00	161.58	101980

Check Report

Date Range: 05/02/2019 - 05/09/2019

Vendor Number	Vendor Name	Payment Date	Payment Type	Discount Amount	Payment Amount	Number
Payable #	Payable Type	Post Date	Payable Description	Discount Amount	Payable Amount	
	Account Number	Account Name	Item Description	Distribution Amount		
<u>07-072054-02</u>	Invoice <u>100-0000-1400-0000</u>	05/08/2019	REIMBURSE CREDIT OF FINALED UTILITY A A/R - UTILITIES	0.00	161.58	
2214	RTA	05/09/2019	Regular	0.00	434.15	101981
<u>19453 04/26/19</u>	Invoice <u>100-0000-1475-0000</u>	05/08/2019	RTA BUS PASSES INVENTORY - RTA TICKETS	0.00	434.15	
1113	RYAN M. WESTBROOK INC	05/09/2019	Regular	0.00	156.00	101982
<u>669559</u>	Invoice <u>100-2000-7068-0000</u>	05/08/2019	ANIMAL CARE SERVICES CONTRACTUAL SERVICES	0.00	156.00	
2261	SEAN THUILLIEZ	05/09/2019	Regular	0.00	25.00	101983
<u>04/01/19</u>	Invoice <u>100-2050-7035-0000</u>	05/08/2019	LOCAL MEETING LOCAL MEETINGS	0.00	25.00	
2267	SGP DESIGN AND PRINT	05/09/2019	Regular	0.00	153.31	101984
<u>11159</u>	Invoice <u>100-2050-7025-0000</u>	05/08/2019	OFFICE SUPPLIES OFFICE SUPPLIES	0.00	153.31	
2289	SIMPLIFILE	05/09/2019	Regular	0.00	782.00	101985
<u>CATWAQ-043020</u>	Invoice <u>100-1200-7068-0000</u> <u>100-3100-7068-0000</u>	05/08/2019	PROFESSIONAL SERVICES CONTRACTUAL SERVICES CONTRACTUAL SERVICES	0.00	782.00 779.00 3.00	
2309	SOUTH COAST AQMD	05/09/2019	Regular	0.00	930.86	101986
<u>3444573</u>	Invoice <u>700-4050-7022-0000</u>	05/08/2019	CALIFORNIA AIR TOXICS PROGRAM FEE IN LICENSE, PERMITS, FEES	0.00	132.98	
<u>3445148</u>	Invoice <u>700-4050-7022-0000</u>	05/08/2019	CALIFORNIA AIR TOXICS PROGRAM FEE IN LICENSE, PERMITS, FEES	0.00	132.98	
<u>3447901</u>	Invoice <u>700-4050-7022-003X</u>	05/08/2019	CALIFORNIA AIR TOXICS PROGRAM FEE IN LICENSE, PERMITS, FEES	0.00	132.98	
<u>3447902</u>	Invoice <u>700-4050-7022-0000</u>	05/08/2019	CALIFORNIA AIR TOXICS PROGRAM FEE IN LICENSE, PERMITS, FEES	0.00	132.98	
<u>3448152</u>	Invoice <u>700-4050-7022-002X</u>	05/08/2019	CALIFORNIA AIR TOXICS PROGRAM FEE IN LICENSE, PERMITS, FEES	0.00	132.98	
<u>3448254</u>	Invoice <u>700-4050-7022-007A</u>	05/08/2019	CALIFORNIA AIR TOXICS PROGRAM FEE IN LICENSE, PERMITS, FEES	0.00	132.98	
<u>3448310</u>	Invoice <u>700-4050-7022-005X</u>	05/08/2019	CALIFORNIA AIR TOXICS PROGRAM FEE IN LICENSE, PERMITS, FEES -	0.00	132.98	
2311	SOUTHERN CALIFORNIA EDISON	05/09/2019	Regular	0.00	3,742.77	101987

Check Report

Date Range: 05/02/2019 - 05/09/2019

Vendor Number	Vendor Name	Payment Date	Payment Type	Discount Amount	Payment Amount	Number
Payable #	Payable Type	Post Date	Payable Description	Discount Amount	Payable Amount	
	Account Number	Account Name	Item Description	Distribution Amount		
<u>05/08/19</u>	Invoice	05/08/2019	ELECTRIC UTILITY	0.00	3,742.77	
	<u>100-3250-7010-0000</u>		UTILITIES		1,998.53	
	<u>100-3250-7010-004X</u>		UTILITIES (IA 4)		62.35	
	<u>100-3250-7010-007A</u>		UTILITIES (IA 7A)		98.99	
	<u>100-3250-7010-007D</u>		UTILITIES (IA 7D)		86.56	
	<u>100-3250-7010-008A</u>		UTILITIES (IA 8A)		346.20	
	<u>100-3250-7010-008B</u>		UTILITIES (IA 8B)		65.20	
	<u>100-3250-7010-008C</u>		UTILITIES (IA 8C)		155.33	
	<u>100-3250-7010-008D</u>		UTILITIES (IA 8D)		19.05	
	<u>100-3250-7010-010A</u>		UTILITIES (IA 10)		38.47	
	<u>100-3250-7010-012A</u>		UTILITIES (IA 12)		71.52	
	<u>100-3250-7010-014X</u>		UTILITIES (IA 14)		18.55	
	<u>100-3250-7010-019A</u>		UTILITIES (IA 19A)		171.38	
	<u>100-3250-7010-019C</u>		UTILITIES (IA 19C)		168.74	
	<u>100-3250-7010-06A1</u>		UTILITIES (IA 6A1)		301.07	
	<u>100-6050-7010-0000</u>		UTILITIES		140.83	
2316	SOUTHLAND PETROLEUM INC	05/09/2019	Regular	0.00	610.57	101988
Payable #	Payable Type	Post Date	Payable Description	Discount Amount	Payable Amount	
	Account Number	Account Name	Item Description	Distribution Amount		
<u>1111</u>	Invoice	05/08/2019	VEHICLE MAINTENANCE 09/2018-02/201	0.00	610.57	
	<u>100-2050-7037-0000</u>		VEHICLE MAINTENANCE		610.57	
2419	THE RECORD GAZETTE	05/09/2019	Regular	0.00	595.00	101989
Payable #	Payable Type	Post Date	Payable Description	Discount Amount	Payable Amount	
	Account Number	Account Name	Item Description	Distribution Amount		
<u>00968262</u>	Invoice	05/08/2019	ADVERTISING	0.00	595.00	
	<u>100-1200-7020-0000</u>		ADVERTISING		595.00	
2442	TOP-LINE INDUSTRIAL SUPPLY	05/09/2019	Regular	0.00	15.82	101990
Payable #	Payable Type	Post Date	Payable Description	Discount Amount	Payable Amount	
	Account Number	Account Name	Item Description	Distribution Amount		
<u>412089</u>	Invoice	05/08/2019	VEHICLE MAINTENANCE	0.00	15.82	
	<u>100-3250-7037-0000</u>		VEHICLE MAINTENANCE		15.82	
2456	TURF STAR, INC.	05/09/2019	Regular	0.00	168,491.68	101991
Payable #	Payable Type	Post Date	Payable Description	Discount Amount	Payable Amount	
	Account Number	Account Name	Item Description	Distribution Amount		
<u>3295710-00</u>	Invoice	05/08/2019	EQUIPMENT	0.00	143,291.84	
	<u>100-6050-8040-0000</u>		EQUIPMENT		143,291.84	
<u>3295711-00</u>	Invoice	05/08/2019	EQUIPMENT	0.00	24,164.44	
	<u>100-6050-8040-0000</u>		EQUIPMENT		24,164.44	
<u>7051063-00</u>	Invoice	05/08/2019	EQUIPMENT MAINTENANCE	0.00	1,035.40	
	<u>100-6050-7090-0000</u>		EQUIPMENT SUPPLIES/M		1,035.40	
2457	TYLER WORKS - TECHNOLOGIES	05/09/2019	Regular	0.00	50.00	101992
Payable #	Payable Type	Post Date	Payable Description	Discount Amount	Payable Amount	
	Account Number	Account Name	Item Description	Distribution Amount		
<u>025-256732</u>	Invoice	05/08/2019	MONTHLY SUPPORT FEE	0.00	50.00	
	<u>100-1230-7068-0000</u>		CONTRACTUAL SERVICES		50.00	
2484	VERIZON	05/09/2019	Regular	0.00	2,380.06	101993
Payable #	Payable Type	Post Date	Payable Description	Discount Amount	Payable Amount	
	Account Number	Account Name	Item Description	Distribution Amount		
<u>9828800478</u>	Invoice	05/08/2019	PD AIRCARDS	0.00	1,377.66	
	<u>100-1230-7015-0000</u>		TELEPHONE		1,377.66	
<u>9828985698</u>	Invoice	05/08/2019	TRANSIT TABLETS	0.00	798.21	

Check Report

Date Range: 05/02/2019 - 05/09/2019

Vendor Number	Vendor Name	Payment Date	Payment Type	Discount Amount	Payment Amount	Number
	<u>750-7200-7015-0000</u>	TELEPHONE	TRANSIT TABLETS		798.21	
<u>9828985699</u>	Invoice	05/08/2019	IPADS - 1550	0.00	76.02	
	<u>100-1230-7015-0000</u>	TELEPHONE	IPADS - 1550		76.02	
<u>9828985700</u>	Invoice	05/08/2019	IPADS - 3100	0.00	76.02	
	<u>100-1230-7015-0000</u>	TELEPHONE	IPADS - 3100		76.02	
<u>9828985701</u>	Invoice	05/08/2019	IPADS - 1550/6050	0.00	52.15	
	<u>100-1230-7015-0000</u>	TELEPHONE	IPADS - 1550/6050		52.15	
2490	VERIZON BUSINESS SERVICE	05/09/2019	Regular	0.00	1,534.79	101994
Payable #	Payable Type	Post Date	Payable Description	Discount Amount	Payable Amount	
	Account Number		Account Name	Item Description	Distribution Amount	
<u>71098733</u>	Invoice	05/08/2019	PHONE UTILITY	0.00	1,534.79	
	<u>100-1230-7015-0000</u>	TELEPHONE	PHONE UTILITY		1,534.79	
2516	VOHNE LICHE KENNELS INC	05/09/2019	Regular	0.00	125.00	101995
Payable #	Payable Type	Post Date	Payable Description	Discount Amount	Payable Amount	
	Account Number		Account Name	Item Description	Distribution Amount	
<u>15675</u>	Invoice	05/08/2019	EMPLOYEE EDUCATION	0.00	125.00	
	<u>100-2080-7066-0000</u>	TRAVEL, EDUCATION, TRA	EMPLOYEE EDUCATION		125.00	
3422	WAXIE SANITARY SUPPLY	05/09/2019	Regular	0.00	581.60	101996
Payable #	Payable Type	Post Date	Payable Description	Discount Amount	Payable Amount	
	Account Number		Account Name	Item Description	Distribution Amount	
<u>78229250</u>	Invoice	05/08/2019	BUILDING SUPPLIES	0.00	436.22	
	<u>750-7000-7085-0000</u>	BUILDING SUPPLIES/MAI	BUILDING SUPPLIES		436.22	
<u>78232424</u>	Invoice	05/08/2019	BUILDING SUPPLIES	0.00	145.38	
	<u>750-7000-7085-0000</u>	BUILDING SUPPLIES/MAI	BUILDING SUPPLIES		145.38	
2538	WEST COAST LIGHTS & SIRENS	05/09/2019	Regular	0.00	20,928.47	101997
Payable #	Payable Type	Post Date	Payable Description	Discount Amount	Payable Amount	
	Account Number		Account Name	Item Description	Distribution Amount	
<u>18304</u>	Invoice	05/08/2019	Outfitting of 2 Patrol Vehicles and 1 Admi	0.00	15,933.59	
	<u>100-2050-8060-0000</u>	VEHICLES	Outfitting of 2 Patrol Vehicles an		15,933.59	
<u>18308</u>	Invoice	05/08/2019	Outfitting of 2 Patrol Vehicles and 1 Admi	0.00	4,994.88	
	<u>100-2050-8060-0000</u>	VEHICLES	Outfitting of 2 Patrol Vehicles an		4,994.88	
2540	WESTERN RIVERSIDE COUNTY REGIONAL CONS	05/09/2019	Regular	0.00	119,928.00	101998
Payable #	Payable Type	Post Date	Payable Description	Discount Amount	Payable Amount	
	Account Number		Account Name	Item Description	Distribution Amount	
<u>APR 2019</u>	Invoice	05/08/2019	APRIL 2019 MSHCP FEES	0.00	119,928.00	
	<u>570-0000-2005-0000</u>	DUE TO WRCRCA (MSHCP	APRIL 2019 MSHCP FEES		119,928.00	
3613	WILLIE MENDOZA	05/09/2019	Regular	0.00	2,765.00	101999
Payable #	Payable Type	Post Date	Payable Description	Discount Amount	Payable Amount	
	Account Number		Account Name	Item Description	Distribution Amount	
<u>04/25/19</u>	Invoice	05/08/2019	NEW CARPET	0.00	2,765.00	
	<u>500-0000-8014-0000</u>	BUILDING IMPROVEMEN	NEW CARPET		2,765.00	
2946	Z & K CONSULTANTS, INC.	05/09/2019	Regular	0.00	3,080.00	102000
Payable #	Payable Type	Post Date	Payable Description	Discount Amount	Payable Amount	
	Account Number		Account Name	Item Description	Distribution Amount	
<u>1</u>	Invoice	05/08/2019	CONSULTING SERVICES	0.00	3,080.00	
	<u>710-0000-7068-0000</u>	CONTRACTUAL SERVICE	CONSULTING SERVICES		3,080.00	

Check Report

Date Range: 05/02/2019 - 05/09/2019

Vendor Number	Vendor Name	Payment Date	Payment Type	Discount Amount	Payment Amount	Number
1599	GUARDIAN LIFE INSURANCE	05/03/2019	Bank Draft	0.00	21,103.66	DFT0001276
Payable #	Payable Type	Post Date	Payable Description	Discount Amount	Payable Amount	
<u>MAY 2019</u>	Invoice	05/03/2019	GUARDIAN MAY 2019	0.00	21,103.66	
	<u>100-0000-2040-0000</u>		GUARDIAN VOLUNTARY LI		1,032.40	
	<u>100-1150-6021-0000</u>		DENTAL INSURANCE		156.40	
	<u>100-1150-6023-0000</u>		DISABILITY		48.65	
	<u>100-1150-6028-0000</u>		LIFE INSURANCE		7.00	
	<u>100-1200-6021-0000</u>		DENTAL INSURANCE		1,099.44	
	<u>100-1200-6023-0000</u>		DISABILITY		453.27	
	<u>100-1200-6027-0000</u>		VISION CARE		56.72	
	<u>100-1200-6028-0000</u>		LIFE INSURANCE		77.14	
	<u>100-1225-6021-0000</u>		DENTAL INSURANCE		48.46	
	<u>100-1225-6021-0000</u>		DENTAL INSURANCE		363.77	
	<u>100-1225-6023-0000</u>		DISABILITY		275.29	
	<u>100-1225-6027-0000</u>		VISION CARE		24.58	
	<u>100-1225-6028-0000</u>		LIFE INSURANCE		35.00	
	<u>100-1230-6021-0000</u>		DENTAL INSURANCE		156.40	
	<u>100-1230-6023-0000</u>		DISABILITY		68.74	
	<u>100-1230-6028-0000</u>		LIFE INSURANCE		7.00	
	<u>100-1240-6021-0000</u>		DENTAL INSURANCE		113.31	
	<u>100-1240-6023-0000</u>		DISABILITY		116.60	
	<u>100-1240-6028-0000</u>		LIFE INSURANCE		14.00	
	<u>100-1350-6021-0000</u>		DENTAL INSURANCE		156.40	
	<u>100-1350-6023-0000</u>		DISABILITY		59.78	
	<u>100-1350-6027-0000</u>		VISION CARE		24.58	
	<u>100-1350-6028-0000</u>		LIFE INSURANCE		7.00	
	<u>100-1550-6021-0000</u>		DENTAL INSURANCE		250.46	
	<u>100-1550-6023-0000</u>		DISABILITY		91.48	
	<u>100-1550-6027-0000</u>		VISION CARE		15.24	
	<u>100-1550-6028-0000</u>		LIFE INSURANCE		21.00	
	<u>100-2000-6023-0000</u>		DISABILITY		81.84	
	<u>100-2000-6028-0000</u>		LIFE INSURANCE		14.00	
	<u>100-2030-6021-0000</u>		DENTAL INSURANCE		17.31	
	<u>100-2030-6021-0000</u>		DENTAL INSURANCE		94.06	
	<u>100-2030-6023-0000</u>		DISABILITY		76.22	
	<u>100-2030-6027-0000</u>		VISION CARE		23.69	
	<u>100-2030-6028-0000</u>		LIFE INSURANCE		14.00	
	<u>100-2050-6021-0000</u>		DENTAL INSURANCE		371.54	
	<u>100-2050-6021-0000</u>		DENTAL INSURANCE		3,027.58	
	<u>100-2050-6023-0000</u>		DISABILITY		2,354.95	
	<u>100-2050-6027-0000</u>		VISION CARE		348.41	
	<u>100-2050-6028-0000</u>		LIFE INSURANCE		294.00	
	<u>100-2090-6021-0000</u>		DENTAL INSURANCE		1,041.11	
	<u>100-2090-6021-0000</u>		DENTAL INSURANCE		111.93	
	<u>100-2090-6023-0000</u>		DISABILITY		468.42	
	<u>100-2090-6027-0000</u>		VISION CARE		65.46	
	<u>100-2090-6028-0000</u>		LIFE INSURANCE		91.00	
	<u>100-2150-6021-0000</u>		DENTAL INSURANCE		96.92	
	<u>100-2150-6021-0000</u>		DENTAL INSURANCE		188.12	
	<u>100-2150-6023-0000</u>		DISABILITY		174.31	
	<u>100-2150-6027-0000</u>		VISION CARE		30.48	
	<u>100-2150-6028-0000</u>		LIFE INSURANCE		28.00	
	<u>100-3100-6021-0000</u>		DENTAL INSURANCE		48.46	
	<u>100-3100-6021-0000</u>		DENTAL INSURANCE		269.71	
	<u>100-3100-6023-0000</u>		DISABILITY		108.97	
	<u>100-3100-6027-0000</u>		VISION CARE		40.11	
	<u>100-3100-6028-0000</u>		LIFE INSURANCE		21.00	
	<u>100-3250-6021-0000</u>		DENTAL INSURANCE		48.46	
	<u>100-3250-6021-0000</u>		DENTAL INSURANCE		318.31	
	<u>100-3250-6023-0000</u>		DISABILITY		161.86	

Check Report

Date Range: 05/02/2019 - 05/09/2019

Vendor Number	Vendor Name	Payment Date	Payment Type	Discount Amount	Payment Amount	Number
	100-3250-6027-0000	VISION CARE	GUARDIAN MAY 2019		40.11	
	100-3250-6028-0000	LIFE INSURANCE	GUARDIAN MAY 2019		35.00	
	100-6050-6021-0000	DENTAL INSURANCE	GUARDIAN MAY 2019		179.62	
	100-6050-6021-0000	DENTAL INSURANCE	GUARDIAN MAY 2019		1,090.81	
	100-6050-6023-0000	DISABILITY	GUARDIAN MAY 2019		648.45	
	100-6050-6027-0000	VISION CARE	GUARDIAN MAY 2019		175.58	
	100-6050-6028-0000	LIFE INSURANCE	GUARDIAN MAY 2019		140.00	
	700-4050-6021-0000	DENTAL INSURANCE	GUARDIAN MAY 2019		96.92	
	700-4050-6021-0000	DENTAL INSURANCE	GUARDIAN MAY 2019		396.26	
	700-4050-6023-0000	DISABILITY	GUARDIAN MAY 2019		494.71	
	700-4050-6027-0000	VISION CARE	GUARDIAN MAY 2019		66.06	
	700-4050-6028-0000	LIFE INSURANCE	GUARDIAN MAY 2019		70.00	
	750-7000-6021-0000	DENTAL INSURANCE	GUARDIAN MAY 2019		539.42	
	750-7000-6023-0000	DISABILITY	GUARDIAN MAY 2019		156.03	
	750-7000-6027-0000	VISION CARE	GUARDIAN MAY 2019		31.06	
	750-7000-6028-0000	LIFE INSURANCE	GUARDIAN MAY 2019		28.00	
	750-7100-6021-0000	DENTAL INSURANCE	GUARDIAN MAY 2019		250.46	
	750-7100-6023-0000	DISABILITY	GUARDIAN MAY 2019		55.87	
	750-7100-6028-0000	LIFE INSURANCE	GUARDIAN MAY 2019		14.00	
	750-7200-6021-0000	DENTAL INSURANCE	GUARDIAN MAY 2019		557.40	
	750-7200-6021-0000	DENTAL INSURANCE	GUARDIAN MAY 2019		34.62	
	750-7200-6023-0000	DISABILITY	GUARDIAN MAY 2019		247.67	
	750-7200-6027-0000	VISION CARE	GUARDIAN MAY 2019		62.62	
	750-7200-6028-0000	LIFE INSURANCE	GUARDIAN MAY 2019		66.50	
	750-7300-6021-0000	DENTAL INSURANCE	GUARDIAN MAY 2019		236.72	
	750-7300-6021-0000	DENTAL INSURANCE	GUARDIAN MAY 2019		65.77	
	750-7300-6023-0000	DISABILITY	GUARDIAN MAY 2019		175.48	
	750-7300-6027-0000	VISION CARE	GUARDIAN MAY 2019		48.27	
	750-7300-6028-0000	LIFE INSURANCE	GUARDIAN MAY 2019		35.00	
	750-7400-6021-0000	DENTAL INSURANCE	GUARDIAN MAY 2019		48.60	
	750-7400-6023-0000	DISABILITY	GUARDIAN MAY 2019		31.96	
	750-7400-6027-0000	VISION CARE	GUARDIAN MAY 2019		15.24	
	750-7400-6028-0000	LIFE INSURANCE	GUARDIAN MAY 2019		7.00	
	750-7600-6021-0000	DENTAL INSURANCE	GUARDIAN MAY 2019		97.20	
	750-7600-6023-0000	DISABILITY	GUARDIAN MAY 2019		40.91	
	750-7600-6028-0000	LIFE INSURANCE	GUARDIAN MAY 2019		14.00	

2594	CAL PERS	05/07/2019	Bank Draft	0.00	30,010.10	DFT0001298
Payable #	Payable Type	Post Date	Payable Description	Discount Amount	Payable Amount	
INV0000041	Invoice	05/07/2019	PERS UNFUNDED LIAB APRIL 2019 PLAN 7	0.00	30,010.10	
	100-0000-2130-0000		P.E.R.S. LIABILITY		30,010.10	

2594	CAL PERS	05/07/2019	Bank Draft	0.00	64,088.44	DFT0001299
Payable #	Payable Type	Post Date	Payable Description	Discount Amount	Payable Amount	
INV0000042	Invoice	05/07/2019	PERS UNFUNDED LIAB APRIL 2019 PLAN 7	0.00	64,088.44	
	100-0000-2130-0000		P.E.R.S. LIABILITY		64,088.44	

2594	CAL PERS	05/07/2019	Bank Draft	0.00	85.49	DFT0001300
Payable #	Payable Type	Post Date	Payable Description	Discount Amount	Payable Amount	
INV0000043	Invoice	05/07/2019	PERS UNFUND LIAB APRIL 2019 PLAN 257	0.00	85.49	
	100-0000-2130-0000		P.E.R.S. LIABILITY		85.49	

2594	CAL PERS	05/07/2019	Bank Draft	0.00	172.77	DFT0001301
------	----------	------------	------------	------	--------	------------

Check Report

Date Range: 05/02/2019 - 05/09/2019

Vendor Number
Payable #

Vendor Name
Payable Type
Account Number
Invoice
100-0000-2130-0000

Payment Date
Payable Description
Account Name
Item Description
05/07/2019 PERS UNFUND LIAB APRIL 2019 PLAN 562
P.E.R.S. LIABILITY 100000015627201

Discount Amount
Payment Amount
Number
Discount Amount
Payable Amount
Distribution Amount
0.00 172.77
172.77

JNV0000044

Bank Code APBNK Summary

Payment Type	Payable Count	Payment Count	Discount	Payment
Regular Checks	171	83	0.00	461,531.45
Manual Checks	0	0	0.00	0.00
Voided Checks	0	2	0.00	0.00
Bank Drafts	5	5	0.00	115,460.46
EFT's	3	3	0.00	56,098.60
	179	93	0.00	633,090.51

All Bank Codes Check Summary

Payment Type	Payable Count	Payment Count	Discount	Payment
Regular Checks	171	83	0.00	461,531.45
Manual Checks	0	0	0.00	0.00
Voided Checks	0	2	0.00	0.00
Bank Drafts	5	5	0.00	115,460.46
EFT's	3	3	0.00	56,098.60
	179	93	0.00	633,090.51

Fund Summary

Fund	Name	Period	Amount
999	POOLED CASH	5/2019	633,090.51
			<u>633,090.51</u>



SCANNED

Canceled Payables

Vendor Set: 01 - Vendor Set 01

Bank: APBNK - AP Bank

Vendor Number	Vendor Name				Total Vendor Amount
<u>2908</u>	JULIO MARTINEZ				-82.36
Payment Type	Payment Number	Original Payment Date	Reversal Date	Cancel Date	Payment Amount
Check	<u>101829</u>	04/25/2019	04/25/2019	04/24/2019	-82.36
Payable Number:	Description	Payable Date	Due Date		Payable Amount
<u>03/28/19</u>	REIMBURSEMENT FOR MEETING EXPENSES	04/24/2019	04/24/2019		82.36

Bank Code Summary

Bank Code	Canceled Payables	Payables Left To Pay Again	Total
APBNK	-82.36	0.00	-82.36
Report Total:	-82.36	0.00	-82.36



MINUTES
Joint City Council and Beaumont Cherry Valley Water
District Board of Directors Meeting
Thursday, April 25, 2019

560 Magnolia Ave. Beaumont, Ca
Regular Session: 6:00 PM

REGULAR SESSION

CALL TO ORDER at 6:03 p.m.

Present: Mayor Martinez, Council Member Carroll, Council Member Lara, and Council Member White, President Covington, Director Hoffman, Director Slawson, Director Williams, and Director Ramirez

Absent: Mayor Pro Tem Santos

Public Comment Period

J. Bingham – Spoke in opposition of the MOU.

L. Uremovic – Spoke regarding previous related contracts.

ACTION ITEMS

1. Discussion and Consideration of a Recycled Water memorandum of Understanding between Beaumont-Cherry Valley Water District and the City of Beaumont

Consensus to finalize the MOU and present to each entity for approval in June 2019.

ADJOURNMENT

Adjournment of the Joint Meeting of the City Council and the Beaumont Cherry Valley Water District of April 25, 2019, at 7:37 p.m.

Beaumont City Hall – Online www.BeaumontCa.gov



MINUTES
City Council Meeting
Tuesday, May 7, 2019
Council Chambers
550 E 6th St. Beaumont, Ca
Closed Session: 5:00 PM
Regular Session: 6:00 PM

CLOSED SESSION

A Closed Session of the City Council / Beaumont Financing Authority / Beaumont Utility Authority / Beaumont Successor Agency (formerly RDA)/Beaumont Parking Authority / Beaumont Public Improvement Authority may be held in accordance with state law which may include, but is not limited to, the following types of items: personnel matters, labor negotiations, security matters, providing instructions to real property negotiators and conference with legal counsel regarding pending litigation. Any public comment on Closed Session items will be taken prior to the Closed Session. Any required announcements or discussion of Closed Session items or actions following the Closed Session will be made in the City Council Chambers.

CALL TO ORDER at 5:00 p.m.

Present: Mayor Martinez, Mayor Pro Tem Santos, Council Member Carroll, Council Member Lara, and Council Member White

1. **Public Comments Regarding Closed Session**

Public comment opened at 5:00 p.m.

A. Worthen – *Thanked the City Manager for his time spent at Four Seasons and thanked the Police Department for their presence as well.*

2. **Conference with Real property Negotiator Pursuant to Government Code Section 54956.8 for Property Known as Vacant Land APN 417-110-018. Agency Negotiator: City Manager Todd Parton or his Designee. Negotiating Parties: City of Beaumont and V4B LLC. Under Negotiation: Price and Terms.**

No reportable action.

Mayor Pro Tem Santos was not in attendance for this item.

3. **Conference with Legal Counsel Regarding Pending Litigation Pursuant to Government Code Section 54956.9(d)(1) (One Case: Beaumont adv: Urban Logic Riv Case No. 1707201)**

No reportable action.

4. **Conference with Labor Negotiator - Pursuant to Government Code Section 54957.6 City Designated Representative City Manager Todd Parton or his Designee**

- SEIU

No reportable action.

Adjourn to Closed Session

REGULAR SESSION

CALL TO ORDER at 6:11 p.m.

Present: Mayor Martinez, Mayor Pro Tem Santos, Council Member Carroll, Council Member Lara, and Council Member White

Report out from Closed Session: **See above**

Action on any Closed Session items: **None**

Action on any requests for excused absence: **None**

Pledge of Allegiance

Approval/Adjustments to Agenda: **None**

Conflict of Interest Disclosure: **None**

ANNOUNCEMENTS/RECOGNITIONS/PROCLAMATIONS/CORRESPONDENCE

PUBLIC COMMENT PERIOD (ITEMS NOT ON THE AGENDA)

Any one person may address the City Council on any matter not on this agenda. If you wish to speak, please fill out a "Public Comment Form" provided at the back table and give to the City Clerk. There is a three (3) minute time limit on public comments. There will be no sharing or passing of time to another person. State Law prohibits the Council from discussing or taking actions brought up by your comments.

Public comment opened at 6:12 p.m.

E. Mazzei – Spoke regarding concerns and issues with the street vendors

Public Comment closed at 6:17 p.m.

CONSENT CALENDAR

Items on the consent calendar are taken as one action item unless an item is pulled for further discussion here or at the end of action items.

Approval of all Ordinances and Resolutions to be read by title only.

1. Ratification of Warrants Dated April 4, 2019
2. Ratification of Warrants Dated April 11, 2019
3. Ratification of Warrants dated April 18, 2019
4. Ratification of Warrants Dated April 25, 2019
5. Approval of Minutes Dated April 16, 2019
6. Approval of Minutes Dated April 22, 2019
7. Request of Rental Fee Waiver - Kiwanis Club of Beaumont
8. Approval of Costs Greater than \$25,000 - Doublemap Inc.
9. Letter of Endorsement for the Inland Empire Regional Broadband Consortium 2019 California Advanced Services Fund Regional Broadband Consortia Grant Application
10. Bond Exoneration for Bond No. 41343392 - K. Hovnanian Homes

11. Improvement Bond Acceptance for CJ Foods and Cash Deposit Acceptance for Lassen Development
12. Waive the Full Reading and Adopt, "An Ordinance of the City Council of the City of Beaumont, California, Amending Table 17.03-3 'Permitted Uses in Base Zone District' and Table 17.03-4 'Permitted Uses in Overlay Zone Districts' within Chapter 17, 'Zoning' of the Beaumont Municipal Code"
13. February 2019 Financial Reports

Motion by Council Member White

Second by Council Member Lara

Council Member White

Council Member Lara

Council Member Carroll

Mayor Pro Tem Santos

Mayor Martinez

To approve the Consent Calendar.

Approved by a unanimous vote.

PUBLIC HEARINGS

Approval of all Ordinances and Resolutions to be read by title only

14. Introduction of Ordinance to Amend Municipal Code Chapters 5.62 and 5.70

Public hearing opened and closed at 6:21 p.m.

Motion by Council Member Lara

Second by Mayor Pro Tem Santos

Council Member White

Council Member Lara

Council Member Carroll

Mayor Pro Tem Santos

Mayor Martinez

To waive the full reading and approve the first introduction by title only, "An Ordinance of the City of Beaumont Amending Title 5, Chapter 5.62 of the City of Beaumont Municipal Code to Regulate the Personal, Medical, and Commercial Use of Marijuana; and Amending Title 5, Chapter 5.70, Regulating Marijuana Delivery." With added restrictions regarding delivery near schools.

Approved by a unanimous vote.

ACTION ITEMS

Approval of all Ordinances and Resolutions to be read by title only.

15. Hearing on Costs of Nuisance Abatement 552 N. California Avenue

Motion by Council Member White

Second by Council Member Lara

Council Member White

- Council Member Lara
- Council Member Carroll
- Mayor Pro Tem Santos
- Mayor Martinez

To waive the full reading and adopt by title only, "A Resolution of the City Council of the City of Beaumont Approving Staff's Report of Costs of Nuisance Abatement."
Approved by a unanimous vote.

16. Consideration of a Collection Services Agreement for the Provisions of Residential and Commercial Garbage, Recyclable Materials and Organic Waste Collection Services between the City of Beaumont, California and USA Waste of California, Inc. d.b.a Waste Management of the Inland Empire

City Attorney, John Pinkney recused himself on this item.

Public Comment opened at 7:16 p.m.

B. Rader – spoke in favor of a contract with Waste Management

Public Comment closed at 7:18 p.m.

Public Comment reopened at 7:31 p.m.

V. Clara – Thanked Council and staff.

Public Comment closed at 7:34 p.m.

Motion by Council Member White

Second by Mayor Pro Tem Santos

- Council Member White
- Council Member Lara
- Council Member Carroll
- Mayor Pro Tem Santos
- Mayor Martinez

To staff recommends the City Council approve a Collection Services Agreement for the Provision of Residential and Commercial Garbage, Recyclable Materials and Organic Waste Collection Services between the City of Beaumont, California and USA Waste of California, Inc. d.b.a Waste Management of the Inland Empire.

Approved by a unanimous vote.

17. Award of Citywide Uniform Contract to Prudential Overall Supply in an Amount not to Exceed \$40,000 Per Year

Motion by Council Member White

Second by Mayor Pro Tem Santos

- Council Member White
- Council Member Lara
- Council Member Carroll
- Mayor Pro Tem Santos
- Mayor Martinez

To approve a service agreement with Prudential Overall Supply with 3-year contract term, and

Authorization the City Manager to execute the agreement on behalf of the City.

Approved by a unanimous vote.

18. FY 2019/20 - 2021/22 Short Range Transit Plan - Table 4 Revision

Motion by Council Member Lara

Second by Council Member White

Council Member White

Council Member Lara

Council Member Carroll

Mayor Pro Tem Santos

Mayor Martinez

To authorize staff with the prioritization of FY 2019-2020 Transit capital projects, to prepare and resubmit the updated Table 4 with the new prioritization and the revised request of \$500,000 for Phase 1 of the administrative, fleet maintenance, and operations facility capital project.

Approved by a unanimous vote.

19. Arborist Reports for Trees Located at the Beaumont Civic Center Campus, Stewart Park, and Portions of Beaumont Avenue.

Motion by Council Member White

Second by Council Member Carroll

Council Member White

Council Member Lara

Council Member Carroll

Mayor Pro Tem Santos

Mayor Martinez

To authorize staff to award a contract to remove and prune the trees outlined in the arborist's reports, in accordance with the procurement procedures in the Beaumont Municipal Code.

Approved by a unanimous vote.

20. Award of Credit Card Processing Contract to CardConnect

Motion by Council Member Lara

Second by Council Member White

Council Member White

Council Member Lara

Council Member Carroll

Mayor Pro Tem Santos

Mayor Martinez

**To approve award of contract for credit card processing to CardConnect.
Authorize the City Manager to execute the CardConnect processing contract.
Approved by a unanimous vote.**

21. Approval of the FY 2019/20 Local Responsibility Area Wildland Protection Reimbursement Agreement

**Motion by Council Member Lara
Second by Council Member Santos**

- Council Member White
- Council Member Lara
- Council Member Carroll
- Mayor Pro Tem Santos
- Mayor Martinez

To waive the full reading and adopt by title only, "A Resolution of the City Council of the City of Beaumont, California, approving an Agreement with the California Department of Forestry and Fire Protection Services within the Local Responsibility Areas within the City."

Approve the FY 2019/20 agreement with CalFIRE for fire protection services within the Local Responsibility Areas within the City.

Approved by a unanimous vote.

22. Approve First Amendment to Professional Services Agreement with Minagar & Associates Inc., for a Total Not to Exceed \$200,000 Annually for Traffic Engineering Services

**Motion by Council Member White
Second by Mayor Martinez**

- Council Member White
- Council Member Lara
- Council Member Carroll
- Mayor Pro Tem Santos
- Mayor Martinez

To approve First Amendment to professional services agreement with Minagar & Associates, Inc., for a total not to exceed \$200,000 annually for traffic engineering services.

Approved by a unanimous vote.

23. Beaumont Municipal Pool Renovation Update

**Motion by Council Member Lara
Second by Council Member White**

- Council Member White
- Council Member Lara
- Council Member Carroll

Mayor Pro Tem Santos
 Mayor Martinez
To receive and file.
Approved by a unanimous vote.

24. 2018 General Plan Annual Progress Report

Motion by Council Member Lara
Second by Council Member Carroll

Council Member White
 Council Member Lara
 Council Member Carroll
 Mayor Pro Tem Santos
 Mayor Martinez

To approve the 2018 General Plan Annual Progress Report and direct staff to submit the report to the Governor's Office of Planning and Research, and
Waive the full reading and adopt by title only, "A Resolution of the City Council of Beaumont to approve the 2018 General Plan Annual Progress Report."
Approved by a unanimous vote.

25. Receive and File the Potrero Bridge Project Summary and Construction Change Order Update

Motion by Council Member Lara
Second by Council Member Carroll

Council Member White
 Council Member Lara
 Council Member Carroll
 Mayor Pro Tem Santos
 Mayor Martinez

To receive and file the Potrero Bridge Project Summary and Construction Change Order Update.
Approved by a unanimous vote.

26. Wastewater Treatment Plant Expansion/Renovation and Brine Pipeline Installation Project Status

Motion by Mayor Martinez
Second by Council Member Lara

Council Member White
 Council Member Lara
 Council Member Carroll
 Mayor Pro Tem Santos
 Mayor Martinez

**To receive and file the project updates.
Approved by a unanimous vote.**

27. Approval of an Emergency Purchase of a Pump for the Marshall Creek Lift Station from Xylem Inc., in the Amount of \$63,110

Motion by Council Member Lara

Second by Mayor Martinez

Council Member White

Council Member Lara

Council Member Carroll

Mayor Pro Tem Santos

Mayor Martinez

To approve the emergency purchase of a Flygt 3300 series pump for the Marshall Creek Lift Station in the amount not to exceed \$63,110.

Approved by unanimous vote.

28. Approval of Purchase Order for Quinn Company in an Amount Not to Exceed \$50,305.23 and Zero Budget Adjustment for the Wastewater Operating Fund

Motion by Council Member White

Second by Mayor Pro Tem Santos

Council Member White

Council Member Lara

Council Member Carroll

Mayor Pro Tem Santos

Mayor Martinez

To approve purchase order for Quinn Company for an amount not to exceed a total of \$50,305.23 for fiscal year 2018-2019; and

Approve net zero budget adjustment to realign existing line items for fiscal year 2018-2019.

Approved by a unanimous vote.

29. Consideration of Optional Owner Initiated Scope Changes to the Wastewater Treatment Plant Expansion and Renovation Project

Motion by Council Member White

Second by Council Member Carroll

Council Member White

Council Member Lara

Council Member Carroll

Mayor Pro Tem Santos

Mayor Martinez

To consider potential scope changes and direct the staff/design team to move forward with obtaining contractor pricing for change order consideration.

Approved by a unanimous vote.

30. City Council Approval of Change Order No. 7 for the Wastewater Treatment Plant Upgrade/Expansion Project in the Amount of \$59,167.49

Motion by Council Member White

Second by Council Member Lara

Council Member White

Council Member Lara

Council Member Carroll

Mayor Pro Tem Santos

Mayor Martinez

To approval of Change Order No. 7 for the Wastewater Treatment Plant Upgrade/Expansion Project in the amount of \$59,167.49.

Approved by a unanimous vote.

31. Fiscal Year 2019-20 Draft General Fund Budget for Review

Motion by Council Member White

Second by Mayor Martinez

Council Member White

Council Member Lara

Council Member Carroll

Mayor Pro Tem Santos

Mayor Martinez

To receive and file.

Approved by a unanimous vote.

32. Legislative Updates and Discussion

Discussion regarding current legislative issues and statuses.

33. City Attorney Invoices for the Month of April 2019

City Attorney, John Pinkney recused himself for this item.

Motion by Council Member Lara

Second by Council Member White

Council Member White

Council Member Lara

Council Member Carroll

Mayor Pro Tem Santos

Mayor Martinez

To approve invoices in the amount of \$151,516.73.

Approved by a unanimous vote.

COUNCIL REPORTS

- **Carroll** – *No report.*
- **Lara** – *Asked for an update of the Oak Valley Signalization.*
- **Martinez** – *Attended the Chamber of Commerce mixer, LEAC award ceremony, met with CJ Foods in regards to their next phase, attended a CHP press conference, attended the RCA meeting.*
- **Santos** – *Attended the SCAG conference.*
- **White** – *Asked that staff send out updated information regarding the delay in the Oak Valley Signalization project.*

ECONOMIC DEVELOPMENT UPDATE

No report.

CITY TREASURER REPORT

Finance and Audit Committee report out.

CITY CLERK REPORT

No report.

CITY ATTORNEY REPORT

34. Status of Pending Litigation Against the City of Beaumont

CITY MANAGER REPORT

Gave an update on behalf of Economic Development.

FUTURE AGENDA ITEMS

- Notification of upcoming 60 State Route truck route project.

ADJOURNMENT

Adjournment of the City Council of the May 7, 2019 Meeting at 9:54 p.m.

The next regular meeting of the Beaumont City Council, Beaumont Financing Authority, the Beaumont Successor Agency (formerly RDA), the Beaumont Utility Authority, the Beaumont Parking Authority and the Beaumont Public Improvement Agency is scheduled for Tuesday, May 21, 2019, at 5:00 p.m. or thereafter as noted on the posted Agenda for Closed Session items in the City Council Board Room No. 5, followed by the regular meeting at 6:00 p.m. or thereafter as noted on the posted Agenda at City Hall.

Beaumont City Hall – Online www.BeaumontCa.gov

Staff Report

TO: Mayor and City Council Members

FROM: Community Development Department

DATE: May 21, 2019

SUBJECT: Tentative Parcel Map 34990 (South Side of Oak Valley Parkway, East of Interstate 10) One-Year Time Extension

Background and Analysis:

The Tentative Parcel Map 34990 was approved by City Council on June 5, 2007, for a two-year period. Additionally, City Council approved a one-year extension until June 5, 2010.



Location

The following California Bills also extended the map for (7) seven years in California:

- SB 1185 – Automatic 1-year extension (Extension until June 5, 2011)
- AB 333 – Automatic 2-year extension (Extension until June 5, 2013)
- AB 208 – Automatic 2-year extension (Extension until June 5, 2015)
- AB 116 – Automatic 2-year extension (Extension until June 5, 2017)

The City Council approved an additional one-year extension for the map resulting in an expiration of June 5, 2018.

The Subdivision Map Act (66463.5(c)) allows the subdivider to apply to City Council for up to six (6) additional one-year extensions. The applicant is currently requesting their fourth

one-year extension. If approved, the map will expire on June 5, 2020, with two additional extensions possible.

The subdivision map is a "financing and conveyance map," meaning that it cannot lead directly to development nor does it require any physical improvements. An underlying plot plan would dictate the manner of site development. The function of the map is to permit the simplified conveyance of portions of the parcel to individual users, or to separate project elements for financing.

There are no unusual or changed circumstances which affect this map or the consideration of a time extension.

Fiscal Impact:

The proposed map extension has no fiscal impact.

Finance Director Review: 

Recommendation:

1. Approve a one-year extension of time for the approval of Tentative Parcel Map 34990.

City Manager Review: 

Attachments:

- A. Tentative Parcel Map 34990

TENTATIVE PARCEL MAP NO 34990

THE SHOPS AT NOBLE CREEK

BEAUMONT, CALIFORNIA



PARCEL MAP NO. 28998
 PLAN 28Y08
 ZONE: COMMERCIAL
 APN 408-40-1
 APN 408-40-2
 APN 408-40-3
 APN 408-40-4

ZONE: RESIDENTIAL
 PLAN 188-78288
 THIS IS A SUBDIVISION MAP UNDER SCHEDULE 15.12
 PARCEL MAP NO. 28992
 PLAN 188-78288
 APN 408-40-1
 APN 408-40-2
 APN 408-40-3
 APN 408-40-4

ZONE: COMMERCIAL
 APN 408-40-1
 APN 408-40-2
 APN 408-40-3
 APN 408-40-4

ZONE: RESIDENTIAL
 APN 158-390-004
 ZONE: RESIDENTIAL
 APN 158-390-004

ZONE: COMMERCIAL
 APN 411-718-006
 ZONE: COMMERCIAL
 APN 411-718-006

- LEGEND AND ABBREVIATIONS:**
- | | | | |
|--|--------------|--|----------------|
| | EASEMENT | | RIGHT OF WAY |
| | LOT | | SECTION |
| | CONTOUR | | BOUNDARY |
| | CREEK | | ROAD |
| | UTILITY LINE | | WATER LINE |
| | SEWER LINE | | GAS LINE |
| | POWER LINE | | TELEPHONE LINE |
| | OTHER | | UNLABELED |

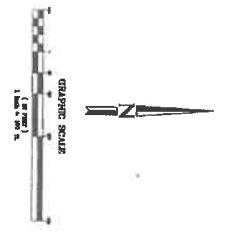

NO.	REVISION	DATE

PROJECT: **THE SHOPS AT NOBLE CREEK**
OAK VALLEY PARKWAY & HIGHWAY 10
BEAUMONT, CALIFORNIA
 TENTATIVE PARCEL MAP NO. 34990

PREPARED BY:

801 S. 74th Ave. #20
 OAKLAND, CALIF. 94619
 (415) 885-8888
 CIVIL ENGINEERING AND SURVEYING FIRM
 RONALD W. BLEPOD R.W.C. 44216 DATE

Staff Report

TO: Mayor and Council Members

FROM: Jeff Hart, Public Works Director

DATE: May 21, 2019

SUBJECT: A Resolution of the City of Beaumont Authorizing City Council to Summarily Vacate Street Right-of-Way on the Northwest Corner of Grace Avenue and Fifth Street Fronting the Precision Stamping Incorporated Building

Background and Analysis:

The applicant, Precision Stamping Incorporated (Precision Stamping), is requesting a summary street vacation of existing right-of-way on Grace Avenue and Fifth Street, the depiction of the street vacation area is provided in Attachment A. As shown in the depiction, the existing Precision Stamping building extends into street right-of-way. Grace Avenue and Fifth Street contain sidewalk, curb and gutter, and street lighting around the Precision Stamping building, which will not be part of the area to be vacated.

In conjunction with the street vacation, the applicant will reserve existing public utility easements over the street vacation area which consists of approximately 1,688 square feet. By reserving existing easements, utility purveyors will have the ability to maintain their respective utilities within Grace Avenue and Fifth Street. Within the street vacation area, the applicant does not intend on altering the existing ground nor constructing any building infrastructure. Therefore, if any utilities are located within the street vacation area which were not identified by the applicant's land surveyor, or any of the utility purveyors, they will remain undisturbed.

The City sent out a utility notice informing all pertinent utility purveyors within the City of Beaumont about the proposed street vacation. The City has received responses from the following utility purveyors:

- Beaumont Cherry Valley Water District
- Frontier Communications
- Charter (Spectrum) Communications
- Kinder Morgan
- Questar
- Southern California Gas Company
- Southern California Edison

All of the above utility purveyors indicated that the proposed street vacation will not affect

their respective utility.

The California Streets and Highway Code (SHC) allows a legislative body to process a summary street vacation in accordance with the regulations set forth in sections 8330, 8333, 8334, and 8341. The regulations entail the following:

- Require that the street vacation shall not affect in place public utilities,
- Give the local agency the ability to vacate excess street right-of-way not required for street or highway purposes,
- Require that the legislative body adopt a resolution to vacate street right-of-way, and
- Require the legislative body to document the reservation of existing public utility easements.

Staff has reviewed the California Streets and Highway Code and determined that the vacation area of approximately 1,688 square feet will not affect the City's traffic circulation element. Staff has included the reservation of existing public utility easements in the resolution document and received confirmation from all pertinent utility purveyors that their respective utility will not be affected by the proposed street vacation. Therefore, staff recommends that the City Council summarily vacate the 1,688 square feet of street right-of-way fronting Grace Avenue and Fifth Street by adopting the resolution to vacate.

Fiscal Impact:

The cost to prepare the staff report and have city attorney review the street vacation documents equates to approximately \$1,000. The applicant has paid the plan checking fees associated with plan checking the street vacation documents.

Finance Director Review: 

Recommendation:

1. Waive the full reading and adopt by title only, "A Resolution of the City of Beaumont Authorizing City Council to Summarily Vacate Street Right-of-Way from Grace Avenue and Fifth Street Fronting the Precision Stamping Incorporated Building"; and
2. Record the street vacation documents with the Riverside County Clerk Recorder's Office.

City Manager Review: 

Attachments:

- A. Google Overlay Exhibit of Street Vacation
- B. Legal Description and Accompanying Plat for Street Vacation
- C. Street Vacation Resolution
- D. California Streets and Highway Code for Street Vacation
- E. Utility Purveyor Street Vacation Notice
- F. Utility Purveyor Responses to Proposed Street Vacation

Attachment A

Google Overlay Exhibit of Street Vacation

EXHIBIT "B" - MAP

STREET VACATION NO. 18-SV-005

SECTION 9, TOWNSHIP 3 SOUTH, RANGE 1 WEST, SBBM

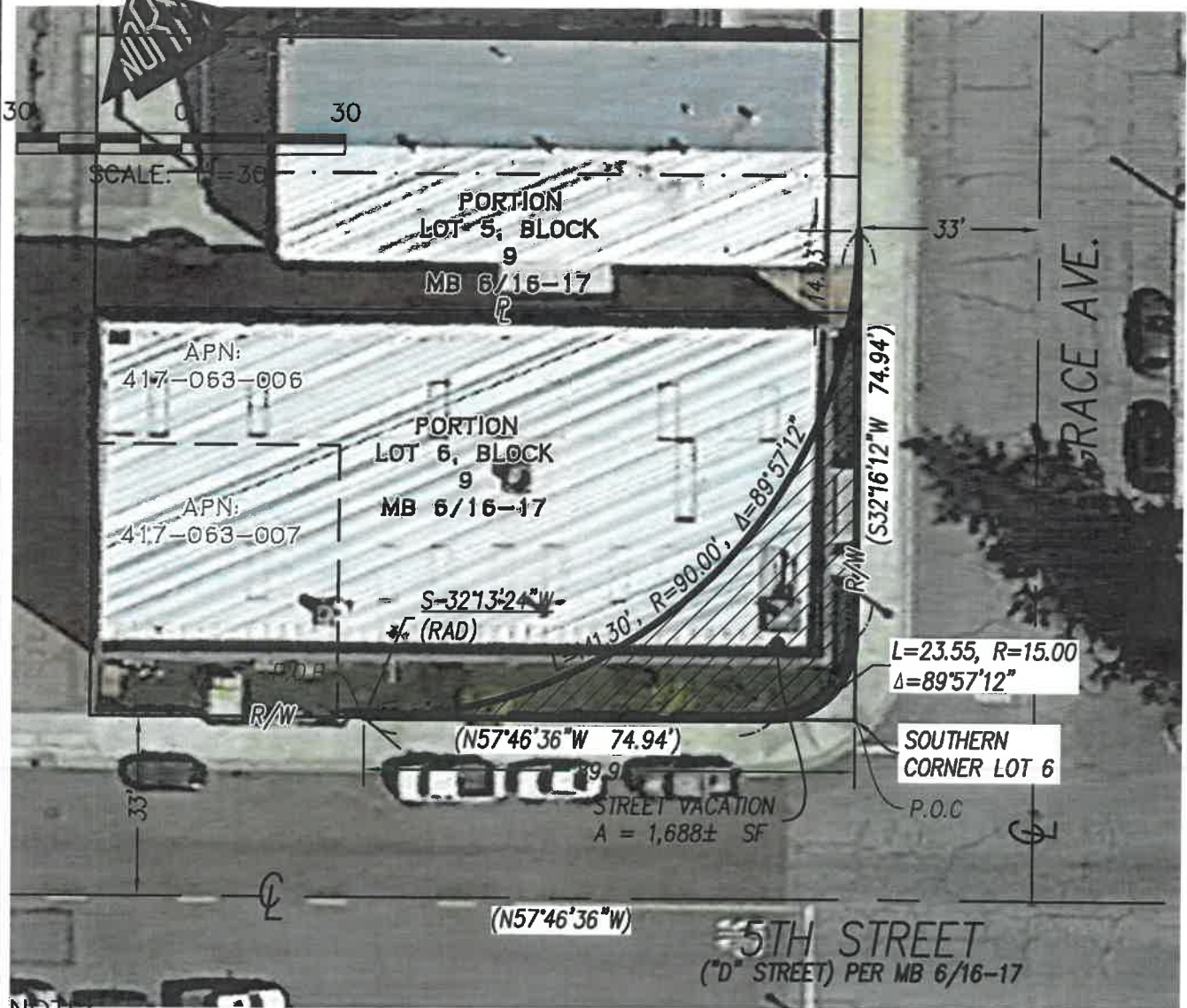

NOTE:

() REC. DATA PER MB 6/16-17

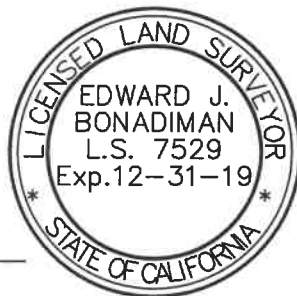

EDWARD J. BONADIMAN
EXP. 12-31-19

DATE

DRAWN BY: FA
CHECKED BY: EB
DATE: 09-13-18
JOB NO.: 184561



TEL. (909) 885-3806
234 NORTH ARROWHEAD AVE.
SAN BERNARDINO, CA 92408
FAX (909) 381-1721
www.bonadiman.com

PROJECT:
STREET VACATION
NO. 18-SV-005
APN: 417-063-006
CITY OF BEAUMONT, CA

SHT. NO.
2
OF 2

Attachment B

Legal Description and Accompanying Plat for Street Vacation

Recording Requested By:
City of Beaumont

When Recorded Mail To:
City of Beaumont Engineering Dept.
550 E. Sixth Street
Beaumont, CA 92223

NOTICE OF STREET VACATION NO. 18-SV-005

RECORDED OWNER(S)

City of Beaumont

AFFECTED ASSESSOR PARCEL NUMBER(S)

417-063-06

LEGAL DESCRIPTION

SEE ATTACHED EXHIBIT "A" AND EXHIBIT "B" ATTACHED HERETO AND MADE A PART THEREOF

SIGNATURE OF RECORD OWNER(S) (MUST BE NOTARIZED)

Signature _____
Mayor, City of Beaumont

Date _____

A notary public or other officer completing this certificate verifies only the identity of the individual who signed the document to which this certificate is attached, and not the truthfulness, accuracy, or validity of that document.

STATE OF CALIFORNIA } SS.
COUNTY OF }

ON _____ before me,

who proved to me on the basis of satisfactory evidence to be the person(s) whose name(s) is/are subscribed to the within instrument and acknowledged to me that he/she/they executed the same in his/her/their authorized capacity(ies), and that by his/her/their signature(s) on the instrument the person(s) or the entity upon behalf of which the person(s) acted, executed the instrument.

I certify under Penalty of Perjury under the laws of the State of California that the foregoing paragraph is true and correct.

WITNESS my hand and official seal.

Signature _____
Of Notary Public

See additional sheets for additional notaries needed
MAIL TAX STATEMENTS TO

DEPARTMENT USE ONLY

This Notice of Street Vacation No. 18-SV-005 is approved

By: *Robert C. Ollerton*

Title: City Surveyor

Date: 11/09/2018

SURVEY DEPARTMENT APPROVAL



EXHIBIT "A" – LEGAL DESCRIPTION
STREET VACATION NO. 18-SV-005

THAT PORTION OF LOT 5 AND LOT 6, BLOCK 9, SECTION 9, TOWNSHIP 3 SOUTH, RANGE 1 WEST, SBBM, AS PER AMENDED MAP OF THE TOWN OF BEAUMONT AS PER MAP RECORDED IN BOOK 6, PAGES 16 AND 17 OF MAPS RECORDS OF SAN BERNARDINO COUNTY, MORE PARTICULARLY DESCRIBED AS FOLLOWS:

COMMENCING AT THE SOUTHERNMOST CORNER OF LOT 6 OF SAID AMENDED MAP, SAID POINT ALSO BEING ON THE NORTHEASTERLY RIGHT-OF-WAY OF "D" STREET (NOW KNOWN AS FIFTH STREET) SHOWN ON SAID MAP;

THENCE, NORTH 57°46'36" WEST ALONG SAID NORTHEASTERLY RIGHT-OF-WAY AND ALONG THE SOUTHWESTERLY LINE OF LOT 6 A DISTANCE OF 89.93 FEET TO THE POINT OF BEGINNING, SAID POINT ALSO BEING THE BEGINNING OF A NON-TANGENT CURVE CONCAVE TO THE NORTH, SAID CURVE HAVING A RADIUS OF 90.00 FEET, A RADIAL TO SAID CURVE BEARING SOUTH 32°13'24" WEST;

THENCE, NORTHEASTERLY ALONG SAID CURVE AN ARC LENGTH OF 141.30 FEET THROUGH A CENTRAL ANGLE OF 89°57'12" TO A POINT ON THE NORTHWESTERLY RIGHT-OF-WAY OF GRACE AVENUE, SAID POINT A DISTANCE OF 14.93 FEET FROM THE NORTHEASTERLY CORNER OF LOT 6.

THENCE, SOUTH 32°16'12" WEST ALONG THE NORTHWESTERLY RIGHT-OF-WAY OF GRACE AVENUE, A DISTANCE OF 74.94 FEET TO THE BEGINNING OF A TANGENT CURVE CONCAVE TO THE NORTH, SAID CURVE HAVING A RADIUS OF 15.00 FEET.

THENCE, SOUTHWESTERLY ALONG SAID CURVE AN ARC LENGTH OF 23.55 FEET THROUGH A CENTRAL ANGLE OF 89°57'12" TO A POINT ON THE NORTHEASTERLY RIGHT-OF-WAY OF SAID "D" STREET (NOW KNOWN AS FIFTH STREET).

THENCE, NORTH 57°46'36" WEST ALONG SAID RIGHT-OF-WAY, A DISTANCE OF 74.94 FEET TO THE POINT OF BEGINNING.

EXCEPTING AND RESERVING THEREFROM AN EASEMENT FOR ANY EXISTING PUBLIC UTILITIES AND PUBLIC SERVICE FACILITIES, TOGETHER WITH THE RIGHT TO MAINTAIN, OPERATE, REPLACE, REMOVE OR RENEW SUCH FACILITIES, PURSUANT TO SECTION 8340 OF THE STREETS AND HIGHWAYS CODE.

SUBJECT TO ALL RESERVATIONS, RESTRICTION, EASEMENTS, OFFERS OF DEDICATIONS, RIGHTS AND RIGHT OF WAYS OF RECORD.

CONTAINING APPROXIMATELY 1,688 SQUARE FEET.

**THIS LEGAL DESCRIPTION WAS PREPARED BY
ME OR UNDER MY DIRECTION**

EDWARD J. BONADIMAN, PLS 9-13-18 DATE



Page 1 of 2

EXHIBIT "B" - MAP

STREET VACATION NO. 18-SV-005

SECTION 9, TOWNSHIP 3 SOUTH, RANGE 1 WEST, SBBM

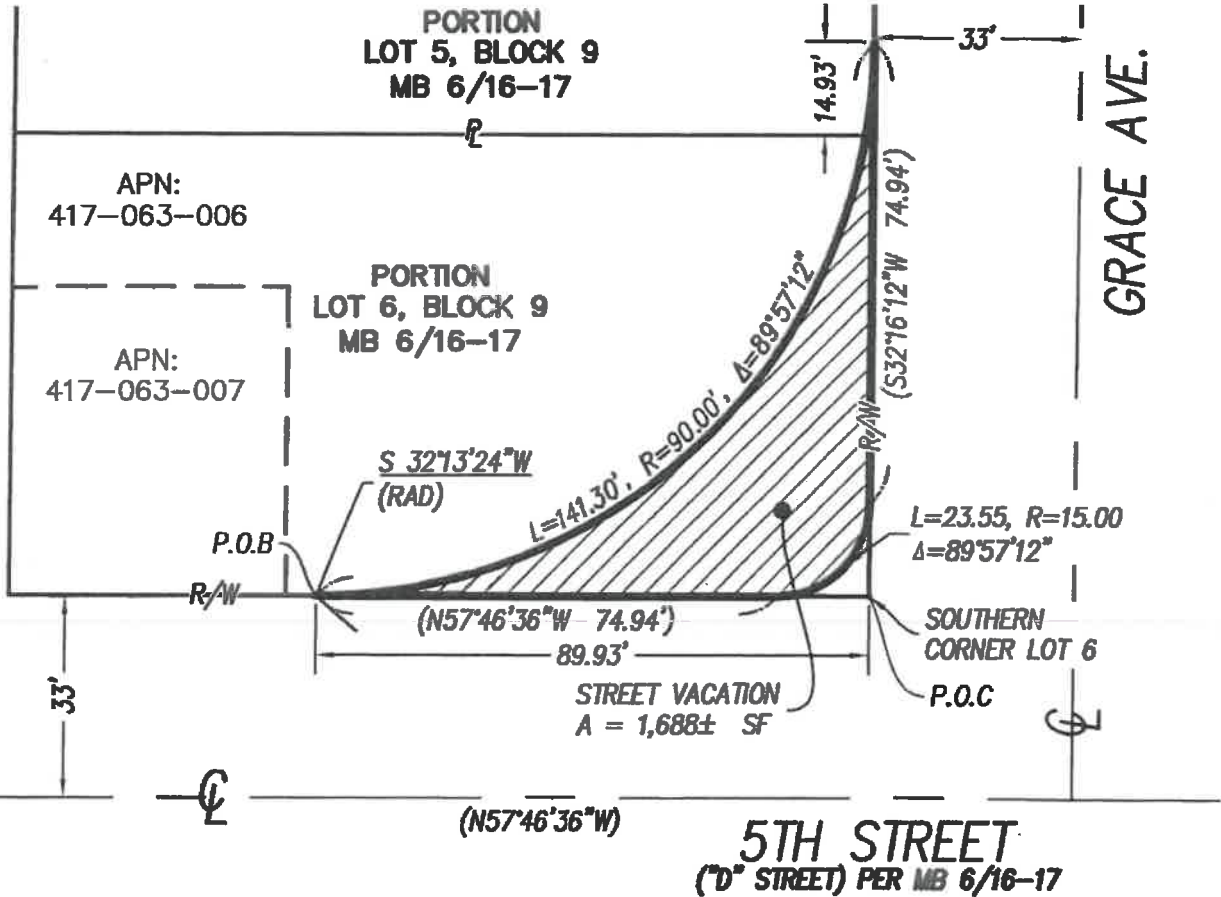
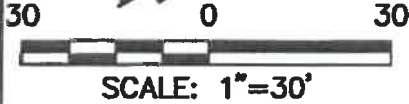

NOTE:

() REC. DATA PER MB 6/16-17



[Handwritten Signature] 9-13-18

EDWARD J. BONADIMAN DATE
EXP. 12-31-19

DRAWN BY: FA
CHECKED BY: FB
DATE: 09-13-18
JOB NO.: 184561



TEL. (909) 885-3806
234 NORTH ARROWHEAD AVE.
SAN BERNARDINO, CA 92408
FAX (909) 381-1721
www.bonadiman.com

PROJECT:
STREET VACATION
NO. 18-SV-005
APN: 417-063-006
CITY OF BEAUMONT, CA

SHT. NO.
2
OF 2

Attachment C
Street Vacation Resolution

RESOLUTION NO. _____

**A RESOLUTION OF THE CITY OF BEAUMONT AUTHORIZING
CITY COUNCIL TO SUMMARILY VACATE STREET RIGHT-OF-
WAY FROM GRACE AVENUE AND FIFTH STREET FRONTING
THE PRECISION STAMPING INCORPORATED BUILDING**

WHEREAS, Precision Stamping Incorporated requested that the City vacate approximately 1,688 square feet of street right-of-way from Grace Avenue and 5th Street fronting the Precision Stamping Building; and

WHEREAS, City agreed to vacate the street right-of-way only if the street vacation conforms to the regulations of the California Streets and Highway Code (SHC); and

WHEREAS, SHC Section 8341 requires that the legislative body determine if reservation of existing utility easements are required in the right of way that is to be vacated and in this case reservation of such existing utility easement is required; and

WHEREAS, SHC Section 8334 allows the legislative body to summarily vacate excess street right-of-way not required for street and highway purposes; and

WHEREAS, SHC Section 8336 requires the legislative body to record the resolution of vacation in the Riverside County Clerk Recorder's Office; and

WHEREAS, Staff has determined that the street vacation area of approximately 1,688 square feet from Grace Avenue and 5th Street fronting the Precision Stamping Building will not affect the City's traffic circulation element; and

NOW, THEREFORE, BE IT RESOLVED, that the City of Beaumont does authorize the street vacation of approximately 1,688 square feet from Grace Avenue and 5th Street fronting the Precision Stamping Building per the following provisions:

Provision 1. Reservation of existing public utility easements shall be kept in the street vacation area of approximately 1,688 square feet from Grace Avenue and 5th Street fronting the Precision Stamping Building

Provision 2. This resolution along with the legal description and plat for the street vacation of approximately 1,688 square feet from Grace Avenue and 5th Street fronting the Precision Stamping Building shall be recorded with the Riverside County Clerk Recorder's Office.

MOVED, PASSED AND ADOPTED this 21st day of May 2019.

AYES:

NOES:

ABSTAIN:

ABSENT:

By: _____
Julio Martinez, Mayor, City of Beaumont

ATTEST:

Steven Mehlman
CITY CLERK

By: _____

Attachment D

California Streets and Highway Code for Street Vacation



California

LEGISLATIVE INFORMATION

[Home](#)
[Bill Information](#)
[California Law](#)
[Publications](#)
[Other Resources](#)
[My Subscriptions](#)
[My Favorites](#)

 Code:

Section:

[Up^](#) [Add To My Favorites](#)

STREETS AND HIGHWAYS CODE - SHC

DIVISION 9. CHANGE OF GRADE AND VACATION [8000 - 8363] (*Division 9 added by Stats. 1941, Ch. 79.*)

PART 3. PUBLIC STREETS, HIGHWAYS, AND SERVICE EASEMENTS VACATION LAW [8300 - 8363] (*Part 3 repealed and added by Stats. 1980, Ch. 1050, Sec. 29.*)

CHAPTER 1. Short Title and Definitions [8300 - 8309] (*Chapter 1 added by Stats. 1980, Ch. 1050, Sec. 29.*)

8300. This part may be cited as the Public Streets, Highways, and Service Easements Vacation Law.
(*Repealed and added by Stats. 1980, Ch. 1050, Sec. 29.*)

8301. Unless the provision or context otherwise requires, the definitions in this chapter shall govern the construction of this part.
(*Repealed and added by Stats. 1980, Ch. 1050, Sec. 29.*)

8302. "Adoption" of a resolution includes passage or enactment of a resolution.
(*Repealed and added by Stats. 1980, Ch. 1050, Sec. 29.*)

8303. "Clerk" includes a person or officer who is the clerk of a legislative body.
(*Repealed and added by Stats. 1980, Ch. 1050, Sec. 29.*)

8304. "Legislative body" means:

- (a) In the case of a county or city and county, the board of supervisors.
 - (b) In the case of a city, the city council or other body which, by law, is the legislative body of the government of the city.
 - (c) In the case of the California Transportation Commission, the commission.
- (*Repealed and added by Stats. 1980, Ch. 1050, Sec. 29.*)

8305. "Local agency" means a county, city, or city and county.
(*Repealed and added by Stats. 1980, Ch. 1050, Sec. 29.*)

8305.5. "Public entity" means a local agency or the California Transportation Commission.
(*Added by Stats. 1980, Ch. 1050, Sec. 29.*)

8306. "Public service easement" includes all or part of, or any right in:

- (a) A right-of-way, easement, or use restriction acquired for public use by dedication or otherwise for sewers, pipelines, poeelines, electrical transmission and communication lines, pathways, storm drains, drainage, canal, water transmission lines, light and air, and other limited use public easements other than for street or highway purposes.
 - (b) An easement or right of a type described in Section 8340.
- (*Repealed and added by Stats. 1980, Ch. 1050, Sec. 29.*)

8306.5. "Public utility" means a public utility as defined in Section 216 of the Public Utilities Code.
(*Added by Stats. 1980, Ch. 1050, Sec. 29.*)

8307. "Resolution" includes an ordinance.

(Repealed and added by Stats. 1980, Ch. 1050, Sec. 29.)

8308. "Street" and "highway" include all or part of, or any right in, a state highway or other public highway, road, street, avenue, alley, lane, driveway, place, court, trail, or other public right-of-way or easement, or purported public street or highway, and rights connected therewith, including, but not limited to, restrictions of access or abutters' rights, sloping easements, or other incidents to a street or highway.

(Repealed and added by Stats. 1980, Ch. 1050, Sec. 29.)

8309. "Vacation" means the complete or partial abandonment or termination of the public right to use a street, highway, or public service easement.

(Added by Stats. 1980, Ch. 1050, Sec. 29.)



California

LEGISLATIVE INFORMATION

[Home](#)
[Bill Information](#)
[California Law](#)
[Publications](#)
[Other Resources](#)
[My Subscriptions](#)
[My Favorites](#)

 Code:

Section:

[Up^](#) [Add To My Favorites](#)

STREETS AND HIGHWAYS CODE - SHC

DIVISION 9. CHANGE OF GRADE AND VACATION [8000 - 8363] (*Division 9 added by Stats. 1941, Ch. 79.*)

PART 3. PUBLIC STREETS, HIGHWAYS, AND SERVICE EASEMENTS VACATION LAW [8300 - 8363] (*Part 3 repealed and added by Stats. 1980, Ch. 1050, Sec. 29.*)

CHAPTER 2. General Provisions [8310 - 8317] (*Chapter 2 added by Stats. 1980, Ch. 1050, Sec. 29.*)

8310. This part shall be liberally construed in order to effectuate its purposes.
(*Added by Stats. 1980, Ch. 1050, Sec. 29.*)

8311. (a) The procedures provided in this part are alternative procedures for vacating streets, highways, and public service easements. The authority granted in this part is an alternative to any other authority provided by law to public entities.

(b) The provisions of this part shall not apply to or affect any other provision of this code. If proceedings are commenced under this part, the provisions of this part, and no other provisions of this code, shall apply to the proceedings.

(*Added by Stats. 1980, Ch. 1050, Sec. 29.*)

8312. Except as provided in Section 8315, a city legislative body may vacate, pursuant to this part, all or part of a street, highway, or public service easement within the city and a board of supervisors may vacate all or part of a street, highway, or public service easement within the county but outside a city.

(*Added by Stats. 1980, Ch. 1050, Sec. 29.*)

8313. (a) If the proposed vacation of a street, highway, or public service easement is within an area for which a general plan is adopted by a local agency, the legislative body of the public entity shall consider the general plan prior to vacating the street, highway, or public service easement.

(b) The procedure prescribed in Section 65402 of the Government Code shall be followed if that section applies to the proposed vacation. If Section 65402 of the Government Code does not apply to the proposed vacation, the legislative body may submit the proposed vacation to the local planning commission or planning agency and give the commission or agency an opportunity to report upon the proposed vacation.

(*Amended by Stats. 1986, Ch. 982, Sec. 31.*)

8314. Section 892 applies to a street, highway, or public service easement vacated pursuant to this part.

(*Amended by Stats. 2000, Ch. 787, Sec. 15. Effective January 1, 2001.*)

8315. A state highway may be vacated under this part only by the commission.

(*Added by Stats. 1980, Ch. 1050, Sec. 29.*)

8316. One or more streets, highways, and public service easements, whether or not contiguous, may be included and vacated in the same proceeding.

(*Added by Stats. 1980, Ch. 1050, Sec. 29.*)

8317. (a) Proof of publication of a notice shall be made by affidavit pursuant to the Code of Civil Procedure. Proof of the posting of a notice shall be made by affidavit of the person posting it, reciting the facts of the posting.

(b) An officer required to have any notice published or posted shall file the affidavit in his or her office. Failure to do so does not invalidate proceedings under this part. An affidavit so filed is prima facie evidence of the facts stated in it.

(Added by Stats. 1980, Ch. 1050, Sec. 29.)

[Home](#)
[Bill Information](#)
[California Law](#)
[Publications](#)
[Other Resources](#)
[My Subscriptions](#)
[My Favorites](#)

 Code:

Section:

[Up^](#) [Add To My Favorites](#)
STREETS AND HIGHWAYS CODE - SHC
DIVISION 9. CHANGE OF GRADE AND VACATION [8000 - 8363] (*Division 9 added by Stats. 1941, Ch. 79.*)

PART 3. PUBLIC STREETS, HIGHWAYS, AND SERVICE EASEMENTS VACATION LAW [8300 - 8363] (*Part 3 repealed and added by Stats. 1980, Ch. 1050, Sec. 29.*)

CHAPTER 3. General Vacation Procedure [8320 - 8325] (*Chapter 3 added by Stats. 1980, Ch. 1050, Sec. 29.*)

8320. (a) The legislative body of a local agency may initiate a proceeding under this chapter in either of the following ways:

- (1) On its own initiative, where the clerk of the legislative body shall administratively set a hearing by fixing the date, hour, and place of the hearing and cause the publishing and posting of the notices required by this chapter.
- (2) Upon a petition or request of an interested person, at the discretion of the legislative body, except as provided in subdivision (e) of Section 8321, where the clerk of the legislative body shall administratively set a hearing by fixing the date, hour, and place of the hearing and cause the publishing and posting of the notices required by this chapter.

(b) The notices required by this chapter shall contain both of the following:

- (1) A description of the street, highway, or public service easement proposed to be vacated and a reference to a map or plan, that shows the portion or area to be vacated and includes a statement that the vacation proceeding is conducted under this chapter. In the case of a street or highway, the description shall include its general location, its lawful or official name or the name by which it is commonly known, and the extent to which it is to be vacated. In the case of a public service easement, the description shall identify it with common certainty. The map or plan showing the location of the street, highway, or public easement proposed to be vacated is sufficient compliance with this paragraph.
- (2) The date, hour, and place for hearing all persons interested in the proposed vacation. The date shall not be less than 15 days after the initiation of proceedings.

(Amended by Stats. 1998, Ch. 876, Sec. 20. Effective January 1, 1999.)

8321. (a) Ten or more freeholders may petition the board of supervisors to vacate a street or highway under this chapter. At least two of the petitioners shall be residents of the road district in which some part of the street or highway proposed to be vacated is situated and shall be taxable therein for street or highway purposes.

(b) Five or more freeholders may petition the board of supervisors to vacate a public service easement under this chapter. At least one of the petitioners shall be a resident of the township in which the public service easement proposed to be vacated is situated.

(c) The residence address of each petitioner shall be set forth in the petition.

(d) The board of supervisors may require the payment of a fee for filing a petition to defray the expenses of investigations, mailings, publications, and postings under this chapter.

(e) Upon the filing of a petition and the making of the deposit, if any, required under this section, the board of supervisors, by order, shall fix the date, hour, and place of the hearing on the petition. At least two weeks before the day set for the hearing, the clerk of the board shall mail a notice of the date, hour, and place of the hearing to each of the petitioners at the address set forth in the petition.

(f) Nothing in this section shall affect the right of a legislative body to initiate a proceeding under this chapter upon its own initiative, or upon petition or request of an interested person, or prevent the board of supervisors from vacating a street, highway, or public service easement without charging costs if the board determines it is in the public interest to do so.

(Amended by Stats. 1981, Ch. 64, Sec. 1.)

8322. (a) Except as provided in subdivisions (b) and (c), notice of the hearing on the proposed vacation shall be published for at least two successive weeks prior to the hearing in a daily, semiweekly, or weekly newspaper published and circulated in the local agency conducting the proceeding and which is selected by the legislative body for that purpose or by the clerk or other officer responsible for the publication where the legislative body has not selected any newspaper for that purpose.

(b) If the proceeding is conducted by a city and there is no daily, semiweekly, or weekly newspaper published and circulated in the city, the notice shall be published in some newspaper published in the county in which the city is located.

(c) Notice need not be published under this section where there is no daily, semiweekly, or weekly newspaper published and circulating in the county in which the local agency conducting the proceeding is located.

(Amended by Stats. 1998, Ch. 876, Sec. 21. Effective January 1, 1999.)

8323. At least two weeks before the day set for the hearing, the legislative body shall post conspicuously notices of vacation along the line of the street, highway, or public service easement proposed to be vacated. The notices shall be posted not more than 300 feet apart, but at least three notices shall be posted. If the line of the street, highway, or public service easement proposed to be vacated exceeds one mile in length, the legislative body may, in lieu of posting not more than 300 feet apart, post notices at each intersection of another street or highway with the street, highway, or public service easement to be vacated and at one point approximately midway between each intersection, but at least three notices shall be posted.

(Amended by Stats. 1998, Ch. 876, Sec. 22. Effective January 1, 1999.)

8324. (a) At the hearing, the legislative body shall hear the evidence offered by persons interested.

(b) If the legislative body finds, from all the evidence submitted, that the street, highway, or public service easement described in the notice of hearing or petition is unnecessary for present or prospective public use, the legislative body may adopt a resolution vacating the street, highway, or public service easement. The resolution of vacation may provide that the vacation occurs only after conditions required by the legislative body have been satisfied and may instruct the clerk that the resolution of vacation not be recorded until the conditions have been satisfied.

(Amended by Stats. 1998, Ch. 876, Sec. 23. Effective January 1, 1999.)

8325. (a) The clerk shall cause a certified copy of the resolution of vacation, attested by the clerk under seal, to be recorded without acknowledgment, certificate of acknowledgment, or further proof in the office of the recorder of the county in which the property is located. No fee shall be charged for recordation.

(b) Upon such recordation, the vacation is complete.

(Added by Stats. 1980, Ch. 1050, Sec. 29.)



California LEGISLATIVE INFORMATION

[Home](#)
[Bill Information](#)
[California Law](#)
[Publications](#)
[Other Resources](#)
[My Subscriptions](#)
[My Favorites](#)

 Code:

 Section:

[Up^](#) [Add To My Favorites](#)

STREETS AND HIGHWAYS CODE - SHC

DIVISION 9. CHANGE OF GRADE AND VACATION [8000 - 8363] (*Division 9 added by Stats. 1941, Ch. 79.*)

PART 3. PUBLIC STREETS, HIGHWAYS, AND SERVICE EASEMENTS VACATION LAW [8300 - 8363] (*Part 3 repealed and added by Stats. 1980, Ch. 1050, Sec. 29.*)

CHAPTER 4. Summary Vacation [8330 - 8336] (*Chapter 4 added by Stats. 1980, Ch. 1050, Sec. 29.*)

ARTICLE 1. Authority [8330 - 8334.5] (*Article 1 added by Stats. 1980, Ch. 1050, Sec. 29.*)

8330. (a) The legislative body of a local agency may summarily vacate a street or highway that has been superseded by relocation.

(b) A street or highway shall not be summarily vacated pursuant to this section if vacation would do either of the following:

- (1) Cut off all access to a person's property which, prior to relocation, adjoined the street or highway.
 - (2) Terminate a public service easement, unless the easement satisfies the requirements of Section 8333.
- (*Repealed and added by Stats. 1980, Ch. 1050, Sec. 29.*)

8330.5. (a) Subject to subdivisions (b) and (c), the commission may retain, relinquish to a local agency pursuant to Section 73, or summarily vacate a state highway that has been superseded by relocation.

(b) The commission shall not vacate a state highway unless the commission has first given a notice of relinquishment pursuant to Section 73 and the legislative body of the local agency has protested within the prescribed 90-day period that the highway is not needed for public use and should be vacated by the commission.

(c) If vacation of a state highway would cut off all access to the property of any person which, prior to relocation, adjoined the highway, the commission shall either retain the highway or relinquish it pursuant to Section 73.

(*Added by Stats. 1980, Ch. 1050, Sec. 29.*)

8331. The legislative body of a local agency may summarily vacate a street or highway if both of the following conditions exist:

- (a) For a period of five consecutive years, the street or highway has been impassable for vehicular travel.
- (b) No public money was expended for maintenance on the street or highway during such period.

(*Repealed and added by Stats. 1980, Ch. 1050, Sec. 29.*)

8332. The legislative body of a local agency may summarily vacate a street or highway pursuant to an agreement entered into with the department pursuant to Section 100.2 to close the street or highway at or near the point of its interception with a state freeway.

(*Repealed and added by Stats. 1980, Ch. 1050, Sec. 29.*)

8333. The legislative body of a local agency, or any public officer or employee authorized by the legislative body as provided in subdivision (a) of Section 8335, may summarily vacate a public service easement in any of the following cases:

- (a) The easement has not been used for the purpose for which it was dedicated or acquired for five consecutive years immediately preceding the proposed vacation.
- (b) The date of dedication or acquisition is less than five years, and more than one year, immediately preceding the proposed vacation, and the easement was not used continuously since that date.

(c) The easement has been superseded by relocation, or determined to be excess by the easement holder, and there are no other public facilities located within the easement.

(Amended by Stats. 2015, Ch. 269, Sec. 35. (SB 184) Effective January 1, 2016.)

8334. The legislative body of a local agency may summarily vacate any of the following:

(a) An excess right-of-way of a street or highway not required for street or highway purposes.

(b) A portion of a street or highway that lies within property under one ownership and that does not continue through such ownership or end touching property of another.

(Added by Stats. 1980, Ch. 1050, Sec. 29.)

8334.5. Notwithstanding any other provision of this article, a street, highway, or public service easement may not be summarily vacated if there are in-place public utility facilities that are in use and would be affected by the vacation.

(Added by Stats. 1980, Ch. 1050, Sec. 29.)



California LEGISLATIVE INFORMATION

[Home](#)
[Bill Information](#)
[California Law](#)
[Publications](#)
[Other Resources](#)
[My Subscriptions](#)
[My Favorites](#)
Code: Section:

[Up^](#) [Add To My Favorites](#)
STREETS AND HIGHWAYS CODE - SHC
DIVISION 9. CHANGE OF GRADE AND VACATION [8000 - 8363] *(Division 9 added by Stats. 1941, Ch. 79.)*
PART 3. PUBLIC STREETS, HIGHWAYS, AND SERVICE EASEMENTS VACATION LAW [8300 - 8363] *(Part 3 repealed and added by Stats. 1980, Ch. 1050, Sec. 29.)*
CHAPTER 4. Summary Vacation [8330 - 8336] *(Chapter 4 added by Stats. 1980, Ch. 1050, Sec. 29.)*
ARTICLE 2. Procedure [8335 - 8336] *(Article 2 added by Stats. 1980, Ch. 1050, Sec. 29.)*

8335. (a) (1) The legislative body may vacate a street, highway, or public service easement pursuant to the authority provided in this chapter by adopting a resolution of vacation.

(2) The legislative body may delegate the authority to vacate a public service easement to any public officer or employee otherwise qualified to prepare easements or approve parcel maps or final maps as defined in Title 7 of Division 2 of the Government Code, pursuant to the authority provided in this chapter by recordation of a document containing the information in subdivision (b).

(b) The resolution of vacation shall state all of the following:

(1) That the vacation is made under this chapter.

(2) The name or other designation of the street, highway, or public service easement and a precise description of the portion vacated. The description of the portion vacated may be by a precise map which is recorded or to which reference is made in the resolution and which is permanently maintained by the public entity.

(3) The facts under which the summary vacation is made. If the vacation is made pursuant to Section 8332, the statement shall include the date of the agreement. The resolution is prima facie evidence of the facts stated.

(4) That from and after the date the resolution is recorded, the street, highway, or public service easement vacated no longer constitutes a street, highway, or public service easement.

(5) If the resolution of vacation applies to a public service easement vacated by a public officer or employee delegated authority pursuant to subdivision (a), a certification that all entities having any right, title, or interest in the public service easement being vacated have been notified of this action.

(Amended by Stats. 2015, Ch. 269, Sec. 36. (SB 184) Effective January 1, 2016.)

8336. (a) The clerk shall cause a certified copy of the resolution of vacation, attested by the clerk under seal, to be recorded without acknowledgment, certificate of acknowledgment, or further proof in the office of the recorder of the county in which the property is located. No fee shall be charged for recordation.

(b) Upon such recordation, the vacation is complete.

(Added by Stats. 1980, Ch. 1050, Sec. 29.)

[Home](#)
[Bill Information](#)
[California Law](#)
[Publications](#)
[Other Resources](#)
[My Subscriptions](#)
[My Favorites](#)
Code: Section:

[Up^](#)
[<< Previous](#)
[Next >>](#)
[cross-reference chartered bills](#)
[PDF](#)
[Add To My Favorites](#)

STREETS AND HIGHWAYS CODE - SHC

DIVISION 9. CHANGE OF GRADE AND VACATION [8000 - 8363] (*Division 9 added by Stats. 1941, Ch. 79.*)

PART 3. PUBLIC STREETS, HIGHWAYS, AND SERVICE EASEMENTS VACATION LAW [8300 - 8363] (*Part 3 repealed and added by Stats. 1980, Ch. 1050, Sec. 29.*)

CHAPTER 5. Reservation and Preservation of Easements [8340 - 8349] (*Chapter 5 added by Stats. 1980, Ch. 1050, Sec. 29.*)

ARTICLE 1. Reservation of Easements [8340 - 8341] (*Article 1 added by Stats. 1980, Ch. 1050, Sec. 29.*)

8341. (a) In a proceeding to vacate a street or highway, if the legislative body determines that the public convenience and necessity require the reservation and exception of easements and rights-of-way for works enumerated in Section 8340, such reservations and exceptions shall be recited in the resolution of vacation, in addition to any other matter required to be recited therein. The recital may describe the reservations and exceptions by reference to a precise map which is recorded or to which reference is made in the resolution and which is permanently maintained by the public entity.

(b) Subsequent proceedings of the public entity in relation to the vacation, including a deed or conveyance of title to or an interest in the property, are subject to, and governed by, the reservations and exceptions recited in the resolution of vacation and the deed or conveyance shall contain a recital to that effect.

(*Added by Stats. 1980, Ch. 1050, Sec. 29.*)

Attachment E

Utility Purveyor Street Vacation Notice



February 8, 2019

All Utility Purveyors within City of Beaumont

SUBJECT: UTILITY NOTICE- Street Vacation on 5th Street and Grace Avenue Fronting the Precision Stamping Building

The City of Beaumont is planning to vacate approximately 1,688 square feet on 5th Street and Grace Avenue fronting the Precision Stamping Building. Prior to processing the street vacation, the City wants to verify with all utility purveyors if their utility will at all be affected by the street vacation. Along with the proposed street vacation, reservation of existing public utility easements will be kept allowing utility purveyors to operate and maintain their utility.

Attachment A contains a depiction of the proposed street vacation. Please review the attachment and confirm if your respective utility will or will not be affected by the proposed street vacation.

Sincerely,

Gull Nawaz
Assistant Engineer

Attachments

Attachment A – Exhibit of Proposed Street Vacation

Attachment A

Exhibit of Proposed Street Vacation

EXHIBIT "A" – LEGAL DESCRIPTION
STREET VACATION NO. 18-SV-005

THAT PORTION OF LOT 5 AND LOT 6, BLOCK 9, SECTION 9, TOWNSHIP 3 SOUTH, RANGE 1 WEST, SBBM, AS PER AMENDED MAP OF THE TOWN OF BEAUMONT AS PER MAP RECORDED IN BOOK 6, PAGES 16 AND 17 OF MAPS RECORDS OF SAN BERNARDINO COUNTY, MORE PARTICULARLY DESCRIBED AS FOLLOWS:

COMMENCING AT THE SOUTHERNMOST CORNER OF LOT 6 OF SAID AMENDED MAP, SAID POINT ALSO BEING ON THE NORTHEASTERLY RIGHT-OF-WAY OF "D" STREET (NOW KNOWN AS FIFTH STREET) SHOWN ON SAID MAP;

THENCE, NORTH 57°46'36" WEST ALONG SAID NORTHEASTERLY RIGHT-OF-WAY AND ALONG THE SOUTHWESTERLY LINE OF LOT 6 A DISTANCE OF 89.93 FEET TO THE POINT OF BEGINNING, SAID POINT ALSO BEING THE BEGINNING OF A NON-TANGENT CURVE CONCAVE TO THE NORTH, SAID CURVE HAVING A RADIUS OF 90.00 FEET, A RADIAL TO SAID CURVE BEARING SOUTH 32°13'24" WEST;

THENCE, NORTHEASTERLY ALONG SAID CURVE AN ARC LENGTH OF 141.30 FEET THROUGH A CENTRAL ANGLE OF 89°57'12" TO A POINT ON THE NORTHWESTERLY RIGHT-OF-WAY OF GRACE AVENUE, SAID POINT A DISTANCE OF 14.93 FEET FROM THE NORTHEASTERLY CORNER OF LOT 6.

THENCE, SOUTH 32°16'12" WEST ALONG THE NORTHWESTERLY RIGHT-OF-WAY OF GRACE AVENUE, A DISTANCE OF 74.94 FEET TO THE BEGINNING OF A TANGENT CURVE CONCAVE TO THE NORTH, SAID CURVE HAVING A RADIUS OF 15.00 FEET.

THENCE, SOUTHWESTERLY ALONG SAID CURVE AN ARC LENGTH OF 23.55 FEET THROUGH A CENTRAL ANGLE OF 89°57'12" TO A POINT ON THE NORTHEASTERLY RIGHT-OF-WAY OF SAID "D" STREET (NOW KNOWN AS FIFTH STREET).

THENCE, NORTH 57°46'36" WEST ALONG SAID RIGHT-OF-WAY, A DISTANCE OF 74.94 FEET TO THE POINT OF BEGINNING.

EXCEPTING AND RESERVING THEREFROM AN EASEMENT FOR ANY EXISTING PUBLIC UTILITIES AND PUBLIC SERVICE FACILITIES, TOGETHER WITH THE RIGHT TO MAINTAIN, OPERATE, REPLACE, REMOVE OR RENEW SUCH FACILITIES, PURSUANT TO SECTION 8340 OF THE STREETS AND HIGHWAYS CODE.

SUBJECT TO ALL RESERVATIONS, RESTRICTION, EASEMENTS, OFFERS OF DEDICATIONS, RIGHTS AND RIGHT OF WAYS OF RECORD.

CONTAINING APPROXIMATELY 1,688 SQUARE FEET.

**THIS LEGAL DESCRIPTION WAS PREPARED BY
ME OR UNDER MY DIRECTION**

EDWARD J. BONADIMAN, PLS 9-13-18 DATE



Page 1 of 2

EXHIBIT "B" - MAP

STREET VACATION NO. 18-SV-005

SECTION 9, TOWNSHIP 3 SOUTH, RANGE 1 WEST, SBBM

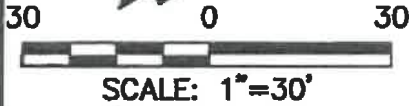

SCALE: 1"=30'

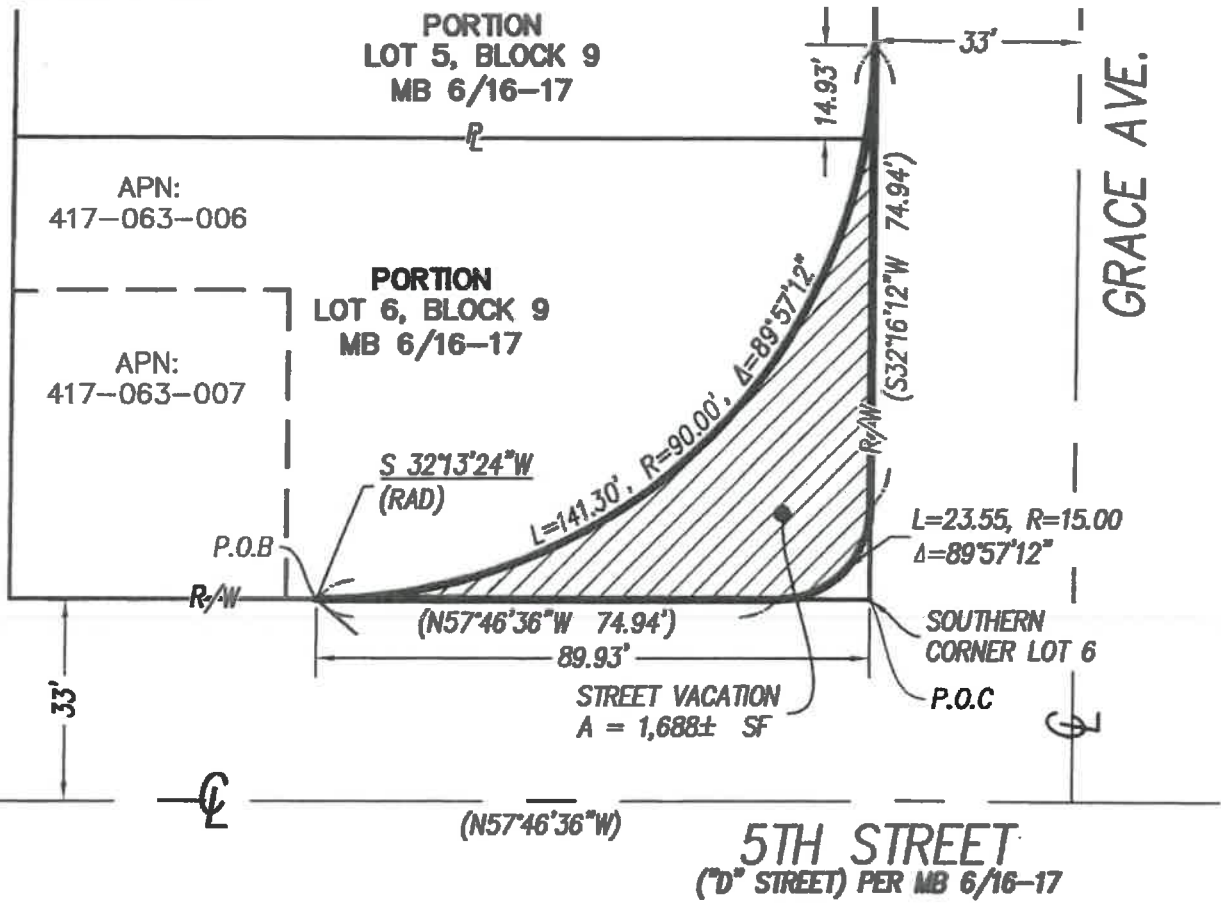

NOTE:

() REC. DATA PER MB 6/16-17

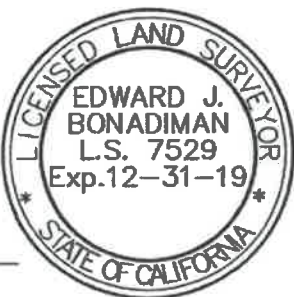

Edward J. Bonadiman
 EDWARD J. BONADIMAN
 EXP. 12-31-19

9-13-18
 DATE

DRAWN BY: FA		TEL. (909) 885-3806	PROJECT:
CHECKED BY: EB		234 NORTH ARROWHEAD AVE. SAN BERNARDINO, CA 92408	STREET VACATION
DATE: 09-13-18		FAX (909) 381-1721 www.bonadiman.com	NO. 18-SV-005
JOB NO.: 184561		JOSEPH E. BONADIMAN & ASSOCIATES, INC. ENGINEERS • S.I.S. • SURVEYING • PLANNING	APN: 417-063-006
			2
			OF 2

EXHIBIT "B" - MAP

STREET VACATION NO. 18-SV-005

SECTION 9, TOWNSHIP 3 SOUTH, RANGE 1 WEST, SBBM

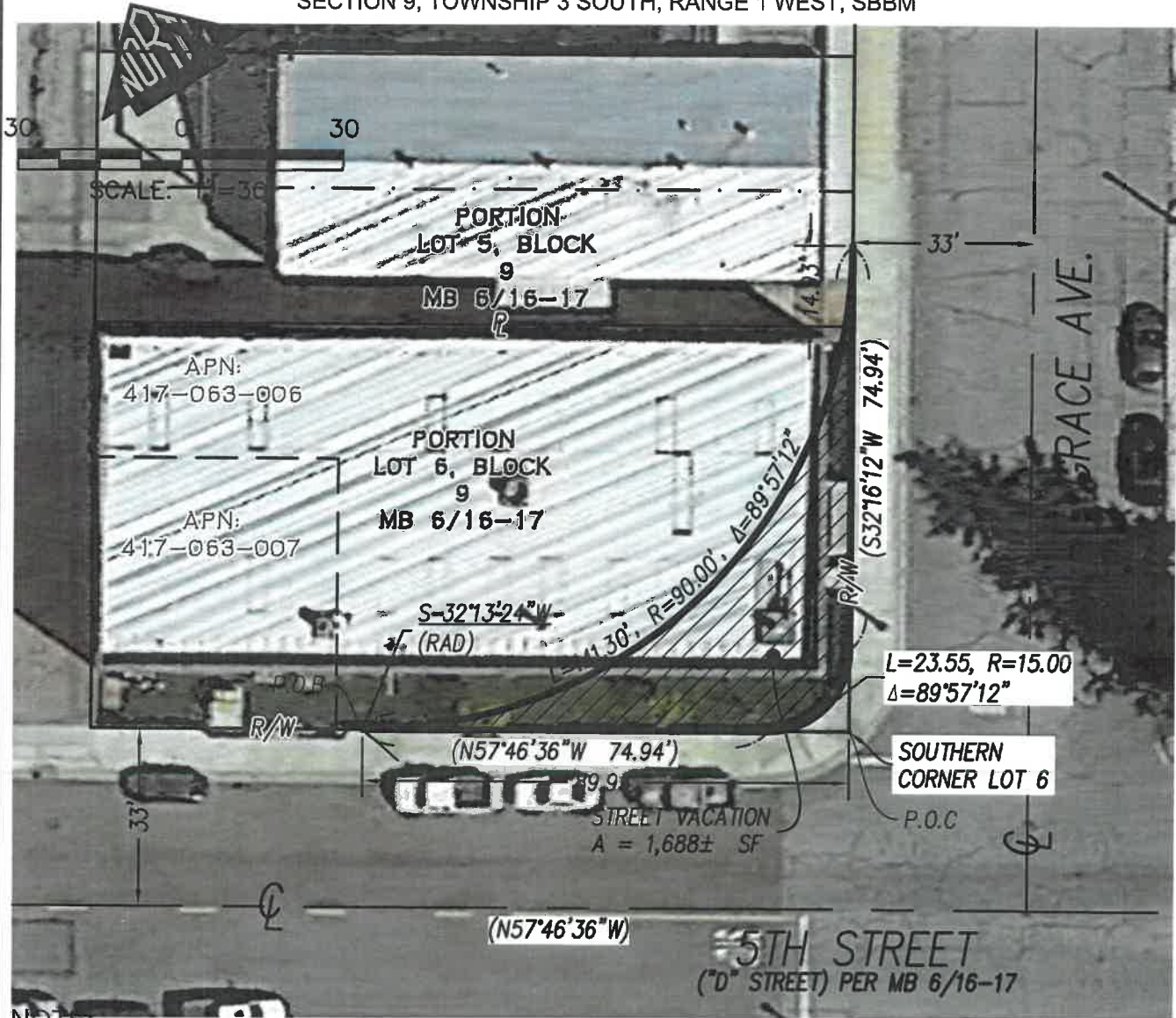

EDWARD J. BONADIMAN _____ DATE _____
EXP. 12-31-19

DRAWN BY: FA CHECKED BY: EB DATE: 09-13-18 JOB NO.: 184561	BONADIMAN <small>JOSEPH E. BONADIMAN & ASSOCIATES, INC. ENGINEERS • G.I.S. • SURVEYING • PLANNING</small>	TEL. (909) 885-3806 234 NORTH ARROWHEAD AVE. SAN BERNARDINO, CA 92408 FAX (909) 381-1721 www.bonadiman.com	PROJECT: STREET VACATION NO. 18-SV-005 APN: 417-063-006 CITY OF BEAUMONT, CA	SHT. NO. 2 OF 2
---	---	--	--	---

Attachment F

Utility Purveyor Responses to Proposed Street Vacation

Gull Nawaz

From: Cole R Wright <cole.wright@dominionenergy.com>
Sent: Wednesday, February 13, 2019 10:04 AM
To: Gull Nawaz
Cc: Kevin Norville
Subject: RE: Street Vacation - Questar
Attachments: Utility Notice - Street Vacation.pdf

Gull,

I have reviewed the attached utility information request. Questar Southern Trails does not have facilities within the project boundaries indicated in the attached documents.

Please let me know if there is anything else you require. Thank you for your time.

Cole Wright, P.E.
Engineer III
Operations Engineering



Dominion Energy Questar Pipeline Services, Inc.
1005 D Street, Rock Springs, WY 82901
O: (307) 352-7115 C: (801) 647-1971

CONFIDENTIALITY NOTICE: This electronic message contains information which may be legally confidential and/or privileged and does not in any case represent a firm ENERGY COMMODITY bid or offer relating thereto which binds the sender without an additional express written confirmation to that effect. The information is intended solely for the individual or entity named above and access by anyone else is unauthorized. If you are not the intended recipient, any disclosure, copying, distribution, or use of the contents of this information is prohibited and may be unlawful. If you have received this electronic transmission in error, please reply immediately to the sender that you have received the message in error, and delete it. Thank you

From: Gull Nawaz <gnawaz@beaumontca.gov>
Sent: Friday, February 08, 2019 10:33 AM
To: Cole R Wright (GasInfrastructure - 2) <cole.wright@dominionenergy.com>
Cc: Kevin Norville <KNorville@beaumontca.gov>
Subject: [External] Street Vacation - Questar

Hi Cole,

The City of Beaumont is planning to vacate approximately 1,688 square feet on 5th Street and Grace Avenue fronting the Precision Stamping building in the City of Beaumont. Attached is the utility notice and the depiction of the proposed street vacation. Please confirm if Questar's utility will or will not be affected by the proposed street vacation.

Thank You,



Southern California Gas Company
1981 W. Lugonia Avenue
Redlands, CA 92374-9720

Mailing Address:
PO Box 3003, SC8031
Redlands, CA 92373-0306

April 8, 2019

Gas Company Ref.: RCO 1959

City of Beaumont
550 E. 6th Street
Beaumont, CA 92223

**Subject: Street Vacation on 5th Street and Grace Avenue Fronting
The Precision Stamping Building**

Southern California Gas Company has no facilities in the proposed vacation area and, therefore, does not require an easement reservation.

When the resolution and/or ordinance have been recorded, please send a copy to us so that we may update our records and mapping

Should you need further information, please contact me at (909) 335-7733.

Sincerely,

Gertman G. Thomas
Southern California Gas Company
1981 W. Lugonia Ave.
Redlands, CA 92374

Gull Nawaz

From: Melissa Martin <Melissa.Martin@sce.com>
Sent: Wednesday, February 27, 2019 9:38 AM
To: Gull Nawaz
Subject: FW: (External):RE: Street Vacation - SCE

Hi Gull,

There is not transmission in this area. David Salmon is the distribution planner for this area. I did send your email to him when Monica first provided it. David should be in contact with you. His cell 951 -201-1990.

I am the agent who would assist with any real property issues dealing with transmission facilities in Beaumont. Please keep my information in case you ever need help with anything.

Thank you,

Melissa Martin
Land Services Agent 4
Eastern Region Land Management - Real Properties
T. 909-820-5316 | M. 626-862-9996
300 N. Pepper Avenue, Bldg. C, Rialto, CA 92376



SOUTHERN CALIFORNIA
EDISON

Energy for What's Ahead™

From: Gull Nawaz [<mailto:gnawaz@beaumontca.gov>]
Sent: Tuesday, February 26, 2019 3:39 PM
To: Monica 3 Contreras <Monica.3.Contreras@sce.com>
Cc: Kevin Norville <KNorville@beaumontca.gov>
Subject: (External):RE: Street Vacation - SCE

Hi Monica,

Has Edison reviewed the proposed street vacation? I know you had mentioned that someone from a different department will be responding after reviewing the street vacation.

GULL NAWAZ
Assistant Engineer

City of Beaumont
550 E. 6th Street, Beaumont, Ca 92223
Desk (951) 769-8520 Ext. 358
BeaumontCa.gov
Facebook | Twitter | Instagram | YouTube

BEAUMONT CHERRY VALLEY WATER DISTRICT

560 Magnolia Avenue

Beaumont, CA 92223

(951)-845-9581

MEMORANDUM

February 12, 2019

TO: Gull Nawaz
Assistant Engineer

FROM: Mark Swanson
Senior Engineer

SUBJECT: Utility Notice – 5th Street & Grace Avenue Fronting the Precision Stamping Building

Notice was provided to Beaumont Cherry Valley Water District by the City of Beaumont on February 8, 2019 regarding the City's desire to vacate approximately 1,688 square feet of existing right of way on the northwest corner of 5th Street and Grace Avenue and for Beaumont Cherry Valley Water District to determine if their utility would be affected by the proposed street vacation.

The District has reviewed its GIS system and conducted a field walk of the subject location and has determined that there are **NO EXISTING FACILITIES** owned and operated by Beaumont Cherry Valley Water District located within the proposed vacation area.

Attachment – Exhibit of Proposed Street Vacation

Gull Nawaz

From: Coley, Keith L <Keith.Coley@charter.com>
Sent: Thursday, February 21, 2019 7:20 AM
To: Gull Nawaz
Subject: RE: Street Vacation - Spectrum

Charter: Do not have known cable lines on 5th and Grace ave in Beaumont



Keith Coley | Construction Coordinator
O: 951.406.1631 | C: 909-821-8024
7337 Central Ave | Riverside, CA 92504

From: Gull Nawaz [mailto:gnawaz@beaumontca.gov]
Sent: Friday, February 08, 2019 9:27 AM
To: Coley, Keith L <Keith.Coley@charter.com>
Cc: Kevin Norville <KNorville@beaumontca.gov>
Subject: Street Vacation - Spectrum

Hi Keith,

The City of Beaumont is planning to vacate approximately 1,688 square feet on 5th Street and Grace Avenue fronting the Precision Stamping building in the City of Beaumont. Attached is the utility notice and the depiction of the proposed street vacation. Please confirm if Spectrum's utility will or will not be affected by the proposed street vacation.

Thank You,

Gull Nawaz
Assistant Engineer
City of Beaumont
550 E. 6th Street
Beaumont, CA 92223
(951) 769-8520 ext. 358



The contents of this e-mail message and any attachments are intended solely for the

Frontier

MAPS ARE NOT TO SCALE

CONDUIT FACILITIES
COPPER FACILITIES
FIBER FACILITIES
PROPOSED FACILITIES
LOT LINES
STREET CENTER LINE
JOINT POLES
FRONTIER POLES
CALL 811 FOR LOOK UP

← N ↑

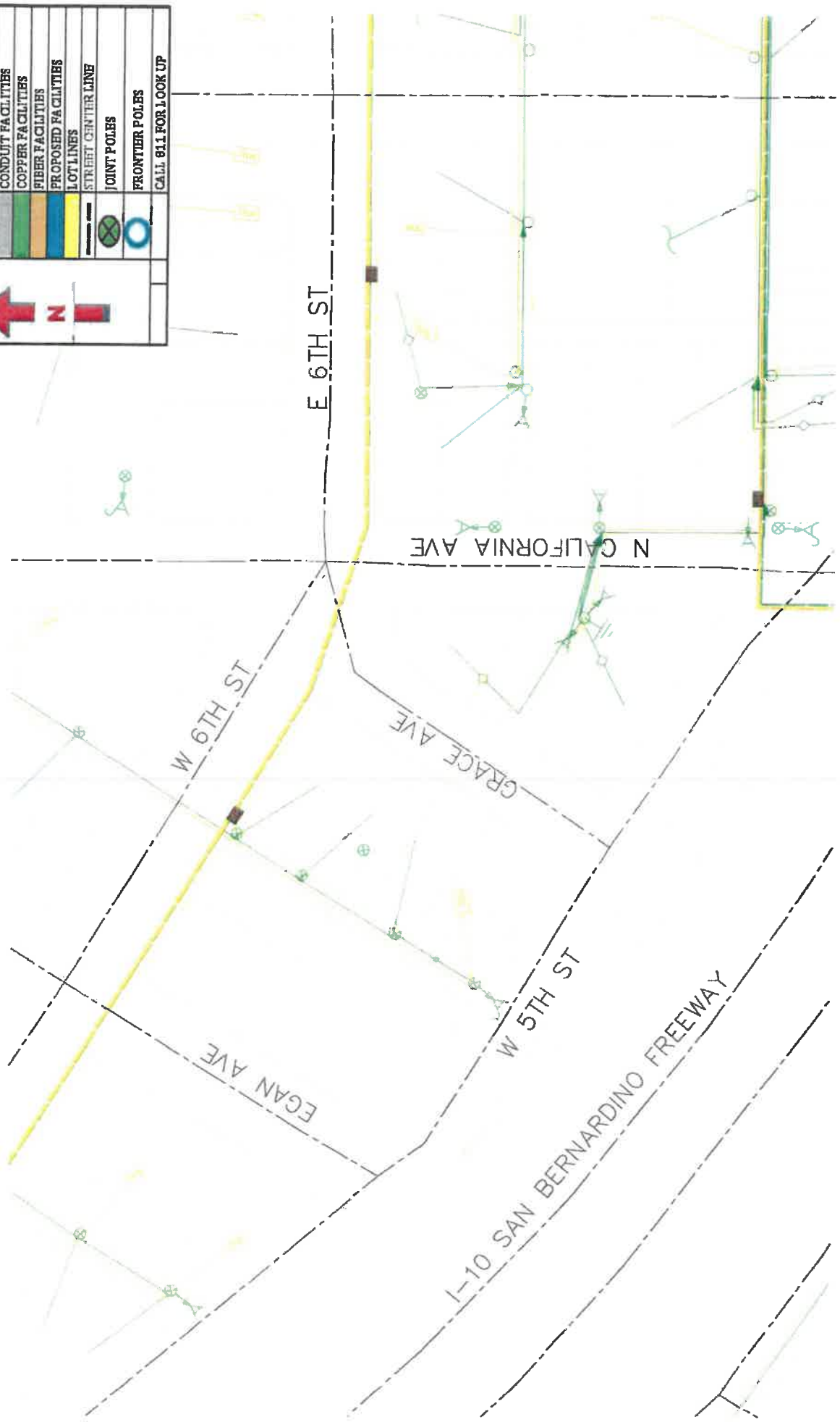

Gull Nawaz

From: PipelineInquiries <PipelineInquiries@kindermorgan.com>
Sent: Monday, February 18, 2019 11:19 AM
To: Gull Nawaz
Subject: RE: Street Vacation - Kinder Morgan Follow Up

KM does not have facilities in the referenced area.

Thanks,

Patrick Riban, PE PMP
Manager – Engineering
PPL – Pipeline Protection
Cell (304) 841-6665
Desk (713) 420-5608

From: Gull Nawaz <gnawaz@beaumontca.gov>
Sent: Friday, February 8, 2019 11:54 AM
To: PipelineInquiries <PipelineInquiries@kindermorgan.com>
Cc: Kevin Norville <KNorville@beaumontca.gov>
Subject: Street Vacation - Kinder Morgan Follow Up

[This email message was received from the Internet and came from outside of Kinder Morgan]

Hello,

The City of Beaumont is planning to vacate approximately 1,688 square feet on 5th Street and Grace Avenue fronting the Precision Stamping building in the City of Beaumont. Attached is the utility notice and the depiction of the proposed street vacation. Please confirm if Kinder Morgan's utility will or will not be affected by the proposed street vacation.

Thank You,

Gull Nawaz
Assistant Engineer
City of Beaumont
550 E. 6th Street
Beaumont, CA 92223
(951) 769-8520 ext. 358

Staff Report

TO: Mayor and City Council Members

FROM: Sean Thuilliez, Chief of Police

DATE: May 21, 2019

SUBJECT: Second Reading of Ordinance to Amend Municipal Code Chapters 5.62 and 5.70

Background and Analysis:

The City and its residents have made clear that the dispensing, cultivation, manufacture, transportation, and distribution of marijuana and marijuana products throughout the City has a significant impact on the public health, safety, and welfare, including creating increased crime, and energy consumption, nuisance activity such as loitering and criminal activity in business and residential districts, among other things. Based on the experiences of this and other cities, these negative effects on the public health, safety, and welfare are likely to occur, and continue to occur, in the City due to the establishment and operation of commercial marijuana activities.

In light of these findings, the current City code places a total ban on commercial marijuana activities, as defined, within the City, pursuant to California Business and Professions Code Section 26200, which allows local jurisdictions to regulate and/or ban marijuana businesses. However, under California Business and Professions Code Section 26090, a local jurisdiction cannot prevent delivery of marijuana or marijuana products on public roads by a California cannabis licensee acting in compliance with California state laws. Thus, to the extent the City code bans delivery entirely, the City Council is obligated to update its ordinance to reflect the State's prohibition on such ban.

Importantly, while prohibiting a local jurisdiction from prohibiting delivery on public roads, the Bureau of Cannabis Control ("Bureau") has already enacted regulations related to the delivery of marijuana throughout the State. By way of example, all delivery employees must be at least 21 years of age; delivery must be made to a physical address in California; the delivery employee may not deliver to an address located on publicly owned land or any address on land or in a building leased by a public agency; the delivery employee may not deliver to a school (grades K through 12), a day care center or youth center; etc. Relevant provisions of the Bureau regulations are attached as Attachment "B."

In light of the above, the proposed ordinance does the following, as relevant:

- 1) Reaffirms the City's position that commercial marijuana activity is prohibited to the fullest extent permitted by law;

- 2) Clarifies that delivery of marijuana in the City is only authorized to the extent permitted and required by, and in strict compliance with, State law;
- 3) Confirms that fixed storefront and non-storefront retail businesses are prohibited from operating a physical location within the City;
- 4) Provides that delivery may only be conducted upon the application, approval and issuance of a City business license; and
- 5) Provides that, in the event the State changes or enacts any law or regulations permitting a local jurisdiction to completely prohibit delivery, that such delivery shall be prohibited.

Fiscal Impact:

There are no anticipated financial impacts associated with the adoption of this ordinance amendment.

Finance Director Review: _____

Recommendation:

1. Waive the full reading and approve at its second reading, the following by title only, "An Ordinance of the City of Beaumont Amending Title 5, Chapter 5.62 of the City of Beaumont Municipal Code to Regulate the Personal, Medical, and Commercial Use of Marijuana; And Amending Title 5, Chapter 5.70, Regulating Marijuana Delivery."

City Manager Review:  _____

Attachments:

- A. Proposed ordinance
- B. Relevant provisions of the Bureau regulations

Attachment A
Proposed Ordinance

ORDINANCE NO. _____

**AN ORDINANCE OF THE CITY OF BEAUMONT
AMENDING TITLE 5, CHAPTER 5.62 OF THE CITY OF
BEAUMONT MUNICIPAL CODE TO REGULATE THE
PERSONAL, MEDICAL, AND COMMERCIAL USE OF
MARIJUANA; AND AMENDING TITLE 5, CHAPTER 5.70
REGULATING MARIJUANA DELIVERY**

WHEREAS, the City Council of the City of Beaumont has determined that it is in the best interests of the public health, safety and welfare of the City and its residents to have a strong and effective enforcement system prohibiting Commercial Marijuana Activity to the extent authorized by State law; and

WHEREAS, pursuant to California Business and Professions Code section 26200, local jurisdictions are permitted to regulate and/or ban Marijuana businesses; however, under California Business and Professions Code section 26090, a local jurisdiction cannot prevent Delivery of Marijuana or Marijuana products on public roads by a California cannabis licensee acting in compliance with California state laws; and

WHEREAS, effective January 2019, the Bureau of Cannabis Control adopted final regulations which, among other things, establish a regulatory scheme for the Delivery of Marijuana and Marijuana products throughout the State; and

WHEREAS, in light of the above, the City Council has determined that it is necessary to reaffirm its prohibition of Commercial Marijuana Activity within the City to the fullest extent permitted by law, and to clarify that Delivery of Marijuana within the City is only authorized to the extent permitted and required by, and in strict compliance with, State law.

NOW, THEREFORE, THE CITY COUNCIL OF THE CITY OF BEAUMONT DOES ORDAIN AS FOLLOWS:

SECTION 1. CEQA. The City Council finds that the actions contemplated by this Ordinance are exempt from the California Environmental Quality Act (“CEQA”) pursuant to Section 15060(c)(2) (the activity will not result in a direct or reasonably foreseeable indirect physical change in the environment) and 15060(c)(3) (the activity is not a project as defined in Section 15378) of the CEQA Guidelines, California Code of Regulations, Title 14, Chapter 3, because it has no potential for resulting in physical change to the environment, directly or indirectly.

SECTION 2. Severability. The City Council hereby declares that if any provision, section, paragraph, sentence, or word of this Ordinance is rendered or declared to be invalid or unconstitutional by any final court action in a court of competent jurisdiction, or by reason of any preemptive legislation, such invalidity shall not affect the other provisions, sections, paragraphs, sentences, or words of this Ordinance, and to this end the provisions of this Ordinance are severable. The City Council declares that it would have adopted this Ordinance irrespective of the

invalidity of any particular portion thereof and intends that the invalid portions should be severed and the balance of the Ordinance enforced.

SECTION 3. Violation of Prior Ordinances. Neither the adoption of this Ordinance nor the repeal of any other ordinance of this City shall in any manner affect the prosecution of any violation of any City ordinance or provision of the City of Beaumont Municipal Code, committed prior to the effective date hereof, nor be construed as a waiver of any penalty or the penal provisions applicable to any violation thereof.

SECTION 4. The City Council hereby amends Title 5 (Business Taxes, Licenses, and Regulations), Division II, Chapter 5.62 to read in its entirety as follows:

Chapter 5.62

PROHIBITION OF COMMERCIAL MARIJUANA ACTIVITY AND REGULATION OF PERSONAL MARIJUANA USE AND CULTIVATION

5.62.010 - Purpose.

It is the purpose and intent of this Chapter to: (1) regulate indoor personal Cultivation of Marijuana to the fullest extent permitted by State law; (2) completely prohibit outdoor Cultivation of Marijuana; and (3) completely prohibit Commercial Marijuana Activity—whether medical or recreational within the City of Beaumont, to the fullest extent permitted by law.

5.62.020 - Definitions.

- A. "*Marijuana*" shall mean all parts of the plant *Cannabis sativa* Linnaeus, *Cannabis indica*, or *Cannabis ruderalis*, whether growing or not; the seeds thereof; the resin, whether crude or purified, extracted from any part of the plant; and every compound, manufacture, salt, derivative, mixture, or preparation of the plant, its seeds, or resin. "*Marijuana*" also means the separated resin, whether crude or purified, obtained from Marijuana. "*Marijuana*" also means Marijuana as defined by Section 11018 of the Health and Safety Code.

For the purposes of this Chapter, "*Marijuana*" does not mean "*industrial hemp*" as defined by Section 81000 of the Food and Agriculture Code or Section 11018.5 of the Health and Safety Code. "*Marijuana*" does not include the mature stalks of the plant, fiber produced from the stalks, oil or cake made from the seeds of the plant, any other compound, manufacture, salt, derivative, mixture, or preparation of the mature stalks (except the resin extracted therefrom), fiber, oil, or cake, or the sterilized seed of the plant which is incapable of germination.

- B. "*Commercial Marijuana Activity*" includes the Cultivation, possession, manufacture, distribution, processing, storing, laboratory testing, packaging, labeling, transportation, and/or sale of Marijuana and/or Marijuana products. Commercial Marijuana Activity does not include:

- (1) The activity of a qualified patient or primary caregiver as provided in Business and Professions Code Section 26033; or

- (2) A person 21 years of age or older who, in strict accordance with State law and/or regulations, as may be amended from time to time:
 - (i) possesses, processes, transports, purchases, obtains, or gives away to persons 21 years of age or older without any compensation whatsoever, no more than 28.5 grams of Marijuana not in the form of concentrated cannabis; or
 - (ii) possesses, processes, transports, purchases, obtains, or gives away to persons 21 years of age or older without any compensation whatsoever, not more than eight grams of Marijuana in the form of concentrated cannabis, including as contained in Marijuana products; or
 - (iii) possesses, plants, cultivates, harvests, dries, or processes not more than six living Marijuana plants and possess the Marijuana produced by those plants; or
 - (iv) smokes or ingests Marijuana or Marijuana products; or
 - (v) possesses, transports, purchases, obtains, uses, manufactures, or gives away Marijuana accessories to persons 21 years of age or older without any compensation whatsoever.
- C. "*Cultivation*" means any activity involving the planting, growing, harvesting, drying, curing, grading, or trimming of Marijuana, whether within a structure completely or partially enclosed, or outdoors.
- D. "*Person*" means any individual, firm, partnership, joint venture, corporation, association, limited liability company, estate, trust, business trust, receiver, syndicate, collective, cooperative, dispensary, club, society, or other organization or group acting as a unit, and the plural as well as the singular. The term individual shall include any owner, manager, proprietor, employee, volunteer, salesperson, primary caregiver or qualified patient.
- E. "*Private residence*" means a house, an apartment unit, a mobile home, or any other similar residential dwelling serving as an individual's primary residence.

5.62.030 - Personal use and Cultivation.

- A. For purposes of this subsection, personal use, possession, process, purchase, transport, and/or dissemination of Marijuana shall be considered prohibited and unlawful in all areas of the City to the fullest extent such prohibition is permissible under State law.

- B. Outdoor Cultivation. No person may plant, cultivate, harvest, dry, or process Marijuana plants outdoors in any zoning district of the City. No permit or any other license or entitlement for use, nor any business license, shall be approved or issued for the opening, establishment, maintenance or operation of any such use or activity. In the event of a determination by the California Attorney General that nonmedical use of Marijuana is lawful in the State of California under federal law, outdoor Cultivation of Marijuana shall be prohibited and/or regulated to the fullest extent permitted by State law.
- C. Indoor Cultivation. No person, including a qualified patient or primary caregiver, may plant, cultivate, harvest, dry, or process Marijuana plants except for personal use inside a Private Residence or accessory structure to a Private Residence located upon the grounds of a Private Residence, and only in strict accordance with State law and/or regulations, and the City Code, as may be amended from time to time. This provision shall not be construed to authorize, regulate, permit, license, or otherwise allow indoor Cultivation for commercial use or purposes; such activity is expressly prohibited in all zones throughout the City.

5.62.040 - Commercial Marijuana Activity.

The opening, establishment, maintenance or operation of any business for the purpose of conducting Commercial Marijuana Activity, whether for medical or recreational use, is prohibited in all zones throughout the City. No permit or any other license or entitlement for use, nor any business license, shall be approved or issued for the establishment, maintenance, or operation of any business engaged in Commercial Marijuana Activity.

5.62.050 - Violation and enforcement.

1. Any condition caused or permitted to exist in violation of any provisions of this Chapter, the City Code, or State or City law is declared a public nuisance and may be abated by the City either pursuant to Chapter 8.32 of the Beaumont Municipal Code or any other available civil and/or criminal remedy, including but not limited to a restraining order, temporary and permanent injunctive relief, and other relief set forth in this Chapter, City Code and/or State Law.
2. Any Person found to be in violation of or in non-compliance with any of the requirements of this Chapter or applicable provisions of the Beaumont Municipal Code shall be subject to any enforcement remedies available under the law and/or the Beaumont Municipal Code including, but not limited to, Chapter 1.17 and Chapter 8.32.
3. Any Person violating any of the provisions of this Chapter or any provisions or part hereof, shall be guilty of a misdemeanor, and upon conviction thereof shall be punishable by a fine of up to \$1,000.00 per day per violation or by imprisonment for a period of not more than six months, or by both such fine and imprisonment.

No civil action shall prevent criminal prosecution for any violation of the provisions of this Chapter, City Code and/or State law.

4. In lieu of issuing a misdemeanor citation, the City may reduce the penalty to an infraction or issue an administrative citation, and/or assess an administrative fine up to the maximum amount(s) permitted by law and the Code.
5. Each violation of this Chapter shall constitute a separate violation and each violation may be charged as a separate count in the event of administrative or criminal enforcement action.

SECTION 5. The City Council hereby amends Title 5 (Business Taxes, Licenses, and Regulations), Division II, Chapter 5.70 “Mobile Marijuana Dispensaries” to read in its entirety as follows:

CHAPTER 5.70
DELIVERY OF MARIJUANA

5.70.010 - Definitions.

The following words and phrases shall, for the purposes of this Chapter, have the meanings respectively ascribed to them by this section, as follows:

"Delivery" means the commercial transfer of Marijuana or Marijuana products to a customer of a business engaged in Commercial Marijuana Activity (as defined in City Code Section 5.62.020). "Delivery" also includes the use by a retailer of any technology platform owned and controlled by a retailer, or independently licensed under State law, that enables customers to arrange for or facilitate the commercial transfer by a licensed retailer of Marijuana or Marijuana product.

"Delivery employee" means an individual employed by a licensed retailer or licensed microbusiness authorized to engage in retail sales who delivers Marijuana goods from the licensed retailer or licensed microbusiness premises to a customer at a physical address.

"Person" means any individual, firm, partnership, joint venture, corporation, association, limited liability company, estate, trust, business trust, receiver, syndicate, collective, cooperative, dispensary, club, society, or other organization or group acting as a unit, and the plural as well as the singular. The term individual shall include any owner, manager, proprietor, employee, volunteer, salesperson, primary caregiver or qualified patient.**5.70.020 – Delivery of Marijuana.**

Delivery of Marijuana within the City shall be allowed only to the extent permissible under State law, and in strict compliance therewith, including maintaining, prior to operation, an applicable State license/permit therefore. Any Delivery conducted not in strict compliance with State law and/or regulations and any applicable City or local law is prohibited. This provision does not permit any fixed storefront or non-storefront retail business to operate within and maintain a physical location within the City; such retail Commercial Marijuana Activity is expressly prohibited.

5.70.030 – Business License Required.

Notwithstanding Municipal Code Section 5.62.040, Marijuana Delivery shall only be permitted within the City upon the application, approval and issuance of a City business license as provided in Chapter 5.04, *et seq.* of the Beaumont Municipal Code. A City business license is a revocable privilege, which shall be subject to revocation/suspension upon a violation of any provision of this Chapter and/or State law/regulations.

5.70.040 - Violations.

1. Any condition caused or permitted to exist in violation of any provisions of this Chapter, the City Code, or State or City law is declared a public nuisance and may be abated by the City either pursuant to Chapter 8.32 of the Beaumont Municipal Code or any other available civil and/or criminal remedy, including but not limited to a restraining order, temporary and permanent injunctive relief, and other relief set forth in this Chapter, City Code and/or State Law.
2. Any Person found to be in violation of or in non-compliance with any of the requirements of this Chapter or applicable provisions of the Beaumont Municipal Code shall be subject to any enforcement remedies available under the law and/or the Beaumont Municipal Code including, but not limited to, Chapter 1.17 and Chapter 8.32.
3. Any Person violating any of the provisions of this Chapter or any provisions or part hereof, shall be guilty of a misdemeanor, and upon conviction thereof shall be punishable by a fine of up to \$1,000.00 per day per violation or by imprisonment for a period of not more than six months, or by both such fine and imprisonment. No civil action shall prevent criminal prosecution for any violation of the provisions of this Chapter, City Code and/or State law.
4. In lieu of issuing a misdemeanor citation, the City may reduce the penalty to an infraction or issue an administrative citation, and/or assess an administrative fine up to the maximum amount(s) permitted by law and the Code.
5. Each violation of this Chapter shall constitute a separate violation and each violation may be charged as a separate count in the event of administrative or criminal enforcement action.

5.70.050 – Prohibition of Delivery

It is the intent of the City Council to prohibit all Commercial Marijuana Activity within the City. In the event the State enacts any law or regulation permitting a local jurisdiction to completely prohibit the Delivery of Marijuana, Sections 5.70.020 and 5.70.030 shall be null and void, and all Commercial Marijuana Activity, including Delivery, shall be prohibited.

SECTION 6. Effective Date and Publication. The Mayor shall sign and the City Clerk shall certify to the passage of this Ordinance and cause the same or a summary thereof to be published within 15 days after adoption in accordance with Government Code Section 36933. This Ordinance shall take effect 30 days after adoption in accordance with Government Code Section 36937.

NOW, THEREFORE, BE IT ORDAINED that the City Council of the City of Beaumont, California, approves an amendment to the City Code.

INTRODUCED AND READ for the first time and ordered posted at a regular meeting of the City Council of the City of Beaumont, California, held on the ____ day of _____, 2019, by the following roll call vote:

- AYES:
- NOES:
- ABSENT:
- ABSTAIN:

PASSED, APPROVED AND ADOPTED at a regular meeting of the City Council of the City of Beaumont, California, held on the ____ day of _____, 2019.

- AYES:
- NOES:
- ABSENT:
- ABSTAIN:

Julio Martinez, Mayor

Attest: _____
Steven Mehlman, City Clerk

Approved as to form:

John O. Pinkney, City Attorney

Attachment B

Relevant Provisions of Bureau Regulations

packaging.

Authority: Section 26013, Business and Professions Code. Reference: Sections 26070.1 and 26120, Business and Professions Code.

§ 5414. Non-Storefront Retailer.

- (a) A non-storefront retailer licensee shall be authorized to conduct retail sales exclusively by delivery as defined in Business and Professions Code section 26001(p).
- (b) A complete application for a non-storefront retailer license shall include all the information required in an application for a retailer license.
- (c) A non-storefront retailer licensee shall comply with all the requirements applicable to retailer licensees, except for those provisions related to public access to the licensed premises and the retail area.
- (d) The licensed premises of a non-storefront retailer licensee shall be closed to the public.

Authority: Section 26013, Business and Professions Code. Reference: Sections 26012 and 26070, Business and Professions Code.

§ 5415. Delivery Employees.

- (a) All deliveries of cannabis goods shall be performed by a delivery employee who is directly employed by a licensed retailer.
- (b) Each delivery employee of a licensed retailer shall be at least 21 years of age.
- (c) All deliveries of cannabis goods shall be made in person. A delivery of cannabis goods shall not be made through the use of an unmanned vehicle.
- (d) The process of delivery begins when the delivery employee leaves the retailer's licensed premises with the cannabis goods for delivery. The process of delivering ends when the delivery employee returns to the retailer's licensed premises after delivering the cannabis goods, or attempting to deliver cannabis goods, to the customer(s). During the process of delivery, the licensed retailer's delivery employee may not engage in any activities except for cannabis goods delivery and necessary rest, fuel, or vehicle repair stops.
- (e) A delivery employee of a licensed retailer shall, during deliveries, carry a copy of the retailer's current license, the employee's government-issued identification, and an identification badge provided by the employer pursuant to section 5043 of this division.
- (f) Prior to providing cannabis goods to a delivery customer, a delivery employee shall confirm the identity and age of the delivery customer as required by section 5404 of this division and ensure that all cannabis goods sold comply with requirements of section 5413 of this division.
- (g) A licensed retailer shall maintain an accurate list of the retailer's delivery employees and shall provide the list to the Bureau upon request.

Authority: Section 26013, Business and Professions Code. Reference: Sections 26070 and 26090, Business and Professions Code.

§ 5415.1. Deliveries Facilitated by Technology Platforms.

(a) A licensed retailer or licensed microbusiness shall not sell or otherwise transfer any cannabis goods to a customer through the use of an unlicensed third party, intermediary business, broker, or any other business or entity.

(b) Notwithstanding subsection (a) of this section, a licensed retailer or licensed microbusiness may contract with a service that provides a technology platform to facilitate the sale and delivery of cannabis goods, in accordance with all of the following:

(1) The licensed retailer or licensed microbusiness does not allow for delivery of cannabis goods by the technology platform service provider.

(2) The licensed retailer or licensed microbusiness does not share in the profits of the sale of cannabis goods with the technology platform service provider, or otherwise provide for a percentage or portion of the cannabis goods sales to the technology platform service provider.

(3) The licensed retailer or licensed microbusiness shall not advertise or market cannabis goods in conjunction with the technology platform service provider, outside of the technology platform, and shall ensure that the technology platform service provider does not use the licensed retailer's or licensed microbusiness's license number or legal business name on any advertisement or marketing that primarily promotes the services of the technology platform.

(4) The licensed retailer or licensed microbusiness shall ensure the following information is provided to customers:

(A) Any cannabis goods advertised or offered for sale on or through the technology platform shall disclose, at a minimum, the licensed retailer's or licensed microbusiness's legal business name and license number.

(B) Customers placing an order for cannabis goods through the technology platform shall be able to easily identify the licensed retailer or licensed microbusiness that each cannabis good is being ordered or purchased from. This information shall be available to the customer prior to the customer placing an order or purchasing the cannabis goods.

(5) All required sales invoices and receipts, including any receipts provided to the customer, shall disclose, at a minimum, the licensed retailer's or licensed microbusiness's legal business name and license number.

(6) All other delivery, marketing, and advertising requirements under this division are complied with.

Authority: Section 26013, Business and Professions Code. Reference: Sections 26001, 26070, 26090, 26151 and 26152, Business and Professions Code.

§ 5416. Delivery to a Physical Address.

(a) A delivery employee may only deliver cannabis goods to a physical address in California.

(b) A delivery employee shall not leave the State of California while possessing cannabis goods.

(c) A delivery employee shall not deliver cannabis goods to an address located on publicly owned land or any address on land or in a building leased by a public agency. This prohibition applies to land held in trust by the United States for a tribe or an individual tribal member unless the delivery is authorized by and consistent with applicable tribal law.

(d) A delivery employee may deliver to any jurisdiction within the State of California provided that such delivery is conducted in compliance with all delivery provisions of this division.

(e) A delivery employee shall not deliver cannabis goods to a school providing instruction in kindergarten or any grades 1 through 12, day care center, or youth center.

Authority: Section 26013, Business and Professions Code. Reference: Sections 26070 and 26090, Business and Professions Code.

§ 5417. Delivery Vehicle Requirements.

(a) A licensed retailer's delivery employee, carrying cannabis goods for delivery, shall only travel in an enclosed motor vehicle. Any vehicle used in the delivery of cannabis goods shall be operated by a delivery employee of the licensee. A vehicle used in the delivery of cannabis goods shall not have any marking or other indications on the exterior of the vehicle that may indicate that the delivery employee is carrying cannabis goods for delivery. Only the licensee or an employee of the retailer licensee for whom delivery is being performed shall be in the delivery vehicle.

(b) While carrying cannabis goods for delivery, a licensed retailer's delivery employee shall ensure the cannabis goods are not visible to the public. Cannabis goods shall be locked in a fully enclosed box, container, or cage that is secured on the inside of the vehicle. No portion of the enclosed box, container, or cage shall be comprised of any part of the body of the vehicle or trailer. For purposes of this section, the inside of the vehicle includes the trunk.

(c) A licensed retailer's delivery employee shall not leave cannabis goods in an unattended motor vehicle unless the motor vehicle is locked and equipped with an active vehicle alarm system. Any cannabis goods left in an unattended vehicle must be stored in a container as required in subsection (b) of this section.

(d) A vehicle used for the delivery of cannabis goods shall be outfitted with a dedicated Global Positioning System (GPS) device for identifying the geographic location of the delivery vehicle and recording a history of all locations traveled to by the delivery employee while engaged in delivery. A dedicated GPS device must be owned by the licensee and used for delivery only. The device shall be either permanently or temporarily affixed to the delivery vehicle and shall remain active and inside of the delivery vehicle at all times during delivery. At all times, the licensed retailer shall be able to identify the geographic location of all delivery vehicles that are making deliveries for the licensed retailer and document the history of all locations traveled to by a delivery employee while engaged in delivery. A licensed retailer shall provide this information to the Bureau upon request. The history of all locations traveled to by a delivery employee while engaging in delivery shall be maintained by the licensee for a minimum of 90 days.

(e) Upon request, a licensed retailer shall provide the Bureau with information regarding any motor vehicle used for the delivery of cannabis goods, including the vehicle's make, model, color, Vehicle Identification Number, license plate number and Department of Motor Vehicles registration information.

(f) Any motor vehicle used by a licensed retailer to deliver cannabis goods is subject to inspection by the Bureau. Vehicles used to deliver cannabis goods may be stopped and inspected by the Bureau at any licensed premises or during delivery.

Authority: Section 26013, Business and Professions Code. Reference: Sections 26070 and 26090, Business and Professions Code.

§ 5418. Cannabis Goods Carried During Delivery.

(a) A licensed retailer's delivery employee shall not carry cannabis goods in the delivery vehicle with a value in excess of \$5,000 at any time. The value of cannabis goods carried in the delivery vehicle for which a delivery order was not received and processed by the licensed retailer prior to the delivery employee departing from the licensed premises may not exceed \$3,000.

(b) For the purposes of this section, the value of cannabis goods shall be determined using the current retail price of all cannabis goods carried by, or within the delivery vehicle of, the licensed retailer's delivery employee.

(c) A delivery employee may only carry cannabis goods in the delivery vehicle and may only perform deliveries for one licensed retailer at a time. A delivery employee must depart and return to the same licensed premises before taking possession of any cannabis goods from another licensee to perform deliveries.

(d) A licensed retailer's delivery employee shall not leave the licensed premises with cannabis goods without at least one delivery order that has already been received and processed by the licensed retailer.

(e) Before leaving the licensed premises, the licensed retailer's delivery driver must have a delivery inventory ledger of all cannabis goods provided to the licensed retailer's delivery driver. For each cannabis good, the delivery inventory ledger shall include the type of good, the brand, the retail value, the track and trace identifier, and the weight, volume or other accurate measure of the cannabis good. All cannabis goods prepared for an order that was received and processed by the licensed retailer prior to the delivery driver's departure from the licensed premises must be clearly identified on the inventory ledger. After each customer delivery, the delivery inventory ledger must be updated to reflect the current inventory in possession of the licensed retailer's delivery driver. Delivery inventory ledgers may be maintained electronically.

(f) The licensed retailer's delivery driver shall maintain a log that includes all stops from the time the licensed retailer's delivery driver leaves the licensed premises to the time that the licensed retailer's delivery driver returns to the licensed premises, and the reason for each stop. The log shall be turned in to the licensed retailer when the licensed retailer's delivery driver returns to the licensed premises. The licensed retailer must maintain the log as a commercial cannabis activity record as required by this division. The log may be maintained electronically.

(g) Prior to arrival at any delivery location, the licensed retailer must have received a delivery request from the customer and provided the delivery request receipt to the licensed retailer's delivery driver electronically or in hard copy. The delivery request receipt provided to the licensed retailer's delivery driver shall contain all of the information required in section 5420 of this division, except for the date and time the delivery was made, and the signature of the customer.

(h) Immediately upon request by the Bureau or any law enforcement officer, the licensed

retailer's delivery driver shall provide:

- (1) All delivery inventory ledgers from the time the licensed retailer's delivery driver left the licensed premises up to the time of the request;
 - (2) All delivery request receipts for cannabis goods carried by the driver, in the delivery vehicle, or any deliveries that have already been made to customers; and
 - (3) The log of all stops from the time the licensed retailer's delivery driver left the licensed premises up to the time of the request.
- (i) If a licensed retailer's delivery driver does not have any delivery requests to be performed for a 30-minute period, the licensed retailer's delivery driver shall not make any additional deliveries and shall return to the licensed premises. Required meal breaks shall not count toward the 30-minute period.
 - (j) Upon returning to the licensed premises, all undelivered cannabis goods shall be returned to inventory and all necessary inventory and track-and-trace records shall be updated as appropriate that same day.

Authority: Section 26013, Business and Professions Code. Reference: Sections 26070, 26090 and 26160, Business and Professions Code.

§ 5419. Cannabis Consumption During Delivery.

A licensed retailer's delivery employees shall not consume cannabis goods while delivering cannabis goods to customers.

Authority: Section 26013, Business and Professions Code. Reference: Sections 26070 and 26090, Business and Professions Code.

§ 5420. Delivery Request Receipt.

A licensed retailer shall prepare a hard copy or electronic delivery request receipt for each delivery of cannabis goods.

- (a) The delivery request receipt shall contain the following:
- (1) The name and address of the licensed retailer;
 - (2) The first name and employee number of the licensed retailer's delivery employee who delivered the order;
 - (3) The first name and employee number of the licensed retailer's employee who prepared the order for delivery;
 - (4) The first name of the customer and a licensed retailer-assigned customer number for the person who requested the delivery;
 - (5) The date and time the delivery request was made;
 - (6) The delivery address;
 - (7) A detailed description of all cannabis goods requested for delivery. The description shall

include the weight, volume, or any other accurate measure of the amount of all cannabis goods requested;

(8) The total amount paid for the delivery, including any taxes or fees, the cost of the cannabis goods, and any other charges related to the delivery; and

(9) Upon delivery, the date and time the delivery was made, and the handwritten or electronic signature of the customer who received the delivery.

(b) At the time of the delivery, the delivery employee of the retailer shall provide the customer who placed the order with a hard or electronic copy of the delivery request receipt. The delivery employee shall retain a hard or electronic copy of the signed delivery request receipt for the licensed retailer's records.

(c) For the purposes of this section, an employee number is a distinct number assigned by a licensed retailer to an employee that would allow the licensed retailer to identify the employee in documents or records using the employee number rather than the employee's full name. A licensed retailer shall be able to identify the employee associated with each employee number upon request from the Bureau.

(d) For the purposes of this section, a customer number is a distinct number assigned by a licensed retailer to a customer that would allow the licensed retailer to identify the customer in documents or records using the customer number rather than the customer's full name. A licensed retailer shall be able to identify the customer associated with each customer number upon request from the Bureau.

Authority: Section 26013, Business and Professions Code. Reference: Sections 26070, 26090 and 26160, Business and Professions Code.

§ 5421. Delivery Route.

While making deliveries of cannabis goods, a licensed retailer's delivery employee shall only travel from the retailer's licensed premises to the delivery address; from one delivery address to another delivery address; or from a delivery address back to the retailer's licensed premises. A delivery employee of a licensed retailer shall not deviate from the delivery path described in this section, except for necessary rest, fuel, or vehicle repair stops, or because road conditions make continued use of the route unsafe, impossible, or impracticable.

Authority: Section 26013, Business and Professions Code. Reference: Sections 26070 and 26090, Business and Professions Code.

§ 5422. Receiving Shipments of Inventory.

(a) A licensed retailer shall receive a shipment of cannabis goods only from a licensed distributor or licensed microbusiness authorized to engage in distribution.

(b) A licensed retailer shall accept shipments of cannabis goods only between the hours of 6:00 a.m. Pacific Time and 10:00 p.m. Pacific Time.

(c) During business hours, shipments of cannabis goods shall not enter the licensed premises through an entrance or exit that is available for use by the public.

(d) A licensed retailer whose licensed premises only has one entryway may be exempt from the

FOURTH AMENDED TOLLING AGREEMENT

This Agreement (the "Agreement") is made effective June 10, 2016 (the "Effective Date"), by and among the City of Beaumont, and its related entities, including but not limited to, the Beaumont Utility Authority, Beaumont Finance/Financing Authority, the Beaumont Redevelopment Agency and its Successor Agency, and the Beaumont Conservation Authority (the City and its entities are collectively referred to herein as "City"), on the one hand, and Norton Rose Fulbright US LLP, formerly named Fulbright & Jaworksi LLP ("NRF-US"), on the other. The City and NRF-US shall sometimes herein be referred to individually as "Party" and/or collectively as the "Parties".

WHEREAS, the City contends that NRF-US provided legal services to the City in connection with the issuance of bonds/securities; and

WHEREAS, the City may have certain claims against NRF-US arising out of services provided by NRF-US; and

WHEREAS, NRF-US denies that the City has any claims, and may have affirmative defenses in response to any City claims, arising out of services NRF-US provided to City; and

WHEREAS, the City desires to preserve any and all claims that may exist as of the effective date relating to NRF-US providing services in connection with the issuance of bonds/securities; and

WHEREAS, no Party to this Agreement admits any wrongful acts or omissions and all Parties deny any liability to the other Parties; and

WHEREAS, the Parties previously entered into a Tolling Agreement that was set to expire on June 10, 2017, a First Amended Tolling Agreement that was set to expire on June 10, 2018, a Second Amended Tolling Agreement that was set to expire on December 10, 2018, and a Third Amended Tolling Agreement that is set to expire June 10, 2019. The Parties desire

to enter into a Fourth Amended Tolling Agreement to further toll the Statutes of Limitations (as hereinafter defined) to permit further investigation of the factual and legal issues involved, and to allow for further discussions and possible negotiations without causing any prejudice or loss of rights to any party;

NOW THEREFORE, in consideration of the foregoing, and other valuable consideration the adequacy of which is admitted by the Parties, the Parties agree as follows:

1. Tolling of Statutes of Limitations. The Parties hereto hereby agree that the statute of limitations for any claims of any Party arising out of or relating to the above-described services and all other applicable Statutes of Repose and/or other doctrines of claim preclusion based upon the passage of time (herein collectively called the "Statutes of Limitations") are hereby tolled for the period commencing on the Effective Date through and including September 10, 2019. This tolling accrues for the benefit of each of the Parties hereto, and includes but is not limited to any claims related to fees and costs.

2. No Admission. The execution of this Agreement shall not constitute an admission by any Party of the matters addressed in the recitals herein. The execution of this Agreement shall not prohibit any Party from asserting any defense based upon any claim that an applicable Statutes of Limitations may have expired prior to the effective date of this Agreement. This Agreement is not, and shall not be construed to be (i) an admission or indication that either Party bears or does not bear any actual or potential liability to any other person (whether or not a Party to this Agreement) on any claim, action or complaint whatsoever, or (ii) an acknowledgment by any Party that any claim has or has not already been barred, or is or is not about to be barred, by the Statutes of Limitations. This Agreement may not be used or be admissible in evidence for any purpose other than to establish the tolling of the Statutes of Limitations as set out above.

3. Effect of Tolling. This Agreement shall suspend the running of any and all applicable Statutes of Limitations for the period commencing on the Effective through and including September 10, 2019 (the "Tolling Period"). If no legal action has been filed as of September 10, 2019, any and all applicable Statutes of Limitations shall again begin to run at that time. The Tolling Period provided for in this Agreement shall be excluded from any calculation of any Statutes of Limitations for purposes of determining whether or not any Statutes of Limitations has expired taking into account all periods prior to the Effective Date and, if applicable, after termination of the Tolling Period.

4. Right to Pursue Claims/Termination. Any Party to this Agreement may terminate the Tolling Period under this Agreement by delivering notice in writing declaring such termination, in which event the Tolling Period under this Agreement shall terminate thirty (30) days from the date of actual receipt of such notice, instead of the termination date specified. Any notices required or permitted under this Agreement shall be delivered to the following persons on behalf of the Parties. Delivery shall be effective upon confirmation of receipt of an emailed or mailed notice.

To City:

City of Beaumont
Attention: City Manager & City Attorney
550 East Sixth Street
Beaumont, CA 92223

To NRF-US:

Attn: David S. Eisen
555 South Flower Street
Forty-First Floor
Los Angeles, CA 90071
Attention: Donald Hunt

5. Integration. This Agreement represents the full and complete Agreement by and between the Parties regarding the subject matter of this Agreement, being the tolling of all

applicable Statutes of Limitations. This Agreement is, and is intended by the Parties to be, an integration of any and all prior Agreements or understandings, oral or written, with respect to the subject matter hereof. This Agreement shall not be modified or amended except by a writing signed by all Parties.

6. Counterparts. This Agreement may be executed in duplicate counterparts, and faxed signatures shall be deemed sufficient as originals.

7. Binding Effect. Upon execution of this Agreement by all Parties, this Agreement shall extend to and be binding upon and inure to the benefit of the Parties hereto, the persons named herein, their agents, partners, shareholders, guarantors, heirs, successors and assigns.

8. Advice of Counsel. Each Party acknowledges that the Party has given mature and careful thought to this Tolling Agreement, has had the opportunity to review this Tolling Agreement independently with legal counsel of the Party's independent choice, and/or has the requisite experience and sophistication to agree to, interpret, and understand the particular language of this Tolling Agreement. If any Person claims any ambiguity exists in, or disputes the interpretation of, this Tolling Agreement, no one will resolve any ambiguity in, or dispute regarding the interpretation of, this Tolling Agreement by any rule providing for interpretation against the Person who causes the uncertainty to exist or against the Person who is responsible for drafting this Tolling Agreement.

9. Choice of Law. This Agreement is entered into and to be performed in Riverside County, California. The laws of the State of California will govern the application, enforcement, and interpretation of this Tolling Agreement except to the extent that the laws of the United States of America pre-empt the laws of the State of California. Nothing in this

///

Tolling Agreement constitutes a choice of law as to the claims themselves, but only as to the application, enforcement, and interpretation of this Tolling Agreement.

CITY OF BEAUMONT and Related Entities

Dated: _____ 2019

By: _____
Its:

Dated: 3/13/ 2019

NORTON ROSE FULBRIGHT US LLP

By: 
Its:

THIRD AMENDED TOLLING AGREEMENT

This Agreement (the "Agreement") is made effective June 10, 2016 (the "*Effective Date*"), by and among the City of Beaumont, and its related entities, including but not limited to, the Beaumont Utility Authority, Beaumont Finance/Financing Authority, the Beaumont Redevelopment Agency and its Successor Agency, and the Beaumont Conservation Authority (the City and its entities are collectively referred to herein as "*City*"), on the one hand, and Rod Gunn individually and Rod Gunn Associates, Inc. (collectively "RGA"), on the other. The City and RGA shall sometimes herein be referred to individually as "Party" and/or collectively as the "Parties".

WHEREAS, the City contends that RGA provided finance, bond and related services to City; and

WHEREAS, the City may have certain claims against RGA arising out of or related to the services RGA provided to City; and

WHEREAS, RGA may have certain affirmative defenses against the City arising out of or related to the services RGA provided to City; and

WHEREAS, the City wishes to preserve any and all claims that may exist as of the effective date relating to services provided by RGA; and

WHEREAS, no Party to this Agreement admits any wrongful acts or omissions and all Parties deny any liability to the other Parties; and

WHEREAS, the Parties previously entered into a Tolling Agreement that was set to expire on June 23, 2017, a First Amended Tolling Agreement that was set to expire on June 23, 2018 and a Second Amended Tolling Agreement that was set to expire on June 23, 2019. The Parties desire to enter into a Third Amended Tolling Agreement to further toll the running

of any applicable statutes of limitation or any other limitations on the period by which claims may be brought related to RGA's representation of the City and/or its agreement to provide finance, bond and/or related services, and all now and later discovered claims related thereto.

NOW THEREFORE, in consideration of the foregoing and other valuable consideration the adequacy of which is admitted by the Parties, the Parties agree as follows:

1. Tolling of Statute of Limitations. The Parties hereto hereby agree that the Statute of Limitations, for any claims of any Party arising out of or relating to the above-described services and all other applicable Statutes of Limitation, Statute of Repose and/or other doctrines of claim preclusion based upon the passage of time are hereby tolled effective from June 23, 2016 through and including June 23, 2020. This tolling accrues for the benefit of each of the Parties hereto, and includes but is not limited to any claims related to fees and costs.

2. No Admission. The execution of this Agreement shall not constitute an admission by any Party of the matters addressed in the recitals herein. The execution of this Agreement shall not prohibit any Party from asserting any defense based upon any claim that an applicable Statute of Limitations may have expired prior to the effective date of this Agreement.

3. Effect of Tolling. This Agreement shall suspend the running of any and all applicable Statutes of Limitation (or other defense based upon the passage of time) and statute of repose through and including June 23, 2020 (the "Tolling Period"). If no legal action has been filed as of June 23, 2020, any and all applicable Statutes of Limitation shall again begin to run at that time. The Tolling Period provided for in this Agreement shall be excluded from any calculation of any Statute of Limitations (or other defense based upon the passage of time) for purposes of determining whether or not any Statute of Limitations has expired.

4. Right to Pursue Claims/Termination. Any Party to this Agreement may terminate the Tolling Period under this Agreement by delivering notice in writing declaring such termination, in which event the Tolling Period under this Agreement shall terminate thirty (30) days from the date of actual receipt of such notice. Any notices required or permitted under this Agreement shall be delivered to the following persons on behalf of the Parties. Delivery shall be effective upon confirmation of personal delivery or receipt of an emailed or mailed notice.

To City:

City of Beaumont
Attention: City Manager & City Attorney
550 East Sixth Street
Beaumont, CA 92223

To RGA:

Rod Gunn Associates, Inc. / Rod Gunn
rodgunn@live.com
Attn: Rodney Larry Gunn
7900 Mossy Pond
Olalla, WA 98359

5. Integration. This Agreement represents the full and complete Agreement by and between the Parties regarding the subject matter of this Agreement, being the tolling of all applicable statutes of limitations and statutes of repose. This Agreement is, and is intended by the Parties to be, an integration of any and all prior Agreements or understandings, oral or written, with respect to the subject matter hereof. This Agreement shall not be modified or amended except by a writing signed by all Parties.

6. Counterparts. This Agreement may be executed in duplicate counterparts, and faxed signatures shall be deemed sufficient as originals.

7. Binding Effect. Upon execution of this Agreement by all Parties, this Agreement shall extend to and be binding upon and inure to the benefit of the Parties hereto, the persons named herein, their agents, partners, shareholders, guarantors, heirs, successors and assigns.

8. Advice of Counsel. Each Party acknowledges that the Party has given mature and careful thought to this Tolling Agreement, has had the opportunity to review this Tolling Agreement independently with legal counsel of the Party's independent choice, and/or has the requisite experience and sophistication to agree to, interpret, and understand the particular language of this Tolling Agreement. If any Person claims any ambiguity exists in, or disputes the interpretation of, this Tolling Agreement, no one will resolve any ambiguity in, or dispute regarding the interpretation of, this Tolling Agreement by any rule providing for interpretation against the Person who causes the uncertainty to exist or against the Person who is responsible for drafting this Tolling Agreement.

9. Choice of Law. This Agreement is entered into and to be performed in Riverside County, California. The laws of the State of California will govern the application, enforcement, and interpretation of this Tolling Agreement except to the extent that the laws of the United States of America pre-empt the laws of the State of California. Nothing in this

///

///

///

Tolling Agreement constitutes a choice of law as to the claims themselves, but only as to the application, enforcement, and interpretation of this Tolling Agreement.

CITY OF BEAUMONT and Related Entities

Dated: _____ 2019

By:
Its:

ROD GUNN ASSOCIATES, INC.

Dated: May 7 2019

RG
By:
~~Its~~

Dated: May 7 2019

RG
By: **ROD GUNN, an individual**

Staff Report

TO: Mayor and City Council Members
 FROM: Melana Taylor, Director of Finance
 DATE: May 21, 2019
 SUBJECT: March 2019 Financial Reports

Background and Analysis:

The March 2019 Monthly Financial Reports are attached for review, as follows:

1. General Fund (summary level) – Actual versus Budget, current month and year to date.
2. General Fund (summary level) – current versus Prior Year, current month and year to date.
3. Waste Water Fund (summary level) – Actual versus Budget, current month and year to date.
4. Waste Water Fund (summary level) – Current versus Prior Year, current month and year to date.
5. Treasurer’s Report – Cash Account Reconciled Balance allocations by Fund.

These financial reports were provided to the Finance and Audit Committee at their meeting on May 6, 2019.

The March financials should result in 25.0% of the budget remaining. Because the budget to actual variances can be deceiving, please note the following:

Revenues	Actual greater than Budget	Positive Overall Effect
	Actual less than Budget	Negative Overall Effect
Expenses	Actual greater than Budget	Negative Overall Effect
	Actual less than Budget	Positive Overall Effect

Bank reconciliations are completed as follows:

Pooled Cash (Citibank)	thru 4/30/19
Bank of Hemet:	
Payroll	thru 4/30/19
Gas Tax	thru 4/30/19
Workers Comp	thru 4/30/19
Seizure/Evidence	thru 4/30/19
Construction	thru 4/30/19

Trustee Accounts
LAIF

thru 4/30/19
thru 4/30/19

Fiscal Impact:

None.

Finance Director Review:



Recommendation:

1. Receive and file.

City Manager Review:



Attachments:

- A. March 2019 monthly financial reports

Exhibit A



City of Beaumont, CA

PRELIMINARY

GENERAL FUND
Income Statement - Budget to Actual
For the Nine Months and Year to Date 03/31/2019

	Current Total Budget	March 2019 Activity	Year to Date Activity	Variance Favorable (Unfavorable)	% Remaining	FY18-19 Projection
REVENUES						
40 - TAXES	16,980,867.00	698,570.18	10,339,153.43	(6,641,713.57)	-39.11%	16,980,867.00
41 - LICENSES	212,100.00	3,740.10	95,880.56	(116,219.44)	-54.79%	212,100.00
42 - PERMITS	5,397,170.00	266,211.33	4,089,103.43	(1,308,066.57)	-24.24%	5,397,170.00
45 - INTERGOVERNMENTAL	21,288.00	0.00	29,318.92	8,030.92	37.73%	21,288.00
47 - CHARGES FOR SERVICE	7,702,800.00	1,075,962.86	6,130,836.19	(1,571,963.81)	-20.41%	7,702,800.00
50 - FINES AND FORFEITURES	110,000.00	6,814.00	67,503.53	(42,496.47)	-38.63%	110,000.00
53 - COST RECOVERY	0.00	47,424.27	358,749.88	358,749.88	0.00%	0.00
54 - MISCELLANEOUS REVENUES	22,500.00	2,290.92	15,236.80	(7,263.20)	-32.28%	22,500.00
58 - OTHER FINANCING SOURCES	0.00	0.00	24,149.04	24,149.04	0.00%	0.00
TOTAL REVENUES	30,446,725.00	2,101,013.66	21,149,931.78	(9,296,793.22)	-30.5%	30,446,725.00
EXPENSES						
60 - PERSONNEL SERVICES	17,314,871.00	1,951,421.36	12,554,151.87	4,760,719.13	27.5%	17,314,871.00
65 - OPERATING COSTS	17,335,227.40	1,882,679.75	10,955,702.48	6,379,524.92	36.8%	17,335,227.40
70 - CAPITAL IMPROVEMENTS	878,938.36	7,642.37	245,422.92	633,515.44	72.1%	878,938.36
TOTAL EXPENSES	35,529,036.76	3,841,743.48	23,755,277.27	11,773,759.49	33.1%	35,529,036.76
TRANSFERS						
90 - TRANSFERS	5,232,745.00	320,000.00	111,918.53	(5,120,826.47)	-97.9%	5,232,745.00
NET CHANGE	150,433.24	(1,420,729.82)	(2,493,426.96)	(2,643,860.20)	-1757.5%	150,433.24
FY18-19 PROJECTED NET CHANGE	150,433					



City of Beaumont, CA

PRELIMINARY

GENERAL FUND
Comparative Income Statement
For the Nine Months and Year to Date 03/31/2018 and 2019

	2017-2018		2018-2019		March Activity		2017-2018		2018-2019		YTD Variance	
	March 2018	March 2019	March 2019	March 2019	Favorable / (Unfavorable)	Variance %	Year to Date Activity	Year to Date Activity	Favorable / (Unfavorable)	%	Favorable / (Unfavorable)	%
REVENUES												
40 - TAXES	768,569.61	698,570.18	698,570.18	698,570.18	(69,999.43)	-9.11%	9,694,211.41	10,339,153.43	644,942.02	6.65%	644,942.02	6.65%
41 - LICENSES	4,208.75	3,740.10	3,740.10	3,740.10	(468.65)	-11.14%	61,418.32	95,880.56	34,462.24	56.11%	34,462.24	56.11%
42 - PERMITS	281,740.50	266,211.33	266,211.33	266,211.33	(15,529.17)	-5.51%	2,582,178.80	4,089,103.43	1,506,924.63	58.36%	1,506,924.63	58.36%
45 - INTERGOVERNMENTAL	0.00	0.00	0.00	0.00	0.00	0.00%	7,288.01	29,318.92	22,030.91	302.29%	22,030.91	302.29%
47 - CHARGES FOR SERVICE	388,336.83	1,075,962.86	1,075,962.86	1,075,962.86	687,626.03	177.07%	5,598,619.52	6,130,836.19	532,216.67	9.51%	532,216.67	9.51%
50 - FINES AND FORFEITURES	19,964.48	6,814.00	6,814.00	6,814.00	(13,150.48)	-65.87%	70,027.36	67,503.53	(2,523.83)	-3.60%	(2,523.83)	-3.60%
53 - COST RECOVERY	15,749.77	47,424.27	47,424.27	47,424.27	31,674.50	201.11%	245,560.66	358,749.88	113,189.22	46.09%	113,189.22	46.09%
54 - MISCELLANEOUS REVENUES	(124,847.16)	2,290.92	2,290.92	2,290.92	127,138.08	-101.83%	(102,362.13)	15,236.80	117,598.93	-114.89%	117,598.93	-114.89%
58 - OTHER FINANCING SOURCES	0.00	0.00	0.00	0.00	0.00	0.00%	0.00	24,149.04	24,149.04	0.00%	24,149.04	0.00%
TOTAL REVENUES	1,353,722.78	2,101,013.66	2,101,013.66	2,101,013.66	747,290.88	55.20%	18,166,941.95	21,149,931.78	2,992,989.83	16.48%	2,992,989.83	16.48%
EXPENSES												
60 - PERSONNEL SERVICES	1,622,944.02	1,951,421.36	1,951,421.36	1,951,421.36	(328,477.34)	-20.24%	10,542,884.55	12,554,151.87	(2,011,267.32)	-19.08%	(2,011,267.32)	-19.08%
65 - OPERATING COSTS	903,087.65	1,882,679.75	1,882,679.75	1,882,679.75	(979,592.10)	-108.47%	9,508,471.49	10,955,702.48	(1,447,230.99)	-15.22%	(1,447,230.99)	-15.22%
70 - CAPITAL IMPROVEMENTS	14,855.37	7,642.37	7,642.37	7,642.37	7,213.00	48.55%	519,970.12	245,422.92	274,547.20	52.80%	274,547.20	52.80%
TOTAL EXPENSES	2,540,887.04	3,841,743.48	3,841,743.48	3,841,743.48	(1,300,856.44)	-51.20%	20,571,326.16	23,755,277.27	(3,183,951.11)	-15.48%	(3,183,951.11)	-15.48%
TRANSFERS												
90 - TRANSFERS	(17,000.00)	320,000.00	320,000.00	320,000.00	337,000.00	0.00%	(21,611.11)	111,918.53	133,529.64	617.87%	133,529.64	617.87%
NET CHANGE	(1,204,164.26)	(1,420,729.82)	(1,420,729.82)	(1,420,729.82)	(216,565.56)	17.98%	(2,435,995.32)	(2,493,426.96)	(57,431.64)	-2.36%	(57,431.64)	-2.36%



City of Beaumont, CA

PRELIMINARY

WASTE WATER FUNDS
Income Statement - Budget to Actual
For the Nine Months and Year to Date 3/31/2019

	Current Total Budget	March 2019 Activity	Year to Date Activity	Variance Favorable (Unfavorable)	% Remaining	FY18-19 Projection
REVENUES						
47 - CHARGES FOR SERVICE	2,050,000.00	314,756.40	2,726,107.02	676,107.02	33.0%	2,050,000.00
50 - FINES AND FORFEITURES	0.00	500.00	9,000.00	9,000.00	0.0%	0.00
54 - MISCELLANEOUS REVENUES	0.00	0.00	498,325.19	498,325.19	0.0%	0.00
56 - PROPRIETARY REVENUES	8,810,000.00	1,375,593.08	5,820,976.18	(2,989,023.82)	-33.9%	8,810,000.00
58 - OTHER FINANCING SOURCES	90,000,000.00	0.00	8,896,465.88	(81,103,534.12)	-90.1%	90,000,000.00
TOTAL REVENUES	100,860,000.00	1,690,849.48	17,950,874.27	(82,909,125.73)	-82.2%	100,860,000.00
EXPENSES						
60 - PERSONNEL SERVICES	1,155,764.00	146,626.31	541,071.97	614,692.03	53.2%	1,155,764.00
65 - OPERATING COSTS	7,141,120.00	780,147.63	3,738,237.97	3,402,882.03	47.7%	7,141,120.00
70 - CAPITAL IMPROVEMENTS	87,289,750.00	9,962,818.19	15,771,266.40	71,518,483.60	81.9%	87,289,750.00
TOTAL EXPENSES	95,586,634.00	10,889,592.13	20,050,576.34	75,536,057.66	79.0%	95,586,634.00
TRANSFERS						
90 - TRANSFERS	50,000.00	-	3,136,047.00	3,086,047.00	6172.1%	50,000.00
NET CHANGE	5,323,366.00	(9,198,742.65)	1,036,344.93	(4,287,021.07)	-80.5%	5,323,366.00
FY18-19 PROJECTED NET CHANGE	5,323,366.00					



City of Beaumont, CA

PRELIMINARY

WASTE WATER FUNDS
Comparative Income Statement
For the Nine Months and Year to Date 03/31/2018 and 2019

	2017-2018 March 2018	2018-2019 March 2019	March Activity Favorable / (Unfavorable)	Variance %	2017-2018 Year to Date Activity	2018-2019 Year to Date Activity	YTD Variance Favorable / (Unfavorable)	Variance %
REVENUES								
47 - CHARGES FOR SERVICE	60,162.44	314,756.40	254,593.96	423.18%	1,095,331.29	2,726,107.02	1,630,775.73	148.88%
50 - FINES AND FORFEITURES	0.00	500.00	500.00	0.00%	0.00	9,000.00	9,000.00	0.00%
54 - MISCELLANEOUS REVENUES	0.00	0.00	0.00	0.00%	0.00	498,325.19	498,325.19	0.00%
56 - PROPRIETARY REVENUES	(1,147.02)	1,375,593.08	1,376,740.10	-120027.56%	5,348,042.38	5,820,976.18	472,933.80	8.84%
58 - OTHER FINANCING SOURCES	0.00	0.00	0.00	0.00%	0.00	8,896,465.88	8,896,465.88	0.00%
TOTAL REVENUES	59,015.42	1,690,849.48	1,631,834.06	2765.10%	6,443,373.67	17,950,874.27	11,507,500.60	178.59%
EXPENSES								
60 - PERSONNEL SERVICES	38,942.65	146,626.31	(107,683.66)	-276.52%	190,941.66	541,071.97	(350,130.31)	-183.37%
65 - OPERATING COSTS	830,633.69	780,147.63	50,486.06	6.08%	4,576,110.63	3,738,237.97	837,872.66	18.31%
70 - CAPITAL IMPROVEMENTS	1,057.50	9,962,818.19	(9,961,760.69)	-942010.47%	185,260.61	15,771,266.40	(15,586,005.79)	-8413.02%
TOTAL EXPENSES	870,633.84	10,889,592.13	(10,018,958.29)	-1150.77%	4,952,312.90	20,050,576.34	(15,098,263.44)	-304.87%
TRANSFERS								
90 - TRANSFERS	0.00	-	0.00	0.00%	1,303,220.75	3,136,047.00	1,832,826.25	140.64%
NET CHANGE	(811,618.42)	(9,198,742.65)	(8,387,124.23)	1033.38%	2,794,281.52	1,036,344.93	(1,757,936.59)	-62.91%

CITY OF BEAUMONT
Cash Balance Analysis and Reconciliation
For the Nine Months Ending March 31, 2019

Fund	Fund Name	Beginning Cash 06/30/2018	Revenues	Expenses	Fund Transfers	Net Change Assets	Net Adjmts to Equity	Net Change Liabilities	Ending Cash 3/31/2019
	GENERAL FUNDS	8,262,961.20	21,494,387.08	(24,476,385.35)	411,918.53	2,630,745.76	-	(1,448,937.96)	6,874,689.26
	SPECIAL REVENUE FUNDS	10,386,928.17	4,306,914.07	(247,149.83)	(458,747.15)	233,980.44	-	(150,895.89)	14,071,029.81
	CAPITAL FUNDS	36,267,375.48	21,090,858.19	(34,739,397.37)	13,793,024.55	1,306,390.37	-	1,446,205.25	39,164,456.47
	WASTEWATER FUNDS	13,276,268.32	17,950,874.27	(20,050,576.34)	3,136,047.00	(74,436,037.90)	-	74,200,738.13	14,077,313.48
	TRANSIT FUNDS	1,154,061.19	2,732,300.26	(2,691,304.05)	321.66	54,383.25	-	(143,557.02)	1,106,205.29
	AGENCY FUNDS	13,919,790.31	47,844,086.35	(27,175,364.37)	(16,882,564.59)	(80,146,241.68)	-	81,111,380.76	18,671,086.78
	TOTAL FUNDS	83,267,384.67	115,419,420.22	(109,380,177.31)	-	(150,356,779.76)	-	155,014,933.27	93,964,781.09
	Reconciled Balances								
	Pooled Cash - Checking	33,734,678.11							47,126,319.53
	Payroll	2,121,841.14							1,111,410.36
	Workers Compensation	98,510.38							88,609.36
	Gas Tax/Transportation	1,717,530.87							1,611,257.73
	Construction	9,623,238.94							7,477,501.18
	Seizure/Evidence	524,325.75							524,325.75
	LAIF	35,447,259.48							36,025,357.18
	Total Reconciled Balances	83,267,384.67							93,964,781.09

Staff Report

TO: Mayor and City Council Members
FROM: Elizabeth Gibbs, Community Services Director
DATE: May 21, 2019
SUBJECT: Public Hearing: Short Range Transit Plan FYs 2020-2022

Background and Analysis:

The Transportation Development Act (TDA) of 1971 provides funding to be allocated to transit (and non-transit) related purposes that comply with regional transportation plans. Within the TDA, there are two major sources of funding for public transportation:

- (1) the Local Transportation Fund (LTF), which is derived from a ¼ cent of the general sales tax collected statewide; and
- (2) the State Transit Assistance fund (STA), which is derived from the statewide sales tax on diesel fuel.

These funds are for the development and support of public transportation needs that exist in California and are allocated to areas of each county based on population, taxable sales and transit performance.

To ensure program compliance, fiscal and performance audits are conducted. Fiscal audits are conducted annually, and include Beaumont Transit Service's expense-to-revenue ratio, also known as farebox recovery ratio. Performance audits are conducted every three years and include performance measures that verify the efficiency and effectiveness of Beaumont Transit services. Both fiscal and performance audits are generally conducted by auditing firms designated by the Regional Transportation Planning Agency (RTP). In Beaumont's case, the RTP is the Riverside County Transportation Commission (RCTC). The triennial performance audit conducted for FYs 2013-2015 was completed in September 2016 and presented to City Council on December 6, 2016. The audit for fiscal years 2016-2018 is underway and staff met with the auditors on May 3, 2019.

Additionally, compliance of the TDA includes an annual terminal inspection and certification from the Department of the California Highway Patrol indicating that Beaumont Transit Services follows Section 1808.1 of the California Vehicle Code. The 2019 annual terminal inspection is this week and staff fully expects a satisfactory review.

The State Controller's Office (SCO) requires an annual report filed of the transit services operations in accordance with the uniform system of accounts and records adopted by the

SCO. Said report is submitted to RCTC and SCO within 90 days after the close of the fiscal year. The FY 2017-2018 report was filed within the timeframes under the TDA.

As part of the annual program, RCTC requires transit operators to file a Short Range Transit Plan (SRTP) in compliance with the Transportation Development Act. Public participation is a key component of the TDA, with public meetings being held to discuss transportation needs, concerns of the ridership and comprehensive review of the SRTP. The Community Action Committee of RCTC is scheduled to hold a public meeting in the coming weeks to consider this SRTP.

Short Range Transit Plan Highlights:

Funding

The City of Beaumont requested the following funding, as outlined in Table 4 attached to the SRTP document:

- Local Transportation Funds (LTF) - \$2,735,230, and
- State Transit Assistance (STA) - \$2,840,000.

In addition to the above, passenger fare revenues are anticipated in the amount of \$281,000 (farebox recovery).

The current mandated farebox recovery ratio for Beaumont is 10%, based upon our rural population of 48,000. The TDA requires operators with a population of 50,000 or more to meet or exceed a farebox recovery ratio of 20%. This will require a plan of action within the coming years to ensure that the funding allocations and compliance requirements continue to be met.

Planned Service Highlights

Planned services for the next fiscal year as outlined in Table 9 include:

- Adopt an interagency service agreement with the City of Banning for transfer of passengers to Banning buses at connecting points for the intent of eliminating operations in the City of Banning.
- Eliminate one bus on Route 2.
- Add one bus on Commuter Link 120 to increase service and frequency.
- Conduct a Comprehensive Operations Analysis to determine demographics and needs of residents of Beaumont as well as connecting passengers traveling on commuter links.
- Acquire land in an industrial area of Beaumont to build a CNG station, as well as an administration, maintenance and operations facility.
- Procure three cutaway vehicles for replacement.

- Update our branding and logo.
- Install passenger amenities with LCTOP grant funding.
- Continue the travel training program to encourage the use of public transportation.

Summary

Transit dependent residents of the San Gorgonio Pass area rely heavily on the public transit system and we will continue to operate as efficiently and effectively as possible while providing the highest level of customer service to the citizens of Beaumont.

Fiscal Impact:

Beaumont Transit Services is fully funded by various state funding mechanisms and grant resources. There is no fiscal impact to the General Fund.

To that end, revenues and expenditures are reported to RCTC monthly and monitored closely to ensure that the operations are in line with the adopted SRTP and do not exceed LTF and STA funding limits.

Finance Director Review: _____



Recommendation:

1. Open a public hearing and receive input from key stakeholders; and
2. Continue the public hearing to the June 4, 2019 City Council meeting, allowing the community to give input and make recommendations on the draft plan.

City Manager Review: _____



Attachments:

- A. Short Range Transit Plan – Draft
- B. Notice of Public Hearing

City of Beaumont

SHORT RANGE TRANSIT PLAN

FY 2019/20 – 2021/22



TABLE OF CONTENTS

CHAPTER 1 – SYSTEM OVERVIEW	3
1.0 Introduction	3
1.1 Description of Service Area	3
1.2 Population Profile and Demographic Projections	5
1.3 Fixed Route Transit Services and Paratransit Service, Regional Express Bus Service.....	9
1.4 Current and Proposed Fare Structure.....	11
1.5 Revenue Fleet.....	13
1.6 Existing Facility/Planned Facility.....	15
1.7 Existing Coordination Between Transit Agencies	16
CHAPTER 2 - EXISTING SERVICE AND ROUTE PERFORMANCE.....	17
2.1 Fixed Route Service.....	17
2.2 Dial-A-Ride Service.....	31
2.3 Key Performance Indicators	32
2.5 Major Trip Generators and Projected Growth	33
2.6 Equipment, Passenger Amenities and Facility Needs	33
CHAPTER 3 - PLANNED SERVICE CHANGES AND IMPLEMENTATION.....	34
3.1 Recent Service Changes.....	34
3.2 Recommended Service Changes	34
3.3 Marketing Plans and Promotions.....	37
3.4 Budget Impact on Proposed Changes.....	39
CHAPTER 4 – FINANCIAL AND CAPITAL PLANS.....	39
4.1 Operating and Capital Budget.....	39
4.2 Funding Plans to Support Proposed Operating and Capital Program	39
4.3 Regulatory and Compliance Requirements	39

CHAPTER 1 – SYSTEM OVERVIEW

1.0 Introduction

A Short Range Transit Plan (SRTP) is a three year planning document that is updated annually. Its purpose is to evaluate the current transit system and analyze that system for improvements. Capital improvement projects are proposed for funding and operational needs are assessed. The service area, demographics, and operational performance are considered. This document is for the City of Beaumont for Fiscal Year (FY) 2019/2020 and looking ahead to FY 2020/21 and FY 2021/22.

1.1 Description of Service Area

The City of Beaumont's system services approximately 50 square miles and includes the City of Beaumont, the City of Calimesa and parts of unincorporated Riverside County area of Cherry Valley. Additionally, Beaumont transports passengers into the City of Banning and the commercial areas of Cabazon, including Casino Morongo and the Desert Hills Premium Outlet Malls.

At the center of three major thoroughfares, including Interstate 10, Highway 60 and Highway 79, Beaumont offers fixed route, commuter link, and paratransit service. Passengers can connect easily with other Beaumont routes, as well as with regional transit providers such as Banning, Riverside Transit Agency (RTA) and Sunline Transit Agency at one central location, the Beaumont Walmart transit center.

Beaumont operates two Commuter Links to connect Pass Area passengers into San Bernardino County. This express service stops in Beaumont, Calimesa, the San Bernardino Transit Center (SBTC), Kaiser Medical Offices and Loma Linda Veterans Affairs (VA) Hospital. SBTC offers extensive connection possibilities for passengers and includes Metrolink, OmniTrans, Victor Valley Transit Agency (VVTA), RTA and Mountain Transit.

System Map follows:

City of Beaumont
Pass Transit

SYSTEM MAP

Legend
(931) 769-6830
www.ci.beaumont.ca.us

MAP NOT TO SCALE

PASSTRANSIT

- Route 2
- Route 3
- Route 3/4
- Route 4
- Route 7
- Route 8
- Commuter Link 120
- Alternate Route
- Deviation
- Interstate & Highways

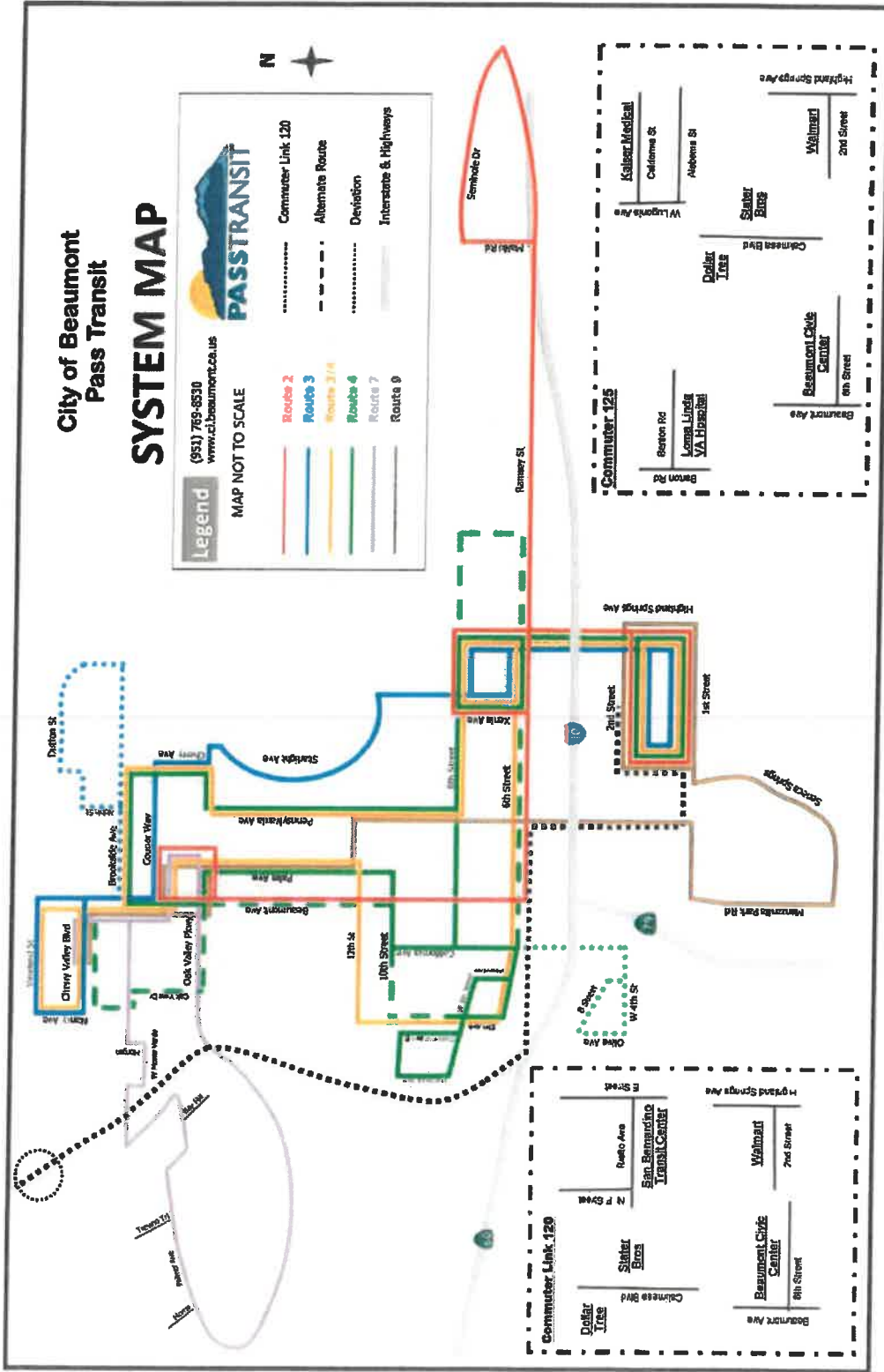

April 2019

1.2 Population Profile and Demographic Projections

According to the most recent report published by California Department of Finance in May 2018, Beaumont is the second fastest growing city in Riverside County; second to our neighbor to the west, City of Calimesa. Beaumont has experienced a 3.2% population increase from January 2017 to January 2018. The California Department of Finance reports Beaumont’s population to be 48,237 in January 2018. There are 15,500 housing units in Beaumont and continues to grow.

Beaumont has 12 schools located within Beaumont Unified School District: 7 elementary, 2 middle, 1 charter, and 2 high schools. Transportation provided by Beaumont Unified School District was eliminated several years ago. Many families rely on public transportation to transport youth passengers to and from school. Youth population (under age 19) in Beaumont is 31%¹; However, ridership reports taken throughout the year show youth passengers make up 56% of total passenger base on Beaumont.

Beaumont has two large active adult communities, with another under construction. There is a reported senior population (persons over the age of 55) of 10,873 persons or 25% of Beaumont’s population². The growing active adult communities and the corresponding increase in population for this age group may impact paratransit and fixed route needs.

Released in May 2018, 2013-2017 American Community 5-year Estimate done by U.S. Census Bureau shows a population of 43,641 and diversity is outlined below:

Demographic	Population Estimation	Percent
RACE		
Total population	43,641	100%
One race	41,453	95%
Two or more races	2,188	5%
One race	41,453	95%
White	29,925	68.6%
Black or African American	2,912	6.7%
American Indian or Alaska Native	302	.7%
Asian	3,603	8.3%
Native Hawaiian or other Pacific	127	.3%
Some other race	4,584	10.5%
Two or more races	2,188	5.0%
White and Black or African	201	.5%
White and American Indian	334	.8%

¹ 2013-2017 American Community Survey 5-year Estimates U.S. Census Bureau

² 2013-2017 American Community Survey 5-year Estimates U.S. Census Bureau

White and Asian	466	1.1%
HISPANIC OR LATINO AND RACE		
Total Population	43,641	100%
Hispanic or Latino	18,592	42.6%
Mexican	15,840	36.3%
Puerto Rican	508	1.2%
Cuban	187	.4%
Other Hispanic or Latino	2,057	4.7%
Not Hispanic or Latino	25,049	57.4%
White alone	17,440	40%
Black or African American alone	2,841	6.5%
American Indian or Alaska Native	145	.3%
Asian alone	3,508	8.0%
Native Hawaiian or other Pacific	117	.3%
Some other race alone	126	.3%
Two or more races	872	2.0%

Ridership Demographics

Ridership surveys conducted in the most recent COA conducted in 2013 show the average passenger to be 21 years of age, 56% of all passengers are female, and Veterans of Armed Forces make up 2% of all passengers.

The following charts are compiled from data collected from 2013 passenger surveys:

Age of Passengers

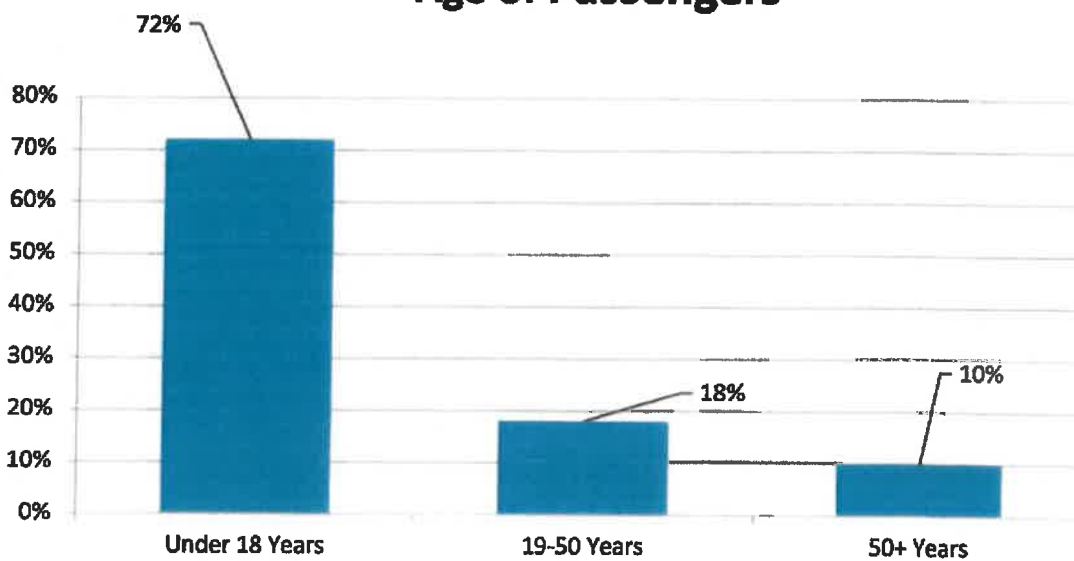

Employment Status

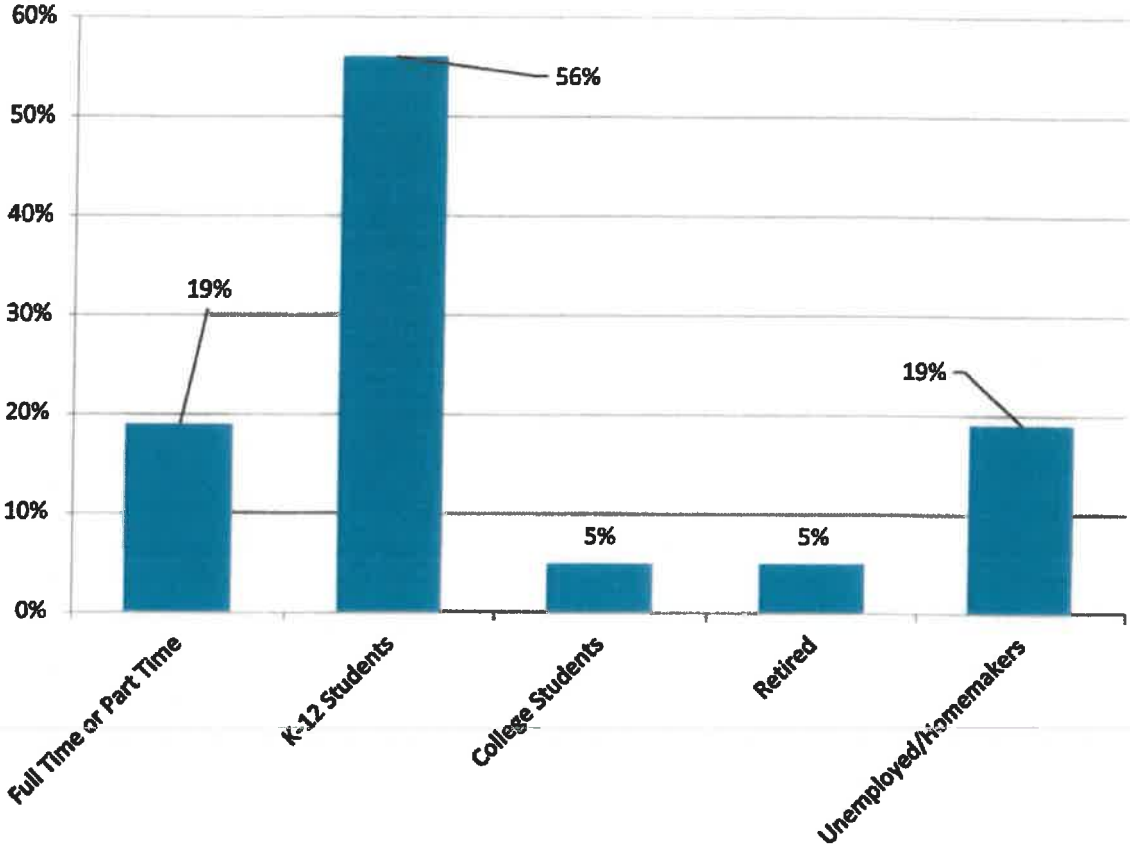

Household Income (Excluding Youth Passenger Data)

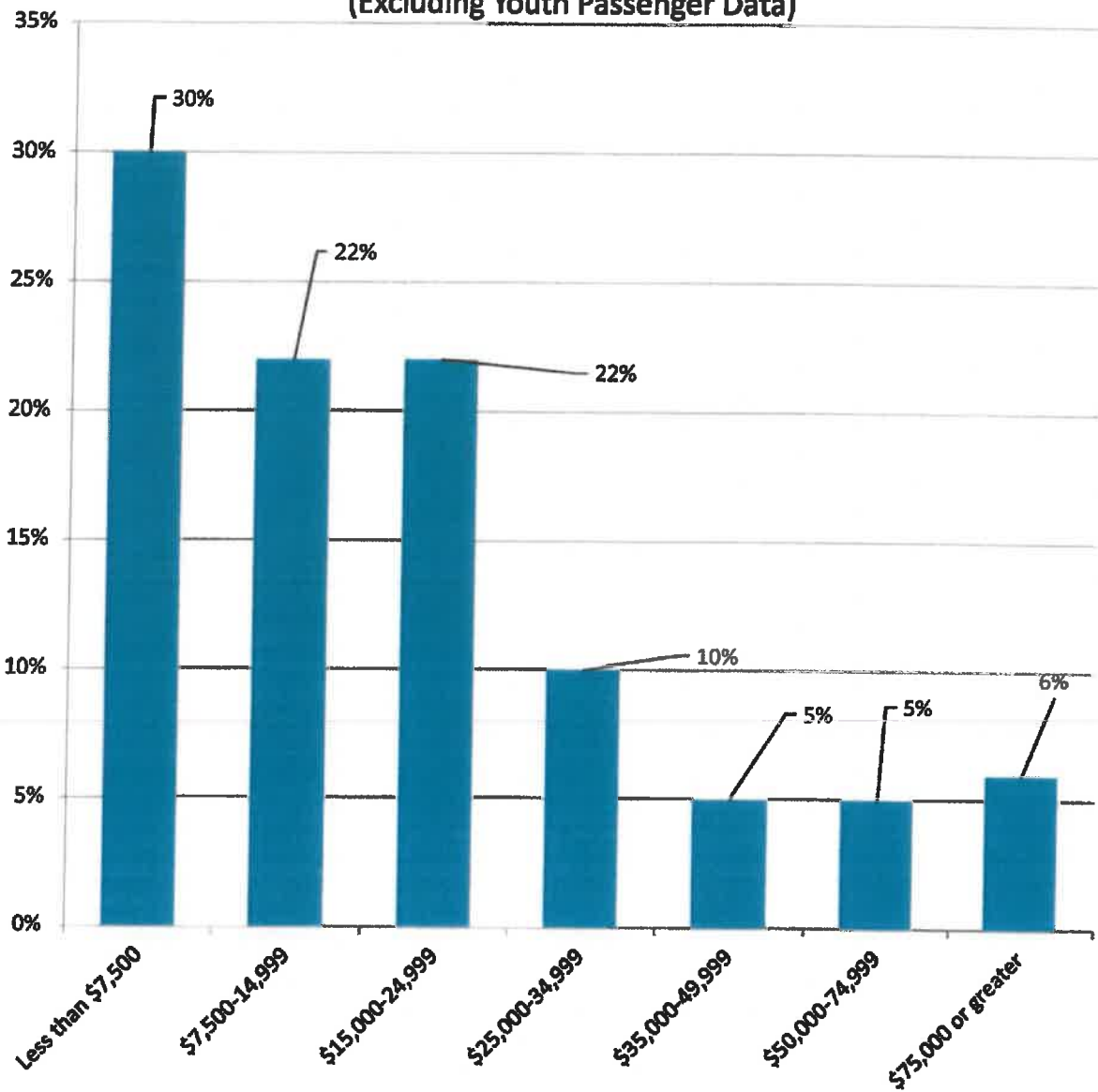

Passenger Ethnicity

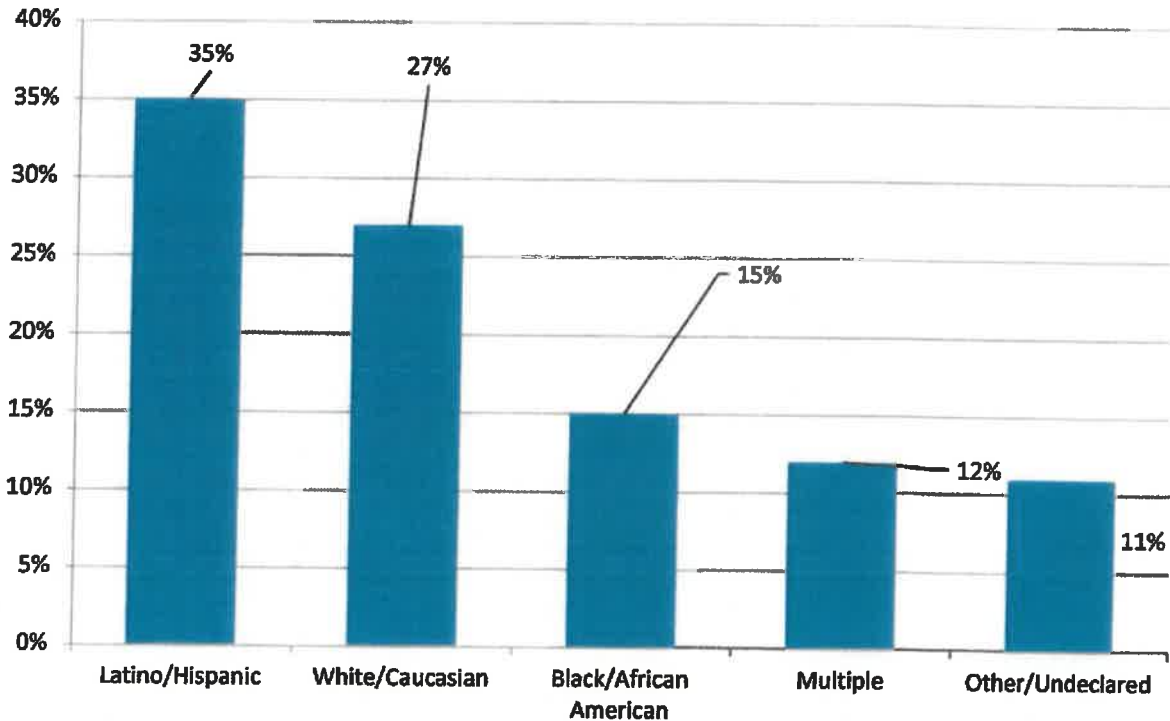

General passengers surveyed indicate 58% do not currently have a driver's license, 55% state they do not have access to an operating vehicle and are transit dependent, and 33% are discretionary riders, have access to a vehicle, and choose to ride public transit because driving is too expensive.

1.3 Fixed Route Transit Services and Paratransit Service, Regional Express Bus Service Beaumont operates seven days a week. Operation schedule is as follows:

<u>Sunday</u>	<u>Monday</u>	<u>Tuesday</u>	<u>Wednesday</u>	<u>Thursday</u>	<u>Friday</u>	<u>Saturday</u>
Route 2	Route 2	Route 2	Route 2	Route 2	Route 2	Route 2
	Route 3	Route 3	Route 3	Route 3	Route 3	
	Route 4	Route 4	Route 4	Route 4	Route 4	
	Route 7*	Route 7*	Route 7*	Route 7*	Route 7*	
	Route 9*	Route 9*	Route 9*	Route 9*	Route 9*	
	CL 120	CL 120	CL 120	CL 120	CL 120	CL 120
	CL 125	CL 125	CL 125	CL 125	CL 125	
						Route 3/4

* Peak Service

Fixed Route

Beaumont operates a total of six fixed routes. Monday – Friday, Route 2 is operated by two buses and Route 7 with three. During the peak of the service weekday, 11 buses are on route.

Fixed route service is projected to show a decrease in FY 19 compared to FY 18, FY 19 is projected to close with 168,950 passenger trips compared to 173,865 in FY 18. This is a 2.91% decrease.

Fixed Route service hours are:

Monday through Friday	6:30 a.m. to 7:26 p.m.
Saturday and Sunday	8:00 a.m. to 6:00 p.m.

During the holidays of Martin Luther King Jr. Day, Presidents’ Day, Columbus Day, Veterans Day, and Day after Thanksgiving, Beaumont operates limited service and follows a Saturday schedule.

Beaumont does not operate on New Year’s Day, Memorial Day, Independence Day, Labor Day, Thanksgiving Day or Christmas Day.

Paratransit Services

Paratransit service, otherwise known as Dial-A-Ride (DAR), is a reservation-based curb to curb service for residents of Beaumont and parts of the unincorporated area of Riverside County, known as Cherry Valley. Qualified passengers include those who reside 3/4 of a mile from a fixed bus route and are certified under American Disabilities Act (ADA). In Beaumont and Cherry Valley, a qualified passenger currently extends to seniors over the age of 65.

DAR service has experienced a decrease in passenger trips in projected FY 19 compared to FY 18. FY 18 had 10,211 passenger trips and FY 19 is projected to end at 9,128 passenger trips. This is a decrease of 11.86%.

DAR service hours are:

Persons with ADA certification

Monday through Friday	6:30 a.m. to 7:00 p.m.
Saturday and Sunday	8:00 a.m. to 6:00 p.m.

Senior *without* ADA certification

Monday through Friday	8:00 a.m. to 4:00 p.m.
-----------------------	------------------------

DAR observes the same holiday schedule as the fixed route system. Limited Service is provided on Martin Luther King Jr. Day, Presidents’ Day, Columbus Day, Veterans Day, and Day after Thanksgiving. No service is provided on New Year’s Day, Memorial Day, Independence Day, Labor Day, Thanksgiving Day, or Christmas Day.

Regional Express Bus Service

Commuter Link 120 was introduced in 2013 and is one of Beaumont’s Regional Express Bus Service. Since 2013, ridership has increased as well as available connections with regional agencies. In 2018, the route was reconfigured to include more frequent service to San Bernardino Transit Center when the Commuter Link 125 was introduced. The CL 120 travels from Beaumont Walmart and Civic Center with stops in Calimesa, and SBTC. At SBTC, passengers can connect with Metrolink, OmniTrans, RTA, Mountain Transit and VVTA.

Commuter Link 120 has grown over the years. Projection of passenger trips in FY 19 is 12,996 and is a 4.94% increase over FY 18 which saw 12,354 trips. It is a 12.73% increase from 11,341 passenger trips made in FY 17.

Commuter Link 125 was introduced in September 2018 and is the second commuter link for regional passenger connections. Service includes Beaumont Walmart and Civic Center with stops in Calimesa, Citrus Plaza (Alabama & Lugonia) in Redlands, Kaiser Medical Offices in Redlands and Loma Linda Veteran’s Affairs (LLVA) Hospital. At these stops, passengers can connect with various OmniTrans routes including SBX and RTA at LLVA. Since September 2018, the Commuter link has an increase in passengers from 347 passenger trips to 481 in March 2019.

Commuter Link service hours are:

Monday through Friday	4:30 a.m. to 8:15 p.m.
Saturday	7:50 a.m. to 6:30 p.m.

1.4 Current and Proposed Fare Structure

In 2018, Beaumont adopted the current fare schedule for two items. 1- increase the cost of 10-ticket books, and 2- add the fare option of commuter link plus local passes. Beaumont has not had a change in the fare schedule since 2012.

Current fare schedule follows:

FARE SCHEDULE

Have exact fare ready when bus arrives. Drivers cannot make change.
NO REFUNDS

FIXED ROUTE FARES

Fare Categories	Base Fare	Day Pass	10 Ride Punch Card	10 Ticket Book	Monthly Pass
General	\$1.15	\$3.00	N/A	\$11.50	\$36.00
Child (46" tall or under) Accompanied by a paying adult	\$.25	N/A	N/A	N/A	N/A
Senior/Disabled (60+)*	\$.65	\$1.80	N/A	\$6.50	\$21.50
Military Veterans*	\$.65	\$1.80	N/A	\$6.50	\$21.50
Deviations (Route 3)	\$.25	N/A	N/A	N/A	N/A
Jury Duty**	FREE	N/A	N/A	N/A	N/A
Go Pass: MSIC students* (During valid school session only)	FREE	N/A	N/A	N/A	N/A
Active Military*	FREE	N/A	N/A	N/A	N/A

COMMUTER LINK FARES

COMMUTER LINK +LOCAL FARES

Fare Categories	Base Fare	10 Ride Punch Card	Day Pass	Monthly Pass
General	\$3.00	\$27.00	\$7.00	\$75.00
Child (46" tall or under) Accompanied by a paying adult	\$2.00	\$18.00	\$5.00	\$50.00
Senior/Disabled*	\$2.00	\$18.00	\$5.00	\$50.00
Military Veterans*	\$2.00	\$18.00	\$5.00	\$50.00
Active Military*	FREE	N/A	N/A	N/A

* If you plan to use a senior, disabled, youth, military or GoPass discounted fare, you must show proper ID each time you board the bus. You must also show proper ID to purchase discounted passes/tickets.

** Jury Duty - All jurors summoned to serve in Banning courthouses are able to ride for free **directly to and from the courthouse via Route 2**. Jurors must show their current and valid juror summons badge to the bus driver.

DIAL-A-RIDE FARES

Fare Categories	Base Fare	10-Ride Punch Card
One-Way	\$2.00	\$18.00
Companion & Child (46" tall or under)	\$3.00	N/A
PCA (w/I.D.)**	FREE	FREE
No Show	\$2.00	N/A

Dial-A-Ride is a transportation service for ADA, disabled and seniors over 65 years of age. Reservations are required at least 24-hours in advance and may be made by calling (951) 769-8532.

**If you plan to use a PCA (Personal Care Attendant) free fare, you must show proper ID each time you board the bus.



Questions? (951) 769-8530

Effective: July 1, 2018

Beaumont Transit continues to explore fare media outlets and in 2018 partnered with Token Transit to offer mobile fare options to Beaumont passengers. Token Transit is a mobile fare app making it easy for passengers to purchase their one way or multi use fare on their smart phones. Many neighboring agencies have begun using this mobile fare option, as has Beaumont Transit, for consistency with passengers.

It is proposed for FY 20 to implement an incremental fare increase to offset increasing operation expenses; while recognizing that our neighboring city fares remain the same.

Proposed fare schedule for FY 20:

FARE SCHEDULE

Have exact fare ready when bus arrives. Drivers cannot make change.
NO REFUNDS

Proposed July 2019

FIXED ROUTE FARES

Fare Categories	Base Fare	Day Pass	10 Ticket Book	Monthly Pass
General	\$1.25	\$3.10	\$12.50	\$39.13
Child (46" tall or under) Accompanied by a paying adult. Limit 2 children at discounted fare.	\$.25	N/A	N/A	N/A
Senior/Disabled (60+)*	\$.75	\$1.90	\$7.50	\$24.80
Military Veterans*	\$.75	\$1.90	\$7.50	\$24.80
Deviations (Route 3 and 4)	\$.50	N/A	N/A	N/A
Go Pass: MSJC students* (During valid school session only)	FREE	N/A	N/A	N/A
Active Military*	FREE	N/A	N/A	N/A

COMMUTER LINK FARES

COMMUTER LINK + LOCAL FARES

Fare Categories	Base Fare	10 Ride Punch Card	Day Pass	Monthly Pass
General	\$3.50	\$31.50	\$8.00	\$75.00
Child (46" tall or under) Accompanied by a paying adult	\$2.50	\$22.50	\$6.00	\$50.00
Senior/Disabled*	\$2.50	\$22.50	\$6.00	\$50.00
Military Veterans*	\$2.50	\$22.50	\$6.00	\$50.00
Active Military*	FREE	N/A	N/A	N/A

* If you plan to use a senior, disabled, or military discounted fare, you must show proper ID each time you board the bus. You must also show proper ID to purchase discounted passes/tickets.

* Go Pass passengers must have a valid sticker on their school ID to board at no charge.

DIAL-A-RIDE FARES

Fare Categories	Base Fare	10-Ride Punch Card
One-Way	\$2.00	\$18.00
Companion & Child (46" tall or under)	\$3.00	N/A
PCA (w/LD.)**	FREE	FREE
No Show	\$2.00	N/A

Dial-A-Ride is a transportation service for ADA, disabled and seniors over 65 years of age. Reservations are required at least 24-hours in advance and may be made by calling

**If you plan to use a PCA (Personal Care Attendant) free fare, you must show proper ID each time you board the bus.



Questions? (951) 769-8530

Proposed July 2019

1.5 Revenue Fleet

Fleet Characteristics

Beaumont consists of nineteen (19) vehicles. Fifteen (15) are cutaways, three (3) 40-foot buses and our newest addition is a 32-foot EZ Rider II CNG bus.



Of the nineteen (19) vehicles, ten (10) are fueled by Compressed Natural Gas (CNG); the other nine (9) are gasoline fueled. All recent and future bus purchases are powered by CNG, as is RCTC's policy. All vehicles are outfitted with bike racks and are ADA compliant with wheelchair lifts and tie down stations. Three (3) buses have audio announcement systems for the visually impaired. Fourteen (14) are equipped with passenger seatbelts.

Nineteen (19) vehicles are made up as follows:

- Six (6) are Ford E-450 16 passenger buses
 - o Five (5) are gasoline powered; One (1) is CNG
- Five (5) are Ford F-550 30 passenger buses
 - o Three (3) are gasoline powered; Two (2) are CNG
- Four (4) are C-5500
 - o One (1) gasoline powered; Three (3) CNG
- Three (3) are XHF-40 powered by CNG
- One (1) EZ Rider II powered by CNG

1.6 Existing Facility/Planned Facility

Existing Facility

The Administrative services for the Beaumont Transit Department are in the heart of downtown Beaumont and located at the Beaumont Civic Center, 550 E 6th Street, Building D. It is at this location where dispatch, administrative assistance, and the operations yard are located. The

Fleet maintenance service is located at 550 California Ave, approximately 1 mile from the administrative building.

Customer service calls for general information, route planning, and Dial-A-Ride appointments are completed by the Transit Department in Building D. Walk in customers, including the purchase of fare media, are completed at City Hall.

Planned Facility

Administration, Fleet Maintenance and Operations have outgrown our facilities. Buses and other resources are located at separate locations creating a disconnect. Currently, Beaumont is actively pursuing the purchase of property in the industrial area of Beaumont. It is proposed to build an administrative, fleet maintenance and operations facility at this location. This location will also contain a public CNG Station with plans to expand to an electric vehicle charging station for our growing fleet. The State of California's goal is to transition to 100% zero-emission bus fleets by 2040. It is Beaumont's intention to prepare to meet this goal by replacing gas buses, as it becomes necessary, with electric vehicles.

Design and construction of a CNG station is the primary focus. For too many years, Beaumont has been without a CNG station to fuel its fleet. In FY 18, after some long-awaited remodeling and repairs to the only CNG station in Beaumont, owned and operated by Beaumont Unified School District, Beaumont CNG buses can fuel there within specific hours Monday through Friday. Although we can fuel locally during specific hours, it is still necessary to drive our fleet to other locations to fuel, which include a one-way trip of 14.6 miles to the RTA fueling station in the city of Hemet. Another location is 18.3 miles away in the city of Moreno Valley. Our last option for CNG fuel is in the city of Redlands located 17.6 miles away.

1.7 Existing Coordination between Transit Agencies

Because of geographical isolation, coordination is vital for the movement of passengers. Passengers traverse cities to accomplish needs such as social services in Banning as well as shopping in Beaumont. Beaumont has implemented multiple agreements with surrounding transit operators, including OmniTrans, RTA, and Victor Valley Transit Authority (VVTA). Beaumont intends to enter into an interagency service agreement with the City of Banning effective July 1, 2019. With this new agreement, the current Cooperative Services Agreement from 2001 will be terminated, thereby terminating the "Pass Transit" branding.

As Beaumont expands service to critical connection areas such as SBTC, interagency service agreements have become more prevalent and necessary. Agreements with OmniTrans, RTA and VVTA have added value for connecting passengers.

- Passengers presenting a Beaumont multi use (day or month) pass can connect to OmniTrans, RTA or VVTA for free wherever the two agencies connect.
- Passengers presenting a multi use (day, week or month) pass from OmniTrans or VVTA receive a \$1.00 discount on commuter service or free connection with our fixed route wherever we connect.

- Passengers presenting RTA multi use pass (day, week or month) connect for free to Beaumont's commuter and fixed route service wherever the two agencies connect.

It is Beaumont's hope that having an interagency service agreement with Banning will allow Pass area transit dependent residents to move about the region in a seamless manner, without an increase in cost from our current fare structure.

CHAPTER 2 - EXISTING SERVICE AND ROUTE PERFORMANCE

Overall systemwide passenger trips in FY 19 is projected to remain consistent with FY 18 systemwide passenger trips. In FY 18, Beaumont system serviced 196,430 passenger trips. In FY 19 projected systemwide passenger trips is anticipated to close at 196,932 trips. Beaumont offers three types of service: fixed route, commuter, and paratransit. In FY 19, Fixed Route service accounts for 86.68% of total passenger trips, 8.78% for commuter and 4.53% for paratransit.

2.1 Fixed Route Service

Beaumont system operates six fixed routes, using nine buses.

Route 2 -Beaumont to Cabazon

Beaumont's trunk route is Route 2 and has two-hour headway from Beaumont to Cabazon. Weekday service is achieved by two buses, referred to internally as Route 2-1 and 2-2. Both Saturday and Sunday have one bus on the route. This route services many low-income apartment complexes and brings passengers to major places of interest such as commercial, grocery, social services, the courthouse, DMV, and employment opportunities.

Route 2 has experienced an increase in passenger trips compared to FY 18. March 2019, YTD, Route 2 had 56,344 passenger trips. This is an 8.49% increase of 51,561 passenger trips in FY 18. Compared to FY 17 YTD passenger trips, which was 54,551, Route 2 has an increase of 3.18%. Route 2 makes up 38.94% of all passenger trips system wide and averages 10.59 passengers transported per revenue hour.

ROUTE 2

Beaumont to Cabazon
Effective December 1, 2017

Info: (951) 769-8530
Beaumont.doublemap.com
www.passtransit.com

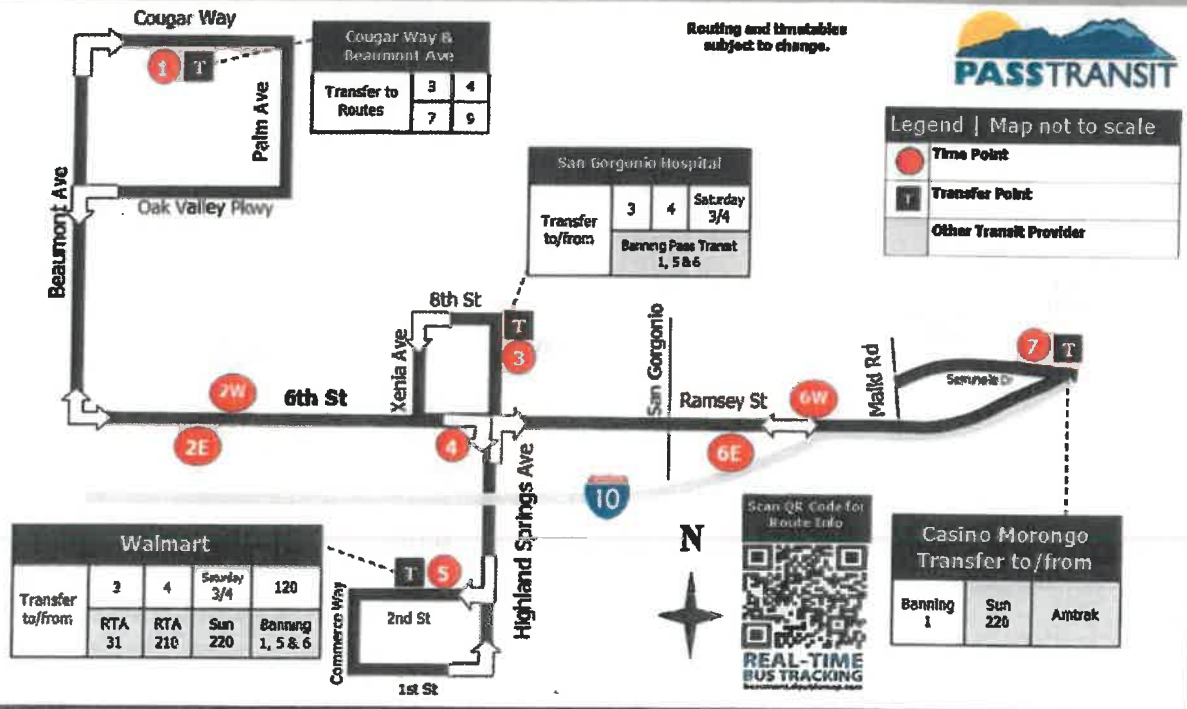

Route 3 - Beaumont High School to Walmart via Sundance

Route 3 is a weekday one-hour headway servicing north area of Beaumont including parts of Cherry Valley to Walmart via the easternmost residential community commonly known as Sundance. It also has a deviation built into the route for those living outside City of Beaumont city limits, in Cherry Valley, north of Brookside Ave.

Route 3 has experienced a decline in passenger trips over the years. March 2019, YTD, Route 3 had 17,261 passenger trips. This is a 16.91% decline over the 20,179 passenger trips in FY 18. Compared to FY17 YTD passenger trips, which was 22,991, Route 3 has showed a 33.20% decline. Route 3 currently makes up 12.24% of total system wide passenger trips and averages 8.95 passengers transported per revenue hour.

ROUTE 3 WEEKDAY SERVICE (Except Holidays)

Beaumont, Cherry Valley to Walmart via Sundance

Effective December 1, 2017

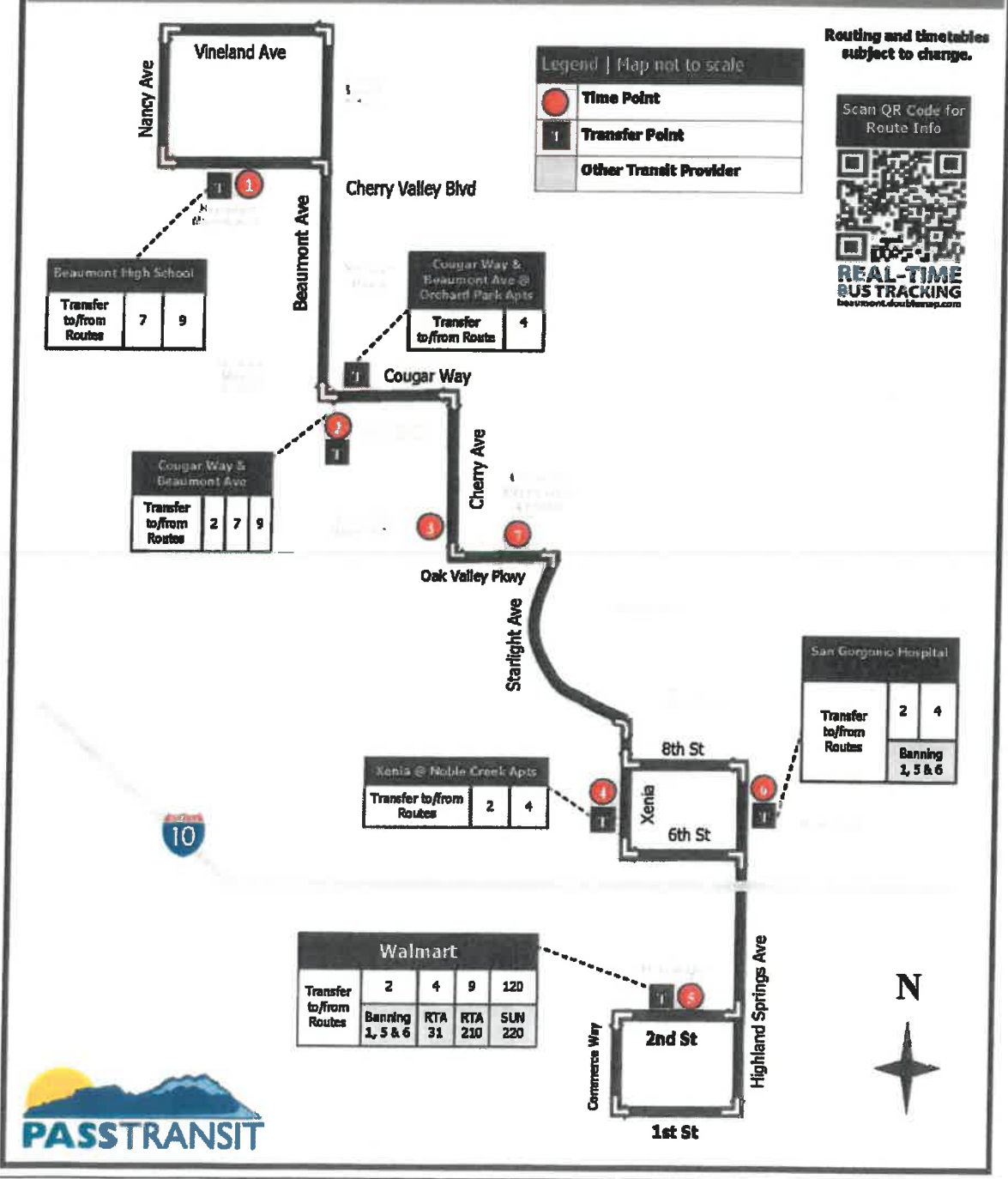

Route 4 - Downtown to Walmart

Route 4 is a weekday one-hour headway route which runs primarily east to west via downtown residential areas. The route connects passengers with the local library, two elementary schools, a community center, both middle schools and the commercial shopping area of Walmart. A deviation is also available to the residential and industrial area south of Interstate 10.

Route 4 has experienced a slight decline in passenger trips over the years. March 2019, YTD, Route 4 had 17,794 passenger trips. This is a .31% decline over the 17,849 passenger trips in FY 18. Compared to FY17 YTD passenger trips, which was 18,378, Route 4 has showed a 3.28% decline. Route 4 currently makes up 12.54% of total system wide passenger trips and averages 8.24 passengers transported per revenue hour.

ROUTE 4 WEEKDAY SERVICE (Except Holidays)

Downtown via 3 Rings Ranch and Walmart

Effective December 1, 2017

Routing and timetables subject to change.

Legend | Map not to scale

- Time Point
- Transfer Point
- Other Transit Provider
- Alternate Morning Route

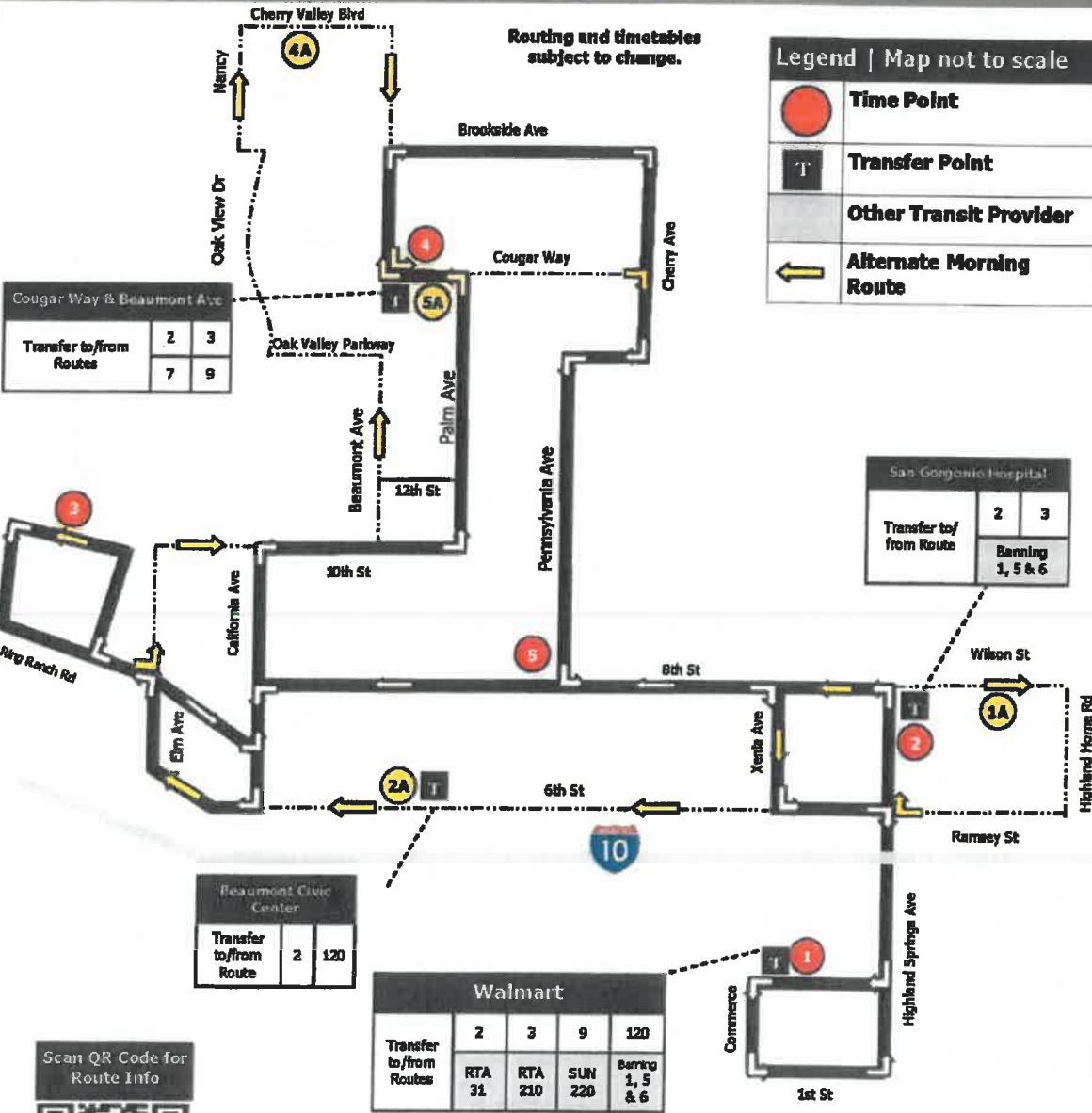

Cougar Way & Beaumont Ave

Transfer to/from Routes	2	3
	7	9

San Geronimo Hospital

Transfer to/from Route	2	3
	Berring 1, 5 & 6	

Beaumont Civic Center

Transfer to/from Route	2	120
------------------------	---	-----

Walmart

Transfer to/from Routes	2	3	9	120
	RTA 31	RTA 210	SUN 220	Berring 1, 5 & 6

Scan QR Code for Route Info



REAL-TIME BUS TRACKING
beaumont.doublemap.com



Route 7- Tournament Hills/Fairway Canyon to Beaumont High School

Route 7 is a weekday peak hour service. This route was designed to service passengers during the peak hours of morning and afternoon between the westernmost residential areas of Beaumont, both middle schools, and high school. There are two buses on this route, which we internally refer to as Route 7-1 and 7-2. There is also an afternoon tripper for the peak hours.

Route 7 has experienced a decline in passenger trips over the years. March 2019, YTD, Route 7 had 22,568 passenger trips. This is a 15.23% decline over the 26,005 passenger trips in FY 18. Compared to FY17 YTD passenger trips, which was 24,497, Route 7 has shown an 8.55% decline. Route 7 currently makes up 15.74% of total system wide passenger trips and averages 28.68 passengers transported per revenue hour.

ROUTE 7

WEEKDAY SERVICE | Tournament Hills & Fairway Cyn
(when school is in session)

Routing and timetables
subject to change.

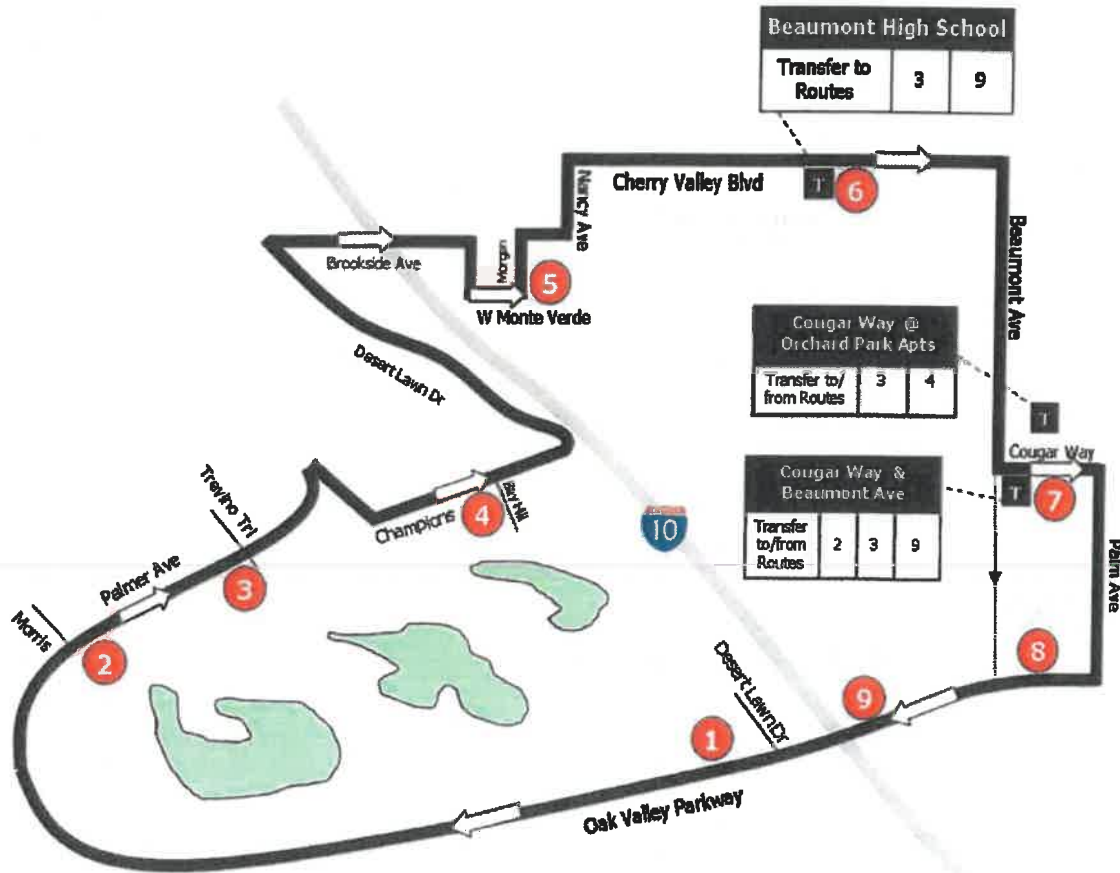

Scan QR Code for
Route Info



**REAL-TIME
BUS TRACKING**
beaumont.doublemap.com

Legend | Map not to scale

	Time Point
	Transfer Point
	Afternoon bus from BHS



Route 9 - Seneca Springs to Beaumont High School

Route 9 is a weekday peak hour service and was designed to service passengers during the peak morning and afternoon hours between Beaumont's southeast residential area, both middle schools, and high school.

Route 9 has experienced a decline in passenger trips over the years. March 2019, YTD, Route 9 had 8,694 passenger trips. This is a 23.71% decline over the 10,775 passenger trips in FY 18. Compared to FY17 YTD passenger trips, which was 8,585, Route 9 has showed an 1.25% increase. Route 9 currently makes up 6.0% of total system wide passenger trips and averages 13.05 passengers transported per revenue hour.

ROUTE 9

WEEKDAY SERVICE (when school is in session)
Seneca Springs

Routing and timetables
 subject to change.

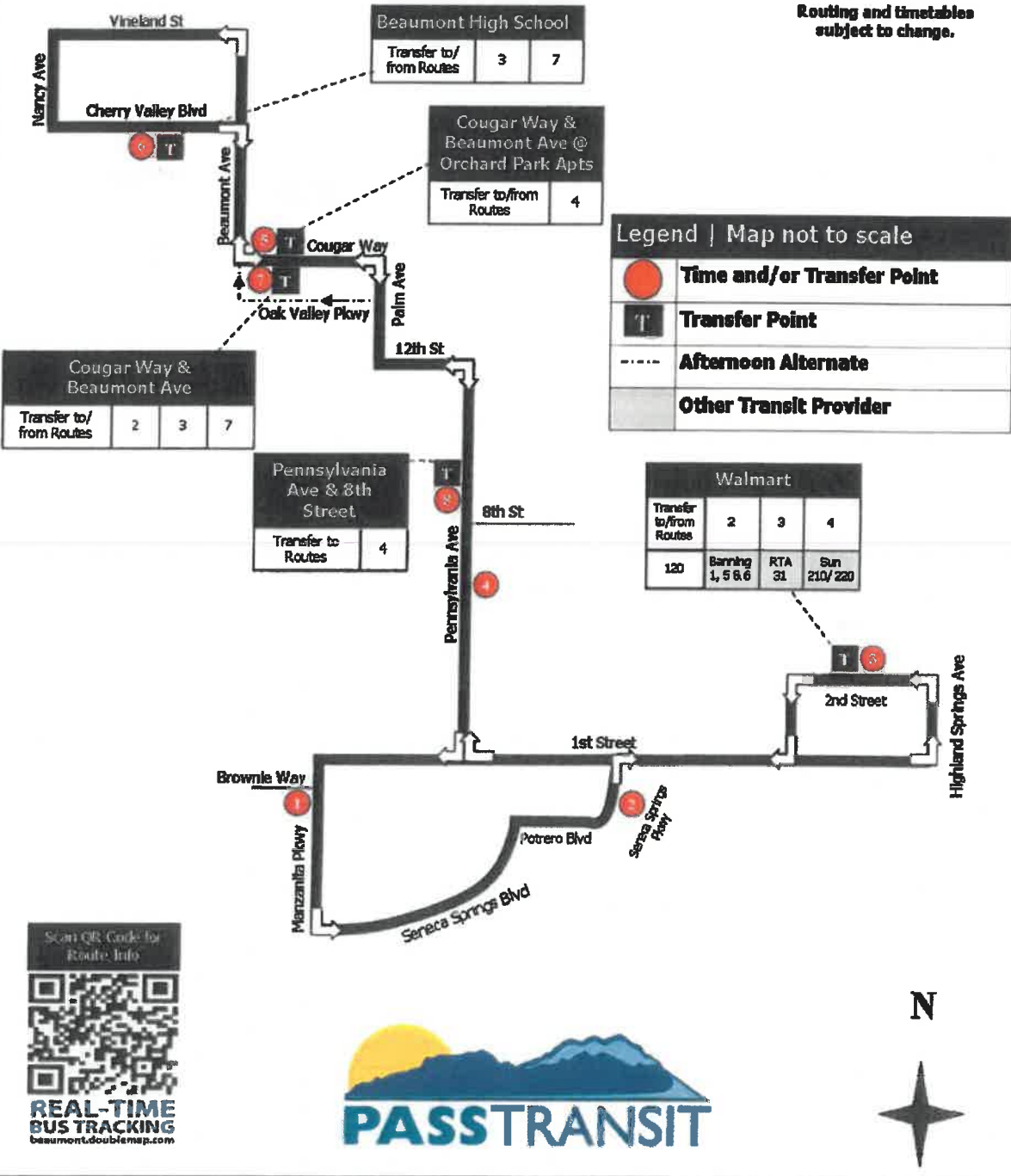

Route 3/4 – Saturday service from Cherry Valley to Walmart

Route 3/4 is a one-hour headway service and offers Saturday service as well as limited service on recognized holidays. It is a combination route of Routes 3 and 4.

Route 3/4 has experienced an increase in passenger trips over the years. March 2019, YTD, Route 3/4 had 2,121 passenger trips. This is a 2.64% increase over the 2,065 passenger trips in FY 18. Compared to FY17 YTD passenger trips, which was 1,973, Route 3/4 has shown a 6.98% increase. Route 3/4 currently makes up 1.41% of total system wide passenger trips and averages 4.97 passengers transported per revenue hour.

ROUTE 3/4 Saturday Service

Cherry Valley, Beaumont to Walmart

Effective January 7, 2017

Routing and timetables subject to change.

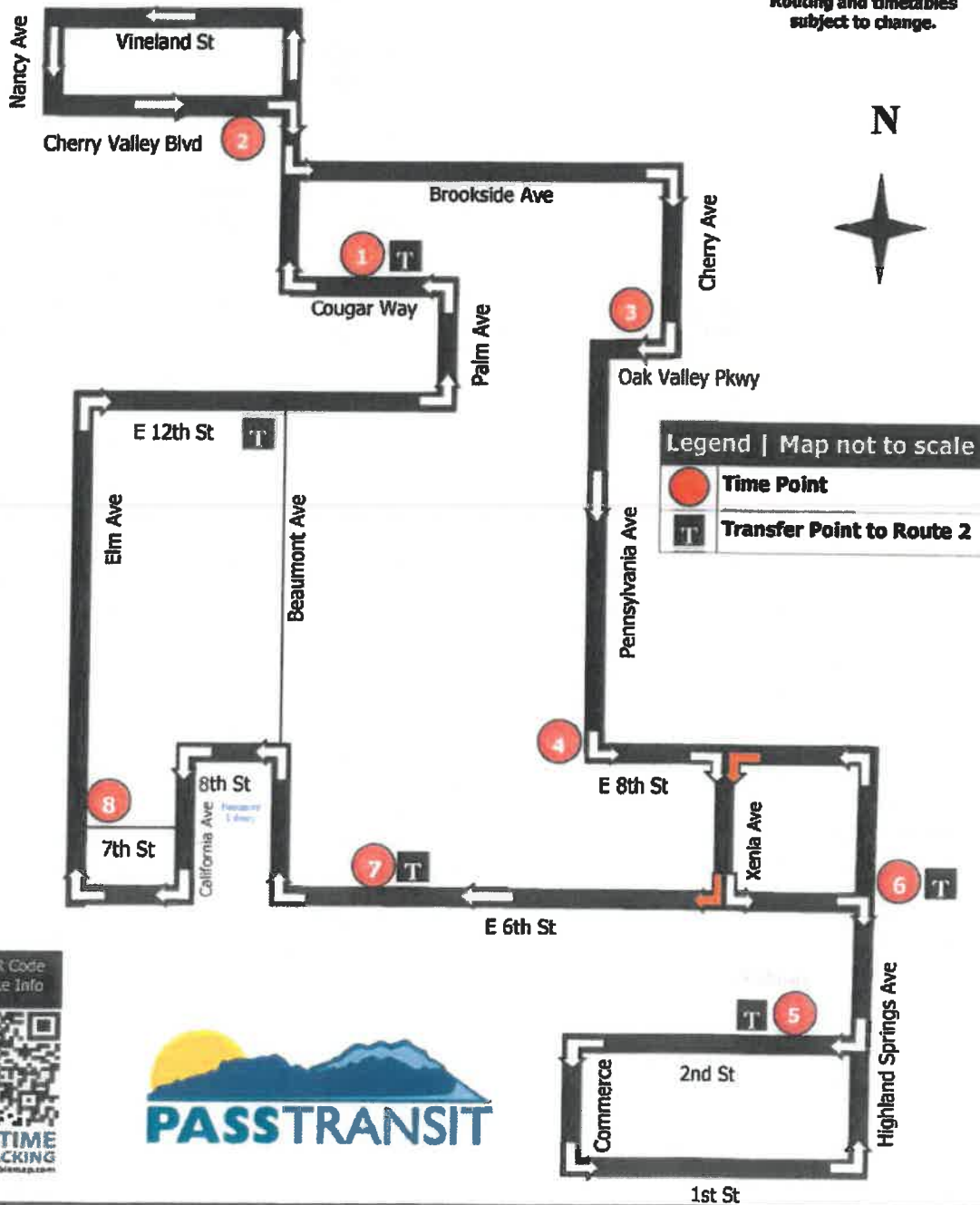

Commuter Link 120

Commuter Link 120 is an express commuter service connecting the Pass Area with San Bernardino County. Originating at Beaumont Walmart, this express service stops at the Beaumont Civic Center, Calimesa, and San Bernardino Transit Center.

Route 120 has remained flat in FY 19 over FY 18 but shows an increase when compared to FY 17 YTD. March 2019, YTD, Route 120 had 9,300 passenger trips. This is a .6% decline over the 9,356 passenger trips in FY 18. Compared to FY17 YTD passenger trips, which was 8,716, Route 120 has showed an increase of 6.28% decline. Route 120 currently makes up 6.47% of total system wide passenger trips and averages 3 passengers transported per revenue hour.

COMMUTER LINK 120

Beaumont, Calimesa to San Bernardino Transit Center
Effective October 15, 2018

Monday—Friday and Saturday Service (Except Holidays)

Routing and timetables
 subject to change.



San Bernardino Transit Center

2nd Street

Rialto Ave **T** **4**

TRANSIT CENTER



Legend | Map not to scale

- Time Point
- Transfer Point

www.passtransit.com



Calimesa

120



County Line Road

Myrtlewood Dr

Calimesa Blvd **T** **5**

3 **T**

Beaumont Walmart

1, 2, 3, 4, 9, 125 and Combo

31

Wells Fargo

2



Magnolia Ave

6th Street **T** **6**

2 **T**

Beaumont Civic Center

2

Walmart

1 **T**

2nd Street

Highland Springs Ave

BEAUMONT CIVIC CENTER (PARK & RIDE)

Commuter Link 125

Commuter Link 125 was introduced in September 2018 and is also an express commuter service connecting the Pass Area with San Bernardino County. Originating at Beaumont Walmart, this express service stops at the Beaumont Civic Center, Calimesa, Citrus Grove Plaza (Alabama & Lugonia Ave) in Redlands, Redlands Kaiser Medical Offices and Loma Linda Veterans Affairs Hospital.

Commuter Link 125 is a new commuter link which started in September 2018. It has experienced an increase in passenger base from 347 passenger trips in its first month and has shown a gradual increase to 469 passenger trips in March 2019.

COMMUTER LINK 125

Beaumont, Calimesa, Citrus Plaza @ Alabama/Lugonia,
Kaiser Redlands Medical Offices, Loma Linda VA Hospital
Effective October 15, 2018

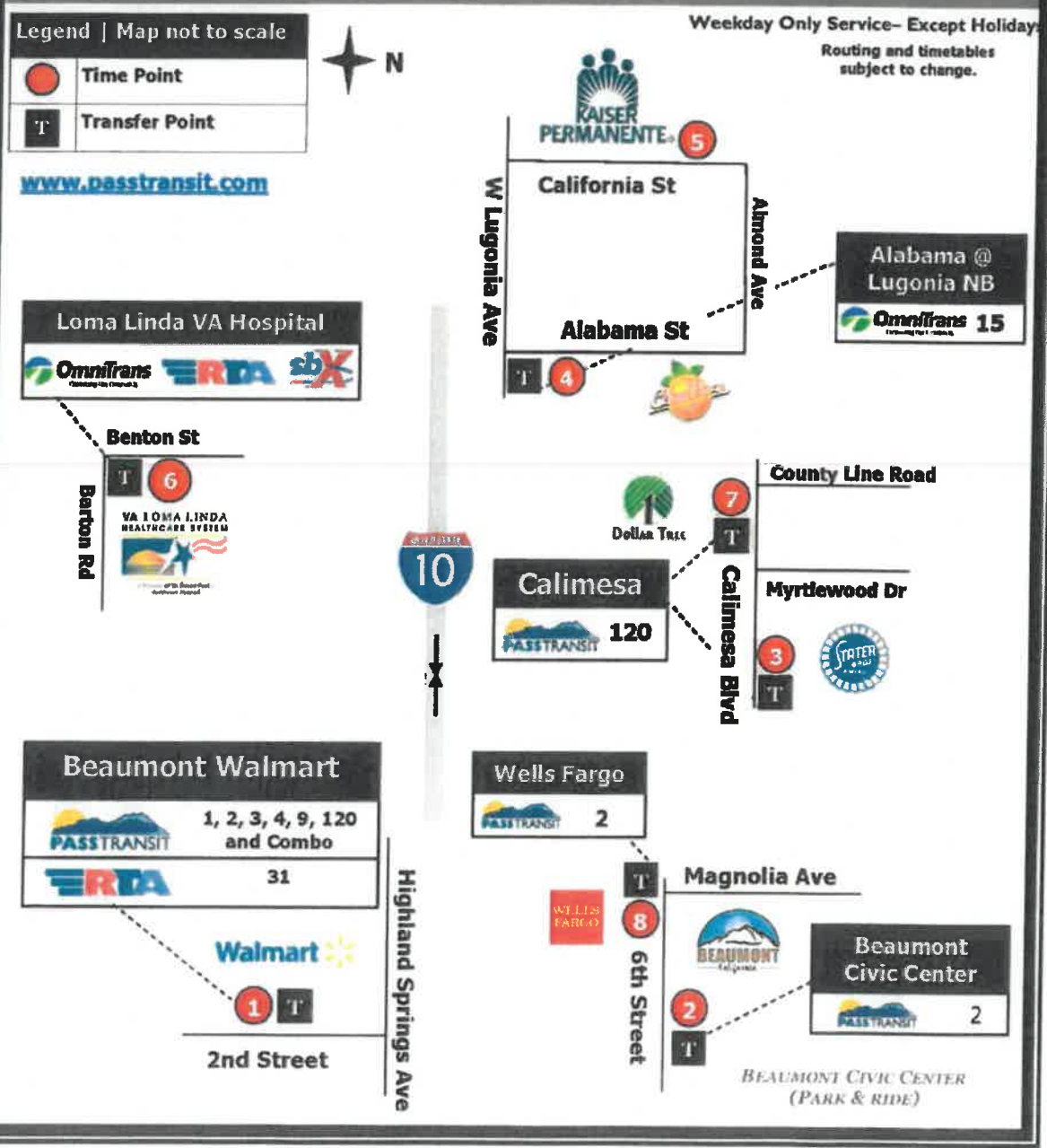

2.2 Dial-A-Ride Service (DAR)

DAR is made up of two buses and is a reservation-based system. This curb to curb service is a complimentary service to our fixed route system and is available to qualified passengers. Service is provided for persons with ADA certification in the cities of Beaumont and parts of Cherry Valley who live 3/4 of a mile from a fixed bus route. Certification is obtained through the ADA application process with RTA. Additionally, this service is also available for persons over the age of 65. Projected passenger trips in FY 19 is 9,128 and is a 11.89% decrease compared to FY 18 which had 10,211 passenger trips.

2.3 Key Performance Indicators

Riverside County Transportation Commission adopted a Productivity Improvement Plan (PIP) for the transit operators of Riverside County. Although compliance with PIP is no longer required, it is used for monitoring and service improvement to improve efficiency. Beaumont's performance indicators are shown in Tables 7 and 8.

2.4 Productivity Improvement Efforts

Beaumont uses several products to keep passengers connected with system information and announcements. These products are Facebook, Double Map (a web based real time GPS bus locating system), Google Transit, and Everbridge (a mass communication system operated in conjunction with Beaumont Police Department).

Pass Area residents are invited to attend travel training trips led by the staff of Beaumont. Destinations include Los Angeles Union Station, Downtown Disney, and Oceanside.—The purpose of travel training is to empower the public with strategy and knowledge of local transit system, as well as other regional connecting systems such as Metrolink, RTA and Metro. Education of public transit, by means of travel training informational meetings and outings, will assist in the alleviation of common fears surrounding public transit and get passengers comfortable with moving around and using public transportation.

Beaumont has received a grant from Low Carbon Transit Operations Program (LCTOP) for Free Fare Promotion on Beaumont buses which has been extended to Banning Transit for March 1-May 17, 2019 implementation. This Free Fare Promotion has shown an increase in passenger trips in March 2019 over March 2018. Beaumont transit system saw 19,677 passenger trips in March 2019 over the 17,154 passenger trips made in March 2018. This is a 12.82% increase.

To help our system grow, Beaumont intends to conduct a Comprehensive Operations Analysis (COA). A COA was last conducted in 2013 and although it was not formally adopted, parts of its analysis were implemented, including the addition of a second bus on Route 2 and the expansion of the route to Cabazon via Ramsey Street in Banning. The purpose of the 2019 COA will be to determine demographics and needs of the residents of Beaumont, as well as connecting passengers traveling into and out of the city via our commuter links. An analysis of our growing city and our increased residential, commercial and industrial areas will require the implementation of new routes and route design. COA professionals will be crucial to the connectivity of routes and determining service needs to better service passengers in the area.

2.5 Major Trip Generators and Projected Growth

More than half of Beaumont's passengers attend BUSD schools. They are primarily traveling to and from home and high school/middle schools. This clientele is expected to increase as the population and housing continues to grow. Current increases in Routes 7 and 9 are largely due to this factor. To service a larger audience of this category, peak hour services have been adjusted. There will be no added buses for peak service in FY 20. Peak oriented service costs more to provide than all-day service because they require additional vehicles and drivers which are not utilized to their full potential³.

The City of Beaumont continues to grow with 450 more homes planned for FY 20. Beaumont Transit is challenged with the opportunity to grow with the population. Our population is currently reported to be 48,237 by the California Department of Finance. As it quickly approaches 50,000, Beaumont will soon be in the urban category, therefore requiring 20% farebox recovery ratio within five years, as mandated by the Transportation Development Act (TDA). Homes are being built in previously vacant land areas. Routes will be created or adjusted based on the need for service in the various areas, as determined in the COA.

Beaumont offers two commuter services to connect passengers to San Bernardino County and beyond. Commuter Link 120 has been in service since 2013 and Commuter Link 125 was introduced in September 2018. Both commuters have grown in passenger trips month over month and are widely popular with inquiries from traveling passengers on Metrolink and other regional providers connecting to Beaumont and Casino Morongo.

2.6 Equipment, Passenger Amenities and Facility Needs

A continuous look at our future and the amenities needed to grow our system, show a need for replacement of vehicles. Six of our nineteen vehicles are over at or approaching 10 years old; another four are nine years old. Funding for replacement will be necessary in the coming years. Delivery time of one year from date of approved purchase is a normal experience for bus procurement in Beaumont. At least three buses are nearing retirement and are considered for replacement. Capital funding request is submitted in Table 4 for replacing these retiring vehicles.

Twenty-two (22) shelters have been installed in Beaumont. Half of them are prominently in commercial areas serviced by Route 2. The other half are located in high ridership areas such as high-density residential areas and schools. There are also a dozen benches strategically placed in Beaumont service system. Benches have also been installed in the city of Calimesa at critical commercial areas where passengers connect with Commuter Links 120 and 125.

Beaumont has applied for a Low Carbon Transit Operation Program (LCTOP) grant to improve three bus stop locations popularly used by connecting passengers. Included are bus stops located at the Beaumont Library, as well as the Wells Fargo location located on 6th Street serviced by Commuter Links and Route 2. Beaumont Walmart will also be rehabilitated with landscaping,

³ TMD, Comprehensive Operations Analysis City of Beaumont Service Recommendations, June 2014.

benches information kiosks and other amenities to increase transit visibility and passenger comfort to the hundreds of passengers connecting at this location daily.

Included in Table 4 is a capital request for a re-branding and logo update. Needed in the coming fiscal years is the revamping of the system signage including bus stop signs, schedule holders and bus graphics. Bus stop signs, originally installed in early 2000's, have become faded and invisible to untrained eyes. Repurposed from RTA, schedule holders were donated, installed and are currently in use in Beaumont since 2010. These schedule holders have become increasingly difficult to maintain as graffiti and vandalism are often the case. Beaumont intends to update our logo to include a new design and move away from the Pass Transit brand. Current graphics on buses are weathered, oxidized and peeling. To implement the new branding, graphics on buses will be updated.

As discussed in section 1.6, Planned Facility, Beaumont needs consolidated and enlarged administrative, vehicle maintenance and operations facility in conjunction with CNG and future electric charging station.

CHAPTER 3 - PLANNED SERVICE CHANGES AND IMPLEMENTATION

3.1 Recent Service Changes

September 2018 brought about changes to our Commuter Link system. With the introduction of Commuter 125, the Commuter 120 route and schedule was analyzed and adjusted to increase service, frequency and reliability. Public comments and analysis determined there are two regional transportation needs. One is for commuting, as offered on Commuter 120 and the other for medical services, offered on Commuter 125.

Commuter 125 was designed to relieve the Loma Linda Veterans Hospital from the Commuter 120 which travels to the San Bernardino Transit Center. Commuter 125 travels to Redlands and Kaiser Medical offices in Redlands and continues to the Loma Linda Veterans Hospital. This enables Commuter 120 to increase its frequency traveling only to San Bernardino Transit Center from Beaumont and Calimesa.

3.2 Recommended Service Changes

FY 20 will bring significant service changes to the Beaumont system. At Banning's request, Beaumont will no longer operate Route 2 in the City of Banning. Pending the approval of an Interagency Service Agreement with Banning, Beaumont will cooperate with Banning in transferring passengers at Walmart and San Geronio Hospital without an additional fare to the passenger. It is Beaumont's intent to provide adequate and timely service to the transit dependent passengers within Beaumont that need social services primarily located along Banning's Ramsey in the City of Banning.

In FY 20, Route 2 will operate with a single bus and operate on a 1-hour headway. Weekends it will extend its service to Casino Morongo and Outlet Mall via I-10 freeway.

ROUTE 2

Beaumont- Cougar Way to Walmart

Proposed Effective July 1, 2019

Info: (951) 769-8530

Beaumont.doublemap.com

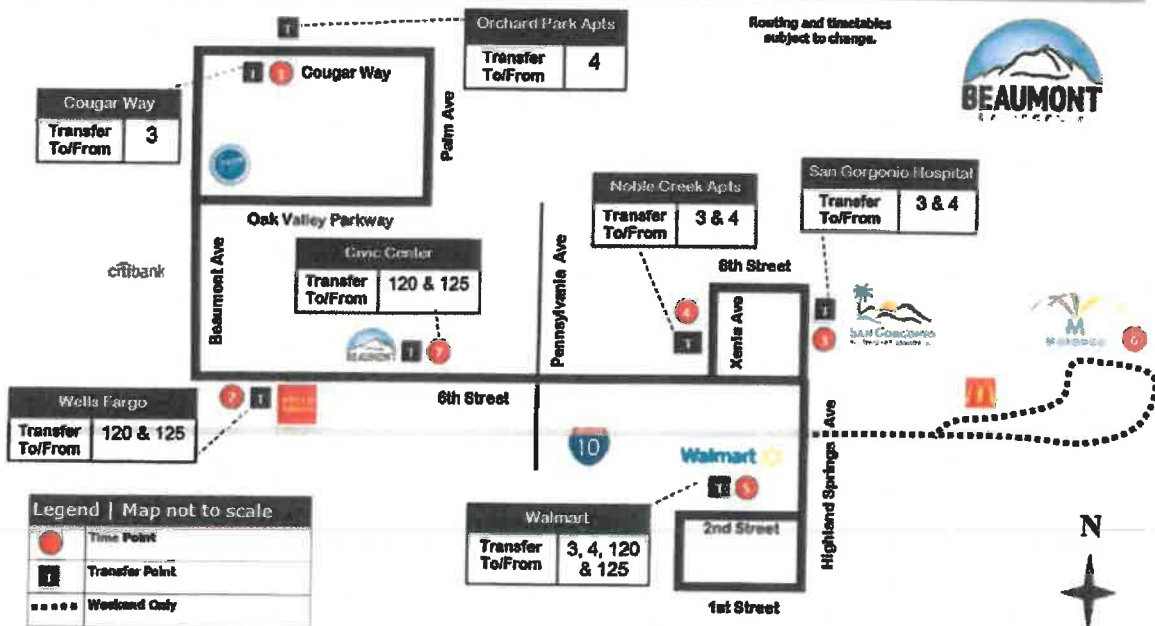

In FY 20, Commuter Link 120 will have a second bus added to the route. This will increase frequency of the popular route which in turn increases service to Calimesa to connect to San Bernardino and Beaumont. Additionally, the Commuter 120 will have a route change to service Casino Morongo and the Outlet mall on the days it runs with is Monday – Saturday.

COMMUTER LINK 120

Beaumont, Calimesa to San Bernardino Transit Center and Casino Morongo

Proposed Effective July 1, 2019

Legend | Map not to scale

	Time Point
	Transfer Point

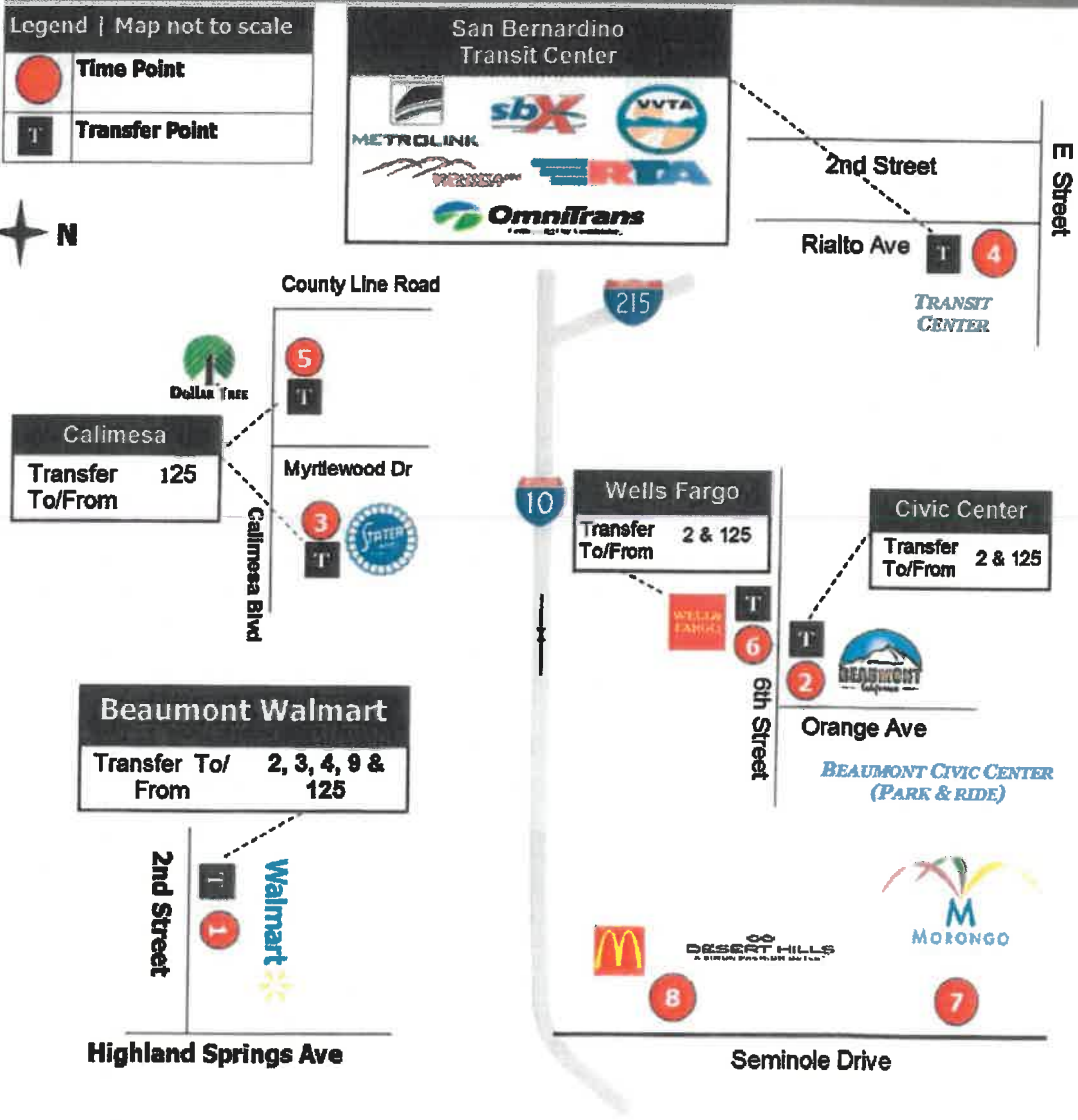

A Lyft voucher program for Senior and ADA passengers to offset the expense of DAR service is being explored. This voucher program will mirror a similar program offered by OmniTrans. The program consists of a 50-50 share in fare directly redeemable with Lyft when the service is used.

3.3 Marketing Plans and Promotions

FY 19 began a Free Fare Project through grant funding made available by LCTOP. Originally presented for free vouchers to college students and veterans, it has been extended to include all of Beaumont and Banning Local transit systems. Operating from March 1 through May 31, 2019, all passengers ride free on Beaumont and Banning Transit systems. Beaumont has seen an increase in passenger trips systemwide in March 2019 over March 2018 by 12.82% or 2,523 passenger trips.

In the month of July, \$0.25 (twenty-five cent) fare for youth passengers is offered on weekday Route 3, Route 4 and Saturday Route 3/4. Youth passengers, under the age of 18, can enjoy points of interest that these routes service. Destinations include the Community Center, library, Sports Park, city pool, shopping, as well as multiple parks.

In conjunction with October's Breast Cancer Awareness month, passengers wearing pink on Wednesdays are given a raffle ticket as they board the bus. A drawing of a winning raffle ticket was drawn each week for a November monthly pass. The winning ticket number and winner were posted on Pass Transit's Facebook.

Marketing and promotional appearances are attended throughout the year. Informational booths at back-to-school nights and orientations are attended by staff, annual Veteran's Expo, 'Stuff the Bus' food drive, Rider Appreciation events, and multiple community presentations and events.

Throughout the year our service is marketed with free rides, visible appearances, and provides functional use for the City. The opportunity to present the service and fleet to a captive audience has had positive effects with the community that would have normally not considered public transit. In 2018, three parades were participated in: Cherry Festival parade and two holiday light parades.

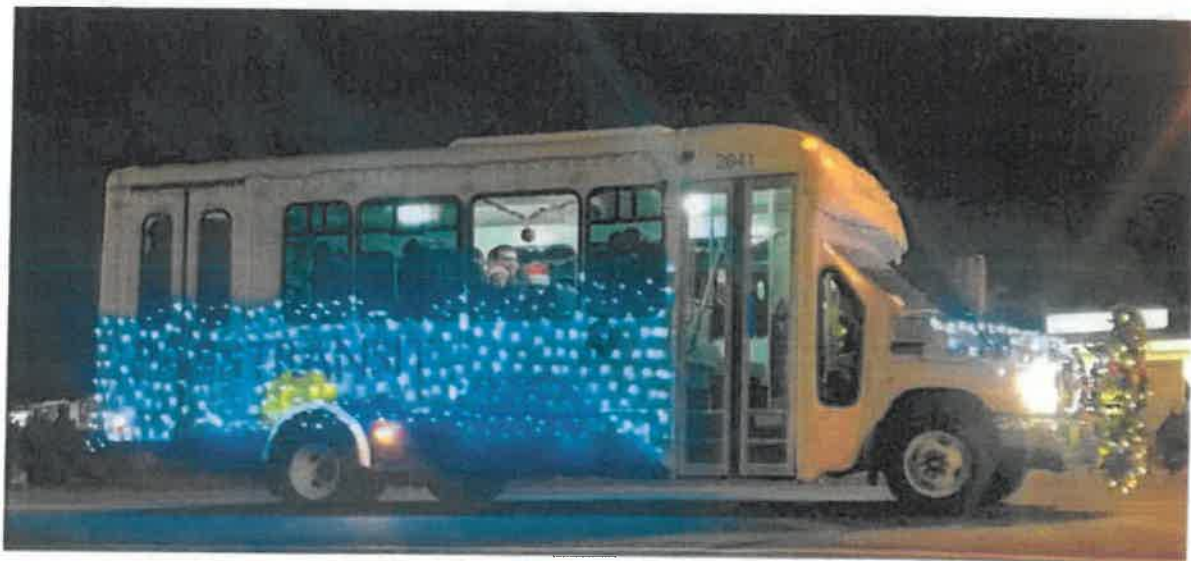

Beaumont offers free shuttle service to the annual Cherry Festival located in Beaumont. This annual festival, arts/crafts, food and entertainment gathering is a four-day event and has an attendance of over 50,000. In 2018, there were 1,619 passenger trips used by festival patrons.

Travel Training continues to be a successful program to teach Pass Area residents how to ride public transportation from the Pass Area to places of interest. Travel Training season begins in Spring and runs through summer with trips to Union Station, Downtown Disney and Oceanside. A common consensus with passengers is that public transportation is intimidating. Travel training offers guidance to individuals, ease concerns, and empower passengers to make similar trips on their own in the future. In the year 2018, 101 people took the trip with Beaumont.

3.4 Budget Impact on Proposed Changes

Route 2 restructuring will create opportunity to shift assets to expanding regional commuter service on the Commuter Link 120. Operating costs saved on Route 2 will be used on an additional bus on Commuter Link 120.

CHAPTER 4 – FINANCIAL AND CAPITAL PLANS

4.1 Operating and Capital Budget

Beaumont is requesting \$2,735,230 in LTF funding for FY20 for operating expenses. This is a \$331,390 increase over FY 19. Increases are attributed to the increase in fuel costs, salaries, and the need to conduct a COA.

Capital improvement project listed on Table 4 includes 6 projects.

- 20-01- CNG Station- \$1,500,000: Construction of CNG Station at new parcel currently in escrow located at 4th and Veile Ave.
- 20-02- Administrative, Fleet Maintenance & Operations Facility- \$500,000: construction of facility at parcel also designated as the site for CNG Station.
- 20-03- Brand and Logo Update- \$100,000: Replace bus stop signs, information kiosks and bus identification to correspond with new logo and branding.
- 20-04- Passenger Amenities- \$71,246 LCTOP grant: Funded through LCTOP, install bus shelters at 3 locations including the rehabilitation and improvement of Walmart Regional Connection Hub.
- 20-05- Shop Tools- \$40,000: Tools such as vehicle lift, heavy duty tire machine and tire balancer will increase safety for mechanics and save time while conducting their inspections and repairs.
- 20-06- Three Ford F550 Entourage Type E for Replacement- \$700,000: Aging fleet has met its useful life. Three vehicles have been identified as needing replacement.

4.2 Funding Plans to Support Proposed Operating and Capital Program

Capital projects are funded through STA as well as from LCTOP, MSRC and SGR grants.

4.3 Regulatory and Compliance Requirements

The American with Disabilities Act of 1990

The Dial-A-Ride service provides ADA paratransit service as a required element of ADA. The system uses a self-certification process with professional verification. Beaumont Transit works with RTA to certify ADA passengers and work under the umbrella of RTA's ADA policy.

Title VI

Beaumont Transit System does not utilize federal funds for operating expenses. As such, Title VI requirements do not currently apply to the transit system.

Alternatively Fueled Vehicles (RCTC Policy)

Beaumont Transit System operates ten CNG buses and nine gasoline powered. Future vehicle purchases, like all current purchases, will follow the RCTC and SCAQMD policies regarding alternative fuel for transit vehicles.

The State of California and California Air Resources Board has established a goal of transitioning all public fleet to electric buses by 2040. Beaumont is preparing for transition as our gas vehicles retire and intend to replace with electric buses in the coming FY's.

State Transit Assistance (STA) Compliance

Generally, Beaumont does not utilize STA funding for operating expenses. As such, compliance with the Public Utilities Commission requirement is not applicable.

Table 1 - Fleet Inventory
FY 2019/20 Short Range Transit Plan
 City of Beaumont

Bus (Motorbus) / Directly Operated

Year Built	Mfg. Code	Model Code	Seating Capacity	Lift and Ramp Equipped	Vehicle Length	Fuel Type Code	# of Active Vehicles FY 2018/19	# of Contingency Vehicles FY 2018/19	Life to Date Vehicle Miles Prior Year End FY 2017/18	Life to Date Vehicle Miles through March FY 2018/19	Average Lifetime Miles Per Active Vehicle As Of Year-To-Date (e.g., March) FY 2018/19
2010	CMD	C 5500	28	1	32	CN	1		190,064	209,957	209,957
2008	EBC	FORD E450	16	1	24	GA	1		262,608	264,564	264,564
2009	EBC	FORD E450	16	1	24	GA	1		253,737	255,602	255,602
2015	EBC	XHF 40	43	1	40	CN	1		42,308	49,224	49,224
2011	EDN	EDN	30	1	33	GA	1		208,250	235,534	235,534
2011	EDN	EDN	30	1	33	CN	1		120,509	139,876	139,876
2011	EDN	FORD 550	30	1	33	GA	1		232,890	273,299	273,299
2016	EDN	FORD E-450	20	1	24	CN	1		16,047	29,799	29,799
2011	EDN	FORD F550	30	1	33	GA	1		251,850	298,203	298,203
2016	EDN	FORD F550	30	1	33	CN	1		26,154	40,391	40,391
2015	EDN	XHF 40	43	1	40	CN	1		26,476	31,767	31,767
2015	EDN	XHF 40	43	1	40	CN	1		30,857	36,337	36,337
2009	GMC	C-5500	28	1	32	CN	1		160,603	176,510	176,510
2009	STR	C-5500	28	1	32	CN	1		176,728	195,886	195,886
2010	STR	C-5500	30	1	32	GA	1		263,811	301,699	301,699
Totals:							15		2,262,892	2,538,648	169,243

Table 1 - Fleet Inventory
FY 2019/20 Short Range Transit Plan
 City of Beaumont

Demand Response / Directly Operated

Year Built	Mfg. Code	Model Code	Seating Capacity	Lift and Ramp Equipped	Vehicle Length	Fuel Type Code	# of Active Vehicles FY 2018/19	# of Contingency Vehicles FY 2018/19	Life to Date Vehicle Miles Prior Year End FY 2017/18	Life to Date Vehicle Miles through March FY 2018/19	Average Lifetime Miles Per Active Vehicle As Of Year-To-Date (e-g, March) FY 2018/19
2010	FRD	Ford E450	16	1	24	GA	1		300,618	330,434	330,434
2010	FRD	Ford E-450	16	1	24	GA	1		304,491	337,947	337,947
2010	FRD	Ford E-450	16	1	24	GA	1		304,600	335,587	335,587
Totals:							3		909,709	1,003,968	334,656

Table 2 -- City of Beaumont -- SRTP Service Summary
FY 2019/20 Short Range Transit Plan
All Routes

	FY 2016/17 Audited	FY 2017/18 Audited	FY 2018/19 Plan	FY 2018/19 3rd Qtr Actual	FY 2019/20 Plan
Fleet Characteristics					
Peak-Hour Fleet		108	14	70	12
Financial Data					
Total Operating Expenses	\$2,385,210	\$2,567,639	\$2,670,933	\$1,673,098	\$2,610,230
Total Passenger Fare Revenue	\$233,847	\$235,430	\$268,724	\$169,009	\$281,000
Net Operating Expenses (Subsidies)	\$2,151,364	\$2,332,210	\$2,402,209	\$1,504,089	\$2,329,230
Operating Characteristics					
Unlinked Passenger Trips	194,129	197,775	242,743	144,237	165,316
Passenger Miles	927,769	945,103	1,161,519	689,859	1,436,725
Total Actual Vehicle Revenue Hours (a)	25,253.5	24,771.8	28,749.0	18,006.8	23,653.0
Total Actual Vehicle Revenue Miles (b)	424,978.0	420,009.0	528,135.0	332,915.9	481,289.0
Total Actual Vehicle Miles	453,177.0	447,136.0	556,675.0	350,391.7	504,023.0
Performance Characteristics					
Operating Cost per Revenue Hour	\$94.45	\$103.65	\$92.91	\$92.91	\$110.36
Farebox Recovery Ratio	9.80%	9.17%	10.06%	10.10%	10.76%
Subsidy per Passenger	\$11.08	\$11.79	\$9.90	\$10.43	\$14.09
Subsidy per Passenger Mile	\$2.32	\$2.47	\$2.07	\$2.18	\$1.62
Subsidy per Revenue Hour (a)	\$85.19	\$94.15	\$83.56	\$83.53	\$96.48
Subsidy per Revenue Mile (b)	\$5.06	\$5.55	\$4.55	\$4.52	\$4.84
Passenger per Revenue Hour (a)	7.7	8.0	8.4	8.0	7.0
Passenger per Revenue Mile (b)	0.46	0.47	0.46	0.43	0.34

(a) Train Hours for Rail Modes. (b) Car Miles for Rail Modes.

Table 2 -- City of Beaumont -- SRTP Service Summary
FY 2019/20 Short Range Transit Plan
Excluded Routes

	FY 2016/17 Audited	FY 2017/18 Audited	FY 2018/19 Plan	FY 2018/19 3rd Qtr Actual	FY 2019/20 Plan
Fleet Characteristics					
Peak-Hour Fleet		36	2	14	4
Financial Data					
Total Operating Expenses	\$1,967,672	\$984,718	\$560,000	\$292,205	\$1,364,146
Total Passenger Fare Revenue	\$179,273	\$44,807	\$19,930	\$8,872	\$123,109
Net Operating Expenses (Subsidies)	\$1,788,399	\$939,911	\$540,070	\$283,333	\$1,241,037
Operating Characteristics					
Unlinked Passenger Trips	145,012	18,923	8,605	5,028	63,111
Passenger Miles	696,058	90,830	41,305	24,134	848,500
Total Actual Vehicle Revenue Hours (a)	18,572.3	6,912.1	3,386.0	1,988.6	12,751.0
Total Actual Vehicle Revenue Miles (b)	337,034.0	165,555.0	94,301.0	52,582.0	343,950.0
Total Actual Vehicle Miles	355,849.0	173,479.0	98,238.0	53,558.0	352,253.0
Performance Characteristics					
Operating Cost per Revenue Hour	\$105.95	\$142.46	\$165.39	\$146.94	\$106.98
Farebox Recovery Ratio	9.11%	4.55%	3.55%	3.04%	9.02%
Subsidy per Passenger	\$12.33	\$49.67	\$62.76	\$56.35	\$19.66
Subsidy per Passenger Mile	\$2.57	\$10.35	\$13.08	\$11.74	\$1.46
Subsidy per Revenue Hour (a)	\$96.29	\$135.98	\$159.50	\$142.48	\$97.33
Subsidy per Revenue Mile (b)	\$5.31	\$5.68	\$5.73	\$5.39	\$3.61
Passenger per Revenue Hour (a)	7.8	2.7	2.5	2.5	4.9
Passenger per Revenue Mile (b)	0.43	0.11	0.09	0.10	0.18

(a) Train Hours for Rail Modes. (b) Car Miles for Rail Modes.

Table 2 -- City of Beaumont -- SRTP Service Summary
FY 2019/20 Short Range Transit Plan
Non-Excluded Routes

	FY 2016/17 Audited	FY 2017/18 Audited	FY 2018/19 Plan	FY 2018/19 3rd Qtr Actual	FY 2019/20 Plan
Fleet Characteristics					
Peak-Hour Fleet		72	12	56	8
Financial Data					
Total Operating Expenses	\$417,538	\$1,582,922	\$2,110,933	\$1,380,893	\$1,246,084
Total Passenger Fare Revenue	\$54,573	\$190,623	\$248,794	\$160,137	\$157,891
Net Operating Expenses (Subsidies)	\$362,965	\$1,392,298	\$1,862,139	\$1,220,756	\$1,088,193
Operating Characteristics					
Unlinked Passenger Trips	49,117	178,852	234,138	139,209	102,205
Passenger Miles	231,711	854,272	1,120,214	665,724	588,225
Total Actual Vehicle Revenue Hours (a)	6,681.2	17,859.8	25,363.0	16,018.2	10,902.0
Total Actual Vehicle Revenue Miles (b)	87,944.0	254,454.0	433,834.0	280,333.9	137,339.0
Total Actual Vehicle Miles	97,328.0	273,657.0	458,437.0	296,833.7	151,770.0
Performance Characteristics					
Operating Cost per Revenue Hour	\$62.49	\$88.63	\$83.23	\$86.21	\$114.30
Farebox Recovery Ratio	13.07%	12.04%	11.78%	11.60%	12.67%
Subsidy per Passenger	\$7.39	\$7.78	\$7.95	\$8.77	\$10.65
Subsidy per Passenger Mile	\$1.57	\$1.63	\$1.66	\$1.83	\$1.85
Subsidy per Revenue Hour (a)	\$54.33	\$77.96	\$73.42	\$76.21	\$99.82
Subsidy per Revenue Mile (b)	\$4.13	\$5.47	\$4.29	\$4.35	\$7.92
Passenger per Revenue Hour (a)	7.4	10.0	9.2	8.7	9.4
Passenger per Revenue Mile (b)	0.56	0.70	0.54	0.50	0.74

(e) Train Hours for Rail Modes. (b) Car Miles for Rail Modes.

Table 2 -- Beaumont-BUS -- SRTP Service Summary
FY 2019/20 Short Range Transit Plan
All Routes

	FY 2016/17 Audited	FY 2017/18 Audited	FY 2018/19 Plan	FY 2018/19 3rd Qtr Actual	FY 2019/20 Plan
Fleet Characteristics					
Peak-Hour Fleet		96	12	62	11
Financial Data					
Total Operating Expenses	\$2,245,883	\$2,259,302	\$2,416,000	\$1,624,677	\$2,380,230
Total Passenger Fare Revenue	\$212,713	\$215,369	\$258,988	\$165,912	\$258,000
Net Operating Expenses (Subsidies)	\$2,033,169	\$2,043,934	\$2,157,012	\$1,458,765	\$2,122,230
Operating Characteristics					
Unlinked Passenger Trips	184,250	187,489	233,860	138,191	156,187
Passenger Miles	884,400	899,947	1,122,524	663,317	1,388,341
Total Actual Vehicle Revenue Hours (a)	22,106.6	21,606.1	26,258.0	16,183.8	20,866.0
Total Actual Vehicle Revenue Miles (b)	384,576.0	380,714.0	497,194.0	310,434.0	446,602.0
Total Actual Vehicle Miles	407,720.0	404,305.0	522,772.0	325,506.2	465,746.0
Performance Characteristics					
Operating Cost per Revenue Hour	\$101.59	\$104.57	\$92.01	\$100.39	\$114.07
Farebox Recovery Ratio	9.47%	9.53%	10.71%	10.21%	10.83%
Subsidy per Passenger	\$11.03	\$10.90	\$9.22	\$10.56	\$13.59
Subsidy per Passenger Mile	\$2.30	\$2.27	\$1.92	\$2.20	\$1.53
Subsidy per Revenue Hour (a)	\$91.97	\$94.60	\$82.15	\$90.14	\$101.71
Subsidy per Revenue Mile (b)	\$5.29	\$5.37	\$4.34	\$4.70	\$4.75
Passenger per Revenue Hour (a)	8.3	8.7	8.9	8.5	7.5
Passenger per Revenue Mile (b)	0.48	0.49	0.47	0.45	0.35

(a) Train Hours for Rail Modes. (b) Car Miles for Rail Modes.

Table 2 -- Beaumont-BUS -- SRTP Service Summary
FY 2019/20 Short Range Transit Plan
Excluded Routes

	FY 2016/17 Audited	FY 2017/18 Audited	FY 2018/19 Plan	FY 2018/19 3rd Qtr Actual	FY 2019/20 Plan
Fleet Characteristics					
Peak-Hour Fleet		36	2	14	4
Financial Data					
Total Operating Expenses	\$1,967,672	\$984,718	\$560,000	\$292,205	\$1,364,146
Total Passenger Fare Revenue	\$179,273	\$44,807	\$19,930	\$8,872	\$123,109
Net Operating Expenses (Subsidies)	\$1,788,399	\$939,911	\$540,070	\$283,333	\$1,241,037
Operating Characteristics					
Unlinked Passenger Trips	145,012	18,923	8,605	5,028	63,111
Passenger Miles	696,058	90,830	41,305	24,134	848,500
Total Actual Vehicle Revenue Hours (a)	18,572.3	6,912.1	3,386.0	1,988.6	12,751.0
Total Actual Vehicle Revenue Miles (b)	337,034.0	165,555.0	94,301.0	52,582.0	343,950.0
Total Actual Vehicle Miles	355,849.0	173,479.0	98,238.0	53,558.0	352,253.0
Performance Characteristics					
Operating Cost per Revenue Hour	\$105.95	\$142.46	\$165.39	\$146.94	\$106.98
Farebox Recovery Ratio	9.11%	4.55%	3.55%	3.04%	9.02%
Subsidy per Passenger	\$12.33	\$49.67	\$62.76	\$56.35	\$19.66
Subsidy per Passenger Mile	\$2.57	\$10.35	\$13.08	\$11.74	\$1.46
Subsidy per Revenue Hour (a)	\$96.29	\$135.98	\$159.50	\$142.48	\$97.33
Subsidy per Revenue Mile (b)	\$5.31	\$5.68	\$5.73	\$5.39	\$3.61
Passenger per Revenue Hour (a)	7.8	2.7	2.5	2.5	4.9
Passenger per Revenue Mile (b)	0.43	0.11	0.09	0.10	0.18

(a) Train Hours for Rail Modes. (b) Car Miles for Rail Modes.

Table 2 -- Beaumont-BUS -- SRTP Service Summary
FY 2019/20 Short Range Transit Plan
Non-Excluded Routes

	FY 2016/17 Audited	FY 2017/18 Audited	FY 2018/19 Plan	FY 2018/19 3rd Qtr Actual	FY 2019/20 Plan
Fleet Characteristics					
Peak-Hour Fleet		60	10	48	7
Financial Data					
Total Operating Expenses	\$278,211	\$1,274,585	\$1,856,000	\$1,332,472	\$1,016,084
Total Passenger Fare Revenue	\$33,440	\$170,562	\$239,058	\$157,040	\$134,891
Net Operating Expenses (Subsidies)	\$244,771	\$1,104,022	\$1,616,942	\$1,175,432	\$881,193
Operating Characteristics					
Unlinked Passenger Trips	39,238	168,566	225,255	133,163	93,076
Passenger Miles	188,342	809,117	1,081,219	639,182	539,841
Total Actual Vehicle Revenue Hours (a)	3,534.2	14,694.0	22,872.0	14,195.2	8,115.0
Total Actual Vehicle Revenue Miles (b)	47,544.0	215,159.0	402,893.0	257,852.0	102,652.0
Total Actual Vehicle Miles	51,871.0	230,826.0	424,534.0	271,948.2	113,493.0
Performance Characteristics					
Operating Cost per Revenue Hour	\$78.72	\$86.74	\$81.15	\$93.87	\$125.21
Farebox Recovery Ratio	12.02%	13.38%	12.88%	11.79%	13.27%
Subsidy per Passenger	\$6.24	\$6.55	\$7.18	\$8.83	\$9.47
Subsidy per Passenger Mile	\$1.30	\$1.36	\$1.50	\$1.84	\$1.63
Subsidy per Revenue Hour (a)	\$69.26	\$75.13	\$70.70	\$82.80	\$108.59
Subsidy per Revenue Mile (b)	\$5.15	\$5.13	\$4.01	\$4.56	\$8.58
Passenger per Revenue Hour (a)	11.1	11.5	9.8	9.4	11.5
Passenger per Revenue Mile (b)	0.83	0.78	0.56	0.52	0.91

(a) Train Hours for Rail Modes. (b) Car Miles for Rail Modes.

**City of Beaumont
FY 2019/2020 - FY 2021/2022**

Table 2A- Excluded Routes

Route	Mode	Service Type	Route Description	Date of Implementation	Exemption End Date
120	FR	Directly Operated	Monday - Saturday Commuter Link Service	September 2018	September 2021
125	FR	Directly Operated	Direct service from Beaumont Walmart to Calimesa, Mountain Grove Plaza, Kaiser Permanente Redlands Medical Offices and VA Ambulatory Care Center.	September 2018	September 2021
2	FR	Directly Operated	Monday- Sunday Service. Trunk route servicing Cherry Valley to Walmart.	July 2019	July 2022

Note: Excluded routes are new routes or new service extensions that are eligible for exemption from the farebox recovery requirements.



Table 3 - SRTP Route Statistics
City of Beaumont -- 2
FY 2019/20
All Routes

Data Elements											
Route #	Day Type	Peak Vehicles	Passengers	Passenger Miles	Revenue Hours	Total Hours	Revenue Miles	Total Miles	Operating Cost	Passenger Revenue	Net Subsidy
BEA-120	All Days	2	18,558	501,066	5,947.0	6,352.0	192,207.0	196,485.0	\$825,238	\$53,804	\$571,434
BEA-125	All Days	1	5,857	122,997	3,187.0	3,338.0	94,097.0	95,525.0	\$350,262	\$19,196	\$331,066
BEA-2	All Days	1	38,696	224,437	3,617.0	3,563.0	57,646.0	60,243.0	\$388,646	\$50,109	\$338,537
BEA-3	Weekday	1	23,475	136,155	2,624.0	2,767.0	35,659.0	39,576.0	\$300,611	\$32,380	\$268,231
BEA-3/4	Saturday	1	2,885	16,733	580.0	611.0	8,781.0	9,156.0	\$130,102	\$8,650	\$121,452
BEA-4	Weekday	1	24,200	140,360	2,935.0	3,018.0	39,798.0	40,649.0	\$300,978	\$31,692	\$269,286
BEA-7	Weekday	3	30,692	178,014	1,070.0	1,244.0	13,886.0	17,479.0	\$145,291	\$41,632	\$103,659
BEA-9	Weekday	1	11,824	68,579	906.0	550.0	4,728.0	6,633.0	\$139,102	\$20,537	\$118,565
BEA-DAR	All Days	1	9,129	48,384	2,787.0	3,080.0	34,687.0	36,277.0	\$230,000	\$23,000	\$207,000
Service Provider Totals		12	165,316	1,436,725	23,653.0	24,523.0	481,289.0	504,023.0	\$2,610,230	\$281,000	\$2,329,230



Table 3 - SRTP Route Statistics
 City of Beaumont -- 2
 FY 2019/20
 All Routes

Route #	Day Type	Performance Indicators									
		Operating Cost Per Revenue Hour	Operating Cost Per Revenue Mile	Cost Per Passenger	Farebox Recovery Ratio	Subsidy Per Passenger	Subsidy Per Passenger Mile	Subsidy Per Revenue Hour	Subsidy Per Revenue Mile	Passengers Per Hour	Passengers Per Mile
BEA-120	All Days	\$105.14	\$3.25	\$33.69	8.60%	\$30.79	\$1.14	\$96.09	\$2.97	3.1	0.10
BEA-125	All Days	\$109.90	\$3.72	\$59.80	5.48%	\$56.52	\$2.69	\$103.88	\$3.52	1.8	0.06
BEA-2	All Days	\$107.45	\$6.74	\$10.04	12.89%	\$0.75	\$1.51	\$93.60	\$5.87	10.7	0.67
BEA-3	Weekday	\$114.56	\$8.43	\$12.81	10.77%	\$11.43	\$1.97	\$102.22	\$7.52	8.9	0.66
BEA-3/4	Saturday	\$224.31	\$14.82	\$45.10	6.64%	\$42.10	\$7.26	\$209.40	\$13.83	5.0	0.33
BEA-4	Weekday	\$102.55	\$7.56	\$12.44	10.52%	\$11.13	\$1.92	\$91.75	\$6.77	8.2	0.61
BEA-7	Weekday	\$135.79	\$10.62	\$4.73	28.65%	\$3.38	\$0.58	\$96.88	\$7.57	28.7	2.24
BEA-9	Weekday	\$153.53	\$29.42	\$11.76	14.76%	\$10.03	\$1.73	\$130.87	\$25.08	13.1	2.50
BEA-DAR	All Days	\$82.53	\$6.63	\$25.19	10.00%	\$22.67	\$4.28	\$74.27	\$5.97	3.3	0.26
Service Provider Totals		\$110.36	\$5.42	\$15.79	10.76%	\$14.09	\$1.62	\$98.48	\$4.84	7.0	0.34

**City of Beaumont
Pass Transit
FY 2018/2019**

Table 3A- Individual Route Descriptions and Area Served

Route	Description	Area/Sites Served
2	Trunk Route on major arterial roads of Beaumont Ave, 6th Street as well as Ramsey St into Cabazon	Areas of interest include Beaumont downtown commercial area and 2nd Street Marketplace, including banks and grocery stores. Also services Walmart transportation hub, San Gorgonio Hospital.
3	Cherry Valley via Sundance to Walmart	Services schools such as elementary, middle and high school, deviations into rural Cherry Valley, 2nd Street Marketplace and connection opportunity with Walmart transportation hub
4	Downtown Beaumont via residential	Services community center, elementary, middle schools, high school, library, sports park, 2nd Street Marketplace and Walmart transportation hub
7	Northwest Beaumont	Middle schools and high school, Fairway Canyon and Tournament Hills.
9	South Beaumont	Middle schools and high school, Seneca Springs
3/4	Combination of Routes 3 and 4	Saturday only service servicing Cherry Valley, Sports Park, community center, and commercial areas of Beaumont.
120	Commuter Service to San Bernardino	Direct service from Beaumont Walmart to Calimesa and San Bernardino Transit Center.
125	Commuter Service to VA Ambulatory Care Center	Direct service from Beaumont Walmart to Calimesa, Mountain Grove Plaza, Kaiser Permanente Redlands Medical Offices and VA Ambulatory Care Center.
DAR	Curb to Curb Direct Service for qualified residents of Beaumont and parts of Cherry Valley	Citywide service for those qualified passengers living 3/4 of a mile of fixed route service in Beaumont and Cherry Valley to Beaumont, Cherry Valley and parts of Banning.

City of Beaumont
FY 2019/2020
Summary of Funds Requested
Short Range Transit Plan

Table 4 - Summary of Funds Requested for FY-2019/2020

Project Description	Total Amount of Funds	LTF	STA	LCTOP	Fare Box	Interest
Operating Expenses FR & Admin	\$ 1,589,730	\$ 1,404,730			\$ 185,000	
Commuter 120 & 125 Operating & Admin	\$ 1,048,500	\$ 975,500			\$ 73,000	
FY 16/17 LCTOP Commuter 125 Operations	\$ 16,899			\$ 16,899		
DAR Operating Expenses	\$ 253,000	\$ 230,000			\$ 23,000	
Interest & Other Income	\$ 6,200					\$ 6,200
Comprehensive Operations Analysis	\$ 125,000	\$ 125,000				
Subtotal: Operating	\$ 3,039,329	\$ 2,735,230	\$ -	\$ 16,899	\$ 281,000	\$ 6,200
Capital	Total Amount of Funds	LTF	STA	LCTOP	Fare Box	Interest
Project Number (1)						
CNG Station	\$ 1,500,000		\$ 1,500,000			
Administrative, Fleet Maintenance & Operations Facility	\$ 500,000		\$ 500,000			
Brand and Logo Update	\$ 100,000		\$ 100,000			
Passenger Amenities	\$ 71,246			\$ 71,246		
Shop Tools	\$ 40,000		\$ 40,000			
3 - Ford F550 Entourage Type E for Replacement	\$ 700,000		\$ 700,000			
Subtotal: Capital	\$ 2,911,246	\$ -	\$ 2,840,000	\$ 71,246	\$ -	\$ -
Total: Operating & Capital	\$ 5,950,575	\$ 2,735,230	\$ 2,840,000	\$ 88,145	\$ 281,000	\$ 6,200

Table 4A- Capital Project Justification

PROJECT NUMBER (If existing project in FTIP, indicate FTIP ID Number):

S RTP Project No: 2020-01 FTIP No: _____

PROJECT NAME:

CNG Station

PROJECT DESCRIPTION:

CNG Station to be built at a location closing sale at 4th and Veile Ave in Beaumont. This will also be a location where transit administration, fleet maintenance and operations will be located. The requested funding will be used to build the station infrastructure.

PROJECT JUSTIFICATION:

There are no other CNG fuel stations available to the public in the Pass Area. To be in the industrial area of Beaumont, the station will be accessible to Interstate 10, Highway 60 and 79, and conducive to fueling commercial vehicles. Currently, Beaumont operates 10 CNG buses and does not have a reliable place to fuel them. Daily, a single mechanic is charged with fueling buses by driving outside of the Pass Area to fuel (Hemet, Moreno Valley and Redlands). This request will be used for the building of the station. Prior year allocations will be used, in part, for the purchase of property on 4th and Veile Ave.

PROJECT SCHEDULE:

Start Date	Completion Date
Current	June 2021

PROJECT FUNDING SOURCES (REQUESTED):

Fund Type	Fiscal Year	Amount
STA	19-20	\$1,500,000
Total		\$1,500,000

PRIOR YEAR PROJECTS OF A SIMILAR NATURE WITH UNEXPENDED BALANCE INCLUDING PROJECTS APPROVED BUT NOT YET ORDERED (INCLUDE FTA GRANT#, FTIP ID# AND RCTC'S SRTP CAPITAL GRANT #)

FTA Grant #	FTIP ID #	RCTC/S RTP Project #	Description	Unexpended Balance (as of 5/1/19)
N/A	N/A	15-3	CNG Station Improvements	199,095.90
		16-1	CNG Station Improvements	300,000
		18-1	CNG Station Improvements	300,000
		19-1	CNG Station Improvements	300,000

Table 4A- Capital Project Justification

PROJECT NUMBER (If existing project in FTIP, indicate FTIP ID Number):

SRTP Project No: 2020-02 FTIP No: _____

PROJECT NAME:

Administrative, Fleet Maintenance & Operations Facility

PROJECT DESCRIPTION:

Construction of administration, fleet maintenance and operations Facility located in the industrial area of Beaumont.

PROJECT JUSTIFICATION:

Currently, administrative, operations and fleet maintenance are in two different locations and have outgrown their facilities. Buses are parked in both locations because all buses do not fit entirely at either location. The separation of the department is creating increased operational expenses. Administration and operations are located at City Hall campus while maintenance is located on California Ave & 5th Street. Both locations are in a downtown specific area and have updated uses in the general plan. It is necessary to consolidate transit in one location, outside of the downtown area, and into an area conducive to the business of transit. Building will be located in the same location as CNG Station at 4th & Veile Ave.

PROJECT SCHEDULE:

Start Date	Completion Date
December 2019	June 2023

PROJECT FUNDING SOURCES (REQUESTED):

Fund Type	Fiscal Year	Amount
STA	19-20	\$5,00,000
Total		\$5,00,000

PRIOR YEAR PROJECTS OF A SIMILAR NATURE WITH UNEXPENDED BALANCE INCLUDING PROJECTS APPROVED BUT NOT YET ORDERED (INCLUDE FTA GRANT#, FTIP ID# AND RCTC'S SRTP CAPITAL GRANT #)

FTA Grant #	FTIP ID #	RCTC/SRTP Project #	Description	Unexpended Balance (as of 5/1/19)
				0

Table 4A- Capital Project Justification

PROJECT NUMBER (If existing project in FTIP, indicate FTIP ID Number):

S RTP Project No: 2020-03 FTIP No: _____

PROJECT NAME:

Brand and Logo Update

PROJECT DESCRIPTION:

Wrap buses and produce bus stop signage with new design.

PROJECT JUSTIFICATION:

Bus wraps and bus stop signage are faded, deteriorated and vandalized. A new logo, including color scheme and graphics will be placed on buses and bus stop signs produced to distinguish Beaumont Transit system from other transit systems in the area.

PROJECT SCHEDULE:

Start Date	Completion Date
December 2019	June 2020

PROJECT FUNDING SOURCES (REQUESTED):

Fund Type	Fiscal Year	Amount
STA	19-20	\$100,000
Total		\$100,000

PRIOR YEAR PROJECTS OF A SIMILAR NATURE WITH UNEXPENDED BALANCE INCLUDING PROJECTS APPROVED BUT NOT YET ORDERED (INCLUDE FTA GRANT#, FTIP ID# AND RCTC'S SRTP CAPITAL GRANT #)

FTA Grant #	FTIP ID #	RCTC/SRTP Project #	Description	Unexpended Balance (as of 5/1/19)
				0

Table 4A- Capital Project Justification

PROJECT NUMBER (If existing project in FTIP, indicate FTIP ID Number):

S RTP Project No: 2020-04 FTIP No: _____

PROJECT NAME:

Passenger Amenities

PROJECT DESCRIPTION:

Install passenger amenities including bus shelters, benches, lighting, trashcans and landscaping at 3 locations.

PROJECT JUSTIFICATION:

Funded by LCTOP grant, passenger amenities will be installed in two locations of disadvantaged community as well as improving Walmart regional connection area.

PROJECT SCHEDULE:

Start Date	Completion Date
September 2019	June 2020

PROJECT FUNDING SOURCES (REQUESTED):

Fund Type	Fiscal Year	Amount
LCTOP	18-19	\$71,246
Total		\$71,246

PRIOR YEAR PROJECTS OF A SIMILAR NATURE WITH UNEXPENDED BALANCE INCLUDING PROJECTS APPROVED BUT NOT YET ORDERED (INCLUDE FTA GRANT#, FTIP ID# AND RCTC'S SRTP CAPITAL GRANT #)

FTA Grant #	FTIP ID #	RCTC/S RTP Project #	Description	Unexpended Balance (as of 5/1/19)
				0

Table 4A- Capital Project Justification

PROJECT NUMBER (If existing project in FTIP, indicate FTIP ID Number):

SRTP Project No: 2020-05 FTIP No: _____

PROJECT NAME:

Shop Tools

PROJECT DESCRIPTION:

Purchase of vehicle lift, heavy duty tire machine and tire balancer.

PROJECT JUSTIFICATION:

Vehicle maintenance department is responsible for the repair and maintenance of all transit fleet. To complete work, mechanics need basic tools to increase safety and avoid injury. Heavy duty tire machine will remove the physical activity of removing large tires and relocating to a different area of the shop. Additionally, shuttle vehicles are being repaired on floor stands, a vehicle lift is necessary for proper maintenance of the vehicles.

PROJECT SCHEDULE:

Start Date	Completion Date
July 2019	November 2019

PROJECT FUNDING SOURCES (REQUESTED):

Fund Type	Fiscal Year	Amount
STA	19-20	\$40,000
Total		\$40,000

PRIOR YEAR PROJECTS OF A SIMILAR NATURE WITH UNEXPENDED BALANCE INCLUDING PROJECTS APPROVED BUT NOT YET ORDERED (INCLUDE FTA GRANT#, FTIP ID# AND RCTC'S SRTP CAPITAL GRANT #)

FTA Grant #	FTIP ID #	RCTC/SRTP Project #	Description	Unexpended Balance (as of 5/1/19)
		17-2	Mobile Bus Lift, Jack Stands & Tools	\$ 4,742.59

Table 4A- Capital Project Justification

PROJECT NUMBER (If existing project in FTIP, indicate FTIP ID Number):

S RTP Project No: 2020-06 FTIP No: _____

PROJECT NAME:

3- CNG Ford F 550 Entourage Type E for Replacement

PROJECT DESCRIPTION:

Purchase of three new CNG fueled cutaway buses for replacement with video camera and GPS system.

PROJECT JUSTIFICATION:

Five of Beaumont’s nineteen bus fleet has mileage of over 10-year life expectancy. These new vehicles will replace retiring vehicles.

PROJECT SCHEDULE:

Start Date	Completion Date
July 2019	June 2020

PROJECT FUNDING SOURCES (REQUESTED):

Fund Type	Fiscal Year	Amount
STA	19-20	\$700,000
Total		\$700,000

PRIOR YEAR PROJECTS OF A SIMILAR NATURE WITH UNEXPENDED BALANCE INCLUDING PROJECTS APPROVED BUT NOT YET ORDERED (INCLUDE FTA GRANT#, FTIP ID# AND RCTC’S SRTP CAPITAL GRANT #)

FTA Grant #	FTIP ID #	RCTC/S RTP Project #	Description	Unexpended Balance (as of 5/1/19)
		12-01	GPS System	\$ 4,117.75
N/A	N/A	15-1	2 Type 7 Bus for Replacement/Expansion	\$29,725.82
		19-02	Type H EZ Rider II	\$18,417.50

City of Beaumont
FY 2020/2021
Summary of Funds Requested
Short Range Transit Plan

Table 5.1 - Summary of Funds Requested for FY-2020/2021

Project Description	Total Amount of Funds	LTF	STA	LCTOP	Fare Box	Interest
Operating Expenses FR and Admin	\$ 1,884,730	\$ 1,695,730			\$ 189,000	
Commuter 120 & 125 Operating Expenses	\$ 827,685	\$ 748,685			\$ 79,000	
DAR Operating Expenses	\$ 253,000	\$ 230,000			\$ 23,000	
Interest & Other Income	\$ 6,200					\$ 6,200
Subtotal: Operating	\$ 2,971,615	\$ 2,674,415	\$ -	\$ -	\$ 291,000	\$ 6,200
Project Description	Total Amount of Funds	LTF	STA	LCTOP	Fare Box	Interest
CNG Station	200,000		200,000			
Administrative, Maintenance and Operations Facility	5,000,000		5,000,000			
Subtotal: Capital	\$ 5,200,000	\$ -	\$ 5,200,000	\$ -	\$ -	\$ -
Total: Operating & Capital	\$ 8,171,615	\$ 2,674,415	\$ 5,200,000	\$ -	\$ 291,000	\$ 6,200

Table 5.1- Capital Project Justification

PROJECT NUMBER (If existing project in FTIP, indicate FTIP ID Number):

SRTP Project No: 2021-01 FTIP No: _____

PROJECT NAME:

CNG Station

PROJECT DESCRIPTION:

Construction of CNG Station at 4th Street & Veile Ave.

PROJECT JUSTIFICATION:

CNG Station in the same location as administration, fleet maintenance and operations, this fueling station will be open to the public. There are no other CNG fueling stations in the Pass Area open to the public. Located in the industrial area with access to Interstate 10, Highway 60 and 79, this fueling site location will be conducive to fueling commercial vehicles. Beaumont transit does not have a reliable CNG fueling location in the Pass Area. The construction of a station will eliminate the need for additional staff time and vehicle miles to travel out of the Pass Area to fuel.

PROJECT SCHEDULE:

Start Date	Completion Date
Current	June 2021

PROJECT FUNDING SOURCES (REQUESTED):

Fund Type	Fiscal Year	Amount
STA	20-21	200,000
Total		\$200,000

PRIOR YEAR PROJECTS OF A SIMILAR NATURE WITH UNEXPENDED BALANCE INCLUDING PROJECTS APPROVED BUT NOT YET ORDERED (INCLUDE FTA GRANT#, FTIP ID# AND RCTC'S SRTP CAPITAL GRANT #)

FTA Grant #	FTIP ID #	RCTC/SRTP Project #	Description	Unexpended Balance (as of 4/1/19)
			MSRC	200,000

Table 5.1- Capital Project Justification

PROJECT NUMBER (If existing project in FTIP, indicate FTIP ID Number):

S RTP Project No: 2021-02 FTIP No: _____

PROJECT NAME:

Administrative, Maintenance and Operations Facility

PROJECT DESCRIPTION:

Construction of administration, fleet maintenance and operations Facility located in the industrial area of 4th St and Veile Ave.

PROJECT JUSTIFICATION:

Currently, administrative, operations and fleet maintenance are in two different locations and have outgrown their facilities. Buses are parked in both locations because all buses do not fit entirely at either location. Administration and operations are located at City Hall campus while maintenance is located on California Ave & 5th Street. Both locations are in a downtown specific area and have updated uses in the general plan. It is necessary to consolidate transit in one location, outside of the downtown area, and into an area conducive to the business of transit. Building will be located in the same location as CNG Station.

PROJECT SCHEDULE:

Start Date	Completion Date
December 2019	June 2023

PROJECT FUNDING SOURCES (REQUESTED):

Fund Type	Fiscal Year	Amount
STA	20-21	\$5,000,000
Total		\$5,000,000

PRIOR YEAR PROJECTS OF A SIMILAR NATURE WITH UNEXPENDED BALANCE INCLUDING PROJECTS APPROVED BUT NOT YET ORDERED (INCLUDE FTA GRANT#, FTIP ID# AND RCTC'S SRTP CAPITAL GRANT #)

FTA Grant #	FTIP ID #	RCTC/SRTP Project #	Description	Unexpended Balance (as of 4/1/19)

City of Beaumont
FY 2021/2022
Summary of Funds Requested
Short Range Transit Plan

Table 5.2 - Summary of Funds Requested for FY-2021/2022

Project Description	Total Amount of Funds	LTF	STA	LCTOP	Fare Box	Interest
Operating Expenses FR and Admin	\$ 1,884,730	\$ 1,695,730			\$ 189,000	
Commuter 120 & 125 Operating Expenses	\$ 829,185	\$ 748,685			\$ 80,500	
DAR Operating Expenses	\$ 253,000	\$ 230,000			\$ 23,000	
Interest & Other Income	\$ 4,500					\$ 4,500
Subtotal: Operating	\$ 2,971,415	\$ 2,674,415	\$ -	\$ -	\$ 292,500	\$ 4,500
Project Description	Total Amount of Funds	LTF	STA	LCTOP	Fare Box	Interest
Capital Project Number (1)						
Electric Vehicles, Buses & Infrastructure	5,000,000		5,000,000			
Subtotal: Capital	\$ 5,000,000		\$ 5,000,000			
Total: Operating & Capital	\$ 7,971,415	\$ 2,674,415	\$ 5,000,000	\$ -	\$ 292,500	\$ 4,500

Table 5.2- Capital Project Justification

PROJECT NUMBER (If existing project in FTIP, indicate FTIP ID Number):

SRTP Project No: 2022-01 FTIP No: _____

PROJECT NAME:

Electric Vehicles, Buses and Infrastructure

PROJECT DESCRIPTION:

Construct electric vehicle charging station at operations facility, located at 4th St & Viele Ave. Procure electric shuttle vehicles and buses for the replacement of gas vehicles currently in the fleet.

PROJECT JUSTIFICATION:

Existing gas vehicles are aging and reaching life expectancy. In coordination with the mandates of the State of California and their emissions goal, Beaumont Transit intends to retiring gas vehicles and buses with electric vehicles and buses.

PROJECT SCHEDULE:

Start Date	Completion Date
September 2021	June 2023

PROJECT FUNDING SOURCES (REQUESTED):

Fund Type	Fiscal Year	Amount
STA	22-01	\$5,000,000
Total		\$5,000,000

PRIOR YEAR PROJECTS OF A SIMILAR NATURE WITH UNEXPENDED BALANCE INCLUDING PROJECTS APPROVED BUT NOT YET ORDERED (INCLUDE FTA GRANT#, FTIP ID# AND RCTC'S SRTP CAPITAL GRANT #)

FTA Grant #	FTIP ID #	RCTC/SRTP Project #	Description	Unexpended Balance (as of 4/1/19)

City of Beaumont
Pass Transit
FY 2019/2020 - FY 2021/2022

Table 6- Progress to Implement Triennial Performance Audit

Audit Recommendations (Covering FY 2012/13-2014/15)	Action(s) Taken and Results
Continue to ensure the timely completion and submittal of the annual State Controller Transit Operators Financial Transactions Reports.	Beaumont continues to strive for timely completion of SCO reports. New software has been purchased and migration into it complete. Additional staff in the Finance Department has been added to prevent delays.
Prepare and submit separate State Controller Transit Operators Financial Transactions Reports for general public transit and specialized service.	Separate documents have been prepared and submitted.
Work with Riverside Transit Agency and Mt San Jacinto College on fare revenue reimbursement from the college GoPass Revenue Agreement.	Mt San Jacinto and RTA were approached. With no solution available to share fare revenue, Beaumont Pass Transit has applied for a grant to transport college students aside from the Go Pass program
Track ridership trends for those using mobility devices.	Passengers using mobility devices are being tracked.

Table 7 -- Service Provider Performance Targets Report
 FY 2018/19 Short Range Transit Plan Review
 City of Beaumont

Data Elements	FY 2018/19 Plan	FY 2018/19 Target	FY 2018/19 Year to Date Through 3rd Quarter	Year to Date Performance Scorecard
Unlinked Passenger Trips	242,743			
Passenger Miles	1,161,519			
Total Actual Vehicle Revenue Hours	28,749.0			
Total Actual Vehicle Revenue Miles	528,135.0			
Total Actual Vehicle Miles	556,675.0			
Total Operating Expenses	\$2,670,933			
Total Passenger Fare Revenue	\$268,724			
Net Operating Expenses	\$2,402,209			
Performance Indicators				
Mandatory:				
1. Farebox Recovery Ratio	10.06%	>= 10.00%	10.10%	Meets Target
Discretionary:				
1. Operating Cost Per Revenue Hour	\$92.91	<= \$91.10	\$92.91	Fails to Meet Target
2. Subsidy Per Passenger	\$9.90	>= \$9.10 and <= \$12.32	\$10.43	Meets Target
3. Subsidy Per Passenger Mile	\$2.07	>= \$1.90 and <= \$2.58	\$2.18	Meets Target
4. Subsidy Per Hour	\$83.56	>= \$72.33 and <= \$97.85	\$83.53	Meets Target
5. Subsidy Per Mile	\$4.55	>= \$4.27 and <= \$5.77	\$4.52	Meets Target
6. Passengers Per Revenue Hour	8.40	>= 6.72 and <= 9.09	8.00	Meets Target
7. Passengers Per Revenue Mile	0.46	>= 0.40 and <= 0.54	0.43	Meets Target
Notes: Must meet at least 4 out of 7 Discretionary Performance Indicators				
Productivity Performance Summary:				
Service Provider Comments:				

FY 2018/19 - Table 8 -- SRTP Performance Report
Service Provider: City of Beaumont
All Routes

Performance Indicators	FY 2016/17 End of Year Actual	FY 2017/18 3rd Quarter Year-to-Date	FY 2018/19 Plan	FY 2018/19 Target	Plan Performance Scorecard (a)
Passengers	194,129	148,468	242,743	None	
Passenger Miles	927,769	709,343	1,161,519	None	
Revenue Hours	25,253.5	18,682.1	28,749.0	None	
Total Hours	28,008.7	20,372.7	31,148.0	None	
Revenue Miles	424,978.0	316,605.0	528,135.0	None	
Total Miles	453,177.0	336,634.0	556,675.0	None	
Operating Costs	\$2,385,210	\$1,876,763	\$2,670,933	None	
Passenger Revenue	\$233,847	\$179,891	\$268,724	None	
Operating Subsidy	\$2,151,364	\$1,696,872	\$2,402,209	None	
Operating Costs Per Revenue Hour	\$94.45	\$100.46	\$92.91	<= \$91.10	Fails to Meet Target
Operating Cost Per Revenue Mile	\$5.61	\$5.93	\$5.06	None	
Operating Costs Per Passenger	\$12.29	\$12.64	\$11.00	None	
Farebox Recovery Ratio	9.80%	9.59%	10.06%	>= 10.0%	Meets Target
Subsidy Per Passenger	\$11.08	\$11.43	\$9.90	>= \$9.10 and <= \$12.32	Meets Target
Subsidy Per Passenger Mile	\$2.32	\$2.39	\$2.07	>= \$1.90 and <= \$2.58	Meets Target
Subsidy Per Revenue Hour	\$85.19	\$90.83	\$83.56	>= \$72.33 and <= \$97.85	Meets Target
Subsidy Per Revenue Mile	\$5.06	\$5.36	\$4.55	>= \$4.27 and <= \$5.77	Meets Target
Passengers Per Revenue Hour	7.70	7.90	8.40	>= 6.72 and <= 9.09	Meets Target
Passengers Per Revenue Mile	0.46	0.47	0.46	>= 0.40 and <= 0.54	Meets Target

a) The Plan Performance Scorecard column is the result of comparing the FY 2018/19 Plan to the FY 2018/19 Primary Target.

**Beaumont Transit
FY 2019/2020- FY 2021/2022
Short Range Transit Plan**

Table 9 Highlights of SRTP

- **Adopt Interagency Service Agreement with City of Banning for transfer of passengers to Banning buses at connecting points for the intent of eliminating operations in City of Banning.**
- **Eliminate one bus on Route 2.**
- **Add one bus on Commuter Link 120 to increase service and frequency.**
- **Conduct a Comprehensive Operations Analysis to determine demographics and needs of residents of Beaumont as well as connecting passengers traveling on commuter links.**
- **Acquire land in industrial area of Beaumont to build CNG station and administration, maintenance and operations facility.**
- **Procure 3 cutaway vehicles for replacement.**
- **Brand and logo update.**
- **Install passenger amenities with LCTOP grant funding**
- **Continue Travel Training program to encourage the use of public transportation.**

Table 9A-Operating and Capital Data

Operating and Financial Date	FY 16/17	FY 17/18	FY 18/19 Estimate based from 3Q actuals	FY 19/20 Planned
System wide Ridership	196,377	196,430	191,811	165,316
Operating Costs per Revenue Hour	\$94.45	\$96.37	\$92.91	\$110.36

**Table 9B- Fare Revenue Calculation
(Consistent with Commission Recovery Policy)**

Revenue Source included in Farebox Calculation	FY 16/17 Audited	FY 17/18 Audited	FY 18/19 Estimate based from 3Q actuals	FY 19/20 Planned
1. Passenger Fares	219,522	234,182	225,345	281,000
2. Interest	4,475	4,984	2,811	6,200

3. General Fund Supplement	0	0	0	0
4. Measure A	0	0	0	0
5. Advertising Revenue	0	0	0	0
6. Gain on Sale of Capital Assets	0	0	0	0
7. CNG Revenue	0	0	0	0
8. Lease/Other Revenue	0	0	0	0
9. Federal Excise Tax Refund	0	0	0	0
10. Investment Income	0	0	0	0
11. CalPers CERBT	0	0	0	0
12. Fare Revenue from Exempt Routes	0	32,371	15,537	123,109
13. Other Revenues	0	0	5,363	16,899
TOTAL REVENUE For Farebox Calculation (1-13)	224,665	206,795	217,982	164,091
TOTAL OPERATING EXPENSES For Farebox Calculation	2,406,572	2,221,266	2,183,963	1,658,284
Farebox Recovery Ratio	10.72%	9.09%	10.00%	10.1%

**Legal Advertisement
NOTICE OF
PUBLIC HEARING**

The City of Beaumont hereby invites all interested parties that reside in the Pass Transit service area, to include Beaumont and Cherry Valley, to attend a public hearing on the 2019-2020 Short Range Transit Plan. The Public Hearing will be held in conjunction with the City Council Meeting scheduled for May 21, 2019 at 6:00pm in Room 5 of the Beaumont Civic and Community Center, 550 East 6th Street, Beaumont, CA 92223.

For more information, please contact Elizabeth Gibbs, Community Services Director, at (951) 769-8530.
Date: April 23, 2019

Elizabeth Gibbs
Community Services Director

Published: Record Gazette,
May 10, 2019 and May 17,
2019

Published in
The Record Gazette
No. 165017
05/10, 17, 2019

Staff Report

TO: Mayor and City Council Members

FROM: Todd Parton, City Manager

DATE: May 21, 2019

SUBJECT: Legislative Update and Official City Council Position on Legislative Matters

Background and Analysis:

Attached is the monthly legislative update provided by Townsend Public Affairs, Inc. (Townsend), the City’s lobby firm, and the California League of Cities (League) Hot Bills Report dated May 8, 2019.

The Townsend report provides an update on state and federal legislative matters. This report highlights specific legislative proposals that are consistent with the City’s legislative platform that was adopted by the City Council earlier this year.

Several pieces of proposed legislation have been identified by the League as critical, pursuant to their 2019 legislative platform. The Hot Bills report provides a summary of each bill as well as the League’s position for each. The League requests that each community consider supporting its position for those listed bills that are of import to each community. For some of these bills, the League has provided sample letters of response. These letters are included with the Hot Bills report.

Fiscal Impact:

City staff estimates that costs will range from approximately \$1,500 to \$3,000 to provide input and follow up on the various bills.

Finance Director Review: _____

Recommendation:

1. City staff recommends specific action as follows:
 - a. AB 392 Peace Officers – Deadly Force: take no specific action and continue to monitor,
 - b. AB 516 – Authority to Remove Vehicles: oppose,
 - c. AB 1332 – Sanctuary State Contracting Act: oppose,
 - d. AB 1356 – Cannabis – Local Jurisdictions: oppose,

- e. SB 13 – Accessory Dwelling Units: oppose,
- f. SB 330 – Housing Crisis Act of 2019: oppose,
- g. SB 332- Wastewater Treatment – Recycled Water: oppose, and
- h. SB 542 – Workers’ Compensation: oppose.

2. Provide additional direction to City staff.

City Manager Review: _____



Attachments:

- A. Townsend Public Affairs, Inc. – May 2019 Legislative Update
- B. California League of Cities – Hot Bills Report – 5/8/2019

MEMO

To: City of Beaumont
From: Townsend Public Affairs, Inc.
Date: May 16, 2019
Subject: April 2019 Monthly Update

SUMMARY

This memo is an overview of activities by Townsend Public Affairs (“TPA”) on work conducted on behalf of the City of Beaumont (“City”), including the following items:

- *Grants*
- *State and Federal Activities*
- *Upcoming Funding Activities*
- *Legislative Matrix*



GRANTS

Southern California Association of Governments

On March 7, 2019, the Southern California Association of Governments (SCAG) Board took action on Sustainable Communities Program (SCP) award recommendations. As part of the Green Region Initiatives, TPA worked with City staff to prepare an application for funding that would allow the City to prepare a parking strategies plan. SCAG recommended the City's application be awarded and will be included in the list of proposed projects that will be submitted to the California Transportation Commission (CTC) for final approval. We anticipate the recommendations will be placed on the agenda for the June meeting.

SB 2 Planning Grants

Senate Bill 2 directs the California Housing and Community Development Department (HCD) to use 50 percent of the revenue in the first year to establish a program that provides financial and technical assistance to local governments to update planning documents and zoning ordinances in order to streamline housing production. Eligible activities must demonstrate a nexus to accelerating housing production and may include updates to general plans, community plans, specific plans, and updates to zoning ordinances. These applications will be funded on a first come first serve basis. TPA is working with City staff to prepare an application for a much-needed zoning update.

Statewide Parks Program

TPA is currently working with City staff to identify a project for the Statewide Park Development and Community Revitalization Program. Funded under Proposition 68, this program offers competitive grants to create new recreations opportunities to underserved communities. Applications are due on August 4, 2019.

Proposition 68 – Per Capita Program

Proposition 68, passed by voters in June 2018, provided \$185 million for local park rehabilitation, creation, and improvement grants to local governments on a per capita basis. Each city is guaranteed a minimum of \$200,000 to rehabilitate or improve park access in existing parks. The California Department of Parks and Recreation is administering the Per Capita Program and has recently released draft guidelines to help cities navigate the application and award process. All projects require a 20 percent match unless the applicant serves a severely disadvantaged community, defined as having a median household income of less than 60 percent of the statewide average. A questionnaire was sent to eligible applicants and is due by June 3 to DPR.

STATE AND FEDERAL UPDATE

State Legislative Update

After the Legislature returned from Spring Recess, legislators had only five working days to pass fiscal bills out of their assigned policy committees before the April 26 deadline. This is the first step in the legislative process for bills to either move forward to their appropriations committees or “die” in their house of origin. There have been nearly 3,000 bills introduced in the first year of this two-year session and only 330 of them failed passage before the April 26 deadline. Those bills are now two-year bills and will be considered again in January 2020.

This policy committee deadline is not only the first time that bills are considered by committees, but also provides the public with their first opportunity to voice their opposition or support for a bill. As a result, Sacramento hosted a myriad of demonstrators and activists in April expressing their opinions on a variety of topics, including police use of force, vaccination exemptions, homelessness, and housing.

Below is a list of key upcoming deadlines in the Legislature:

May 17 – Last day for fiscal committees to refer bills to the floor

May 31 – Last day for bills to be passed out of their house of origin

June 15 – Budget must be passed by midnight

May Revision of the Governor’s Budget

On May 9, 2019 Governor Newsom released his May Revision budget proposal for FY 2019-20. The May Revision incorporates changes to the Governor’s January budget proposal after taking into account actual state tax revenue and a more accurate financial forecast for the upcoming fiscal years.

The January budget proposal totaled \$209.1 billion - the May Revision projects an additional \$3.2 billion of revenue. However, the Governor notes that the majority of these revenue funds are largely constitutionally obligated to fund statewide reserves (rainy day fund), debt repayment, and Prop 98 education investments, making the budget surplus levels more or less unchanged. The May Revision also forecasts slower economic growth over the next three years, a decrease from the January forecast of approximately \$1.6 billion overall by FY 2022-23.

The Governor highlighted his top budget priorities in his presentation, including additional education investment, expanding access to Medi-Cal for undocumented immigrants, and establishing The Parent’s Agenda. Other major takeaways include:

Housing & Homelessness

- An additional \$150 million for emergency housing shelters and navigation centers, bringing this year’s budget total to \$650 million. The state’s 13 largest cities will receive

\$275 million, counties will receive \$275 million, and Continuums of Care (CoCs) will receive \$100 million. The budget notes that funds are contingent on cities and counties submitting regional plans to their CoCs, which must also be approved by the state.

- The Governor's mention of his ongoing communications with cities that the state has sued, and those cities the state has threatened to sue, in this year's housing budget negotiations. The Governor said he has heard from cities that are struggling to pay for basic infrastructure such as the maintenance of roads, sidewalks, and street lights. Some cities have argued that housing investment must come with greater investment in basic infrastructure. As a result of these negotiations, \$500 million has been repurposed for the Infill Infrastructure Grant Program to provide gap funding for housing in high-density areas. This grant will be made available through the Department of Housing and Community Development (HCD).
- The alignment of local jurisdiction housing targets to the forthcoming Regional Housing Needs Assessment (RHNA). The budget also mentions that HCD will continue to develop long-term regional housing targets through a new RHNA process by 2022.

Public Safety

- An additional \$18 million one-time General Fund payment for the California Violence Intervention and Prevention Grant Program. This grant (\$27 million overall) will be available to cities to support services such as community education, diversion programs, outreach to at-risk youth, and violence reduction.

Cap & Trade

- Updates to the Cap and Trade Program. The Governor's January budget proposed \$1 billion to support programs that reduce greenhouse gas emissions – the May Revise proposes an additional \$251.1 million. Specifically:
 - Transformative Climate Communities – one-time increase of \$92 million for carbon neutral housing development.
 - Low Carbon Transportation – one-time increase of \$130 million for mitigating diesel pollution. This includes \$65 million to replace agriculture diesel equipment, \$50 million for zero-emission trucks, transit buses, and freight equipment, and \$15 million to help individuals replace high-polluting vehicles with more efficient cars and trucks.
 - Climate Smart Agriculture – one-time increase of \$20 million for healthy soils and methane reduction programs.

Emergency Preparedness, Response and Recovery

- \$769.6 million in additional funding to enhance the state's fire preparedness, including increased capacity to respond to emergency incidents and increased public safety. The May Revise also makes significant investments in the following areas which will be provided through the budget subcommittee process:
 - \$20 million one-time General Fund for a state mission tasking appropriation within the Cal OES budget. In addition, \$1.5 million and 12 positions are proposed for Cal OES to coordinate with all state agency responders as a part of

effectively managing and monitoring this appropriation given it will be responsible for the distribution of these funds. When state entities are mission tasked, some staffing costs associated with those activities are not absorbable within existing budgets, nor are these costs eligible for the California Disaster Assistance Act or Disaster Response-Emergency Operations Act funding. This proposed state mission tasking appropriation provides a resource to fund state entities for costs incurred when mission tasked, and to fund surge capacity needs of the Statewide Disaster Reserve Corps described below.

- One-time \$518,000 General Fund to reimburse cities, counties and special districts for 2018-19 **property tax losses resulting from the 2018 wildfires**. This augments the \$31.3 million proposed in the 2019-20 Governor's Budget, and subsequently added to the 2018 Budget Act by Chapter 1, Statutes of 2019 (AB 72).

The Legislature has until June 15 to consider the Governor's budget proposal and ultimately vote on a final budget. Budget Committees and Subcommittees will continue to hold hearings related to the budget over the next month, as well as incorporate its own legislative priorities in the budget. Once both the Assembly and Senate have passed their respective budgets, a Budget Conference Committee will be convened to reconcile any differences between the two budgets. Once both chambers pass a budget, it will go to the Governor's desk for approval.

Police Use of Force Legislation

After taking significant amendments in the Senate Public Safety Committee, SB 230 was legislatively linked to AB 392 (Weber), a bill that would limit the circumstances where police use of deadly force is legal. SB 230 passed out of the Assembly Appropriations Committee on May 16, 2019 and will be eligible to be heard on the Senate floor next week.

AB 392 is supported by advocates that are opposed to police use of deadly force, whereas those opposed to the bill have argued that it would make it easier to prosecute police officers for applying deadly force and exposes them to criminal liability. This bill remains in the Assembly Rules Committee.

Housing

SB 50 (Wiener), this year's comprehensive housing legislation was turned into a two-year bill on May 16, 2019 in the Senate Appropriations Committee. The author will now have the rest of the year to work on amendments that will build support for the bill.

SB 50 seeks to increase housing in high-density transit hubs throughout the state by requiring up-zoning and density minimums. The bill has been substantially amended prior to the announcement by the Senate Appropriations Committee. Prior to the bill being considered in January of 2020 there will need to be amendments that allow for increased flexibility and local control so cities can determine the housing options that are best for their communities.

SB 330 (Skinner) declares a statewide housing crisis and for a ten-year period, prohibit a city from imposing parking requirements, adjusting impact fees, imposing impact fees on affordable housing projects, and limiting new design standards based on cost. SB 330 would prohibit cities from imposing any new design standard and would lock in place nearly all fees or exactions

imposed on development projects. These fees are imposed in order to provide the public improvements and public services necessary to meet the needs of the new residents. Cities can only charge a fee to cover the cost of delivering the service. This bill passed out of the Senate Appropriations Committee on May 16, 2019. It will now go to the Senate Floor for a vote.

AB 1486 (Ting) expands surplus property requirements for both the state and local agencies. The bill also requires all local agencies to make an inventory of all lands held, owned, or controlled by it, in excess of its foreseeable needs for its governmental operations, and report this information to HCD each year. The bill also places additional requirements on cities and counties in the provisions of law that require a city or county to develop an inventory of land suitable for residential development to account for these surplus lands, and allows HCD to notify the Attorney General if a city or county is in violation of provisions of the Surplus Lands Act. This bill is opposed by the League of California Cities, California Special District's Association and California State Association of Counties. This passed out of the Assembly Appropriations Committee on May 16, 2019.

Sales Tax Legislation

On May 16, SB 531 passed off the Senate Floor with a vote of 27-8. This bill prohibits a local agency from entering into any agreement that results in a rebate of Bradley-Burns local tax revenues to a retailer in exchange for that retailer locating within that agency's jurisdiction.

Cities that focus their economic development efforts on warehouse and distribution centers view these agreements as valuable economic development tools that create employment and economic activity that can't be generated any other way. Even if one of these agreements requires a significant rebate back to a retailer, that city still may be better off because they generate more sales tax revenue than if the retailer did not locate their warehouse or distribution in their city. This bill does not apply to existing agreements and would go into effect January 1, 2002.

The bill will now go the Assembly Rules Committee for referral to a policy committee.

UPCOMING FUNDING ACTIVITY

TPA monitors and routinely sends grant opportunities that may be of interest to the City. In addition, we regularly communicate with City staff to identify potential needs and priority program areas. Below is a list of grant opportunities provided to the City and the current status of each upcoming grant program.

Upcoming Grant Programs	
<p>Senate Bill 2 Planning Grants: California Housing and Community Development Department (HCD) will provide financial and technical assistance to local governments to update planning documents and zoning ordinances in order to streamline housing production.</p>	<p>Status: First Come First Serve</p>
<p>Urban Greening Infrastructure Grant Program: Proposition 68 authorized the Legislature to appropriate \$18.5 million to the California Natural Resources Agency for competitive grants for multi-benefit green infrastructure investments in or benefiting disadvantaged or severely disadvantaged communities.</p>	<p>Status: Guidelines are currently being developed</p>
<p>Proposition 68 Per Capita Program: Funds are available from Proposition 68 for local park rehabilitation, creation, and improvement grants to local governments on a per capita basis.</p>	<p>Status: Application due Fall 2019</p>
<p>Statewide Parks Program: Funded under Proposition 68, the Statewide Park Program will fund projects that create new parks or enhance existing parks with new recreational opportunities in underserved communities</p>	<p>Status: Application due August 5, 2019</p>
<p>Storm Water Grant Program - Multi-benefit storm water management projects which may include, but shall not be limited to, green infrastructure, rainwater and storm water capture projects and storm water treatment facilities.</p>	<p>Status: Applications open Summer 2019</p>
<p>California Trails and Greenways Investment Program: 27.7 million available for trail projects. Anticipate draft guidelines and public hearings for release in Summer 2019.</p>	<p>Status: Application open Fall 2019</p>

**City of Beaumont
2019-20 Legislative Report (5/16/2019)**

AB 11

(Chiu D) Community Redevelopment Law of 2019.

Current Text: Amended: 4/11/2019 [html](#) [pdf](#)

Status: 4/25/2019-From committee: Do pass and re-refer to Com. on APPR. (Ayes 6. Noes 2.) (April 24). Re-referred to Com. on APPR.

Desk	Policy	Fiscal	Floor	Desk	Policy	Fiscal	Floor	Conf. Conc.	Enrolled	Vetoed	Chaptered
1st House				2nd House							

Summary: Current law dissolved redevelopment agencies as of February 1, 2012, and designates successor agencies to act as successor entities to the dissolved redevelopment agencies. This bill, the Community Redevelopment Law of 2019, would authorize a city or county, or two or more cities acting jointly, to propose the formation of an affordable housing and infrastructure agency by adoption of a resolution of intention that meets specified requirements, including that the resolution of intention include a passthrough provision and an override passthrough provision, as defined.

Organization Position
City of Beaumont Watch

Department

AB 14

(Rivas, Luz D) Multifamily Housing Program: homeless youths: homeless families.

Current Text: Introduced: 12/3/2018 [html](#) [pdf](#)

Status: 1/17/2019-Referred to Com. on H. & C.D.

Desk	Policy	Fiscal	Floor	Desk	Policy	Fiscal	Floor	Conf. Conc.	Enrolled	Vetoed	Chaptered
1st House				2nd House							

Summary: Would appropriate an unspecified sum from the General Fund into the Housing Rehabilitation Loan Fund to be expended under the Multifamily Housing Program to fund housing for homeless youths and homeless families in accordance with certain requirements, including that the department prioritize loans to housing projects in disadvantaged communities, as defined, and that unspecified amounts be set aside for both certain homeless youths and certain homeless families.

Organization Position
City of Beaumont Watch

Department

AB 40

(Ting D) Zero-emission vehicles: comprehensive strategy.

Current Text: Introduced: 12/3/2018 [html](#) [pdf](#)

Status: 4/26/2019-Failed Deadline pursuant to Rule 61(a)(2). (Last location was TRANS. on 1/24/2019) (May be acted upon Jan 2020)

Desk	2 year	Fiscal	Floor	Desk	Policy	Fiscal	Floor	Conf. Conc.	Enrolled	Vetoed	Chaptered
1st House				2nd House							

Summary: Would, no later than January 1, 2021, require the State Air Resources Board to develop a comprehensive strategy to ensure that the sales of new motor vehicles and new light-duty trucks in the state have transitioned fully to zero-emission vehicles, as defined, by 2040, as specified.

Organization Position
City of Beaumont Watch

Department

AB 68

(Ting D) Land use: accessory dwelling units.

Current Text: Amended: 4/3/2019 [html](#) [pdf](#)

Status: 5/16/2019-Action From APPR. SUSPENSE FILE: Do pass.

Desk	Policy	Fiscal	Floor	Desk	Policy	Fiscal	Floor	Conf. Conc.	Enrolled	Vetoed	Chaptered
1st House				2nd House							

Summary: The Planning and Zoning Law authorizes a local agency to provide, by ordinance, for the creation of accessory dwelling units in single-family and multifamily residential zones and sets forth required ordinance standards, including, among others, lot coverage. This bill would delete the provision authorizing the imposition of standards on lot coverage and would prohibit an ordinance from imposing requirements on minimum lot size.

Organization Position
City of Beaumont Watch

Department

AB 139

(Quirk-Silva D) Emergency and Transitional Housing Act of 2019.

Current Text: Amended: 4/10/2019 [html](#) [pdf](#)

Status: 5/16/2019-Action From APPR. SUSPENSE FILE: Do pass.

Desk	Policy	Fiscal	Floor	Desk	Policy	Fiscal	Floor	Conf. Conc.	Enrolled	Vetoed	Chaptered
1st House				2nd House							

Summary: Current law requires the housing element to contain specified information and analysis,

including an assessment of housing needs and an inventory of resources and constraints relevant to the meeting of those needs that includes, among other things, the identification of a zone or zones where emergency shelters are allowed as a permitted use without a conditional use or other discretionary permit. Current law requires the identified zone or zones to include sufficient capacity to accommodate the need for emergency shelter, as specified. This bill would define "sufficient capacity" for these purposes.

Organization **Position**
City of Beaumont Watch

Department

AB 147

(Burke D) Use taxes: collection: retailer engaged in business in this state: marketplace facilitators.

Current Text: Chaptered: 4/25/2019 [html](#) [pdf](#)

Status: 4/25/2019-Approved by the Governor. Chaptered by Secretary of State - Chapter 5, Statutes of 2019.

Desk	Policy	Fiscal	Floor	Desk	Policy	Fiscal	Floor	Conf. Conc.	Enrolled	Vetoed	Chaptered
1st House				2nd House							

Summary: Would specify that, on and after April 1, 2019, a retailer engaged in business in this state includes any retailer that, in the preceding calendar year or the current calendar year, has total combined sales of tangible personal property for delivery in this state by the retailer and all persons related to the retailer that exceed \$500,000. The bill would allow the California Department of Tax and Fee Administration to grant relief to certain retailers engaged in business in this state for specified interest or penalties imposed on use tax liabilities due and payable for tax reporting periods beginning April 1, 2019 and ending December 31, 2022.

Organization **Position**
City of Beaumont Watch

Department

AB 213

(Reyes D) Local government finance: property tax revenue allocations: vehicle license fee adjustments.

Current Text: Introduced: 1/15/2019 [html](#) [pdf](#)

Status: 5/16/2019-Action From APPR. SUSPENSE FILE: Do pass.

Desk	Policy	Fiscal	Floor	Desk	Policy	Fiscal	Floor	Conf. Conc.	Enrolled	Vetoed	Chaptered
1st House				2nd House							

Summary: Would, for the 2019–20 fiscal year, require the vehicle license fee adjustment amount to be the sum of the vehicle license fee adjustment amount in the 2018–19 fiscal year, the product of that sum and the percentage change in gross taxable assessed valuation within the jurisdiction of that entity between the 2018–19 fiscal year to the 2018–19 fiscal year, and the product of the amount of specified motor vehicle license fee revenues that the Controller allocated to the applicable city in July 2010 and 1.17.

Organization **Position**
City of Beaumont Watch

Department

AB 392

(Weber D) Peace officers: deadly force.

Current Text: Amended: 3/27/2019 [html](#) [pdf](#)

Status: 4/10/2019-From committee: Do pass and re-refer to Com. on RLS. (Ayes 6. Noes 2.) (April 9). Re-referred to Com. on RLS.

Desk	Policy	Fiscal	Floor	Desk	Policy	Fiscal	Floor	Conf. Conc.	Enrolled	Vetoed	Chaptered
1st House				2nd House							

Summary: Would redefine the circumstances under which a homicide by a peace officer is deemed justifiable to include when the killing is in self-defense or the defense of another, consistent with the existing legal standard for self-defense, or when the killing is necessary to prevent the escape of a fleeing felon whose immediate apprehension is necessary to prevent death or serious injury. The bill would additionally bar the use of this defense if the peace officer acted in a criminally negligent manner that caused the death, including if the officer's criminally negligent actions created the necessity for the use of deadly force.

Organization **Position**
City of Beaumont Watch

Department

AB 485

(Medina D) Local government: economic development subsidies.

Current Text: Introduced: 2/12/2019 [html](#) [pdf](#)

Status: 5/2/2019-Read third time. Passed. Ordered to the Senate. In Senate. Read first time. To Com. on RLS. for assignment.

Desk	Policy	Fiscal	Floor	Desk	Policy	Fiscal	Floor	Conf. Conc.	Enrolled	Vetoed	Chaptered
1st House				2nd House							

Summary: Current law requires each local agency, as defined, to provide specified information to the

public before approving an economic development subsidy within its jurisdiction, and to, among other things, hold hearings and report on those subsidies, as provided. Current law defines "economic development subsidy" for these purposes. This bill, on and after January 1, 2020, would similarly require each local agency to provide specified information to the public before approving an economic development subsidy for a warehouse distribution center, as defined, and to, among things, hold hearings and report on those subsidies, as provided.

Organization **Position** **Department**
 City of Beaumont Watch

AB 510

(Cooley D) Local government records: destruction of records.

Current Text: Introduced: 2/13/2019 [html](#) [pdf](#)

Status: 5/3/2019-Failed Deadline pursuant to Rule 61(a)(3). (Last location was L. GOV. on 2/21/2019) (May be acted upon Jan 2020)

Desk	2 year	Fiscal	Floor	Desk	Policy	Fiscal	Floor	Conf.	Enrolled	Vetoed	Chaptered
1st House				2nd House				Conc.			

Summary: Current law authorizes the head of a department of a county or city, or the head of a special district to destroy recordings of telephone and radio communications maintained by that county, city, or special district after 100 days if that person receives approval from the legislative body and the written consent of the agency attorney. This bill would exempt the head of a department of a county or city, or the head of a special district from these recording retention requirements if the county, city, or special district adopts a records retention policy governing recordings of routine video monitoring and recordings of telephone and radio communications.

Organization **Position** **Department**
 City of Beaumont Watch

AB 694

(Irwin D) Veterans Housing and Homeless Prevention Bond Act of 2019.

Current Text: Introduced: 2/19/2019 [html](#) [pdf](#)

Status: 5/16/2019-Action From APPR. SUSPENSE FILE: Do pass as amended.

Desk	Policy	Fiscal	Floor	Desk	Policy	Fiscal	Floor	Conf.	Enrolled	Vetoed	Chaptered
1st House				2nd House				Conc.			

Summary: Would enact the Veterans Housing and Homeless Prevention Bond Act of 2019 to authorize the issuance of bonds in an unspecified amount to provide additional funding for the VHHPA. The bill would provide for the handling and disposition of the funds in the same manner as the 2014 bond act.

Organization **Position** **Department**
 City of Beaumont Watch

AB 747

(Levine D) Planning and zoning: general plan: safety element.

Current Text: Amended: 4/1/2019 [html](#) [pdf](#)

Status: 5/2/2019-Read third time. Passed. Ordered to the Senate. In Senate. Read first time. To Com. on RLS. for assignment.

Desk	Policy	Fiscal	Floor	Desk	Policy	Fiscal	Floor	Conf.	Enrolled	Vetoed	Chaptered
1st House				2nd House				Conc.			

Summary: Would, upon the next revision of a local hazard mitigation plan on or after January 1, 2020, or beginning on or before January 1, 2021, if a local jurisdiction has not adopted a local hazard mitigation plan, require the safety element to be reviewed and updated as necessary to identify evacuation routes and their capacity, safety, and viability under a range of emergency scenarios. The bill would authorize a city or county that has adopted a local hazard mitigation plan, emergency operations plan, or other document that fulfills commensurate goals and objectives to use that information in the safety element to comply with this requirement by summarizing and incorporating by reference that other plan or document in the safety element.

Organization **Position** **Department**
 City of Beaumont Watch

AB 750

(Chen R) School safety: school resource officers.

Current Text: Amended: 3/28/2019 [html](#) [pdf](#)

Status: 4/26/2019-Failed Deadline pursuant to Rule 61(a)(2). (Last location was ED. on 3/14/2019) (May be acted upon Jan 2020)

Desk	2 year	Fiscal	Floor	Desk	Policy	Fiscal	Floor	Conf.	Enrolled	Vetoed	Chaptered
1st House				2nd House				Conc.			

Summary: Would require a school district or a charter school to hire or contract with at least one school resource officer, as defined, authorized to carry a loaded firearm, to be present at each school of the school district or charter school during regular school hours and any other time when pupils are present on campus. By imposing an additional requirement on school districts and charter schools, the bill would impose a state-mandated local program.

Organization Position Department
City of Beaumont Watch

AB 761

(Nazarian D) State armories: homeless shelters.

Current Text: Amended: 4/8/2019 [html](#) [pdf](#)

Status: 5/2/2019-Read third time. Passed. Ordered to the Senate. In Senate. Read first time. To Com. on RLS. for assignment.

Desk	Policy	Fiscal	Floor	Desk	Policy	Fiscal	Floor	Conf.	Enrolled	Vetoed	Chaptered
1st House				2nd House				Conc.			

Summary: Would authorize, at the sole discretion of the Adjutant General, the use of any armory deemed vacant by the Military Department throughout the year by the county or city in which the armory is located for the purpose of providing temporary shelter from hazardous weather conditions for homeless persons.

Organization Position Department
City of Beaumont Watch

AB 847

(Grayson D) Housing: transportation-related impact fees grant program.

Current Text: Amended: 3/27/2019 [html](#) [pdf](#)

Status: 4/26/2019-Failed Deadline pursuant to Rule 61(a)(2). (Last location was H. & C.D. on 4/1/2019)(May be acted upon Jan 2020)

Desk	2 year	Fiscal	Floor	Desk	Policy	Fiscal	Floor	Conf.	Enrolled	Vetoed	Chaptered
1st House				2nd House				Conc.			

Summary: Would require the Department of Housing and Community Development , upon appropriation by the Legislature, to establish a competitive grant program to award grants to cities and counties to offset up to 100% of any transportation-related impact fees exacted upon a qualifying housing development project, as defined, by the local jurisdiction.

Organization Position Department
City of Beaumont Watch

AB 1096

(Melendez R) Firearms: concealed carry licenses.

Current Text: Introduced: 2/21/2019 [html](#) [pdf](#)

Status: 4/26/2019-Failed Deadline pursuant to Rule 61(a)(2). (Last location was PUB. S. on 3/7/2019) (May be acted upon Jan 2020)

Desk	2 year	Fiscal	Floor	Desk	Policy	Fiscal	Floor	Conf.	Enrolled	Vetoed	Chaptered
1st House				2nd House				Conc.			

Summary: Would require the sheriff of a county, or the chief or other head of a municipal police department, to issue a license to carry a concealed handgun or to carry a loaded and exposed handgun, as specified, if good cause exists for the issuance and the applicant is of good moral character and satisfies certain other criteria.

Organization Position Department
City of Beaumont Watch

AB 1184

(Gloria D) Public records: writing transmitted by electronic mail: retention.

Current Text: Amended: 4/24/2019 [html](#) [pdf](#)

Status: 5/16/2019-Action From APPR. SUSPENSE FILE: Do pass as amended.

Desk	Policy	Fiscal	Floor	Desk	Policy	Fiscal	Floor	Conf.	Enrolled	Vetoed	Chaptered
1st House				2nd House				Conc.			

Summary: Would, unless a longer retention period is required by statute or regulation, require a public agency for purposes of the California Public Records Act to retain and preserve for at least 2 years every writing containing information relating to the conduct of the public's business prepared, owned, or used by any public agency that is transmitted by electronic mail or other similar messaging system.

Organization Position Department
City of Beaumont Watch

AB 1266

(Rivas, Robert D) Traffic control devices: bicycles.

Current Text: Amended: 4/2/2019 [html](#) [pdf](#)

Status: 5/14/2019-In Senate. Read first time. To Com. on RLS. for assignment.

Desk	Policy	Fiscal	Floor	Desk	Policy	Fiscal	Floor	Conf.	Enrolled	Vetoed	Chaptered
1st House				2nd House				Conc.			

Summary: Current law authorizes the Department of Transportation or local authorities to erect official traffic control devices within or adjacent to intersections of highways under their respective jurisdictions to regulate or prohibit turning movements at those intersections. When a turn is required,

existing law requires the erection of a sign giving notice of that requirement, except as specified. Current law prohibits a driver of a vehicle from disobeying the directions of a traffic control device erected pursuant to that provision. This bill would exempt from the prohibition described above drivers of bicycles traveling straight through an intersection, if there is a striped bike lane between the right-turn only lane and the adjacent through lane and pavement markings ensuring that bicycles may travel to the left of vehicles turning right.

Organization **Position**
City of Beaumont Watch

Department

AB 1486 (Ting D) Local agencies: surplus land.

Current Text: Amended: 4/11/2019 [html](#) [pdf](#)

Status: 5/16/2019-Action From APPR. SUSPENSE FILE: Do pass as amended.

Desk	Policy	Fiscal	Floor	Desk	Policy	Fiscal	Floor	Conf. Conc.	Enrolled	Vetoed	Chaptered
1st House				2nd House							

Summary: Current law prescribes requirements for the disposal of surplus land by a local agency. Current law defines "local agency" for these purposes as every city, county, city and county, and district, including school districts of any kind or class, empowered to acquire and hold real property. This bill would expand the definition of "local agency" to include sewer, water, utility, and local and regional park districts, joint powers authorities, successor agencies to former redevelopment agencies, housing authorities, and other political subdivisions of this state and any instrumentality thereof that is empowered to acquire and hold real property, thereby requiring these entities to comply with these requirements for the disposal of surplus land. The bill would specify that the term "district" includes all districts within the state, and that this change is declaratory of existing law.

Organization **Position**
City of Beaumont Watch

Department

AB 1487 (Chiu D) San Francisco Bay area: housing development: financing.

Current Text: Amended: 4/29/2019 [html](#) [pdf](#)

Status: 5/16/2019-Action From APPR. SUSPENSE FILE: Do pass as amended.

Desk	Policy	Fiscal	Floor	Desk	Policy	Fiscal	Floor	Conf. Conc.	Enrolled	Vetoed	Chaptered
1st House				2nd House							

Summary: Current law provides for the establishment of various special districts that may support and finance housing development, including affordable housing special beneficiary districts that are authorized to promote affordable housing development with certain property tax revenues that a city or county would otherwise be entitled to receive. This bill, the San Francisco Bay Area Regional Housing Finance Act, would establish the Housing Alliance for the Bay Area (hereafter the entity) and would state that the entity's purpose is to increase affordable housing in the San Francisco Bay area, as defined, by providing for enhanced funding and technical assistance at a regional level for tenant protection, affordable housing preservation, and new affordable housing production.

Organization **Position**
City of Beaumont Watch

Department

AB 1708 (Rodriguez D) Emergency response: trauma kits.

Current Text: Amended: 4/10/2019 [html](#) [pdf](#)

Status: 5/16/2019-Action From APPR. SUSPENSE FILE: Held in APPR..

Desk	Policy	Fiscal	Floor	Desk	Policy	Fiscal	Floor	Conf. Conc.	Enrolled	Vetoed	Chaptered
1st House				2nd House							

Summary: Current law exempts from civil liability any person who, in good faith and not for compensation, renders emergency medical or nonmedical care or assistance at the scene of an emergency other than an act or omission constituting gross negligence or willful or wanton misconduct. Current law exempts public or private organizations that sponsor, authorize, support, finance, or supervise the training of people, or certifies those people in emergency medical services, from liability for civil damages alleged to result from those training programs. This bill would define "trauma kit" to mean a first aid response kit that contains specified items, including, among other things, at least 2 tourniquets.

Organization **Position**
City of Beaumont Watch

Department
Police
Department

AB 1713 (Burke D) Vehicles: driving under the influence.

Current Text: Introduced: 2/22/2019 [html](#) [pdf](#)

Status: 4/26/2019-Failed Deadline pursuant to Rule 61(a)(2). (Last location was PUB. S. on 3/18/2019) (May be acted upon Jan 2020)

Desk	2 year	Fiscal	Floor	Desk	Policy	Fiscal	Floor	Conf. Conc.	Enrolled	Vetoed	Chaptered
1st House				2nd House							

Summary: Current law prohibits a person from driving a motor vehicle when the person has 0.08 percent or more, by weight, of alcohol in their blood. This bill would instead prohibit a person from driving a motor vehicle when the person has 0.05 percent or more, by weight, of alcohol in their blood.

Organization Position Department
City of Beaumont Watch

ACA 1

(Aquiar-Curry D) Local government financing: affordable housing and public infrastructure: voter approval.

Current Text: Amended: 3/18/2019 [html](#) [pdf](#)

Status: 5/16/2019-Action From APPR. SUSPENSE FILE: Be adopted.

Desk	Policy	Fiscal	Floor	Desk	Policy	Fiscal	Floor	Conf.	Enrolled	Vetoed	Chaptered
1st House				2nd House				Conc.			

Summary: The California Constitution prohibits the ad valorem tax rate on real property from exceeding 1% of the full cash value of the property, subject to certain exceptions. This measure would create an additional exception to the 1% limit that would authorize a city, county, city and county, or special district to levy an ad valorem tax to service bonded indebtedness incurred to fund the construction, reconstruction, rehabilitation, or replacement of public infrastructure, affordable housing, or permanent supportive housing, or the acquisition or lease of real property for those purposes, if the proposition proposing that tax is approved by 55% of the voters of the city, county, or city and county, as applicable, and the proposition includes specified accountability requirements.

Organization Position Department
City of Beaumont Watch

ACA 13

(Obernolte R) Local sales taxes: online sales.

Current Text: Introduced: 3/26/2019 [html](#) [pdf](#)

Status: 3/28/2019-Introduced measure version corrected.

Desk	Policy	Fiscal	Floor	Desk	Policy	Fiscal	Floor	Conf.	Enrolled	Vetoed	Chaptered
1st House				2nd House				Conc.			

Summary: Would provide that, on and after January 1, 2021, for the purpose of distributing the revenues derived under a sales tax imposed pursuant to the Bradley-Burns Uniform Local Sales and Use Tax Law, the retail sale of tangible personal property by a qualified retailer, as defined, that is transacted online is instead consummated at the point of the delivery of that tangible personal property to the purchaser's address or to any other delivery address designated by the purchaser.

Organization Position Department
City of Beaumont Watch

SB 4

(McGuire D) Housing.

Current Text: Amended: 4/10/2019 [html](#) [pdf](#)

Status: 4/26/2019-Failed Deadline pursuant to Rule 61(a)(2). (Last location was GOV. & F. on 4/2/2019) (May be acted upon Jan 2020)

Desk	2 year	Fiscal	Floor	Desk	Policy	Fiscal	Floor	Conf.	Enrolled	Vetoed	Chaptered
1st House				2nd House				Conc.			

Summary: Would authorize a development proponent of a neighborhood multifamily project or eligible transit-oriented development (TOD) project located on an eligible parcel to submit an application for a streamlined, ministerial approval process that is not subject to a conditional use permit. The bill would define a "neighborhood multifamily project" to mean a project to construct a multifamily unit of up to 2 residential dwelling units in a nonurban community, as defined, or up to 4 residential dwelling units in an urban community, as defined, that meets local height, setback, and lot coverage zoning requirements as they existed on July 1, 2019.

Organization Position Department
City of Beaumont

SB 5

(Beall D) Affordable Housing and Community Development Investment Program.

Current Text: Amended: 4/23/2019 [html](#) [pdf](#)

Status: 5/10/2019-Set for hearing May 16.

Desk	Policy	Fiscal	Floor	Desk	Policy	Fiscal	Floor	Conf.	Enrolled	Vetoed	Chaptered
1st House				2nd House				Conc.			

Summary: Would establish in state government the Affordable Housing and Community Development Investment Program, which would be administered by the Affordable Housing and Community Development Investment Committee. The bill would authorize a city, county, city and county, joint powers agency, enhanced infrastructure financing district, affordable housing authority, community revitalization and investment authority, transit village development district, or a combination of those entities, to apply to the Affordable Housing and Community Development Investment Committee to participate in the program and would authorize the committee to approve or deny plans for projects

meeting specific criteria.

Organization Position
City of Beaumont

Department

SB 6

(Beall D) Residential development: available land.

Current Text: Amended: 4/23/2019 [html](#) [pdf](#)

Status: 5/10/2019-Set for hearing May 16.

Desk	Policy	Fiscal	Floor	Desk	Policy	Fiscal	Floor	Conf. Conc.	Enrolled	Vetoed	Chaptered
1st House				2nd House							

Summary: Would require the Department of Housing and Community Development to furnish the Department of General Services with a list of local lands suitable and available for residential development as identified by a local government as part of the housing element of its general plan. The bill would require the Department of General Services to create a database of that information and information regarding state lands determined or declared excess and to make this database available and searchable by the public by means of a link on its internet website.

Organization Position
City of Beaumont Watch

Department

SB 18

(Skinner D) Keep Californians Housed Act.

Current Text: Amended: 4/30/2019 [html](#) [pdf](#)

Status: 5/16/2019-Action From APPR. SUSPENSE FILE: Do pass as amended.

Desk	Policy	Fiscal	Floor	Desk	Policy	Fiscal	Floor	Conf. Conc.	Enrolled	Vetoed	Chaptered
1st House				2nd House							

Summary: Current law establishes the Department of Consumer Affairs (DCA) under the control of a civil executive officer known as the Director of Consumer Affairs. Current law requires, among other things, that the director provide for the establishment of a comprehensive library of books, documents, studies, and other materials relating to consumers and consumer problems. This bill, no later than January 1, 2021, would require DCA to publish on its internet website, and to biannually update, a guide to all state laws pertaining to landlords and the landlord-tenant relationship.

Organization Position
City of Beaumont Watch

Department

SB 45

(Allen D) Wildfire, Drought, and Flood Protection Bond Act of 2020.

Current Text: Amended: 4/4/2019 [html](#) [pdf](#)

Status: 5/1/2019-May 6 set for first hearing canceled at the request of author.

Desk	Policy	Fiscal	Floor	Desk	Policy	Fiscal	Floor	Conf. Conc.	Enrolled	Vetoed	Chaptered
1st House				2nd House							

Summary: Would enact the Wildfire, Drought, and Flood Protection Bond Act of 2020, which, if approved by the voters, would authorize the issuance of bonds in the amount of \$4,300,000,000 pursuant to the State General Obligation Bond Law to finance projects to restore fire damaged areas, reduce wildfire risk, create healthy forest and watersheds, reduce climate impacts on urban areas and vulnerable populations, protect water supply and water quality, protect rivers, lakes, and streams, reduce flood risk, protect fish and wildlife from climate impacts, improve climate resilience of agricultural lands, and protect coastal lands and resources.

Organization Position
City of Beaumont Watch

Department

SB 50

(Wiener D) Planning and zoning: housing development: incentives.

Current Text: Amended: 5/1/2019 [html](#) [pdf](#)

Status: 5/16/2019-Action From APPR. SUSPENSE FILE: Held in APPR..

Desk	Policy	Fiscal	Floor	Desk	Policy	Fiscal	Floor	Conf. Conc.	Enrolled	Vetoed	Chaptered
1st House				2nd House							

Summary: Would authorize a development proponent of a neighborhood multifamily project located on an eligible parcel to submit an application for a streamlined, ministerial approval process that is not subject to a conditional use permit. The bill would define a "neighborhood multifamily project" to mean a project to construct a multifamily structure on vacant land, or to convert an existing structure that does not require substantial exterior alteration into a multifamily structure, consisting of up to 4 residential dwelling units and that meets local height, setback, and lot coverage zoning requirements as they existed on July 1, 2019.

Organization Position
City of Beaumont

Department

SB 127

(Wiener D) Transportation funding: active transportation: complete streets.

Current Text: Amended: 4/30/2019 [html](#) [pdf](#)

Status: 5/16/2019-Action From APPR. SUSPENSE FILE: Do pass as amended.

Desk	Policy	Fiscal	Floor	Desk	Policy	Fiscal	Floor	Conf. Conc.	Enrolled	Vetoed	Chaptered
1st House				2nd House							

Summary: Would establish a Division of Active Transportation within the Department of Transportation and require that an undersecretary of the Transportation Agency be assigned to give attention to active transportation program matters to guide progress toward meeting the department's active transportation program goals and objectives. The bill would require the California Transportation Commission to give high priority to increasing safety for pedestrians and bicyclists and to the implementation of bicycle and pedestrian facilities.

Organization **Position**
City of Beaumont Watch

Department

SB 128

(Beall D) Enhanced infrastructure financing districts: bonds: issuance.

Current Text: Amended: 3/21/2019 [html](#) [pdf](#)

Status: 5/2/2019-Referred to Com. on L. GOV.

Desk	Policy	Fiscal	Floor	Desk	Policy	Fiscal	Floor	Conf. Conc.	Enrolled	Vetoed	Chaptered
1st House				2nd House							

Summary: Current law authorizes the legislative body of a city or a county to establish an enhanced infrastructure financing district, with a governing body referred to as a public financing authority, to finance public capital facilities or other specified projects of communitywide significance. Current law requires a public financing authority to adopt an infrastructure financing plan and hold a public hearing on the plan, as specified. Current law authorizes the public financing authority to issue bonds for these purposes upon approval by 55% of the voters voting on a proposal to issue the bonds. Current law requires the proposal submitted to the voters by the public financing authority and the resolution for the issuance of bonds following approval by the voters to include specified information regarding the bond issuance. This bill would instead authorize the public financing authority to issue bonds for these purposes without submitting a proposal to the voters.

Organization **Position**
City of Beaumont Watch

Department

SB 144

(Mitchell D) Criminal fees.

Current Text: Amended: 3/27/2019 [html](#) [pdf](#)

Status: 5/16/2019-Action From APPR. SUSPENSE FILE: Do pass as amended.

Desk	Policy	Fiscal	Floor	Desk	Policy	Fiscal	Floor	Conf. Conc.	Enrolled	Vetoed	Chaptered
1st House				2nd House							

Summary: Current law imposes various fees contingent upon a criminal arrest, prosecution, or conviction for the cost of administering the criminal justice system, including administering probation and diversion programs, collecting restitution orders, processing arrests and citations, administering drug testing, incarcerating inmates, facilitating medical visits, and sealing or expunging criminal records. This bill would repeal the authority to collect these fees, among others. The bill would make the unpaid balance of any court-imposed costs unenforceable and uncollectible and would require any portion of a judgment imposing those costs to be vacated.

Organization **Position**
City of Beaumont Watch

Department

SB 200

(Monning D) Safe and Affordable Drinking Water Fund.

Current Text: Amended: 5/7/2019 [html](#) [pdf](#)

Status: 5/16/2019-Action From APPR. SUSPENSE FILE: Do pass as amended.

Desk	Policy	Fiscal	Floor	Desk	Policy	Fiscal	Floor	Conf. Conc.	Enrolled	Vetoed	Chaptered
1st House				2nd House							

Summary: Would establish the Safe and Affordable Drinking Water Fund in the State Treasury to help water systems provide an adequate and affordable supply of safe drinking water in both the near and the long term. The bill would authorize the board to provide for the deposit into the fund of federal contributions, voluntary contributions, gifts, grants, and bequests and would provide that moneys in the fund are available, upon appropriation by the Legislature, to the board to fund grants, loans, contracts, or services to assist eligible recipients.

Organization **Position**
City of Beaumont Watch

Department

SB 230

(Caballero D) Law enforcement: use of deadly force: training: policies.

Current Text: Amended: 4/30/2019 [html](#) [pdf](#)

Status: 5/16/2019-Action From APPR. SUSPENSE FILE: Do pass.

Desk	Policy	Fiscal	Floor	Desk	Policy	Fiscal	Floor	Conf. Conc.	Enrolled	Vetoed	Chaptered
1st House				2nd House							

Summary: Would require each law enforcement agency to maintain a policy that provides guidelines on the use of force, utilizing deescalation techniques and other alternatives to force when feasible, specific guidelines for the application of deadly force, and factors for evaluating and reviewing all use of force incidents, among other things. The bill would require each agency to make their use of force policy accessible to the public. By imposing additional duties on local agencies, this bill would create a state-mandated local program.

Organization Position
City of Beaumont Watch

Department

SB 280

(Jackson D) Older adults and persons with disabilities: fall prevention.

Current Text: Amended: 4/10/2019 [html](#) [pdf](#)

Status: 5/10/2019-Set for hearing May 16.

Desk	Policy	Fiscal	Floor	Desk	Policy	Fiscal	Floor	Conf. Conc.	Enrolled	Vetoed	Chaptered
1st House				2nd House							

Summary: The Mello-Granlund Older Californians Act establishes the California Department of Aging, and sets forth its duties and powers, including, among other things, entering into a contract for the development of information and materials to educate Californians on the concept of "aging in place" and the benefits of home modification. Current law also establishes the Senior Housing Information and Support Center within the department for the purpose of providing information and training relating to available innovative resources and senior services, and housing options and home modification alternatives designed to support independent living or living with family. This bill would repeal those provisions relating to the department's provision of information on housing and home modifications for seniors.

Organization Position
City of Beaumont Watch

Department

SB 330

(Skinner D) Housing Crisis Act of 2019.

Current Text: Amended: 5/7/2019 [html](#) [pdf](#)

Status: 5/16/2019-Action From APPR. SUSPENSE FILE: Do pass as amended.

Desk	Policy	Fiscal	Floor	Desk	Policy	Fiscal	Floor	Conf. Conc.	Enrolled	Vetoed	Chaptered
1st House				2nd House							

Summary: The The Housing Accountability Act requires a local agency that proposes to disapprove a housing development project that complies with applicable, objective general plan and zoning standards and criteria that were in effect at the time the application was deemed to be complete, or to approve it on the condition that it be developed at a lower density, to base its decision upon written findings supported by substantial evidence on the record that specified conditions exist, and places the burden of proof on the local agency to that effect. The act requires a court to impose a fine on a local agency under certain circumstances and requires that the fine be at least \$10,000 per housing unit in the housing development project on the date the application was deemed complete. This bill would, until January 1, 2030, specify that an application is deemed complete for these purposes if a preliminary application was submitted, as specified.

Organization Position
City of Beaumont Watch

Department

SB 531

(Glazer D) Local agencies: retailers.

Current Text: Amended: 4/29/2019 [html](#) [pdf](#)

Status: 5/16/2019-Action From THIRD READING: Passed Senate to ASSEMBLY.

Desk	Policy	Fiscal	Floor	Desk	Policy	Fiscal	Floor	Conf. Conc.	Enrolled	Vetoed	Chaptered
1st House				2nd House							

Summary: Would prohibit, on or after January 1, 2020, a local agency from entering into any form of agreement that would result, directly or indirectly, in the payment, transfer, diversion, or rebate of Bradley-Burns local tax revenues to any retailer, as defined, in exchange for the retailer locating or continuing to maintain a place of business that serves as the place of sale, as defined, within the territorial jurisdiction of the local agency if that place of business would generate revenue, from the sale of tangible property delivered to and received by the purchaser in the territorial jurisdiction of another local agency, for the local agency under the Bradley-Burns Uniform Local Sales and Use Tax Law.

Organization Position
City of Beaumont Watch

Department

SB 532

(Portantino D) Redevelopment: City of Glendale: bond proceeds: affordable housing.

Current Text: Amended: 4/24/2019 [html](#) [pdf](#)

Status: 5/16/2019-Action From APPR. SUSPENSE FILE: Do pass.

Desk	Policy	Fiscal	Floor	Desk	Policy	Fiscal	Floor	Conf. Conc.	Enrolled	Vetoed	Chaptered
1st House				2nd House							

Summary: Current law requires remaining bond proceeds that cannot be spent pursuant to specified requirements of any successor agency that has been issued a finding of completion to be used at the earliest possible date to defease the bonds or to purchase those same outstanding bonds on the open market for cancellation. This bill, notwithstanding the requirement that the remaining bond proceeds be used to defease the bonds or to purchase those same outstanding bonds on the open market for cancellation, would authorize the successor agency in the City of Glendale to use the remaining bond proceeds for the purposes predevelopment, development, acquisition, rehabilitation, and preservation of affordable housing, as defined.

Organization Position Department
City of Beaumont Watch

SB 542

(Stern D) Workers' compensation.

Current Text: Introduced: 2/22/2019 [html](#) [pdf](#)

Status: 5/16/2019-Action From APPR. SUSPENSE FILE: Do pass.

Desk	Policy	Fiscal	Floor	Desk	Policy	Fiscal	Floor	Conf.	Enrolled	Vetoed	Chaptered
1st House				2nd House				Conc.			

Summary: Would provide that in the case of certain state and local firefighting personnel and peace officers, the term "injury" also includes a mental health condition or mental disability that results in a diagnosis of post-traumatic stress or mental health disorder that develops or manifests itself during a period in which the firefighting member or peace officer is in the service of the department or unit. These provisions would apply to claims for benefits filed or pending on or after January 1, 2017.

Organization Position Department
City of Beaumont Watch
Police Department

SB 625

(Hill D) Party buses: cannabis.

Current Text: Introduced: 2/22/2019 [html](#) [pdf](#)

Status: 5/2/2019-Read third time. Passed. (Ayes 38. Noes 0.) Ordered to the Assembly. In Assembly. Read first time. Held at Desk.

Desk	Policy	Fiscal	Floor	Desk	Policy	Fiscal	Floor	Conf.	Enrolled	Vetoed	Chaptered
1st House				2nd House				Conc.			

Summary: Current law prohibits a passenger in a motor vehicle being driven upon a highway from drinking any alcoholic beverage or smoking or ingesting any cannabis product. Current law exempts passengers in any bus, taxicab, or limousine, as specified, from this prohibition. This bill would instead exempt the ingestion of cannabis products by a passenger in bus, taxicab, or limousine only if there are no passengers under 21 years of age present and the driver is sealed off from the passenger compartment, as specified.

Organization Position Department
City of Beaumont Watch

SB 725

(Rubio D) Veterans rental housing.

Current Text: Introduced: 2/22/2019 [html](#) [pdf](#)

Status: 5/16/2019-Action From APPR. SUSPENSE FILE: Do pass.

Desk	Policy	Fiscal	Floor	Desk	Policy	Fiscal	Floor	Conf.	Enrolled	Vetoed	Chaptered
1st House				2nd House				Conc.			

Summary: Current law creates the Veterans Housing and Homeless Prevention Act of 2014, to provide for the acquisition, construction, rehabilitation, and preservation of affordable multifamily supportive housing, affordable transitional housing, affordable rental housing, or related facilities for veterans and their families to allow veterans to access and maintain housing stability. This bill would require the department to establish a rental housing assistance program to provide financial assistance to veterans seeking rental housing, based on the needs of the veterans.

Organization Position Department
City of Beaumont Watch

SCA 1

(Allen D) Public housing projects.

Current Text: Introduced: 12/3/2018 [html](#) [pdf](#)

Status: 3/20/2019-Referred to Coms. on HOUSING, E. & C.A., and APPR.

Desk	Policy	Fiscal	Floor	Desk	Policy	Fiscal	Floor	Conf.	Enrolled	Vetoed	Chaptered
1st House				2nd House				Conc.			

Summary: The California Constitution prohibits the development, construction, or acquisition of a low-rent housing project, as defined, in any manner by any state public body until a majority of the qualified electors of the city, town, or county in which the development, construction, or acquisition of the low-rent housing project is proposed approve the project by voting in favor at an election, as specified. This measure would repeal these provisions.

Organization **Position**
City of Beaumont Watch

Department

Total Measures: 43
Total Tracking Forms: 43

League of CA Cities

Hot Bills List

and Sample Position Letters

**Hot Bills
5/8/2019**

AB 213 (Reyes D) Local government finance: property tax revenue allocations: vehicle license fee adjustments.

Status: 4/10/2019-In committee: Set, first hearing. Referred to APPR. suspense file.

Desk	Policy	Fiscal	Floor	Desk	Policy	Fiscal	Floor	Conf. Conc.	Enrolled	Vetoed	Chaptered
1st House				2nd House							

Summary:

Would, for the 2019–20 fiscal year, require the vehicle license fee adjustment amount to be the sum of the vehicle license fee adjustment amount in the 2018–19 fiscal year, the product of that sum and the percentage change in gross taxable assessed valuation within the jurisdiction of that entity between the 2018–19 fiscal year to the 2018–19 fiscal year, and the product of the amount of specified motor vehicle license fee revenues that the Controller allocated to the applicable city in July 2010 and 1.17.

Primary Lobbyist: Carrigg, Dan
League Position: Support
Hot/Priority: Hot
Policy Committee (primary): Revenue and Taxation

AB 392 (Weber D) Peace officers: deadly force.

Status: 4/10/2019-From committee: Do pass and re-refer to Com. on RLS. (Ayes 6. Noes 2.) (April 9). Re-referred to Com. on RLS.

Desk	Policy	Fiscal	Floor	Desk	Policy	Fiscal	Floor	Conf. Conc.	Enrolled	Vetoed	Chaptered
1st House				2nd House							

Summary:

Would redefine the circumstances under which a homicide by a peace officer is deemed justifiable to include when the killing is in self-defense or the defense of another, consistent with the existing legal standard for self-defense, or when the killing is necessary to prevent the escape of a fleeing felon whose immediate apprehension is necessary to prevent death or serious injury. The bill would additionally bar the use of this defense if the peace officer acted in a criminally negligent manner that caused the death, including if the officer’s criminally negligent actions created the necessity for the use of deadly force.

Primary Lobbyist: Harvey, Charles
League Position: Oppose
Hot/Priority: Hot
Policy Committee (primary): Public Safety

AB 429 (Nazarian D) Seismically vulnerable buildings: inventory.

Status: 4/24/2019-In committee: Set, first hearing. Referred to APPR. suspense file.

Desk	Policy	Fiscal	Floor	Desk	Policy	Fiscal	Floor	Conf. Conc.	Enrolled	Vetoed	Chaptered
1st House				2nd House							

Summary:

Current law establishes a program within all cities and all counties and portions thereof located within seismic zone 4, as defined, to identify all potentially hazardous buildings and to establish a mitigation program for these buildings. This bill would require the Alfred E. Alquist Seismic Safety Commission, by specified deadlines, to identify funding and develop a bidding process for hiring a third-party contractor to create an inventory of potentially vulnerable buildings, as defined. The bill would require the third-party contractor, in conjunction with the commission, by July 1, 2022, to develop a statewide inventory of potentially seismically vulnerable buildings in 29 specified counties in California using information developed by local jurisdictions pursuant to the above-described provisions.

Primary Lobbyist: Berdugo, Rony
League Position: Support
Hot/Priority: Hot
Policy Committee (primary): Transportation, Communications and Public Works

AB 516 (Chiu D) Authority to remove vehicles.

Status: 5/2/2019-Read second time. Ordered to Consent Calendar.

Desk	Policy	Fiscal	Floor	Desk	Policy	Fiscal	Floor	Conf. Conc.	Enrolled	Vetoed	Chaptered
1st House				2nd House							

Summary:

Current law authorizes a peace officer and specified public employees, as an alternative to removal of a vehicle, to immobilize the vehicle with a device designed and manufactured for that purpose, if, among other circumstances, the vehicle is found upon a highway or public lands by the peace officer or employee and it is known to have been issued 5 or more notices of parking violations that are delinquent because the owner or person in control of the vehicle has not responded to the appropriate agency within a designated time period. This bill would delete the authority of a peace officer or public employee, as appropriate, to remove or immobilize a vehicle under those circumstances.

Primary Lobbyist: Berdugo, Rony

League Position: Oppose

Hot/Priority: Hot

Policy Committee (primary): Transportation, Communications and Public Works

AB 849 (Bonta D) Elections: local redistricting.

Status: 4/25/2019-From committee: Do pass and re-refer to Com. on APPR. (Ayes 6. Noes 2.) (April 24). Re-referred to Com. on APPR.

Desk	Policy	Fiscal	Floor	Desk	Policy	Fiscal	Floor	Conf. Conc.	Enrolled	Vetoed	Chaptered
1st House				2nd House							

Summary:

Current law establishes criteria and procedures pursuant to which local jurisdictions, including cities, counties, special districts, school districts, community college districts, and county boards of education, adjust or adopt district, division, or trustee area boundaries, as applicable, for the purpose of electing members of the local jurisdiction's governing body. This bill would revise and recast these provisions. The bill would require the governing body of each local jurisdiction described above to adopt new district, division, or trustee area boundaries after each federal decennial census, except as specified.

Primary Lobbyist: Hutchings, Dane

League Position: Oppose

Hot/Priority: Hot

Policy Committee (primary): Governance, Transparency, and Labor Relations

AB 1112 (Friedman D) Shared mobility devices: local regulation.

Status: 5/8/2019-Action From SECOND READING: Read second time.To THIRD READING.

Desk	Policy	Fiscal	Floor	Desk	Policy	Fiscal	Floor	Conf. Conc.	Enrolled	Vetoed	Chaptered
1st House				2nd House							

Summary:

Current law generally regulates the operation of bicycles, electric bicycles, motorized scooters, and electrically motorized boards. Current law allows local authorities to regulate the registration, parking, and operation of bicycles and motorized scooters in a manner that does not conflict with state law. This bill would define a "shared mobility device" as a bicycle, electric bicycle, motorized scooter, electrically motorized board, or other similar personal transportation device, that is made available to the public for shared use and transportation, as provided.

Primary Lobbyist: Berdugo, Rony

League Position: Oppose

Hot/Priority: Hot

Policy Committee (primary): Transportation, Communications and Public Works

AB 1190 (Irwin D) Unmanned aircraft: state and local regulation: limitations.

Status: 5/2/2019-Read second time. Ordered to third reading.

Desk	Policy	Fiscal	Floor	Desk	Policy	Fiscal	Floor	Conf. Conc.	Enrolled	Vetoed	Chaptered
1st House				2nd House							

Summary:

Would, among other things, prohibit a state or local agency from adopting any law or regulation that bans the operation of an unmanned aircraft system. The bill would also authorize a local agency to adopt regulations to enforce FAA regulations regarding the operation of unmanned aircraft systems and would authorize local agencies to regulate the operation of unmanned aircraft and unmanned aircraft systems within their jurisdictions, as specified. The bill would also authorize a local agency to require an unmanned aircraft operator to provide proof of federal, state, or local registration to licensing or enforcement officials.

Primary Lobbyist: Harvey, Charles

League Position: Support
Hot/Priority: Hot
Policy Committee (primary): Public Safety

AB 1286 (Muratsuchi D) Shared mobility devices: agreements.

Status: 5/2/2019-Read second time. Ordered to third reading.

Desk	Policy	Fiscal	Floor	Desk	Policy	Fiscal	Floor	Conf. Conc.	Enrolled	Vetoed	Chaptered
1st House				2nd House							

Summary:

Would require a shared mobility service provider, as defined, to enter into an agreement with, or obtain a permit from, the city or county with jurisdiction over the area of use. The bill would require that the provider maintain a specified amount of commercial general liability insurance and would prohibit the provider from including specified provisions in a user agreement before distributing a shared mobility device within that jurisdiction. The bill would define shared mobility device to mean an electrically motorized board, motorized scooter, electric bicycle, bicycle, or other similar personal transportation device, except as provided.

Primary Lobbyist: Berdugo, Rony
League Position: Sponsor
Hot/Priority: Hot
Policy Committee (primary): Transportation, Communications and Public Works

AB 1332 (Bonta D) Sanctuary State Contracting and Investment Act.

Status: 5/8/2019-Action From APPR.: To APPR. SUSPENSE FILE.

Desk	Policy	Fiscal	Floor	Desk	Policy	Fiscal	Floor	Conf. Conc.	Enrolled	Vetoed	Chaptered
1st House				2nd House							

Summary:

Current law requires law enforcement agencies to report to the Department of Justice annually regarding transfers of persons to immigration authorities and requires the Attorney General to publish guidance, audit criteria, and training recommendations regarding state and local law enforcement databases, for purposes of limiting the availability of information for immigration enforcement, as specified. This bill, the Sanctuary State Contracting Act, would, among other things, require the Department of Justice, commencing on January 1, 2020, and quarterly thereafter, to publish a list on its internet website, based on specified criteria, of each person or entity that, in the opinion of the Department of Justice, is providing data broker, extreme vetting, or detention facilities support to any federal immigration agency, as specified.

Primary Lobbyist: Hutchings, Dane
League Position: Oppose
Hot/Priority: Hot
Policy Committee (primary): Governance, Transparency, and Labor Relations

AB 1356 (Ting D) Cannabis: local jurisdictions: retail commercial cannabis activity.

Status: 5/8/2019-Action From APPR.: To APPR. SUSPENSE FILE.

Desk	Policy	Fiscal	Floor	Desk	Policy	Fiscal	Floor	Conf. Conc.	Enrolled	Vetoed	Chaptered
1st House				2nd House							

Summary:

Would, if more than 50% of the electorate of a local jurisdiction voted in favor of AUMA, require a local jurisdiction to issue a minimum number of local licenses authorizing specified retail cannabis commercial activity within that jurisdiction that would be permitted by a retailer license issued under MAUCRSA.

Primary Lobbyist: Harvey, Charles
League Position: Oppose
Hot/Priority: Hot
Policy Committee (primary): Public Safety

AB 1400 (Kamlager-Dove D) Workers' compensation: firefighting operations: civilian employees.

Status: 5/6/2019-Read second time. Ordered to third reading.

Desk	Policy	Fiscal	Floor	Desk	Policy	Fiscal	Floor	Conf. Conc.	Enrolled	Vetoed	Chaptered
1st House				2nd House							

Summary:

Current law provides that in the case of active firefighting members of certain fire departments, a compensable injury includes cancer that develops or manifests while the firefighter member is in the

service of the public agency and exposed to a known carcinogen, as defined. Current law establishes a presumption that the cancer in these cases arose out of, and in the course of, employment, unless the presumption is controverted by evidence that the primary site of the cancer has been established and that the carcinogen to which the member has demonstrated exposure is not reasonably linked to the disabling cancer. This bill would enact a similar law that would be applicable to other employees of a city, county, city and county, district, or other municipal corporation or political subdivision whose job duties cause them to be regularly exposed to active fires or health hazards directly resulting from firefighting operations.

Primary Lobbyist: Hutchings, Dane
League Position: Oppose
Hot/Priority: Hot
Policy Committee (primary): Governance, Transparency, and Labor Relations

AB 1763 (Chiu D) Planning and zoning: density bonuses: affordable housing.

Status: 5/2/2019-Read second time. Ordered to Consent Calendar.

Desk	Policy	Fiscal	Floor	Desk	Policy	Fiscal	Floor	Conf. Conc.	Enrolled	Vetoed	Chaptered
1st House				2nd House							

Summary:

Would require a density bonus to be provided to a developer who agrees to construct a housing development in which 100% of the total units, exclusive of managers' units, are for lower income households, as defined. The bill would also require that a housing development that meets this criteria receive 4 incentives or concessions under the Density Bonus Law.

Primary Lobbyist: Rhine, Jason
League Position: Oppose Unless Amend
Hot/Priority: Hot
Policy Committee (primary): Housing Community and Economic Development

ACA 1 (Aguiar-Curry D) Local government financing: affordable housing and public infrastructure: voter approval.

Status: 4/24/2019-In committee: Set, first hearing. Referred to APPR. suspense file.

Desk	Policy	Fiscal	Floor	Desk	Policy	Fiscal	Floor	Conf. Conc.	Enrolled	Vetoed	Chaptered
1st House				2nd House							

Summary:

The California Constitution prohibits the ad valorem tax rate on real property from exceeding 1% of the full cash value of the property, subject to certain exceptions. This measure would create an additional exception to the 1% limit that would authorize a city, county, city and county, or special district to levy an ad valorem tax to service bonded indebtedness incurred to fund the construction, reconstruction, rehabilitation, or replacement of public infrastructure, affordable housing, or permanent supportive housing, or the acquisition or lease of real property for those purposes, if the proposition proposing that tax is approved by 55% of the voters of the city, county, or city and county, as applicable, and the proposition includes specified accountability requirements.

Primary Lobbyist: Carrigg, Dan
League Position: Support
Hot/Priority: Hot
Policy Committee (primary): Revenue and Taxation, Transportation, Communications and Public Works

SB 5 (Beall D) Affordable Housing and Community Development Investment Program.

Status: 4/29/2019-April 29 hearing: Placed on APPR. suspense file.

Desk	Policy	Fiscal	Floor	Desk	Policy	Fiscal	Floor	Conf. Conc.	Enrolled	Vetoed	Chaptered
1st House				2nd House							

Summary:

Would establish in state government the Affordable Housing and Community Development Investment Program, which would be administered by the Affordable Housing and Community Development Investment Committee. The bill would authorize a city, county, city and county, joint powers agency, enhanced infrastructure financing district, affordable housing authority, community revitalization and investment authority, transit village development district, or a combination of those entities, to apply to the Affordable Housing and Community Development Investment Committee to participate in the program and would authorize the committee to approve or deny plans for projects meeting specific criteria.

Primary Lobbyist: Rhine, Jason
League Position: Support
Hot/Priority: Hot
Policy Committee (primary): Housing Community and Economic Development, Revenue and Taxation

SB 13 (Wieckowski D) Accessory dwelling units.

Status: 5/6/2019-May 6 hearing: Placed on APPR. suspense file.

Desk	Policy	Fiscal	Floor	Desk	Policy	Fiscal	Floor	Conf. Conc.	Enrolled	Vetoed	Chaptered
1st House				2nd House							

Summary:

Would authorize the creation of accessory dwelling units in areas zoned to allow single-family or multifamily dwelling use. The bill would also revise the requirements for an accessory dwelling unit by providing that the accessory dwelling unit may be attached to, or located within, an attached garage, storage area, or other structure, and that it does not exceed a specified amount of total floor area.

Primary Lobbyist: Rhine, Jason
League Position: Oppose Unless Amend
Hot/Priority: Hot
Policy Committee (primary): Housing Community and Economic Development

SB 50 (Wiener D) Planning and zoning: housing development: incentives.

Status: 5/3/2019-Set for hearing May 13.

Desk	Policy	Fiscal	Floor	Desk	Policy	Fiscal	Floor	Conf. Conc.	Enrolled	Vetoed	Chaptered
1st House				2nd House							

Summary:

Would authorize a development proponent of a neighborhood multifamily project located on an eligible parcel to submit an application for a streamlined, ministerial approval process that is not subject to a conditional use permit. The bill would define a "neighborhood multifamily project" to mean a project to construct a multifamily structure on vacant land, or to convert an existing structure that does not require substantial exterior alteration into a multifamily structure, consisting of up to 4 residential dwelling units and that meets local height, setback, and lot coverage zoning requirements as they existed on July 1, 2019.

Primary Lobbyist: Rhine, Jason
League Position: Oppose Unless Amend
Hot/Priority: Hot
Policy Committee (primary): Housing Community and Economic Development

SB 230 (Caballero D) Law enforcement: use of deadly force: training: policies.

Status: 5/3/2019-Set for hearing May 13.

Desk	Policy	Fiscal	Floor	Desk	Policy	Fiscal	Floor	Conf. Conc.	Enrolled	Vetoed	Chaptered
1st House				2nd House							

Summary:

Would require each law enforcement agency to maintain a policy that provides guidelines on the use of force, utilizing deescalation techniques and other alternatives to force when feasible, specific guidelines for the application of deadly force, and factors for evaluating and reviewing all use of force incidents, among other things. The bill would require each agency to make their use of force policy accessible to the public. By imposing additional duties on local agencies, this bill would create a state-mandated local program.

Primary Lobbyist: Harvey, Charles
League Position: Support
Hot/Priority: Hot
Policy Committee (primary): Public Safety

SB 330 (Skinner D) Housing Crisis Act of 2019.

Status: 5/7/2019-From committee with author's amendments. Read second time and amended. Re-referred to Com. on APPR.

Desk	Policy	Fiscal	Floor	Desk	Policy	Fiscal	Floor	Conf. Conc.	Enrolled	Vetoed	Chaptered
1st House				2nd House							

Summary:

The The Housing Accountability Act requires a local agency that proposes to disapprove a housing development project that complies with applicable, objective general plan and zoning standards and

criteria that were in effect at the time the application was deemed to be complete, or to approve it on the condition that it be developed at a lower density, to base its decision upon written findings supported by substantial evidence on the record that specified conditions exist, and places the burden of proof on the local agency to that effect. The act requires a court to impose a fine on a local agency under certain circumstances and requires that the fine be at least \$10,000 per housing unit in the housing development project on the date the application was deemed complete. This bill would, until January 1, 2030, specify that an application is deemed complete for these purposes if a preliminary application was submitted, as specified.

Primary Lobbyist: Rhine, Jason
League Position: Oppose
Hot/Priority: Hot
Policy Committee (primary): Housing Community and Economic Development

SB 542 (Stern D) Workers' compensation.

Status: 4/22/2019-April 22 hearing: Placed on APPR. suspense file.

Desk	Policy	Fiscal	Floor	Desk	Policy	Fiscal	Floor	Conf. Conc.	Enrolled	Vetoed	Chaptered
1st House				2nd House							

Summary:

Would provide that in the case of certain state and local firefighting personnel and peace officers, the term "injury" also includes a mental health condition or mental disability that results in a diagnosis of post-traumatic stress or mental health disorder that develops or manifests itself during a period in which the firefighting member or peace officer is in the service of the department or unit. These provisions would apply to claims for benefits filed or pending on or after January 1, 2017.

Primary Lobbyist: Hutchings, Dane
League Position: Oppose
Hot/Priority: Hot
Policy Committee (primary): Governance, Transparency, and Labor Relations

SB 669 (Caballero D) Water quality: Safe Drinking Water Fund.

Status: 5/3/2019-Set for hearing May 13.

Desk	Policy	Fiscal	Floor	Desk	Policy	Fiscal	Floor	Conf. Conc.	Enrolled	Vetoed	Chaptered
1st House				2nd House							

Summary:

Would establish the Safe Drinking Water Fund in the State Treasury and would provide that moneys in the fund are continuously appropriated to the State Water Resources Control Board. The bill would require the state board to administer the fund to assist community water systems in disadvantaged communities that are chronically noncompliant relative to the federal and state drinking water standards and do not have the financial capacity to pay for operation and maintenance costs to comply with those standards, as specified.

Primary Lobbyist: Dolfie, Derek
League Position: Support
Hot/Priority: Hot
Policy Committee (primary): Environmental Quality

SB 670 (McGuire D) Telecommunications: outages affecting public safety.

Status: 5/6/2019-May 6 hearing: Placed on APPR. suspense file.

Desk	Policy	Fiscal	Floor	Desk	Policy	Fiscal	Floor	Conf. Conc.	Enrolled	Vetoed	Chaptered
1st House				2nd House							

Summary:

Would require a provider of telecommunications services, as defined, that provides access to 911 service to provide responder outage notification by electronic mail to the Office of Emergency Services whenever an outage occurs limiting the provider's customers' ability to make 911 calls or receive emergency notifications, within 60 minutes of discovering the outage. The bill would make the Office of Emergency Services responsible for notifying any applicable county office of emergency services and the sheriff of any county affected by the outage. The bill would require the responder outage notification to the Office of Emergency Services to include the telecommunications provider's contact name, a calling number to be staffed as specified, and a description of the estimated area affected by the outage.

Primary Lobbyist: Berdugo, Rony

League Position: Support

Hot/Priority: Hot

Policy Committee (primary): Transportation, Communications and Public Works

Total Measures: 21

Total Tracking Forms: 21

Thursday, May 16, 2019

[SB 332](#)

([Hertzberg D](#)) Wastewater treatment: recycled water. (Amended: 4/30/2019)

Status: 5/14/2019-Set for hearing May 16.

Location: 5/13/2019-S. APPR. SUSPENSE FILE

Desk	Policy	Fiscal	Floor	Desk	Policy	Fiscal	Floor	Conf. Conc.	Enrolled	Vetoed	Chaptered
1st House				2nd House							

Calendar: 5/16/2019 Upon adjournment of Session - John L. Burton Hearing Room (4203) SENATE APPROPRIATIONS SUSPENSE, PORTANTINO, Chair

Summary: The California Constitution requires that the water resources of the state be put to beneficial use to the fullest extent of which they are capable and that the waste or unreasonable use or unreasonable method of use of water be prevented. Existing law declares that the use of potable domestic water for certain nonpotable uses is a waste or an unreasonable use of water if recycled water is available, as determined by the State Water Resources Control Board, and other requirements are met. This bill would declare, except in compliance with the bill’s provisions, that the discharge of treated wastewater from ocean outfalls is a waste and unreasonable use of water. The bill would require each wastewater treatment facility that discharges through an ocean outfall and affiliated water suppliers to reduce the facility’s annual flow as compared to the average annual dry weather wastewater discharge baseline volume, as prescribed, by at least 50% on or before January 1, 2030, and by at least 95% on or before January 1, 2040. The bill would subject the owner or operator of a wastewater treatment facility, as well as the affiliated water suppliers, to a civil penalty of \$2,000 per acre-foot of water above the required reduction in overall volume discharge for the failure to meet these deadlines. This bill contains other related provisions and other existing laws.

Attachments:

- [SB 332 \(Hertzberg\) Coalition Oppose Sen Approps 5.6.19](#)
- [SB 332 \(Hertzberg\) CITY SAMPLE Oppose Sen Judiciary 4.10.19](#)
- [SB 332 \(Hertzberg\) Coalition Oppose Sen Judiciary 4.9.19](#)

Policy Committee (primary)	Primary Lobbyist	2nd Lobbyist
Environmental Quality	Dolfie, Derek	Berdugo, Rony
League Position	Hot/Priority	Policy Analyst
Oppose		Analyst I

NOTE – The Legislature has a new letter submission process that requires **ALL LETTERS TO BE UPLOADED INTO A NEW ELECTRONIC PORTAL**. The portal will automatically send letters to the author’s office and the committee(s) of jurisdiction. Please visit <https://calegislation.lc.ca.gov/advocates/> to create an account and upload this letter. If you are having difficulty accessing the portal, please contact Carly at our office cshelby@cacities.org 916-658-8279.

In addition to submitting the letter through the portal, please send a physical copy to your Legislator(s), and continue to send a copy by email to your Regional Public Affairs Manager, and the League’s city letter account (cityletters@cacities.org).

*****CITY LETTERHEAD *****

DATE

The Honorable Cecilia Aguiar-Curry
California State Assembly
State Capitol Building, Room 5144
Sacramento, CA 95814

RE: **ACA 1 (Aguiar-Curry). Local government financing: Affordable housing and public infrastructure: voter approval.**
Notice of SUPPORT

Dear Assembly Member Aguiar–Curry,

The City/Town of _____ is pleased to support your bill, ACA 1, which would lower the voter threshold requirements for special taxes by a local government for the purpose of providing funding for affordable housing and public infrastructure projects from 2/3rds approval to 55% approval.

As you know, local governments have widespread and urgent infrastructure needs and the high cost of housing in the state is well-documented. Local communities need additional flexibility to promote the development of affordable housing close to jobs and to continue to provide critical infrastructure for a better quality of life.

ACA 1 provides the voters an opportunity to consider treating investments in local infrastructure and affordable housing in a similar manner as schools. California voters have demonstrated through their past approval of major state school, housing, and water bonds, that they understand the importance of investing in their future.

Thank you for your leadership and let’s pass ACA 1 to provide voters with an opportunity to weigh in on local investments on infrastructure and affordable housing – issues that are so critical to the state’s future, prosperity and quality of life.

For these reasons, the City/Town of _____ supports ACA 1 (Aguiar-Curry).

Sincerely,

NAME

TITLE

CITY/TOWN of _____

cc: **Your Senator & Assembly Member**
Your League Regional Public Affairs Manager (via email)
Meg Desmond, League of California Cities, cityletters@cacities.org

NOTE – The Legislature has a new letter submission process that requires **ALL LETTERS TO BE UPLOADED INTO A NEW ELECTRONIC PORTAL**. The portal will automatically send letters to the author’s office and the committee(s) of jurisdiction. Please visit <https://calegislation.lc.ca.gov/advocates/> to create an account and upload this letter. If you are having difficulty accessing the portal, please contact Carly at our office cshelby@cacities.org 916-658-8279.

In addition to submitting the letter through the portal, please send a physical copy to your Legislator(s), and continue to send a copy by email to your Regional Public Affairs Manager, and the League’s city letter account (cityletters@cacities.org).

*****CITY LETTERHEAD*****

Date:

The Honorable Eloise Gómez Reyes
California State Assembly
State Capitol Building, Room 2175
Sacramento, CA 95814
VIA FAX: 916-319-2147

RE: AB 213 (Reyes) Annexation Finance: restoration of lost revenue.
Notice of Support

Dear Assembly Member Reyes:

The City/Town of _____ supports your AB 213 (Reyes) which would restore funding to cities that had annexed inhabited territory in reliance on previous financial incentives provided by AB 1602 (Laird) of 2006, then suffered significant fiscal harm when those funds were swept away approximately \$200 million annually from cities due to the passage SB 89 (2011) in response to the state’s then dire budget conditions. We also support restoring these incentives to improving service delivery via annexation to county residents —many who may be currently served by inadequate infrastructure and services.

The solution in the bill is consistent with the solution the Legislature approved in SB 130 of 2017 to restore funding to four recently incorporated cities harmed by SB 89. Moreover, addressing the losses of 140 annexing cities in this bill will cost less than \$5 million--one-quarter of the cost of SB 130.

USE one of the following Paragraphs (as Applicable)

If your city annexed inhabited territory and was entitled to receive additional per-capita revenue pursuant to AB 1602 (Laird) of 2006: (use League estimate from Attached Background sheet)

The City/Town of _____ lost approximately \$ _____ annually following the passage of SB 89, and AB 213 (Reyes) would help restore the revenue our city relied upon when making the policy decision to annex and serve new residents. *(If appropriate, insert additional information how the loss of revenue affected your city and the services it provides to its residents.)*

If your city is contemplating the annexation of inhabited territory in 2019 and beyond, and the restoration of fiscal incentives could assist such a decision “pencil-out” then use this paragraph:

The City/Town of _____ supports the restoration of fiscal incentives that support the policy of city annexation of adjacent inhabited territory. In many cases an annexation may be desired by affected residents and consistent with LAFCO policies, yet the financing does not work for the city to extend services to the new territory. This measure would help make some annexations fiscally viable and thereby consolidate and improve service delivery to affected residents. (Insert a local example if warranted)

For these reasons, the City/Town of _____ supports AB 213 (Reyes).

Sincerely,

NAME

TITLE

CITY/TOWN of _____

cc: Your Senator & Assembly Member
Your League Regional Public Affairs Manager (via email)
Meg Desmond, League of California Cities, cityletters@cacities.org

NOTE – The Legislature has a new letter submission process that requires **ALL LETTERS TO BE UPLOADED INTO A NEW ELECTRONIC PORTAL**. The portal will automatically send letters to the author’s office and the committee(s) of jurisdiction. Please visit <https://calegislation.lc.ca.gov/advocates/> to create an account and upload this letter. If you are having difficulty accessing the portal, please contact Carly at our office cshelby@cacities.org 916-658-8279.

In addition to submitting the letter through the portal, please send a physical copy to your Legislator(s), and continue to send a copy by email to your Regional Public Affairs Manager, and the League’s city letter account (cityletters@cacities.org).

*****CITY LETTERHEAD*****

DATE

The Honorable Aguiar-Curry
Chair, Assembly Local Government Committee
State Capitol Building, Room 5144
Sacramento, CA 95814

RE: **AB 849 (Bonta) Elections: local redistricting.**
Notice of Opposition

Dear Assembly Member Curry,

The City/Town of _____ must respectfully oppose AB 849, which would require every county, city, special district, school district, community college district, and county board of education to completely overhaul their entire process for establishing new election district boundaries and modifying existing ones.

AB 849 mandates that each local agency dependent on population size hold up to 10 public meetings, in different locations within their jurisdiction. Roughly half of these meetings must take place in the evenings and on the weekends which will result in overtime for employees required to staff the meetings. Considering there are 58 counties, 482 cities, 977 school districts and approximately 2,000 special districts, there is going to be more redistricting meetings than the public could possibly attend. For example, when taking into account the number of special districts and school boards within a large city or county, local agencies will potentially host hundreds of meetings simultaneously, competing with each other for locations and will likely have to expend significant taxpayer dollars in employee overtime, rental space and equipment.

(Insert specific information about how the requirements in this measure would impact your city.)

AB 849 would create unworkable confusion and implementation challenges for not only our city but thousands of local government agencies in California. This measure would remove virtually all local discretion on essentially every aspect of how an agency can establish, adopt and redrawn

electoral boundaries. This will result in hundreds of millions of dollars of mandates which will either be unfunded or suspended by the State.

In 2016, Senate Bill 1108 authorized all California cities and counties to create independent citizens' commissions to redraw district lines. However, rather than allow those independent commissions to be established and determine the number of public meetings they need to accomplish their goals and meet the needs of their communities. This bill strips local control and mandates how every type of local government must outreach to their own communities. This bill appears to be a solution in search of a problem.

For these reasons, the **City/Town of _____** opposes AB 849 (Bonta).

Sincerely,

NAME

TITLE

CITY/TOWN of _____

cc: The Honorable Rob Bonta,
Your Senator & Assembly Member
Your League Regional Public Affairs Manager (via email)
League of California Cities, cityletters@cacities.org

NOTE – The Legislature has a new letter submission process that requires **ALL LETTERS TO BE UPLOADED INTO A NEW ELECTRONIC PORTAL**. The portal will automatically send letters to the author’s office and the committee(s) of jurisdiction. Please visit <https://calegislation.lc.ca.gov/advocates/> to create an account and upload this letter. If you are having difficulty accessing the portal, please contact Carly at our office cshelby@cacities.org 916-658-8279.

In addition to submitting the letter through the portal, please send a physical copy to your Legislator(s), and continue to send a copy by email to your Regional Public Affairs Manager, and the League’s city letter account (cityletters@cacities.org).

*****CITY LETTERHEAD*****

DATE

The Honorable Rob Bonta
California State Assembly
State Capitol Building, Room 2148
Sacramento, CA 95814

RE: **AB 1332 (Bonta) Sanctuary State Contracting and Investment Act.**
Notice of Opposition

Dear Assembly Member Bonta,

The City/Town of _____ must respectfully oppose your AB 1332, which would significantly limit or effectively eliminate the ability for state and local agencies to cost-effectively contract for a variety of public services, create an ever-evolving blacklist of prohibited companies and create millions of dollars of unfunded mandates.

The primary purpose of public agency procurement is to provide vital services to the public. AB 1332 would cripple that primary purpose by vastly escalating the time and cost to contract, inviting litigation, and creating insurmountable operational and financial challenges.

For the City/Town of _____ this measure would harm our ability to meet financial regulations, curb our ability to audit, and respond to, and administer programs. It would also significantly increase costs and staff workload while hindering our ability to collect revenue.

(If warranted, provide a specific example of how this measure would impact your city.)

While this bill may have a laudable goal, it does so at the expense of California’s state and local agencies as well as law enforcement and first respondent agencies that depend on the most current and readily available technology to ensure the public’s safety. All told the provisions set forth in this proposal are unworkable and the broad scope and vague definitions in this measure will have unintended consequences and impacts.

- Impede a city’s ability to do legal research and defend against litigation;
- Harm a city’s ability to meet financial regulations;
- Curb a city’s ability to audit, respond to, and administer programs; and
- And significantly increase costs and staff workload while hindering a city’s ability to collect revenue.

For these reasons, the City/Town of _____ opposes AB 1332 (Bonta).

Sincerely,

NAME

TITLE

CITY/TOWN of _____

cc: Chair and Members, Assembly Judiciary Committee
Your Senator & Assembly Member
Your League Regional Public Affairs Manager (via email)
League of California Cities, cityletters@cacities.org

*****CITY LETTERHEAD*****

Date:

The Honorable Lorena Gonzalez
Chair, Assembly Committee on Appropriations
State Capitol Building, Room 5050
Sacramento, CA 95814

**RE: AB 1356 (Ting) Cannabis: Local Jurisdiction: Retail Commercial Cannabis Activity
Notice of OPPOSITION (as Amended 4/30/19)**

Dear Assemblymember Gonzalez:

The City/Town of _____ respectfully opposes AB 1356 (Ting). Under this bill, if more than 50 percent of the voters of a local jurisdiction voted in favor of Proposition 64, these local jurisdictions would be required to issue a minimum number of licenses authorizing retail cannabis activity within that jurisdiction. More specifically, the bill requires these cities to issue a minimum of one retail cannabis license for every four liquor licenses, or one retail cannabis license for every 10,000 residents.

Existing law, under both the Medicinal and Adult-Use Cannabis Regulation and Safety Act (MAUCRSA) and Proposition 64, states that local jurisdictions have the ability to adopt and enforce local ordinances to regulate cannabis businesses. By removing local governments' ability to regulate brick and mortar retail cannabis shops, AB 1356 undermines the very foundation of local control and thereby negates the primary purpose of California's established dual licensing structure.

PLEASE CITE SPECIFIC CONCERNS AND HOW YOUR CITY WILL BE EFFECTED BY THIS BILL HERE.

With regard to the measure's mandated 1-to-4 ratio, there is simply no nexus between a city's regulation of citizens' access to retail commercial cannabis and the number of liquor establishments within a community. By requiring such a ratio, AB 1356 proposes an arbitrary land use standard for individual cities and counties based on the results of a statewide ballot measure.

In seeking to eliminate locals' authority to ban or regulate retail commercial cannabis businesses, AB 1356 would ultimately strip cities and counties of the ability to decide what is appropriate for their communities—a premise that directly contravenes the framework understood by the voters when approving Proposition 64.

For these reasons, the City/Town of _____ opposes AB 1356.

Sincerely,

NAME

TITLE

CITY/TOWN of _____

cc. **Your Senator & Assembly Member**
Your League Regional Public Affairs Manager (via email)
League of California Cities via email at: cityletters@cacities.org

NOTE – The Legislature has a new letter submission process that requires **ALL LETTERS TO BE UPLOADED INTO A NEW ELECTRONIC PORTAL**. The portal will automatically send letters to the author’s office and the committee(s) of jurisdiction. Please visit <https://calegislation.lc.ca.gov/advocates/> to create an account and upload this letter. If you are having difficulty accessing the portal, please contact Carly at our office cshelby@cacities.org 916-658-8279.

In addition to submitting the letter through the portal, please send a physical copy to your Legislator(s), and continue to send a copy by email to your Regional Public Affairs Manager, and the League’s city letter account (cityletters@cacities.org).

*****CITY LETTERHEAD*****

Date:

The Honorable Jim Beall
California State Senate
State Capitol Building, Room 2082
Sacramento, CA 95814

The Honorable Mike McGuire
California State Senate
State Capitol Building, Room 5061
Sacramento, CA 95814

**Re: SB 5 (Beall/McGuire) Local-State Sustainable Investment Incentive Program
Notice of SUPPORT (As Introduced 12/03/2018)**

Dear Senator Beall and Senator McGuire:

The City/Town of _____ supports your SB 5 (Beall/McGuire), the Local-State Sustainable Investment Incentive Program.

The elimination of redevelopment in 2011 created a huge deficit in community revitalization resources throughout California, including an annual loss of \$1 billion in funding for low- and moderate-income housing.

SB 5 provides the opportunities for communities to access additional tax increment revenues to fund affordable housing, infrastructure, and economic development projects that advance state and local priorities, including reducing greenhouse gas emissions, expanding transit oriented development (TOD), addressing poverty, and revitalizing neighborhoods.

The City/Town of _____ commends you for recognizing the diversity of California cities and acknowledging the need for flexible funding to spur housing construction and revitalize communities.

If warranted, discuss:

- *How losing redevelopment has impacted your city.*
- *How your city would specifically benefit from a renewed state investment.*

The time is right for the state to fill the void left by the elimination of redevelopment and provide more tools to support local efforts to build more affordable housing, provide essential infrastructure, and create opportunities in underserved communities. The City/Town of _____ applauds your leadership in this effort to give cities the tools they need to improve their communities.

For these reasons, the City/Town of _____ supports SB 5 (Beall/McGuire).

Sincerely,

NAME

TITLE

CITY/TOWN of

cc: Your Senator & Assembly Member
Your League Regional Public Affairs Manager (via email)
Meg Desmond, League of California Cities, cityletters@cacities.org

NOTE – The Legislature has a new letter submission process that requires **ALL LETTERS TO BE UPLOADED INTO A NEW ELECTRONIC PORTAL**. The portal will automatically send letters to the author’s office and the committee(s) of jurisdiction. Please visit <https://calegislation.lc.ca.gov/advocates/> to create an account and upload this letter. If you are having difficulty accessing the portal, please contact Carly at our office cshelby@cacities.org 916-658-8279.

In addition to submitting the letter through the portal, please send a physical copy to your Legislator(s), and continue to send a copy by email to your Regional Public Affairs Manager, and the League’s city letter account (cityletters@cacities.org).

*****CITY LETTERHEAD*****

DATE

The Honorable Scott Wiener
Chair, Senate Housing Committee
California State Capitol, Room 5100
Sacramento, CA 95814

RE: SB 330 (Skinner) Housing Crisis Act of 2019.
Notice of Opposition (As Amended 4/4/19)

Dear Senator Wiener:

The **City/Town of _____** must respectfully oppose SB 330. This measure would, among other things, declare a statewide housing crisis and for a ten-year period, prohibit a city from imposing parking requirements, adjusting impact fees, imposing impact fees on affordable housing projects, and limiting new design standards based on cost.

We agree with the fundamental problem—there aren’t enough homes being built in California. Unfortunately, SB 330 as presently drafted lacks the flexibility needed to meet the State’s housing goals while also acknowledging community input and engagement.

Specifically, the **City/Town of _____** has significant concerns with the following:

- **No parking requirements** – Regardless of the size of the housing project, proximity or availability of high quality public transit, SB 330 would strictly prohibit our city from imposing any type of parking standard. Without parking requirements, developers will force new residents to compete for an ever-diminishing supply of parking. This will certainly lead to significant congestion and parking conflicts in many communities because people strongly resist giving up their vehicle, especially if public transit is inadequate.
- **Freeze impact fees** – This measure would lock in place nearly all fees or exactions imposed on development projects. These fees are imposed in order to provide the public improvements and public services necessary to meet the needs of the new residents. Cities can only charge a fee to

cover the cost of delivering the service. Freezing fees for a decade will make it very difficult for us to serve our community.

- **No impact fees for affordable housing** – While it may seem reasonable to prohibit cities from imposing impact fees on affordable housing projects, the reality is that without these fees, many cities will struggle to provide the needed services. In order to provide those services, cities would have to subsidize the project out of general fund revenues if they are available. Additionally, cities do not receive property tax from affordable housing projects that fall under the Welfare Exemption, thus further restricting funds available to provide essential services.
- **No new design standards if they are more costly** – SB 330 would prohibit us from imposing any new design standard that is more costly than those in effect on January 1, 2018. This would effectively prohibit any new design standards for a ten-year period because the cost of material and labor continue to increase.

If applicable, please cite how your city will be affected by the bill.

The City/Town of _____ strongly questions the effectiveness of limiting parking, restricting fees, and limiting design standard costs and what this means for housing production or cost. SB 330 does not require any of the cost savings associated with these limitations to be passed on to the consumer. Developers would most likely pocket the savings and enhance their profits.

For these reasons, the City/Town of _____ opposes SB 330.

Sincerely,

NAME

TITLE

CITY/TOWN of _____

cc. The Honorable Nancy Skinner
Your Senator & Assembly Member
Your League Regional Public Affairs Manager (via email)
League of California Cities, cityletters@cacities.org

Note: In lieu of submitting this letter electronically through the portal, please email a copy of this letter to sjud.fax@sen.ca.gov along with cc'ing your legislator, your regional public affairs manager, and the League's city letter email.

*****CITY LETTERHEAD*****

Date

The Honorable Hannah-Beth Jackson, Chair
Senate Judiciary Committee
State Capitol, Room 2187
Sacramento, CA 95814

RE: SB 332 (Hertzberg) Wastewater treatment: recycled water.
Notice of Opposition (As Introduced 2/19/9)

Dear Senator Jackson:

The City/Town of _____ respectfully **Opposes** SB 332 (Hertzberg). As introduced, this measure would mandate wastewater treatment agencies that discharge treated effluent to saline waters, oceans, bays and estuaries to reduce their discharges by 50% of baseline volume by January 1, 2030, and by 95% of baseline volume by January 1, 2040. The bill would also declare that discharge from ocean outfalls is a "waste and unreasonable use" of water and impose penalties of \$2,000/acre-foot of water discharged above the reduction requirement.

California has a significant number of wastewater ocean and bay dischargers, and they vary dramatically in terms of treatment capacity, discharge, and the amount of recycling that occurs. Each watershed, region, treatment facility, and outfall is different, and the capability to beneficially reuse wastewater varies widely as well. Reliable and feasible end uses for recycled water are not always available and depend on factors other than simply the discharger's technical ability to supply recycled water.

[If applicable, please have your Public Works Director or water infrastructure staff comment on regional use and demand for recycled water availability. Also discuss how this bill will pose challenges for your city.] For these reasons, a mandate on every ocean and bay discharger in the state is simply unworkable. In many circumstances, regional demand may not exist to reuse 95 percent of an agency's ocean discharge.

In addition, recharge and reuse options may be unavailable or infeasible for a variety of reasons, such as geographical or legal constraints in the watershed. Furthermore, distribution can require complex arrangements between water recyclers and water purveyors, brine management may present significant issues in some areas, and public acceptance of beneficial reuse of wastewater remains an obstacle. These challenges exist and require a regional approach to the management of recycled water supplies.

As of today, the regulatory framework necessary for agencies to plan and implement projects to manage the massive volumes of water contemplated in SB 332 does not exist. Existing beneficial reuse options are limited and could not be utilized to manage such a vast quantity of water. Instead, every agency would necessarily need to implement large scale potable reuse projects. The State Water Board is

charged with developing regulations for Direct Potable Reuse by 2023. Until that regulatory scheme has been developed it will be nearly impossible for agencies to plan for, let alone implement, projects to meet the mandate deadlines in SB 332. If the regulations are completed on schedule, agencies would then have a seven year window to plan, approve, execute and operate new infrastructure that would dramatically shift their day to day operations. To put this in perspective, some of the most ambitious recycling projects underway in the state currently have 20 to 30 year project schedules, and when fully operational will still not meet the discharge mandate proposed in the bill. Furthermore, no consideration is being given to these ambitious projects in the development of baseline discharge metrics, nor to other innovative project components such as stormwater capture and treatment.

California is already aggressively pursuing maximized water recycling as a regulatory priority. The State Water Board recently adopted revisions to its Recycled Water Policy that, for the first time, require wastewater treatment plants and recycled water producers to report the volume of wastewater treated and discharged, specify the level of treatment, and identify the volume of recycled water produced. The policy also requires annual reporting of monthly volume of treated wastewater discharged to the environment, which will be used to estimate the amount of wastewater that may be available to recycle. There are numerous technical realities in the wastewater treatment and management processes that have not been considered in SB 332. The bill lacks consideration of major operational issues surrounding brine management, wet weather influent management, existing regulatory constraints relative to minimum flows, and other real and substantive conflicts with how wastewater agencies function in their communities. These technical issues are vast, far reaching, and vary based on the regional watershed and individual permitting levels.

It is important to note that some of California's most ambitious policy goals are not accounted for in SB 332, and we believe the implementation of the proposed mandate would have far reaching impacts that are contrary to those goals. For example, California is a leader on climate change mitigation and adaptation and has taken several steps in recent years to curb emissions and transition to a more sustainable future. SB 332 could adversely impact those efforts by increasing the emissions associated with advanced wastewater treatment and the associated energy demand required to move the high volumes of water over or across a variety of geographical settings.

California is simultaneously pursuing policies to make living more affordable for all residents of the state. Unfortunately, SB 332 makes no consideration of the impacts that the massive proposed infrastructure would have on rate increases in the immediate future for a significant portion of the state's population, including some of the most disadvantaged communities in California. The proposed mandate would require rate increases in the order of hundreds of dollars per month per household in the impacted communities. The rate implications would likely have a trickle-down effect of impacting housing affordability as well, as connection fees and ongoing rates would necessarily increase living expenses and the cost of new development in impacted areas.

[If applicable, include technical examples of how SB 332 will be impossible or extremely difficult for your city to comply with.]

Unfortunately, SB 332 does not provide a workable pathway toward achieving the goal of maximizing recycled water to the fullest extent feasible in California.

For these reasons, the City/Town of _____ must **Oppose** SB 332. Thank you for your consideration of our position.

Sincerely,

NAME

TITLE

CITY/TOWN of _____

cc: The Honorable Bob Hertzberg
Your Senator & Assembly Member
Your League Regional Public Affairs Manager (via email)
League of California Cities (via email: cityletters@cacities.org)

Staff Report

TO: Mayor and City Council Members

FROM: Sean Thuilliez, Chief of Police

DATE: May 21, 2019

SUBJECT: Response to Sidewalk Vending

Background and Analysis:

There are several rationales relied upon by opponents of legalized vending to support the continued criminal prosecution of sidewalk vendors. These publicly-stated rationales include reducing crime, preventing business competition, and enhancing public safety. Indeed, many municipal codes throughout the country that criminalize sidewalk vending relies on these very rationales: sidewalk vending should be criminally prosecuted in order to protect against “visual clutter,” “blight,” and “public health and safety.”

However, these rationales are not supported by empirical evidence and by in large targets a population that is almost exclusively people of color¹. A class of people who are subjected to constant policing, stops and seizures, mounting criminal justice debt, and even arrest and incarceration.

Crime reduction is often cited as a rationale for prosecuting sidewalk vending. Vigorous enforcement of order maintenance laws like sidewalk vending is most closely associated with the “broken windows” theory of policing. The notion, taken from George Kelling and James Wilson’s *Atlantic Monthly* essay² on the topic, is that if one window is left broken and unrepaired, soon all the building’s windows will be broken. Such theories of policing have been influential in law enforcement.

Yet, these theories of policing vendors remain unproven. In other contexts, experts have learned that broken windows policing does not necessarily reduce crime rates. For example, a comprehensive study³ of such policing strategies in New York City concluded that there was no statistically significant relationship between public disorder enforcement

¹ Sarmiento, Hugo. **The Spatial Politics of Street Vending in Los Angeles**. UCLA Institute for Research on Labor and Employment Research & Policy Brief #19. 2015 Feb.

² Kelling, George L.; Wilson, James Q. **Broken windows: the police and neighborhood safety**. *Atlantic Monthly*. 1982 Mar; 249(3):29–38.

³ Peters, Mark G.; Eure, Philip K. **An analysis of quality of life summonses, quality of life misdemeanor arrests and felony crime in New York City**, 2010-2015. New York City Department of Investigation Office of the Inspector General for the NYPD (OIC-NYPD). 2016.

and the commission of more serious crimes such as assault, burglary, and rape. In Los Angeles, a recent spatial analysis of vending and crime found that the presence of sidewalk vendors was not statistically correlated with violent crime incidents.

California Senate Bill 946 (Lara) attempts to reverse the misguided practice of criminalizing sidewalk vendors by prohibiting a local authority from unethically regulating sidewalk vendors. The Bill took effect January 1, 2019, and defined vendors as follows:

Sidewalk vendor - means a person who sells food or merchandise from a pushcart, stand, display, pedal-driven cart, wagon, showcase, rack, or other nonmotorized conveyance, or from one's person, upon a public sidewalk or other pedestrian path.

Roaming sidewalk vendor - means a sidewalk vendor who moves from place to place and stops only to complete a transaction.

Stationary sidewalk vendor - means a sidewalk vendor who vends from a fixed location.

In summary; the Bill allows sidewalk vendors to operate on any public right-of-way, including sidewalks, publicly owned parks and parking lots, unless such operations causes health, safety, or welfare concerns. Allows the local jurisdiction to require vendors to obtain a permit for sidewalk vending. And, protects sidewalk vendors from criminal prosecution for violations of local ordinances related to sidewalk vending. The legislature's intent by design was to offer limited enforcement options.

Since January 1, 2019, the Beaumont Police Department has responded to the following Calls For Service (CFS) related to sidewalk vending:

January	11 CFS
February	5 CFS
March	3 CFS
April	7 CFS

Excluding one instance, responding officers contacted the sidewalk vendors and inquired about their City of Beaumont Business License Permit (Beaumont Municipal Code 5.04.010 – Permit Requirements). Those that were in compliance were allowed to vend unobstructed. Those that did not possess a permit, were afforded a warning and directed to cease their activities. Officers encountered several challenges, unrelated to the act of vending, during the calls for service. Language barriers and vendor transportation issues were recurring themes.

The most concerning safety hazard was the vendors utilizing the southwest corner of Pennsylvania and First Street to sell merchandise. This caused potential customers to stop in a bike lane on First Street which backed eastbound traffic up. The vendors have moved to the Northeast corner which has a large dirt roadway edge for vehicles that do not block or impede traffic.

Seizing sidewalk vendor's property without probable cause, and without a warrant, raises serious Fourth Amendment concerns. Intentional or unintentional violations of Constitutional protections exposes the department, the City, and the officer to unnecessary liability⁴. In response to this, the department has developed an in-service training program to educate officers and City staff about the Bill, and enforcement expectations.

Looking to the future, the department created a VENDOR call-type in our Computer Aided Dispatch (CAD) system so that we can accurately track our CFS and responses to the sidewalk vending issue.

Sidewalk vending is not an activity that was created overnight, and its origins predate modern times. Our response to the legislature's intent to promote entrepreneurship and support immigrant and low-income communities will not bear fruit overnight, but rest assured it will be congruent with the legislative findings, considerate of applicable federal and state laws, and above all else ethical in its application.

Fiscal Impact:

No fiscal impact.

Finance Director Review: 

Recommendation:

Receive and file.

City Manager Review: 

Attachments:

A. Media article

⁴ 42 U.S. Code § 1983. Civil action for deprivation of rights

L.A. to spend up to \$150,000 to settle street vendor lawsuit

By EMILY ALPERT REYES
DEC 07, 2017 | 1:20 PM

Los Angeles lawmakers have agreed to spend up to \$150,000 to settle a lawsuit brought by street vendors who claimed that their carts and other belongings had been improperly seized and destroyed.

Pushcart vendors and their advocates sued the city two years ago, arguing that the Los Angeles Police Department and the Fashion District Business Improvement District, which contracts with cleanup crews, had trampled on their rights by taking away and trashing their belongings.

L.A. lawmakers have repeatedly vowed to legalize and regulate vending but selling food or goods on the sidewalk is still a violation of the municipal code, punishable with administrative fines.

Up until earlier this year, it also sometimes led to criminal charges. However, attorneys with the National Lawyers Guild and the ACLU of Southern California claimed that vendors were being stripped of their belongings even if they were not being arrested, “a sort of extrajudicial street punishment.”

The Los Angeles City Council voted 11 to 1 on Tuesday to approve spending up to \$150,000 to settle the suit, with Councilman Mitch Englander casting the lone vote against the plan. Englander declined to explain why he opposed the decision.

Cynthia Anderson-Barker, one of the attorneys representing the vendors, said the case “restores some dignity to a group that has been mistreated by law enforcement.”

“Law enforcement now recognizes that street vendors have legal rights to their property,” she said in a written statement.

The LAPD referred a request for comment to the city attorney, whose spokesman Rob Wilcox said that although the council had agreed how much it would offer, the settlement “was not finalized yet.”

Fashion District Business Improvement District Executive Director Rena Leddy said that once the deal was completed, the business improvement district would be dismissed from the case and would not have to pay attorney fees to the plaintiffs.

“We are pleased to have been dismissed from the case,” Leddy said in an email.

Staff Report

TO: Mayor and Council Members
 FROM: Jeff Hart, Public Works Director
 DATE: May 21, 2019
 SUBJECT: Receive and File the Oak Valley Traffic Signalization Project Summary Update

Oak Valley Traffic Signalization Project Update:

The Oak Valley Traffic Signalization project is near 80% complete. Below is a list of construction items remaining to be completed with tentative dates:

- Inspection for Edison work (Week of May 30, 2019).
- Edison will pull wire and energize system (Week of July 1, 2019).
- Additional curbing around Edison transformer for protection requested by inspector which was not on approved plan (May 15, 2019).
- Install sidewalk (Week of May 20, 2019).
- Install curb ramps (Week of May 27, 2019).
- Install metal beam guardrails (Week of June 3, 2019).
- Install asphalt (Week of June 17, 2019).
- Re-stripe road (Week of June 24, 2019).
- Install loop detectors (Week of July 1, 2019).
- Inspection with Caltrans and program signal gear (Week of July 9, 2019).

Before Caltrans will schedule a date to program the equipment and power the signals, the project must be in its permanent configuration and all equipment must be installed. City staff is anticipating a completion date by July 2019.

The following table is an overview of project funding available for the project:

Funding Source	Funding Amount
Road & Bridge DIF	\$ 360,000.00
Signal DIF	\$ 810,500.00
Grant Funding	\$ 290,000.00

The following is a revised comprehensive breakdown in project costs:

Potrero	Budget Amount	Actual	Remaining
Design	\$141,378.25	\$141,378.25	\$0.00
Project Management	\$10,828.88	\$10,828.88	\$0.00
Construction	\$1,194,042.99	\$652,873.73	\$541,169.26
Contingency	\$100,000.00	\$74,405.51	\$25,594.49
Total	\$1,446,250.12	\$879,486.37	\$566,763.75

The contract change orders to date are summarized below:

CCO No.	Description	Reason for Change	Total
1	Survey	To provide additional survey needed for the project roadway design	\$ 6,982.00
2	Temporary Lighting	To provide temporary street lighting	\$ 13,855.61
3	Catch Basin Mod.	Perform catch basin modifications to accommodate field conditions	\$ 1,575.00
4	Additional base, Metal Beam Guardrail, Light Fixtures, Caltrans rider permit, Credit	To provide additional base needed for the road widening, removal and reinstallation of MBGR to install new drainage, purchase of street light fixtures, and a credit back for bid item 13 & 14, deletion of bridge conduit, and deletion of two street lights.	\$ (9,194.32)
5	Additional asphalt, Edison materials & installation, transportation of poles & mast arms	To provide additional hot mix asphalt needed for the road widening, compensation for purchasing materials and installing to Edison specifications, and transporting of all signal poles and mast arms from City yard to job site.	\$ 49,577.98
6	Additional Edison Work	During a pre-construction meeting with Edison, the inspector had requested a special type of conduit and an additional sweep that wasn't shown on the plans, thus requiring additional labor and materials.	\$ 11,609.24
		Total	\$ 74,405.51

Fiscal Impact:

No fiscal impact.

Finance Director Review: 

Recommendation:

1. Receive and file the Oak Valley Traffic Signalization Project Summary Update.

City Manager Review: 

Staff Report

TO: Mayor and City Council Members

FROM: Todd Parton, City Manager

DATE: May 21, 2019

SUBJECT: Purchase of a 6.15-Acre Undeveloped Parcel of Land Generally Located at the Southwest Corner of Veile Avenue and Fourth Street – Assessor Parcel Number 417-110-018-3

Background and Analysis:

City staff has negotiated terms for the purchase of a vacant, 6.15-acre tract of land located at the southwest corner of Veile Avenue and Fourth Street. The tract is immediately adjacent to the eastern property line of the City's wastewater treatment plant.

Negotiated terms of the agreement provide for a purchase price of \$2,500,000 with closing to occur within 10 days of City Council approval. This purchase would be funded through two sources, \$1,500,000 through transit grant funds and \$1,000,000 through wastewater reserve funds.

A portion of the 6.15-acre tract will support the community's growing transit and public works needs. It will accommodate the relocation of decentralized Transit Department operations from the historic downtown to a full service, centralized transit operations campus. Transit operations to be relocated include the bus parking area, transit operations/administration building, and vehicle maintenance shop as well as the construction of a new compressed natural gas (CNG) fueling station. The relocation of the transit operations from downtown is vital to the City's revitalization plans.

Due to its adjacency to the Wastewater Treatment Plant (WWTP) the property is ideally suited to meet the needs of the City's growing public works operations. The property will provide for the construction of a WWTP service/storage yard as well as land to accommodate operational requirements of the Community Services and Street Maintenance Departments. This property has the added benefit of buffering the WWTP from adjacent development, thereby reducing significant capital expenses required for odor control. City staff estimates that \$3 million to \$5 million in capital costs will be avoided.

Fiscal Impact:

The City's State Transit Assistance capital grants will fund \$1,500,000 and wastewater reserve funds will fund \$1,000,000. No General Fund monies will be used in the purchase of this parcel.

Finance Director Review: _____

Recommendation:

This purchase accomplishes important policy objectives of the City and is a cost-effective strategy for meeting the growing service demands of the community. Accordingly, City staff recommends purchasing this property (Assessor Parcel Number 417-110-018-3, located at the southwest corner of Veile Avenue and Fourth Street) at the negotiated purchase price of \$2,500,000 and authorize the City manager to finalize the purchase agreement.

City Manager Review:  _____

Attachments:

- A. Purchase Agreement



CALIFORNIA
ASSOCIATION
OF REALTORS®

VACANT LAND PURCHASE AGREEMENT
AND JOINT ESCROW INSTRUCTIONS
(C.A.R. Form VLPA, Revised 4/10)

Date May 13, 2019

1. OFFER:

A. THIS IS AN OFFER FROM City of Beaumont, a municipal corp, its manager, Todd Parion, City Manager ("Buyer").
B. THE REAL PROPERTY TO BE ACQUIRED is described as Vacant Land APN: 417-110-018; SWC Fourth Street/Wale Avenue

Assessor's Parcel No(s) 417-110-018
situated in City of Beaumont, County of Riverside, California, ("Property").

C. THE PURCHASE PRICE offered is Two million, five hundred thousand (Dollars \$ \$2,500,000.00).
D. CLOSE OF ESCROW shall occur on 10 days after Council approval, no later than 10 (date) (or Days After Acceptance).

2. AGENCY:

A. POTENTIALLY COMPETING BUYERS AND SELLERS: Buyer and Seller each acknowledge receipt of a disclosure of the possibility of multiple representation by the Broker representing that principal. This disclosure may be part of a listing agreement, buyer representation agreement or separate document (C.A.R. Form DA). Buyer understands that Broker representing Buyer may also represent other potential buyers, who may consider, make offers on or ultimately acquire the Property. Seller understands that Broker representing Seller may also represent other sellers with competing properties of interest to this Buyer.

B. CONFIRMATION: The following agency relationships are hereby confirmed for this transaction:
Listing Agent None (Print Firm Name) is the agent of (check one): the Seller exclusively; or both the Buyer and Seller.
Selling Agent None (Print Firm Name) (if not the same as the Listing Agent) is the agent of (check one): the Buyer exclusively; or the Seller exclusively; or both the Buyer and Seller.
Real Estate Brokers are not parties to the Agreement between Buyer and Seller.

3. FINANCE TERMS: Buyer represents that funds will be good when deposited with Escrow Holder.

A. INITIAL DEPOSIT: Deposit shall be in the amount of \$ 150,000.00

(1) Buyer shall deliver deposit directly to Escrow Holder by personal check, electronic funds transfer, Other _____ within 3 business days after acceptance (or Other _____);

OR (2) (if checked) Buyer has given the deposit by personal check (or _____) to the agent submitting the offer (or to _____), made payable to _____, The deposit shall be held uncashed until Acceptance and then deposited with Escrow Holder (or into Broker's trust account) within 3 business days after Acceptance (or Other _____).

B. INCREASED DEPOSIT: Buyer shall deposit with Escrow Holder an increased deposit in the amount of \$ _____ within _____ Days After Acceptance, or _____.

C. LOAN(S)

(1) ~~FIRST LOAN~~ in the amount of \$ _____. This loan will be conventional financing or, if checked, FHA, VA, Seller (C.A.R. Form SFA), assumed financing (C.A.R. Form PAA), Other _____. This loan shall be at a fixed rate not to exceed _____% or, an adjustable rate loan with initial rate not to exceed _____%. Regardless of the type of loan, Buyer shall pay points not to exceed _____% of the loan amount.

(2) ~~SECOND LOAN~~ in the amount of \$ _____. This loan will be conventional financing or, if checked, Seller (C.A.R. Form SFA), assumed financing (C.A.R. Form PAA), Other _____. This loan shall be at a fixed rate not to exceed _____% or, an adjustable rate loan with initial rate not to exceed _____%. Regardless of the type of loan, Buyer shall pay points not to exceed _____% of the loan amount.

D. ADDITIONAL FINANCING TERMS:

ALL CASH OFFER: No loan is needed to purchase the Property. This offer is NOT contingent on Buyer obtaining a loan. Written verification of sufficient funds to close this transaction IS ATTACHED to this offer.

The following items are deleted: #3C, #3H, #3I, #3K, #3L, #3M. This agreement is expressly conditioned upon City Council approval.

E. BALANCE OF PURCHASE PRICE OR DOWN PAYMENT in the amount of \$ 2,350,000.00 to be deposited with Escrow Holder within sufficient time to close escrow.

F. PURCHASE PRICE (TOTAL): \$ 2,500,000.00

Buyer's Initials (TP) (_____)

Seller's Initials (JK) (_____)

The copyright laws of the United States (Title 17 U.S. Code) forbid the unauthorized reproduction of this form, or any portion thereof, by photocopy machine or any other means, including facsimile or computerized formats. Copyright © 1996-2010, CALIFORNIA ASSOCIATION OF REALTORS®, INC. ALL RIGHTS RESERVED.

Reviewed by _____ Date _____



VLPA REVISED 4/10 (PAGE 1 OF 10)

VACANT LAND PURCHASE AGREEMENT (VLPA PAGE 1 OF 10)

Agent: _____ Phone: _____ Fax: _____ Prepared using zipForm® software
Broker: _____

G. VERIFICATION OF DOWN PAYMENT AND CLOSING COSTS: Buyer (or Buyer's lender or loan broker pursuant to 3H(1)) shall, within 7 (or) Days After Acceptance, Deliver to Seller written verification of Buyer's down payment and closing costs. (If checked verification attached.)

H. LOAN TERMS:

(1) LOAN APPLICATIONS: Within 7 (or) Days After Acceptance, Buyer shall Deliver to Seller a letter from lender or loan broker stating that, based on a review of Buyer's written application and credit report, Buyer is prequalified or preapproved for any NEW loan specified in 3C above. (If checked letter attached.)

(2) NO LOAN CONTINGENCY: Buyer shall act diligently and in good faith to obtain the designated loan(s). Obtaining the loan(s) specified above is a contingency of this Agreement unless otherwise agreed in writing. Buyer's contractual obligations to obtain and provide deposit, balance of down payment and closing costs are not contingencies of this Agreement.

(3) LOAN CONTINGENCY REMOVAL:

(i) Within 17 (or) Days After Acceptance, Buyer shall, as specified in paragraph 19, in writing remove the loan contingency or cancel this Agreement;

OR (ii) If checked the loan contingency shall remain in effect until the designated loans are funded.

(4) NO LOAN CONTINGENCY (If checked): Obtaining any loan specified above is NOT a contingency of this Agreement. If Buyer does not obtain the loan and as a result Buyer does not purchase the Property, Seller may be entitled to Buyer's deposit or other legal remedies.

I. APPRAISAL CONTINGENCY AND REMOVAL: This Agreement is (OR, if checked, is NOT) contingent upon a written appraisal of the Property by a licensed or certified appraiser at no less than the specified purchase price. If there is a loan contingency, Buyer's removal of the loan contingency shall be deemed removal of this appraisal contingency (or; If checked, Buyer shall, as specified in paragraph 19B(3), in writing remove the appraisal contingency or cancel this Agreement within 17 (or) Days After Acceptance). If there is no loan contingency, Buyer shall, as specified in paragraph 19B(3), in writing remove the appraisal contingency or cancel this Agreement within 17 (or) Days After Acceptance.

J. ALL CASH OFFER (if checked): Buyer shall, within 7 (or) Days After Acceptance, Deliver to Seller written verification of sufficient funds to close this transaction. (If checked verification attached.)

K. BUYER STATED FINANCING: Seller has relied on Buyer's representation of the type of financing specified (including but not limited to, as applicable, amount of down payment, contingent or non contingent loan, or all cash). If Buyer seeks alternate financing, (i) Seller has no obligation to cooperate with Buyer's efforts to obtain such financing, and (ii) Buyer shall also pursue the financing method specified in this Agreement. Buyer's failure to secure alternate financing does not excuse Buyer from the obligation to purchase the Property and close escrow as specified in this Agreement.

L. SELLER FINANCING: The following terms (or (if checked) the terms specified in the attached Seller Financing Addendum (C.A.R. Form SFA) apply ONLY to financing extended by Seller under this Agreement.

(1) BUYER'S CREDIT-WORTHINESS: Buyer authorizes Seller and/or Brokers to obtain, at Buyer's expense, a copy of Buyer's credit report. Within 7 (or) Days After Acceptance, Buyer shall provide any supporting documentation reasonably requested by Seller.

(2) TERMS: Buyer's promissory note, deed of trust and other documents as appropriate shall incorporate and implement the following additional terms: (i) the maximum interest rate specified in paragraph 3C shall be the actual fixed interest rate for Seller financing; (ii) deed of trust shall contain a REQUEST FOR NOTICE OF DEFAULT on senior loans; (iii) Buyer shall sign and pay for a REQUEST FOR NOTICE OF DELINQUENCY prior to Close Of Escrow and at any future time if requested by Seller; (iv) note and deed of trust shall contain an acceleration clause making the loan due, when permitted by law and at Seller's option, upon the sale or transfer of the Property or any interest in it; (v) note shall contain a late charge of 6% of the installment due (or) if the installment is not received within 10 days of the date due; (vi) title insurance coverage in the form of a joint protection policy shall be provided insuring Seller's deed of trust interest in the Property (any increased cost over owner's policy shall be paid by Buyer); and (vii) tax service shall be obtained and paid for by Buyer to notify Seller if property taxes have not been paid.

(3) ADDED, DELETED OR SUBSTITUTED BUYERS: The addition, deletion or substitution of any person or entity under this Agreement or to title prior to Close Of Escrow shall require Seller's written consent. Seller may grant or withhold consent in Seller's sole discretion. Any additional or substituted person or entity shall, if requested by Seller, submit to Seller the same documentation as required for the original named Buyer. Seller and/or Brokers may obtain a credit report, at Buyer's expense, on any such person or entity.

M. ASSUMED OR "SUBJECT TO" FINANCING: Seller represents that Seller is not delinquent on any payments due on any loans. Seller shall, within the time specified in paragraph 19, provide Copies of all applicable notes and deeds of trust, loan balances and current interest rates to Buyer. Buyer shall then, as specified in paragraph 19B(3), remove this contingency or cancel this Agreement. Differences between estimated and actual loan balances shall be adjusted at Close Of Escrow by cash down payments in kind accounts, if any, shall be assigned and charged to Buyer and credited to Seller. Seller is advised that Buyer's assumption of an existing loan may not release Seller from liability on that loan. If this is an assumption of a VA Loan, the sale is contingent upon Seller being provided a release of liability and substitution of eligibility, unless otherwise agreed in writing. If the Property is acquired subject to an existing loan, Buyer and Seller are advised to consult with legal counsel regarding the ability of an existing lender to call the loan due, and the consequences thereof.

4. ALLOCATION OF COSTS (If checked): Unless otherwise specified in writing, this paragraph only determines who is to pay for the inspection, test or service ("Report") mentioned; it does not determine who is to pay for any work recommended or identified in the Report.

A. INSPECTIONS AND REPORTS:

- (1) Buyer Seller shall pay to have existing septic or private sewage disposal system, if any, inspected
(2) Buyer Seller shall pay for costs of testing to determine the suitability of soil for sewage disposal
(3) Buyer Seller shall pay to have existing wells, if any, tested for water quantity and productivity

Buyer's Initials ([Signature]) (_____)

Seller's Initials ([Signature]) (_____)



8. CONDOMINIUM/PLANNED UNIT DEVELOPMENT DISCLOSURES:

- A. SELLER HAS: 7 (or) Days After Acceptance to disclose to Buyer whether the Property is a condominium, or is located in a planned development or other common interest subdivision (C.A.R. Form VLQ).
- B. If the Property is a condominium, or located in a planned unit development or other common interest subdivision, Seller has 3 (or) Days After Acceptance to request from the HOA (C.A.R. Form HOA): (i) Copies of any documents required by Law; (ii) disclosure of any pending or anticipated claim or litigation by or against the HOA; (iii) a statement containing the location and number of designated parking and storage spaces; (iv) Copies of the most recent 12 months of HOA minutes for regular and special meetings; and (v) the names and contact information of all HOAs governing the Property (collectively, "CI Disclosures") and (vi) the following if Seller has actual knowledge: (a) any material defects in the condition of common area (such as pools, tennis courts, walkways or other areas co-owned in undivided interest with other); and (b) possible lack of compliance with HOA requirements. Seller shall itemize and deliver to Buyer all CI Disclosures received from the HOA and any CI Disclosures in Seller's possession. Buyer's approval of CI Disclosures is a contingency of this Agreement as specified in paragraph 14B(3).

9. **SUBSEQUENT DISCLOSURES:** In the event Seller, prior to Close Of Escrow, becomes aware of adverse conditions materially affecting the Property, or any material inaccuracy in disclosures, information or representations previously provided to Buyer of which Buyer is otherwise unaware, Seller shall promptly provide a subsequent or amended disclosure or notice, in writing, covering those items. However, a subsequent or amended disclosure shall not be required for conditions and material inaccuracies disclosed in reports ordered and paid for by Buyer.

10. CHANGES DURING ESCROW:

- A. Prior to Close Of Escrow, Seller may engage in the following acts ("Proposed Changes"), subject to Buyer's rights in paragraph 19: (i) rent or lease any part of the premises; (ii) alter, modify or extend any existing rental or lease agreement; (iii) enter into, alter, modify or extend any service contract(s); or (iv) change the status of the condition of the Property.
- B. At least 7 (or) Days prior to any Proposed Changes, Seller shall give written notice to Buyer of such Proposed Changes.

11. ITEMS INCLUDED AND EXCLUDED:

- A. **NOTE TO BUYER AND SELLER:** Items listed as included or excluded in the MLS, flyers or marketing materials are not included in the purchase price or excluded from the sale unless specified in 11B or C.
- B. **ITEMS INCLUDED IN SALE:**
 - (1) All EXISTING fixtures and fittings that are attached to the Property;
 - (2) The following items: _____
 - (3) Seller represents that all items included in the purchase price, unless otherwise specified, are owned by Seller.
 - (4) All items included shall be transferred free of liens and without Seller warranty.
- C. **ITEMS EXCLUDED FROM SALE:** _____

12. **CONDITION OF PROPERTY:** Unless otherwise agreed: (i) the Property is sold (a) in its PRESENT physical ("as-is") condition as of the date of Acceptance and (b) subject to Buyer investigation rights; (ii) the Property is to be maintained in substantially the same condition as of the date of Acceptance and (iii) (if checked) All debts and personal property not included in the sale shall be removed by Seller by Close Of Escrow.

- A. SELLER SHALL, within the time specified in paragraph 19, DISCLOSE KNOWN MATERIAL FACTS AND DEFECTS AFFECTING THE PROPERTY AND MAKE ALL OTHER DISCLOSURES REQUIRED BY LAW.
- B. Buyer has the right to inspect the Property and, as specified in paragraph 19B, based upon information discovered in those inspections: (i) cancel this Agreement; or (ii) request that Seller make Repairs or take other action.
- C. Buyer is strongly advised to conduct investigations of the entire Property in order to determine its present condition. Seller may not be aware of all defects affecting the Property or other factors that Buyer considers important. Property improvements may not be built according to code, in compliance with current Law, or have had permits issued.

13. BUYER'S INVESTIGATION OF PROPERTY AND MATTERS AFFECTING PROPERTY:

- A. Buyer's acceptance of the condition of, and any other matter affecting the Property, is a contingency of this Agreement as specified in this paragraph and paragraph 19B. Within the time specified in paragraph 19B(1), Buyer shall have the right, at Buyer's expense unless otherwise agreed, to conduct inspections, investigations, tests, surveys and other studies ("Buyer Investigations"), including, but not limited to, the right to: (i) inspect for lead-based paint and other lead-based paint hazards; (ii) inspect for wood destroying pests and organisms; (iii) review the registered sex offender database; (iv) confirm the insurability of Buyer and the Property; and (v) satisfy Buyer as to any matter specified in the attached Buyer's Inspection Advisory (C.A.R. Form BIA). Without Seller's prior written consent, Buyer shall neither make nor cause to be made: (i) invasive or destructive Buyer Investigations; or (ii) inspections by any governmental building or zoning inspector or government employee, unless required by Law.
- B. Seller shall make the Property available for all Buyer Investigations. Buyer shall (i) as specified in paragraph 19B, complete Buyer Investigations and, either remove the contingency or cancel this Agreement, and (ii) give Seller, at no cost, complete Copies of all Investigation reports obtained by Buyer, which obligation shall survive the termination of this Agreement.
- C. **Buyer indemnity and Seller protection for entry upon property:** Buyer shall: (i) keep the Property free and clear of liens; (ii) repair all damage arising from Buyer Investigations; and (iii) indemnify and hold Seller harmless from all resulting liability, claims, demands, damages and costs of Buyer's Investigations. Buyer shall carry, or Buyer shall require anyone acting on Buyer's behalf to carry, policies of liability, workers' compensation and other applicable insurance, defending and protecting Seller from liability for any injuries to persons or property occurring during any Buyer Investigations or work done on the Property at Buyer's direction prior to Close Of Escrow. Seller is advised that certain protections may be afforded Seller by recording a "Notice of Non-responsibility" (C.A.R. Form NNR) for Buyer Investigations and work done on the Property at Buyer's direction. Buyer's obligations under this paragraph shall survive the termination or cancellation of this Agreement and Close Of Escrow.

Buyer's Initials () ()

Seller's Initials () ()

Reviewed by _____ Date _____



D. BUYER IS STRONGLY ADVISED TO INVESTIGATE THE CONDITION AND SUITABILITY OF ALL ASPECTS OF THE PROPERTY AND ALL MATTERS AFFECTING THE VALUE OR DESIRABILITY OF THE PROPERTY, INCLUDING BUT NOT LIMITED TO, THE ITEMS SPECIFIED BELOW. IF BUYER DOES NOT EXERCISE THESE RIGHTS, BUYER IS ACTING AGAINST THE ADVICE OF BROKERS. BUYER UNDERSTANDS THAT ALTHOUGH CONDITIONS ARE OFTEN DIFFICULT TO LOCATE AND DISCOVER, ALL REAL PROPERTY CONTAINS CONDITIONS THAT ARE NOT READILY APPARENT AND THAT MAY AFFECT THE VALUE OR DESIRABILITY OF THE PROPERTY. BUYER AND SELLER ARE AWARE THAT BROKERS DO NOT GUARANTEE, AND IN NO WAY ASSUME RESPONSIBILITY FOR, THE CONDITION OF THE PROPERTY. BROKERS HAVE NOT AND WILL NOT VERIFY ANY OF THE ITEMS IN THIS PARAGRAPH 13, UNLESS OTHERWISE AGREED IN WRITING.

- E. SIZE, LINES, ACCESS AND BOUNDARIES: Lot size, property lines, legal or physical access and boundaries including features of the Property shared in common with adjoining landowners, such as walls, fences, roads and driveways, whose use or responsibility for maintenance may have an effect on the Property and any encroachments, easements or similar matters that may affect the Property. (Fences, hedges, walls and other natural or constructed barriers or markers do not necessarily identify true Property boundaries. Property lines may be verified by survey.) (Unless otherwise specified in writing, any numerical statements by Brokers regarding lot size are APPROXIMATIONS ONLY, which have not been and will not be verified, and should not be relied upon by Buyer.)
F. ZONING AND LAND USE: Past, present, or proposed laws, ordinances, referendums, initiatives, votes, applications and permits affecting the current use of the Property, future development, zoning, building, size, governmental permits and inspections. Any zoning violations, non-conforming uses, or violations of "setback" requirements. (Buyer should also investigate whether these matters affect Buyer's intended use of the Property.)
G. UTILITIES AND SERVICES: Availability, costs, restrictions and location of utilities and services, including but not limited to, sewerage, sanitation, septic and leach lines, water, electricity, gas, telephone, cable TV and drainage.
H. ENVIRONMENTAL HAZARDS: Potential environmental hazards, including, but not limited to, asbestos, lead-based paint and other lead contamination, radon, methane, other gases, fuel, oil or chemical storage tanks, contaminated soil or water, hazardous waste, waste disposal sites, electromagnetic fields, nuclear sources, and other substances, including mold (airborne, toxic or otherwise), fungus or similar contaminant, materials, products or conditions.
I. GEOLOGIC CONDITIONS: Geologic/seismic conditions, soil and terrain stability, suitability and drainage including any slippage, sliding, flooding, drainage, grading, fill (compactd or otherwise), or other soil problems.
J. NATURAL HAZARD ZONE: Special Flood Hazard Areas, Potential Flooding (Inundation) Areas, Very High Fire Hazard Zones, State Fire Responsibility Areas, Earthquake Fault Zones, Seismic Hazard Zones, or any other zone for which disclosure is required by Law.
K. PROPERTY DAMAGE: Major damage to the Property or any of the structures or non-structural systems and components and any personal property included in the sale from fire, earthquake, floods, landslides or other causes.
L. NEIGHBORHOOD, AREA AND PROPERTY CONDITIONS: Neighborhood or area conditions, including Agricultural Use Restrictions pursuant to the Williamson Act (Government Code §§51200-51295), Right To Farm Laws (Civil Code §§482.5 and §3482.6), schools, proximity and adequacy of law enforcement, crime statistics, the proximity of registered felons or offenders, fire protection, other government services, availability, adequacy and cost of any speed-wired, wireless internet connections or other telecommunications or other technology services and installations, proximity to commercial, industrial or agricultural activities, existing and proposed transportation, construction and development that may affect noise, view, or traffic, airport noise, noise or odor from any source, abandoned mining operations on the Property, wild and domestic animals, other nuisances, hazards, or circumstances, protected species, wetland properties, botanical diseases, historic or other governmentally protected sites or improvements, cemeteries, facilities and condition of common areas of common interest subdivisions, and possible lack of compliance with any governing documents or Homeowners' Association requirements, conditions and influences of significance to certain cultures and/or religions, and personal needs, requirements and preferences of Buyer.
M. COMMON INTEREST SUBDIVISIONS; OWNER ASSOCIATIONS: Facilities and condition of common areas (facilities such as pools, tennis courts, walkways, or other areas co-owned in undivided interest with others), Owners' Association that has any authority over the subject property, CC&Rs, or other deed restrictions or obligations, and possible lack of compliance with any Owners' Association requirements.
N. SPECIAL TAX: Any local agencies that levy a special tax on the Property pursuant to the Mello-Roos Community Facilities Act or Improvement Bond Act of 1915.
O. RENTAL PROPERTY RESTRICTIONS: Some cities and counties impose restrictions that limit the amount of rent that can be charged, the maximum number of occupants and the right of a landlord to terminate a tenancy.
P. MANUFACTURED HOME PLACEMENT: Conditions that may affect the ability to place and use a manufactured home on the Property.

14. SELLER DISCLOSURES; ADDENDA; ADVISORIES; OTHER TERMS:

A. Seller Disclosures (if checked): Seller shall, within the time specified in paragraph 19A, complete and provide Buyer with a:
[] Seller Vacant Land Questionnaire (C.A.R. Form VLQ)
B. Addenda (if checked):
[] Wood Destroying Pest Inspection and Allocation of Cost Addendum (C.A.R. Form WPA)
[] Purchase Agreement Addendum (C.A.R. Form PAA)
[] Short Sale Addendum (C.A.R. Form SSA)
[] Septic, Well and Property Monument Addendum (C.A.R. Form SWPM)
[] Other
C. Advisories (if checked):
[] Buyer's Inspection Advisory (C.A.R. Form BIA)
[] Probate Advisory (C.A.R. Form PAK)
[] Statewide Buyer and Seller Advisory (C.A.R. Form SBBSA)
[] Trust Advisory (C.A.R. Form TA)
[] REO Advisory (C.A.R. Form REO)
D. Other Terms: Seller Vacant Land Questionnaire dated 2/14/10 incorporated herein; The Seller shall deliver marketable Title to the Buyer Free of Liens and Encumbrances. Land bench mark survey, Preliminary Title Report that the Buyer to approve or disapprove from 30 days receipt provided by Chicago Title Company.

Buyer's Initials ([Signature]) (_____)

Seller's Initials ([Signature]) (_____)

Reviewed by _____ Date _____



15. TITLE AND VESTING:

- A. Within the time specified in paragraph 19, Buyer shall be provided a current preliminary title report, which shall include a search of the General Index, Seller shall within 7 Days After Acceptance, give Escrow Holder a completed Statement of Information. The preliminary report is only an offer by the title insurer to issue a policy of title insurance and may not contain every item affecting title. Buyer's review of the preliminary report and any other matters which may affect title are a contingency of this Agreement as specified in paragraph 19B.
- B. Title is taken in its present condition subject to all encumbrances, easements, covenants, conditions, restrictions, rights and other matters, whether of record or not, as of the date of Acceptance except: (i) monetary liens of record unless Buyer is assuming those obligations or taking the Property subject to those obligations; and (ii) those matters which Seller has agreed to remove in writing.
- C. Within the time specified in paragraph 19, Seller has a duty to disclose to Buyer all matters known to Seller affecting title, whether of record or not.
- D. At Close Of Escrow, Buyer shall receive a grant deed conveying title (or, for stock cooperative or long-term lease, an assignment of stock certificate or of Seller's leasehold interest), including oil, mineral and water rights if currently owned by Seller. Title shall vest as designated in Buyer's supplemental escrow instructions. THE MANNER OF TAKING TITLE MAY HAVE SIGNIFICANT LEGAL AND TAX CONSEQUENCES. CONSULT AN APPROPRIATE PROFESSIONAL.
- E. Buyer shall receive a standard coverage owner's CLTA policy of title insurance. An ALTA policy or the addition of endorsements may provide greater coverage for Buyer. A title company, at Buyer's request, can provide information about the availability, desirability, coverage, survey requirements, and cost of various title insurance coverages and endorsements. If Buyer desires title coverage other than that required by this paragraph, Buyer shall instruct Escrow Holder in writing and pay any increase in cost.

16. SALE OF BUYER'S PROPERTY:

A. This Agreement is NOT contingent upon the sale of any property owned by Buyer.

OR B. (if checked) The attached addendum (C.A.R. Form COE) regarding the contingency for the sale of property owned by Buyer is incorporated into this Agreement.

~~17. MANUFACTURED HOME PURCHASE (if checked): The purchase of the Property is contingent upon Buyer acquiring a personal property manufactured home to be placed on the Property after Close Of Escrow. Buyer has has not entered into a contract for the purchase of a personal property manufactured home. Within the time specified in paragraph 19, Buyer shall remove this contingency or cancel this Agreement, (OR, if checked this contingency shall remain in effect until the Close Of Escrow of the Property).~~

~~18. CONSTRUCTION LOAN FINANCING (if checked): The purchase of the Property is contingent upon Buyer obtaining a construction loan. A draw from the construction loan will will not be used to finance the Property. Within the time specified in paragraph 19, Buyer shall remove this contingency or cancel this Agreement (or, if checked, this contingency shall remain in effect until Close Of Escrow of the Property).~~

~~19. TIME PERIODS; REMOVAL OF CONTINGENCIES; CANCELLATION RIGHTS: The following time periods may only be extended, altered, modified or changed by mutual written agreement. Any removal of contingencies or cancellation under this paragraph by either Buyer or Seller must be exercised in good faith and in writing (C.A.R. Form CR or CC).~~

~~A. SELLER HAS: 7 (or _____) Days After Acceptance to Deliver to Buyer all Reports, disclosures and information for which Seller is responsible under paragraphs 3M, 4, 6A and B, 7, 8A, 12A, 14A and B, and 15. Buyer may give Seller a Notice to Seller to Perform (C.A.R. Form NSP) if Seller has not Delivered the items within the time specified.~~

~~B. (1) BUYER HAS: 17 (or 20) Days After Acceptance, unless otherwise agreed in writing, to complete all Buyer Investigations; approve all disclosures, reports and other applicable information, which Buyer receives from Seller; and approve all other matters affecting the Property (including lead-based paint and lead-based paint hazards as well as other information specified in paragraph 6 and insurability of Buyer and the Property).~~

~~(2) Within the time specified in 19B(1), Buyer may request that Seller make repairs or take any other action regarding the Property (C.A.R. Form RR). Seller has no obligation to agree to or respond to Buyer's requests.~~

~~(3) Within the time specified in 19B(1) (or as otherwise specified in this Agreement), Buyer shall, Deliver to Seller either (i) a removal of the applicable contingency (C.A.R. Form CR), or (ii) a cancellation (C.A.R. Form CC) of this Agreement based upon a remaining contingency or Seller's failure to Deliver the specified items. However, if any report, disclosure or information for which Seller is responsible is not Delivered within the time specified in 19A, then Buyer has 5 (or _____) Days After Delivery of any such items, or the time specified in 19B(1), whichever is later, to Deliver to Seller a removal of the applicable contingency or cancellation of this Agreement.~~

~~(4) Continuation of Contingency: Even after the end of the time specified in 19B(1) and before Seller cancels this Agreement, if at all pursuant to 19C, Buyer retains the right to either (i) in writing remove remaining contingencies, or (ii) cancel this Agreement based upon a remaining contingency or Seller's failure to Deliver the specified items. Once Buyer's written removal of all contingencies is Delivered to Seller, Seller may not cancel this Agreement pursuant to 19C(1).~~

~~C. SELLER RIGHT TO CANCEL:~~

~~(1) Seller right to Cancel; Buyer Contingencies: If, within the time specified in this Agreement, Buyer does not, in writing, Deliver to Seller a removal of the applicable contingency or cancellation of this Agreement then Seller, after first Delivering to Buyer a Notice to Buyer to Perform (C.A.R. Form NBP) may cancel this Agreement. In such event, Seller shall authorize return of Buyer's deposit.~~

~~(2) Seller right to Cancel; Buyer Contract Obligations: Seller, after first Delivering to Buyer a NBP may cancel this Agreement for any of the following reasons: (i) if Buyer fails to deposit funds as required by 3A or 3B; (ii) if the funds deposited pursuant to 3A or 3B are not good when deposited; (iii) if Buyer fails to Deliver a loan as required by 3H; (iv) if Buyer fails to Deliver verification as required by 3G or 3J; or (v) if Seller reasonably disapproves of the verification provided by 3G or 3J or the credit report or supporting documentation pursuant to 3M. In such event, Seller shall authorize return of Buyer's deposit.~~

~~(3) Notice To Buyer To Perform: The NBP shall: (i) be in writing; (ii) be signed by Seller; and (iii) give Buyer at least 2 (or _____) Days After Delivery (or until the time specified in the applicable paragraph, whichever occurs last) to take the applicable action. A NBP may not be Delivered any earlier than 2 Days Prior to the expiration of the applicable time for Buyer to remove a contingency or cancel this Agreement or meet an obligation specified in 19C(2).~~

~~D. EFFECT OF BUYER'S REMOVAL OF CONTINGENCIES: If Buyer removes, in writing, any contingency or cancellation rights, unless otherwise specified in a separate written agreement between Buyer and Seller, Buyer shall with regard to that contingency or cancellation right conclusively be deemed to have: (i) completed all Buyer Investigations, and review of reports and other applicable information and disclosures; (ii) elected to proceed with the transaction; and (iii) assumed all liability, responsibility and expense for Repairs or corrections or for inability to obtain financing.~~

Buyer's Initials (MP) (_____)

Seller's Initials (ll) (_____)



- E. **CLOSE OF ESCROW:** Before Seller or Buyer may cancel this Agreement for failure of the other party to close escrow pursuant to this Agreement, Seller or Buyer must first give the other a demand to close escrow (C.A.R. Form DCÉ).
 - F. **EFFECT OF CANCELLATION ON DEPOSITS:** If Buyer or Seller gives written notice of cancellation pursuant to rights duly exercised under the terms of this Agreement, Buyer and Seller agree to Sign mutual instructions to cancel the sale and escrow and release deposits, if any, to the party entitled to the funds, less fees and costs incurred by that party. Fees and costs may be payable to service providers and vendors for services and products provided during escrow. Release of funds will require mutual Signed release instructions from Buyer and Seller, judicial decision or arbitration award.
 - 20. **FINAL VERIFICATION OF CONDITION:** Buyer shall have the right to make a final inspection of the Property within 5 (or _____) Days Prior to Close Of Escrow, NOT AS A CONTINGENCY OF THE SALE, but solely to confirm: (i) the Property is maintained pursuant to paragraph 12; (ii) Repairs have been completed as agreed; and (iii) Seller has complied with Seller's other obligations under this Agreement (C.A.R. FORM VP).
 - 21. **ENVIRONMENTAL HAZARD CONSULTATION:** Buyer and Seller acknowledge: (i) Federal, state, and local legislation impose liability upon existing and former owners and users of real property, in applicable situations, for certain legislatively defined, environmentally hazardous substances; (ii) Broker(s) has/have made no representation concerning the applicability of any such Law to this transaction or to Buyer or to Seller, except as otherwise indicated in this Agreement; (iii) Broker(s) has/have made no representation concerning the existence, testing, discovery, location and evaluation of/or, and risks posed by, environmentally hazardous substances, if any, located on or potentially affecting the Property; and (iv) Buyer and Seller are each advised to consult with technical and legal experts concerning the existence, testing, discovery, location and evaluation of/or, and risks posed by, environmentally hazardous substances, if any, located on or potentially affecting the Property.
 - 22. **PRORATIONS OF PROPERTY TAXES AND OTHER ITEMS:** Unless otherwise agreed in writing, the following items shall be PAID CURRENT and prorated between Buyer and Seller as of Close Of Escrow: real property taxes and assessments, interest, rents, HOA regular, special, and emergency dues and assessments imposed prior to Close Of Escrow, premiums on insurance assumed by Buyer, payments on bonds and assessments assumed by Buyer, and payments on Mello-Roos and other Special Assessment District bonds and assessments that are a current lien. The following items shall be assumed by Buyer WITHOUT CREDIT toward the purchase price: prorated payments on Mello-Roos and other Special Assessment District bonds and assessments and HOA special assessments that are a current lien but not yet due. The Property will be reassessed upon change of ownership. Any supplemental tax bills shall be paid as follows: (i) for periods after Close Of Escrow, by Buyer; and (ii) for periods prior to Close Of Escrow, by Seller. See C.A.R. Form SPT or SBBA for further information. TAX BILLS ISSUED AFTER CLOSE OF ESCROW SHALL BE HANDLED DIRECTLY BETWEEN BUYER AND SELLER. Prorations shall be made based on a 30-day month.
 - 23. **SELECTION OF SERVICE PROVIDERS:** Brokers do not guarantee the performance of any vendors, service or product providers ("Providers"), whether referred by Broker or selected by Buyer, Seller or other person. Buyer and Seller may select ANY Providers of their own choosing.
 - 24. **MULTIPLE LISTING SERVICE/PROPERTY DATA SYSTEM:** If Broker is a participant of a Multiple Listing Service ("MLS") or Property Data System ("PDS"), Broker is authorized to report to the MLS or PDS a pending sale and, upon Close Of Escrow, the sales price and other terms of this transaction shall be produced to the MLS to be published and disseminated to persons and entities authorized to use the information on this approved by the MLS or PDS.
 - 25. **EQUAL HOUSING OPPORTUNITY:** The Property is sold in compliance with federal, state and local anti-discrimination Laws.
 - 26. **ATTORNEY FEES:** In any action, proceeding, or arbitration between Buyer and Seller arising out of this Agreement, the prevailing Buyer or Seller shall be entitled to reasonable attorney fees and costs from the non-prevailing Buyer or Seller, except as provided in paragraph 31A.
 - 27. **DEFINITIONS:** As used in this Agreement:
 - A. "Acceptance" means the time the offer or final counter offer is accepted in writing by a party and is delivered to and personally received by the other party or that party's authorized agent in accordance with the terms of this offer or a final counter offer.
 - B. "C.A.R. Form" means the specific form referenced or another comparable form agreed to by the parties.
 - C. "Close Of Escrow" means the date the grant deed, or other evidence of transfer of title, is recorded.
 - D. "Copy" means copy by any means including photocopy, NCR, facsimile and electronic.
 - E. "Days" means calendar days. However, after Acceptance, the last Day for performance of any act required by this Agreement (including Close Of Escrow) shall not include any Saturday, Sunday, or legal holiday and shall instead be the next Day.
 - F. "Days After" means the specified number of calendar days after the occurrence of the event specified, not counting the calendar date on which the specified event occurs, and ending at 11:59 PM on the final day.
 - G. "Days Prior" means the specified number of calendar days before the occurrence of the event specified, not counting the calendar date on which the specified event is scheduled to occur.
 - H. "Deliver", "Delivered" or "Delivery", regardless of the method used (i.e. messenger, mail, email, fax, other), means and shall be effective upon (i) personal receipt by Buyer or Seller or the individual Real Estate Licensee for that principal as specified in paragraph D of the section titled Real Estate Brokers on page 8;
 - OR (i) if checked, per the attached addendum (C.A.R. Form RDN).
 - I. "Electronic Copy" or "Electronic Signature" means, as applicable, an electronic copy or signature complying with California Law. Buyer and Seller agree that electronic means will not be used by either party to modify or alter the content or integrity of this Agreement without the knowledge and consent of the other party.
 - J. "Law" means any law, code, statute, ordinance, regulation, rule or order, which is adopted by a controlling city, county, state or federal legislative, judicial or executive body or agency.
 - K. "Repairs" means any repairs (including pest control), alterations, replacements, modifications or retrofitting of the Property provided for under this Agreement.
 - L. "Signed" means either a handwritten or electronic signature on an original document, Copy or any counterpart.
28. **BROKERS:**
 - A. ~~BROKER COMPENSATION~~ Seller or Buyer, or both, as applicable, agrees to pay compensation to Broker as specified in a separate written agreement between Broker and that ~~Seller or Buyer~~. Compensation is payable upon Close Of Escrow, or if escrow does not close, as otherwise specified in the agreement between Broker and that Seller or Buyer.

Buyer's Initials () ()

Seller's Initials () ()



B. SCOPE OF BROKER DUTY: Buyer and Seller acknowledge and agree that; Brokers: (i) do not decide what price Buyer should pay or Seller should accept; (ii) do not guarantee the condition of the Property; (iii) do not guarantee the performance, adequacy or completeness of inspections, services, products or repairs provided or made by Seller or others; (iv) shall not be responsible for identifying defects that are not known to Broker(s); (v) shall not be responsible for inspecting public records or permits concerning the title or use of the Property; (vi) shall not be responsible for identifying location of boundary lines or other items affecting title; (vii) shall not be responsible for verifying square footage, representations of others or information contained in inspection reports, MLS or PDS, advertisements, flyers or other promotional material, unless otherwise agreed in writing; (viii) shall not be responsible for providing legal or tax advice regarding any aspect of a transaction entered into by Buyer or Seller in the course of this representation; and (ix) shall not be responsible for providing other advice or information that exceeds the knowledge, education and experience required to perform real estate licensed activity. Buyer and Seller agree to seek legal, tax, insurance, title and other desired assistance from appropriate professionals.

29. JOINT ESCROW INSTRUCTIONS TO ESCROW HOLDER:

A. The following paragraphs, or applicable portions thereof, of this Agreement constitute the joint escrow instructions of Buyer and Seller to Escrow Holder, which Escrow Holder is to use along with any related counter offers and addenda, and any additional mutual instructions to close the escrow: 1, 3, 4, 6B, 14B and D, 15, 16B, 17, 18, 19F, 22, 27, 28A, 29, 33, 35, and paragraph D of the section titled Real Estate Brokers on page 10. If a Copy of the separate compensation agreement(s) provided for in paragraph 28A, or paragraph D of the section titled Real Estate Brokers on page 10 is deposited with Escrow Holder by Broker, Escrow Holder shall accept such agreement(s) and pay out of Buyer's or Seller's funds, or both, as applicable, the respective Broker's compensation provided for in such agreement(s). The terms and conditions of this Agreement not specifically referenced above in the specified paragraphs are additional matters for the information of Escrow Holder, but about which Escrow Holder need not be concerned. Buyer and Seller will receive Escrow Holder's general provisions directly from Escrow Holder and will execute such provisions upon Escrow Holder's request. To the extent the general provisions are inconsistent or conflict with this Agreement, the general provisions will control as to the duties and obligations of Escrow Holder only. Buyer and Seller will execute additional instructions, documents and forms provided by Escrow Holder that are reasonably necessary to close the escrow.

B. A Copy of this Agreement shall be delivered to Escrow Holder within 3 business days after Acceptance (or N/A _____), Escrow Holder shall provide Seller's Statement of Information to Title company when received from Seller. Buyer and Seller authorize Escrow Holder to accept and rely on Copies and Signatures as defined in this Agreement as originals, to open escrow and for other purposes of escrow. The validity of this Agreement as between Buyer and Seller is not affected by whether or when Escrow Holder Signs this Agreement.

C. Brokers are a party to the escrow for the sole purpose of compensation pursuant to paragraph 28A and paragraph D of the section titled Real Estate Brokers on page 10. Buyer and Seller irrevocably assign to Brokers compensation specified in paragraph 28A, respectively, and irrevocably instruct Escrow Holder to disburse those funds to Brokers at Close Of Escrow or pursuant to any other mutually executed cancellation agreement. Compensation Instructions can be amended or revoked only with the written consent of Brokers. Buyer and Seller shall release and hold harmless Escrow Holder from any liability resulting from Escrow Holder's payment to Broker(s) of compensation pursuant to this Agreement. Escrow Holder shall immediately notify Brokers: (i) if Buyer's initial or any additional deposit is not made pursuant to this Agreement, or is not good at time of deposit with Escrow Holder; or (ii) if either Buyer or Seller instruct Escrow Holder to cancel escrow.

D. A Copy of any amendment that affects any paragraph of this Agreement for which Escrow Holder is responsible shall be delivered to Escrow Holder within 2 business days after mutual execution of the amendment.

30. LIQUIDATED DAMAGES: If Buyer fails to complete this purchase because of Buyer's default, Seller shall retain, as liquidated damages, the deposit actually paid. Buyer and Seller agree that this amount is a reasonable sum given that it is impractical or extremely difficult to establish the amount of damages that would actually be suffered by Seller in the event Buyer were to breach this Agreement. Release of funds will require mutual, Signed release instructions from both Buyer and Seller, judicial decision or arbitration award.

Buyer's Initials [Signature] Seller's Initials [Signature]

31. DISPUTE RESOLUTION:

A. MEDIATION: Buyer and Seller agree to mediate any dispute or claim arising between them out of this Agreement, or any resulting transaction, before resorting to arbitration or court action. Buyer and Seller also agree to mediate any disputes or claims with Broker(s), who, in writing, agree to such mediation prior to, or within a reasonable time after, the dispute or claim is presented to the Broker. Mediation fees, if any, shall be divided equally among the parties involved. If, for any dispute or claim to which this paragraph applies, any party (i) commences an action without first attempting to resolve the matter through mediation, or (ii) before commencement of an action, refuses to mediate after a request has been made, then that party shall not be entitled to recover attorney fees, even if they would otherwise be available to that party in any such action. THIS MEDIATION PROVISION APPLIES WHETHER OR NOT THE ARBITRATION PROVISION IS INITIALED. Exclusions from this mediation agreement are specified in paragraph 31C.

B. ARBITRATION OF DISPUTES:

Buyer and Seller agree that any dispute or claim in Law or equity arising between them out of this Agreement or any resulting transaction, which is not settled through mediation, shall be decided by neutral, binding arbitration. Buyer and Seller also agree to arbitrate any disputes or claims with Broker(s), who, in writing, agree to such arbitration prior to, or within a reasonable time after, the dispute or claim is presented to the Broker. The arbitrator shall be a retired judge or justice, or an attorney with at least 5 years of residential real estate Law experience, unless the parties mutually agree to a different arbitrator. The parties shall have the right to discovery in accordance with Code of Civil Procedure §1283.05. In all other respects, the arbitration shall be conducted in accordance with Title 9 of Part 3 of the Code of Civil Procedure. Judgment upon the award of the arbitrator(s) may be entered into any court having jurisdiction. Enforcement of this agreement to arbitrate shall be governed by the Federal Arbitration Act. Exclusions from this arbitration agreement are specified in paragraph 31C.

Buyer's Initials ([Signature]) (_____)

Seller's Initials ([Signature]) (_____)



"NOTICE: BY INITIALING IN THE SPACE BELOW YOU ARE AGREEING TO HAVE ANY DISPUTE ARISING OUT OF THE MATTERS INCLUDED IN THE 'ARBITRATION OF DISPUTES' PROVISION DECIDED BY NEUTRAL ARBITRATION AS PROVIDED BY CALIFORNIA LAW AND YOU ARE GIVING UP ANY RIGHTS YOU MIGHT POSSESS TO HAVE THE DISPUTE LITIGATED IN A COURT OR JURY TRIAL. BY INITIALING IN THE SPACE BELOW YOU ARE GIVING UP YOUR JUDICIAL RIGHTS TO DISCOVERY AND APPEAL, UNLESS THOSE RIGHTS ARE SPECIFICALLY INCLUDED IN THE 'ARBITRATION OF DISPUTES' PROVISION. IF YOU REFUSE TO SUBMIT TO ARBITRATION AFTER AGREEING TO THIS PROVISION, YOU MAY BE COMPELLED TO ARBITRATE UNDER THE AUTHORITY OF THE CALIFORNIA CODE OF CIVIL PROCEDURE. YOUR AGREEMENT TO THIS ARBITRATION PROVISION IS VOLUNTARY."

"WE HAVE READ AND UNDERSTAND THE FOREGOING AND AGREE TO SUBMIT DISPUTES ARISING OUT OF THE MATTERS INCLUDED IN THE 'ARBITRATION OF DISPUTES' PROVISION, TO NEUTRAL ARBITRATION."

Buyer's Initials [Signature] Seller's Initials [Signature]

C. ADDITIONAL MEDIATION AND ARBITRATION TERMS:

- (1) EXCLUSIONS: The following matters shall be excluded from mediation and arbitration: (i) a judicial or non-judicial foreclosure or other action or proceeding to enforce a deed of trust, mortgage or installment land sale contract as defined in Civil Code §2985; (ii) an unlawful detainer action; (iii) the filing or enforcement of a mechanic's lien; and (iv) any matter that is within the jurisdiction of a probate, small claims or bankruptcy court. The filing of a court action to enable the recording of a notice of pending action, for order of attachment, receivership, injunction, or other provisional remedies, shall not constitute a waiver or violation of the mediation and arbitration provisions.
(2) BROKERS: Brokers shall not be obligated or compelled to mediate or arbitrate unless they agree to do so in writing. Any Broker(s) participating in mediation or arbitration shall not be deemed a party to the Agreement.

32. TERMS AND CONDITIONS OF OFFER:

This is an offer to purchase the Property on the above terms and conditions. The liquidated damages paragraph or the arbitration of disputes paragraph is incorporated in this Agreement if initialed by all parties or if incorporated by mutual agreement in a counter offer or addendum. If at least one but not all parties initial such paragraph(s), a counter offer is required until agreement is reached. Seller has the right to continue to offer the Property for sale and to accept any other offer at any time prior to notification of Acceptance. If this offer is accepted and Buyer subsequently defaults, Buyer may be responsible for payment of Brokers' compensation. This Agreement and any supplement, addendum or modification, including any Copy, may be Signed in two or more counterparts, all of which shall constitute one and the same writing.

33. TIME OF ESSENCE; ENTIRE CONTRACT; CHANGES:

Time is of the essence. All understandings between the parties are incorporated in this Agreement. Its terms are intended by the parties as a final, complete and exclusive expression of their Agreement with respect to its subject matter, and may not be contradicted by evidence of any prior agreement or contemporaneous oral agreement. If any provision of this Agreement is held to be ineffective or invalid, the remaining provisions will nevertheless be given full force and effect. Except as otherwise specified, this Agreement shall be interpreted and disputes shall be resolved in accordance with the laws of the State of California. Neither this Agreement nor any provision in it may be extended, amended, modified, altered or changed, except in writing Signed by Buyer and Seller.

34. EXPIRATION OF OFFER:

This offer shall be deemed revoked and the deposit shall be returned unless the offer is Signed by Seller and a Copy of the Signed offer is personally received by Buyer, or by N/A who is authorized to receive it, by 5:00 PM on the third Day after this offer is signed by Buyer (or, if checked, by AM PM, on (date)).

Buyer has read and acknowledges receipt of a Copy of the offer and agrees to the above confirmation of agency relationships.

Date 5/13/2019 BUYER City of Beaumont, a municipal corporation (Print name)

Date 5/13/2019 BUYER Todd Parton, City Manager (Print name)

(Address)

Additional Signature Addendum attached (C.A.R. Form ASA).

35. ACCEPTANCE OF OFFER: Seller warrants that Seller is the owner of the Property, or has the authority to execute this Agreement. Seller accepts the above offer, agrees to sell the Property on the above terms and conditions, and agrees to the above confirmation of agency relationships. Seller has read and acknowledges receipt of a Copy of this Agreement, and authorizes Broker to Deliver a Signed Copy to Buyer.

(If checked) SUBJECT TO ATTACHED COUNTER OFFER (C.A.R. Form CO) DATED:

Date SELLER VAS, LLC, A California Limited Liability Company (Print name)

Date SELLER David P. Milecki, single member (Print name)

(Address)

Additional Signature Addendum attached (C.A.R. Form ASA).

(Initials) Confirmation of Acceptance: A Copy of Signed Acceptance was personally received by Buyer or Buyer's authorized agent on (date) at AM PM. A binding Agreement is created when a Copy of Signed Acceptance is personally received by Buyer or Buyer's authorized agent whether or not confirmed in this document. Completion of this confirmation is not legally required in order to create a binding Agreement; It is solely intended to evidence the date that Confirmation of Acceptance has occurred.

Buyer's Initials (Signature)

Seller's Initials (Signature)



REAL ESTATE BROKERS:

A. Real Estate Brokers are not parties to the Agreement between Buyer and Seller.
 B. Agency relationships are confirmed as stated in paragraph 2.
 C. If specified in paragraph 3A(2), Agent who submitted the offer for Buyer acknowledges receipt of deposit.
 D. **COOPERATING BROKER COMPENSATION:** Listing Broker agrees to pay Cooperating Broker (Selling Firm) and Cooperating Broker agrees to accept, out of Listing Broker's proceeds in escrow: (I) the amount specified in the MLS, provided Cooperating Broker is a Participant of the MLS in which the Property is offered for sale or a reciprocal MLS; or (II) (if checked) the amount specified in a separate written agreement (C.A.R. Form CBC) between Listing Broker and Cooperating Broker. Declaration of License and Tax (C.A.R. Form DLT) may be used to document that tax reporting will be required or that an exemption exists.

Real Estate Broker (Selling Firm) None BRE Lic. # _____
 By None Date _____
 Address _____ City _____ State _____ Zip _____
 Telephone _____ Fax _____ E-mail _____

Real Estate Broker (Listing Firm) None BRE Lic. # _____
 By None Date _____
 Address _____ City _____ State _____ Zip _____
 Telephone _____ Fax _____ E-mail _____

ESCROW HOLDER ACKNOWLEDGMENT:

Escrow Holder acknowledges receipt of a Copy of this Agreement, (If checked, a deposit in the amount of \$ _____), counter offer(s) numbered _____ Seller's Statement of Information and Other _____, and agrees to act as Escrow Holder subject to paragraph 29 of this Agreement, any supplemental escrow instructions and the terms of Escrow Holder's general provisions, if any.

Escrow Holder is advised that the date of Confirmation of Acceptance of the Agreement as between Buyer and Seller is _____

Escrow Holder _____ Escrow # _____
 By _____ Date _____
 Address _____
 Phone/Fax/E-mail _____

Escrow Holder is licensed by the California Department of Corporations, Insurance, Real Estate. License # _____

PRESENTATION OF OFFER: (_____) Listing Broker presented this offer to Seller on _____ (date).
 Broker or Designee Initials _____

REJECTION OF OFFER: (_____) (_____) No counter offer is being made. This offer was rejected by Seller on _____ (date).
 Seller's Initials _____

cl

i n c Published and Distributed by:
 REAL ESTATE BUSINESS SERVICES, INC.
 a subsidiary of the CALIFORNIA ASSOCIATION OF REALTORS®
 525 South Virgil Avenue, Los Angeles, California 90020

Reviewed by Date _____



ADDENDUM

NO. ONE

The following terms and conditions are hereby incorporated in and made a part of the May 13, 2019 Purchase Agreement for property know as Vacant Land APN: 417-110-018: SWC Fourth Street/Viele Avenue, City of Beaumont, CA 92223 in which City of Beaumont, a municipal corp, its manager, Todd Parton, City Manager is referred to as ("Buyer/Tenant") and V4B LLC, a California Limited Liability Company, David P. Mileski, single member is referred to as ("Seller/Landlord").

Seller is a limited liability company properly operating through one member identified in the LLC articles of organization. Seller shall provide articles of organization and a written operating statement, such document must be executed by one/single member.

The foregoing terms and conditions are hereby agreed to by the undersigned parties.

Date: 5/13/2019

Buyer: _____
City of Beaumont, a municipal corp.

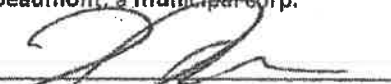
Buyer: 
Todd Parton, City Manager

Date: 5-14-19

Seller: _____
V4B LLC, A California Limited Liability Company

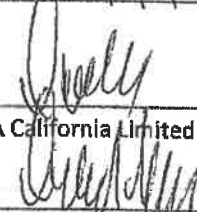
Seller: 
David P. Mileski, single member



CALIFORNIA
ASSOCIATION
OF REALTORS®

SELLER VACANT LAND QUESTIONNAIRE
(C.A.R. Form VLQ, 11/12)

I. Seller makes the following disclosures with regard to the real property described as Vacant Land APN: 417-110-018; SWC Fourth Street, Assessor's Parcel No. 417-110-018, situated in City of Bealmont, California ("Property").
County of Riverside

II. The following are representations made by the Seller. Unless otherwise specified in writing, Broker and any real estate licensee or other person working with or through Broker have not verified information provided by Seller. A real estate broker is qualified to advise on real estate transactions. If Seller or Buyer desire legal advice, they should consult an attorney.

III. Note to Seller: PURPOSE: To tell the Buyer about known material or significant items affecting the value or desirability of the Property and help to eliminate misunderstandings about the condition of the Property.
• Answer based on actual knowledge and recollection at this time.
• Something that you do not consider material or significant may be perceived differently by a Buyer.
• Think about what you would want to know if you were buying the Property today.
• Read the questions carefully and take your time.

IV. Note to Buyer: PURPOSE: To give you more information about known material or significant items affecting the value or desirability of the Property and help to eliminate misunderstandings about the condition of the Property.
• Something that may be material or significant to you, may not be perceived the same way by the Seller.
• If something is important to you, be sure to put your concerns and questions in writing (C.A.R. Form BM1).
• Sellers can only disclose what they actually know. Seller may not know about all material or significant items.
• Seller's disclosures are not a substitute for your own investigations, personal judgments or common sense.

V. SELLER AWARENESS: For each statement below, answer the question "Are you (Seller) aware of..." by checking either "Yes" or "No." Provide explanations to answers in the space provided or attach additional comments and check section VI.

- BOUNDARIES, ACCESS AND PROPERTY USE BY OTHERS:** ARE YOU (SELLER) AWARE OF...
1. Surveys, markers, stakes, pins or maps showing the location of the Property Yes No
 2. Any unrecorded easement, encroachment or other dispute, maintenance or use agreement affecting access to, or the boundaries of, the Property Yes No
 3. Use of the Property, or any part of it, by anyone other than you, with or without permission, for any purpose, including but not limited to, using or maintaining roads, driveways or other forms of ingress or egress, or other travel or drainage Yes No
 4. Leases, rental agreements, service contracts, licenses, permits or related agreements regarding use of the Property by others Yes No
 5. Use of any neighboring property by you Yes No
 6. The absence or limitation of legal or physical access to the Property Yes No

Explanation: _____

- GEOLOGIC CONDITIONS AND ENVIRONMENTAL HAZARDS:** ARE YOU (SELLER) AWARE OF...
7. Fill (compacted or otherwise), soil instability, caves, mines, cavams, or slippage on the Property Yes No
 8. Radon, methane or other gases, contaminated soil or water, hazardous waste, or waste disposal sites on the Property Yes No
 9. Fuel, oil or chemical storage tanks above or underground Yes No
 10. Past or present treatment or eradication of pests or odors Yes No

Explanation: _____

Buyer's Initials [Signature]

Seller's Initials [Signature]

© 2008-2012, California Association of REALTORS®, Inc.

VLQ REVISED 11/12 (PAGE 1 OF 4)

SELLER VACANT LAND QUESTIONNAIRE (VLQ PAGE 1 OF 4)



Property Address: Vacant Land APN: 417-110-018 ; SWC Fourth Street/Viola Avenue, City of Beaumont, CA 92223

Date: February 14, 2019

GOVERNMENTAL:

ARE YOU (SELLER) AWARE OF..

- 11. Agricultural use restrictions pursuant to the Williamson Act or other law
12. Whether the Property is in or adjacent to an area with Right to Farm rights
13. Presence of any endangered, threatened, "candidate" species, wetlands, historic artifacts or human remains on the Property
14. Any protected habitat for plants, trees, animals or insects that apply to or could affect the Property
15. Conditions or laws that may affect the ability to place and/or use a manufactured home on the Property
16. Special taxes pursuant to the Mello-Ross Community Facilities Act, Improvement Bond Act of 1915 or other law
17. Ongoing or contemplated eminent domain, condemnation, annexation or change in zoning or general plan that apply to or could affect the Property
18. Existence or pendency of any rent control, occupancy restrictions or retrofit requirements that apply to or could affect the Property
19. Existing or contemplated building or use moratorium that apply to or could affect the Property
20. Current or proposed bonds, assessments, or fees that do not appear on the Property tax bill that apply to or could affect the Property
21. Proposed construction, reconfiguration, or closure of nearby government facilities or amenities such as schools, parks, roadways and traffic signals
22. Existing or proposed government requirements affecting the Property (i) that tall grass, brush or other vegetation be cleared; (ii) that restrict tree (or other landscaping) planting, removal or cutting, or (iii) that flammable materials be removed

Explanation:

WATER-RELATED ISSUES:

ARE YOU (SELLER) AWARE OF..

- 23. Standing water, flooding, pumps, underground water, or water-related soil settling or slippage on or affecting the Property
24. Rivers, streams, flood channels, underground springs, high water table, floods or tides on or affecting the Property

Explanation:

UTILITIES AND SERVICES:

ARE YOU (SELLER) AWARE OF..

- 25. Whether any of the following utilities or services are available ON the Property
If yes, check which ones: water, sewer, septic, sanitation, teach lines, water, gas, electric, telephone, cable, other
If no, are you aware of the distance such utilities or services are from the Property?

Explanation:

LANDSCAPING, AGRICULTURE, STRUCTURES OR OTHER IMPROVEMENTS:

ARE YOU (SELLER) AWARE OF..

- 26. Diseases or infestations affecting trees, plants or vegetation on or near the Property
27. Diseases, infestation or other reason affecting the production of any agricultural trees or crops on the Property
28. Operational sprinklers or irrigation systems on the Property
If yes, are they automatic or manually operated.
29. Any structures or improvements (such as pad, foundations, or shelter)

Explanation:

NEIGHBORHOOD:

ARE YOU (SELLER) AWARE OF..

- 30. Neighborhood noise, nuisance or other problems from sources such as, but not limited to, the following: neighbors, livestock, wildlife, insects or pests, traffic, parking congestion, airplanes, trains, light rail, subway, trucks, freeways, buses, schools, parks, refuse storage or landfill processing, agricultural operations, business, odor, recreational facilities, restaurants, entertainment complexes or facilities, parade, sporting events, fairs, neighborhood parties, litter, construction, air conditioning equipment, air compressors, generators, pool equipment or appliances, or wildlife

Explanation:

Buyer's Initials

[Handwritten initials]

Seller's Initials

[Handwritten initials]

VLQ REVISED 11/12 (PAGE 2 OF 4)

SELLER VACANT LAND QUESTIONNAIRE (VLQ PAGE 2 OF 4)

Produced with eForm® by eLogix 18070 Filmore Mile Road, Piner, Michigan 48063 www.eLogix.com

City of Beaumont



COMMON INTEREST CONDOMINIUMS AND DEVELOPMENTS:

ARE YOU (SELLER) AWARE OF...

- 31. Any Homeowner or Property Owner Association (OA) governing the Property, or any pending or proposed dues increases, special assessments, rules changes, insurance, availability issues or threatened or pending litigation by or against the OA affecting the Property

Explanation:

TITLE, OWNERSHIP AND LEGAL CLAIMS:

ARE YOU (SELLER) AWARE OF...

- 32. Any other person or entity on title other than Seller(s) signing this form
33. Leases, options or claims affecting or relating to title or use of the Property
34. Any other person or entity other than Seller(s) signing this form with a legal claim to oil, mineral, gas or water rights
35. Past, present, pending or threatened lawsuits, mediations, arbitrations, tax liens, abatement items, mechanics' liens, notice of default, bankruptcy or other court filings, or government hearings affecting or relating to the Property, OA or neighborhood

Explanation:

DISASTER RELIEF, INSURANCE OR CIVIL SETTLEMENT:

ARE YOU (SELLER) AWARE OF...

- 36. Financial relief or assistance, insurance or settlement, sought or received, from any federal, state, local or private agency, insurer or private party, by past or present owners of the Property, due to any actual or alleged damage to the Property arising from a flood, earthquake, fire, other disaster, or occurrence or defect, whether or not any money received was actually used to correct damage

Explanation:

OTHER:

ARE YOU (SELLER) AWARE OF...

- 37. Reports, inspections, disclosures, warranties, maintenance recommendations, estimates, studies, surveys or other documents, pertaining to the condition of the Property or easements, encroachments, boundary disputes or environmental conditions affecting the Property
38. Department of Real Estate Public Report, or subdivision map
39. An Order from a government health official identifying the Property as being contaminated by methamphetamines. (If yes, attach a copy of the Order.)
40. The release of an illegal controlled substance on or beneath the Property.
41. Whether the Property is located in or adjacent to an "industrial use" zone
42. Whether the Property is affected by a nuisance created by an "industrial use" zone
43. Whether the Property is located within 1 mile of a former federal or state ordnance location
44. Whether the Property is a condominium or located in a planned unit development or other common interest subdivision
45. Insurance claims affecting the Property within the past 5 years
46. Matters affecting title of the Property.
47. Any past or present known material facts or other significant items affecting the value or desirability of the Property not otherwise disclosed to Buyer

Explanation:

VI. (IF CHECKED) ADDITIONAL COMMENTS: The attached addendum contains an explanation or additional comments in response to specific questions answered "yes" above. Refer to line and question number in explanation.

Buyer's Initials [Signature]

Seller's Initials [Signature]



Property Address: Vacant Land APN 417-110-018 ; SWC Fourth Street/Vista Avenue, City of Beaumont, CA 92221 Date: February 14, 2019

Seller represents that Seller has provided the answers and, if any, explanations and comments on this Form and any attached addenda and that such information is true and correct to the best of Seller's knowledge as of the date signed by Seller. Seller acknowledges (i) Seller's obligation to disclose information requested by this Form is independent from any duty of disclosure that a real estate licensee may have in this transaction, and (ii) nothing that any such real estate licensee does or says to Seller relieves Seller from his/her own duty of disclosure.

Date 2/14/19 Date 2/14/19
SELLER [Signature] SELLER [Signature]
By David P. Milecki By David P. Milecki
Print name V4B LLC, a California Limited Liability Company Print name David P. Milecki, single member
Title Single Member Title Single Member

By signing below, Buyer acknowledges that Buyer has read, understands and has received a copy of this Seller Vacant Land Questionnaire form.

Date 5/13/2019 Date 5/13/2019
BUYER [Signature] BUYER [Signature]
By Todd Parton By Todd Parton
Print name City of Beaumont, a municipal corporation, its manager Print name Todd Parton, City Manager
Title City Manager Title City Manager

© 2009, 2012, California Association of REALTORS®, Inc. United States copyright law (Title 17 U.S. Code) forbids the unauthorized distribution, display and reproduction of this form, or any portion thereof, by photocopy machine or any other means, including facsimile or computerized formats.
THIS FORM HAS BEEN APPROVED BY THE CALIFORNIA ASSOCIATION OF REALTORS® (C.A.R.), NO REPRESENTATION IS MADE AS TO THE LEGAL VALIDITY OR ACCURACY OF ANY PROVISION IN ANY SPECIFIC TRANSACTION, A REAL ESTATE BROKER IS THE PERSON QUALIFIED TO ADVISE ON REAL ESTATE TRANSACTIONS. IF YOU DESIRE LEGAL OR TAX ADVICE, CONSULT AN APPROPRIATE PROFESSIONAL.
This form is made available to real estate professionals through an agreement with or purchase from the California Association of REALTORS®. It is not intended to identify the user as a REALTOR®, REALTOR® is a registered collective membership mark which may be used only by members of the NATIONAL ASSOCIATION OF REALTORS® who subscribe to its Code of Ethics.

Published and Distributed by:
REAL ESTATE BUSINESS SERVICES, INC.
228 South Virgil Avenue, Los Angeles, California 90020



Staff Report

TO: Mayor and City Council Members

FROM: Melana Taylor, Director of Finance

DATE: May 21, 2019

SUBJECT: Fiscal Year 2019-20 Draft City-Wide Budget and Fiscal Years 2019-2020 through 2023-2024 Listing of Capital Improvement Plan Projects for Review

Background and Analysis:

On February 2, 2019, City Council held a workshop which included direction to City staff regarding the FY19-20 budget. On May 7, 2019, a draft of the General Fund budget was presented to Council with an over-budget net of approximately \$465,000.

The draft City-wide budget has been developed and is presented in the following manner:

1. General Fund – Zero net balanced budget with \$234,161 contingency.
2. Special Revenue Funds – Utilization of available funds for appropriate projects. Net activity for some funds will reflect a negative due to funds being available from prior years being utilized in the FY19-20 budget year.
3. Capital Funds – Government asset reporting and construction projects as well as development impact fee segregation and tracking.
4. Wastewater Funds – Segregate the operations, development impact fees, construction, bond funds utilized, and debt service payments for the wastewater enterprise.
5. Transit Funds – Segregate the operations, GASB 68 effects, capital grants management and capital assets for the Transit enterprise. Final budget will agree to the SRTP accepted by RCTC.
6. Debt Funds – Segregate general debt service, Community Facilities District debt, Beaumont Financing Authority debt and the Beaumont Public Improvement Authority debt.

The individual line item detail is subject to change as the final review of the City-wide budget is reviewed by staff. The Capital Improvement Plan of 2019/2020 through 2023/2024 has been drafted, however, the available source of funds for those projects have not all been identified and assigned. Based on funding availability, some will be deferred or re-organized.

Fiscal Impact:

None impact at this time.

Finance Director Review:



Recommendation:

1. Receive and file.

City Manager Review:



Attachments:

- A. Summarized draft City-wide budget for fiscal year 2019-2020
- B. Listing of Capital Improvement Plan projects for fiscal years 2019-2020 through 2023-2024
- C. Report of available cash for funding of projects through fiscal year 2019-2020

Attachment A

Summarized Draft of City-Wide budget for Fiscal Year 19/20

2016-2017 Total Budget	2016-2017 Total Activity	2017-2018 Total Budget	2017-2018 Total Activity	2018-2019 Total Budget	2018-2019 UNADJUSTED YTD Activity	2019-2020 DRAFT BUDGET
---------------------------	-----------------------------	---------------------------	-----------------------------	---------------------------	---	---------------------------

GENERAL FUND

REVENUES

40 - TAXES	14,816,600	16,169,475	16,183,810	17,720,669	16,980,867	11,891,392	18,233,045
41 - LICENSES	210,000	231,688	210,000	242,634	212,100	125,536	214,221
42 - PERMITS	2,552,000	4,037,282	3,723,000	4,544,519	5,397,170	4,436,505	5,167,885
45 - INTERGOVERNMENTAL	17,500	21,514	7,288	7,288	21,288	29,319	21,288
47 - CHARGES FOR SERVICE	5,079,967	6,934,989	7,457,000	8,491,817	7,702,800	7,113,243	2,852,950
50 - FINES AND FORFEITURES	120,000	128,005	148,000	114,572	110,000	81,248	133,850
53 - COST RECOVERY	15,000	426,733	285,000	344,845	-	454,676	125,000
54 - MISCELLANEOUS REVENUES	60,000	3,079,683	26,500	51,446	22,500	17,725	22,500
58 - OTHER FINANCING SOURCES	15,000	165,001	-	5,342	-	28,129	5,000
65 - OPERATING COSTS	-	3,182	-	4,632	-	-	-
78 - CAPITAL OUTLAY	-	-	-	586,947	-	-	-
80 - DEBT SERVICE	-	316,834	-	457,728	-	-	-
90 - TRANSFERS	5,825,500	6,117,785	5,191,400	4,299,392	5,132,745	111,919	5,627,300

DEPARTMENT EXPENSES

Department: 1050 - CITY COUNCIL

60 - PERSONNEL SERVICES	52,543	29,074	27,773	17,249	26,731	24,205.60	27,153
65 - OPERATING COSTS	86,600	18,463	21,678	21,741	52,600	13,105.75	19,750

Department: 1150 - CITY CLERK

60 - PERSONNEL SERVICES	128,400	110,388	108,812	114,176	119,396	98,231.61	157,201
65 - OPERATING COSTS	59,645	58,831	35,050	31,655	20,670	11,991.95	17,305

Department: 1200 - ADMINISTRATION

60 - PERSONNEL SERVICES	1,425,149	1,191,981	1,667,966	1,924,806	1,302,184	1,070,282.48	1,284,109
65 - OPERATING COSTS	560,800	430,351	679,813	636,727	(375,590)	-183,395.58	(240,285)
70 - CAPITAL IMPROVEMENTS	-	42,179	21,000	(280,391)	-	-	-
77 - CONTINGENCY	258,284	-	71,620	-	150,433	30,000.00	234,161

Department: 1225 - FINANCE AND BUDGETING

60 - PERSONNEL SERVICES	-	-	-	-	768,519	559,409.13	862,714
65 - OPERATING COSTS	-	-	-	-	153,790	139,824.26	103,125

Department: 1230 - I.T.

60 - PERSONNEL SERVICES	-	-	-	-	172,553	137,300.48	388,967
65 - OPERATING COSTS	-	-	-	-	701,455	508,072.47	743,075
70 - CAPITAL IMPROVEMENTS	-	-	-	-	287,750	141,138.91	-

Department: 1240 - RISK AND HUMAN RESOURCES

60 - PERSONNEL SERVICES	-	-	-	-	370,048	312,731.71	435,507
65 - OPERATING COSTS	-	-	-	-	982,970	962,203.85	1,201,602

Department: 1300 - LEGAL

65 - OPERATING COSTS	2,300,000	3,400,901	1,495,045	1,581,715	750,000	793,862.42	750,000
----------------------	-----------	-----------	-----------	-----------	---------	------------	---------

Department: 1350 - COMMUNITY DEVELOPMENT

60 - PERSONNEL SERVICES	405,735	378,134	284,643	255,364	365,952	309,975.79	374,203
65 - OPERATING COSTS	521,079	179,522	240,450	129,206	54,359	35,070.49	150,407
70 - CAPITAL IMPROVEMENTS	15,000	3,375	2,000	-	-	-	-

Department: 1550 - COMMUNITY SERVICES

60 - PERSONNEL SERVICES	455,667	423,154	521,491	494,386	502,539	389,751.95	671,509
65 - OPERATING COSTS	172,550	139,451	295,060	276,846	56,276	146,108.54	158,910
70 - CAPITAL IMPROVEMENTS	-	-	-	-	-	-	12,000

Department: 2000 - ANIMAL CONTROL

60 - PERSONNEL SERVICES	417,503	440,965	455,370	469,759	236,987	203,738.68	238,888
65 - OPERATING COSTS	202,965	110,485	120,130	154,740	66,023	56,445.01	79,316
70 - CAPITAL IMPROVEMENTS	-	-	35,000	-	8,800	8,744.76	-

Department: 2030 - COMMUNITY ENHANCEMENT

60 - PERSONNEL SERVICES	101,020	80,022	127,550	99,542	201,950	157,507.38	235,309
65 - OPERATING COSTS	-	58,116	59,785	52,221	43,898	14,209.98	45,097

Department: 2040 - PUBLIC SAFETY - OES

65 - OPERATING COSTS	-	2,818	7,000	7,656	7,000	2,803.25	6,000
----------------------	---	-------	-------	-------	-------	----------	-------

Department: 2050 - POLICE

60 - PERSONNEL SERVICES	7,064,286	6,782,521	7,608,451	6,907,421	8,369,538	6,728,787.15	9,091,500
65 - OPERATING COSTS	1,338,862	1,264,455	1,519,283	1,260,408	678,300	679,503.92	811,459
70 - CAPITAL IMPROVEMENTS	342,520	223,632	300,000	15,222	246,688	43,208.80	196,688

Department: 2080 - K-9

65 - OPERATING COSTS	-	5,198	6,650	5,313	3,600	4,531.13	5,900
----------------------	---	-------	-------	-------	-------	----------	-------

Department: 2090 - POLICE SUPPORT

60 - PERSONNEL SERVICES	1,254,978	1,227,568	1,511,873	1,333,928	1,681,803	1,326,366.32	1,679,736
65 - OPERATING COSTS	-	13,162	830	2,431	5,020	5,250.77	17,215

Department: 2100 - FIRE

65 - OPERATING COSTS	2,753,796	2,483,542	2,868,400	2,698,288	4,208,130	1,496,467.98	4,420,400
----------------------	-----------	-----------	-----------	-----------	-----------	--------------	-----------

Department: 2150 - BUILDING AND SAFETY

60 - PERSONNEL SERVICES	354,707	375,486	457,120	452,119	465,723	400,994.57	618,179
-------------------------	---------	---------	---------	---------	---------	------------	---------

	2016-2017 Total Budget	2016-2017 Total Activity	2017-2018 Total Budget	2017-2018 Total Activity	2018-2019 Total Budget	2018-2019 UNADJUSTED YTD Activity	2019-2020 DRAFT BUDGET
65 - OPERATING COSTS	275,980	282,075	395,180	527,498	1,012,015	811,101.64	674,555
70 - CAPITAL IMPROVEMENTS	-	-	-	-	30,500	30,470.45	-
Department: 3100 - ENGINEERING AND PUBLIC WORKS							
60 - PERSONNEL SERVICES	243,503	271,945	514,420	539,109	433,566	352,418.34	724,320
65 - OPERATING COSTS	3,873,370	1,394,341	2,082,475	1,126,483	999,550	491,600.64	511,685
70 - CAPITAL IMPROVEMENTS	-	11,950	-	680	500	-	60,000
Department: 3150 - REFUSE							
65 - OPERATING COSTS	-	4,239,047	4,979,080	4,928,368	5,000,000	3,891,230.03	-
Department: 3250 - STREET MAINTENANCE							
60 - PERSONNEL SERVICES	196,184	195,947	322,795	336,585	475,729	403,411.01	532,023
65 - OPERATING COSTS	1,236,700	1,028,665	1,436,451	1,163,315	1,490,477	807,813.96	1,269,307
70 - CAPITAL IMPROVEMENTS	-	52	220,000	(89,771)	152,500	101,610.37	38,332
Department: 6000 - BUILDING MAINTENANCE							
65 - OPERATING COSTS	-	-	-	-	440,289	335,199.35	525,381
70 - CAPITAL IMPROVEMENTS	-	-	-	-	100,000	8,019.00	-
Department: 6050 - PARKS AND GROUNDS MAINT							
60 - PERSONNEL SERVICES	1,360,870	1,347,035	1,602,805	1,515,187	1,745,349	1,357,221.78	2,066,094
65 - OPERATING COSTS	502,050	436,578	1,007,625	709,352	949,935	650,525.63	1,049,211
70 - CAPITAL IMPROVEMENTS	145,000	1,151	50,000	4,037	52,200	177,918.14	93,950
Department: 6150 - CITY POOL							
60 - PERSONNEL SERVICES	38,682	25,029	40,735	57,008	76,304	30,884.44	32,381
65 - OPERATING COSTS	31,300	23,734	14,300	25,205	34,460	21,680.80	28,700
70 - CAPITAL IMPROVEMENTS	2,500	-	2,500	-	-	-	-
NET							

SPECIAL REVENUE FUNDS

Fund: 200 - HIGHWAY USERS TAX (Gas)							
Department: 0000 - NON-DEPARTMENTAL							
40 - TAXES	870,000	860,044	920,000	976,299	955,900	765,461.41	936,500
45 - INTERGOVERNMENTAL	-	-	260,000	270,588	360,000	-	-
54 - MISCELLANEOUS REVENUES	-	72,289	500	8,771	26,000	2,975.11	11,600
90 - TRANSFERS	(870,000)	(1,030,885)	(1,180,000)	(1,349,341)	(1,305,000)	-1,164,379.27	(948,000)
Fund: 201 - STATE - SB1 FUNDING							
Department: 0000 - NON-DEPARTMENTAL							
45 - INTERGOVERNMENTAL	-	-	-	-	-	651,253.16	845,000
54 - MISCELLANEOUS REVENUES	-	-	-	-	-	10,022.48	-
90 - TRANSFERS	-	-	-	-	-	263,368.43	(845,000)
Fund: 202 - SALES TAX - MEASURE A							
Department: 0000 - NON-DEPARTMENTAL							
40 - TAXES	-	-	-	-	-	709,981.66	1,078,700
54 - MISCELLANEOUS REVENUES	-	-	-	-	-	14,855.21	-
90 - TRANSFERS	-	-	-	-	-	541,888.79	(1,078,700)
Fund: 205 - MOTOR VEHICLE SUBVENTION (AB2766-AQMD)							
Department: 0000 - NON-DEPARTMENTAL							
45 - INTERGOVERNMENTAL	50,000	57,615	50,000	57,275	50,000	30,029.11	57,000
54 - MISCELLANEOUS REVENUES	-	19,488	-	6,406	4,000	7,847.42	-
90 - TRANSFERS	(10,000)	900	-	-	-	-	(30,000)
Fund: 210 - PUBLIC, EDUCATIONAL, GOVT (PEG)							
Department: 0000 - NON-DEPARTMENTAL							
40 - TAXES	25,000	42,907	25,000	25,902	52,520	30,216.46	30,000
54 - MISCELLANEOUS REVENUES	-	13,833	-	4,595	2,000	5,292.25	-
90 - TRANSFERS	-	-	-	-	-	-	(250,000)
Fund: 215 - GRANTS (REIMBURSABLE)							
Department: 0000 - NON-DEPARTMENTAL							
45 - INTERGOVERNMENTAL	425,000	740,801	-	203,883	10,190,000	97,954.40	175,000
60 - PERSONNEL SERVICES	-	4,683	-	-	-	-	-
65 - OPERATING COSTS	425,000	240,397	-	-	190,000	268	-
70 - CAPITAL IMPROVEMENTS	-	495,722	-	218,310	-	10,407.50	175,000
90 - TRANSFERS	-	-	-	14,427	(10,000,000)	-	-
Fund: 220 - CITIZEN OPTION PUBLIC SAFETY (COPS)							
Department: 0000 - NON-DEPARTMENTAL							
45 - INTERGOVERNMENTAL	100,000	100,000	100,000	157,154	100,000	107,080.13	100,000
47 - CHARGES FOR SERVICE	-	-	-	11,516	110,000	-	-
54 - MISCELLANEOUS REVENUES	-	16,972	-	6,107	2,400	6,082.98	-
60 - PERSONNEL SERVICES	-	1,304	-	1,889	-	-	-
65 - OPERATING COSTS	-	7,283	-	25,449	-	19,767.67	283,300
70 - CAPITAL IMPROVEMENTS	-	4,609	-	27,117	125,000	-	-
90 - TRANSFERS	(100,000)	(7,917)	(100,000)	(32,219)	(80,000)	-60,000.00	50,000
Fund: 225 - ASSET SEIZURES (STATE)							
Department: 0000 - NON-DEPARTMENTAL							

	2016-2017 Total Budget	2016-2017 Total Activity	2017-2018 Total Budget	2017-2018 Total Activity	2018-2019 Total Budget	2018-2019 UNADJUSTED YTD Activity	2019-2020 DRAFT BUDGET
47 - CHARGES FOR SERVICE	-	14,804	-	1,698	-	3,481.23	-
54 - MISCELLANEOUS REVENUES	-	20,412	-	5,505	2,400	7,067.18	-
65 - OPERATING COSTS	-	7,079	-	-	-	36	-
70 - CAPITAL IMPROVEMENTS	-	-	-	-	275,000	2,895.00	-
90 - TRANSFERS	-	-	-	17,973	-	-	-
Fund: 230 - ASSET SEIZURES (FEDERAL)							
Department: 0000 - NON-DEPARTMENTAL							
47 - CHARGES FOR SERVICE	-	-	-	-	-	3,075.00	-
54 - MISCELLANEOUS REVENUES	-	14,416	-	4,015	2,000	4,015.75	-
70 - CAPITAL IMPROVEMENTS	-	(0)	-	-	200,000	-	200,000
90 - TRANSFERS	-	-	-	(17,973)	-	-	-
Fund: 240 - OTHER RESTRICTED FUNDS							
Department: 0000 - NON-DEPARTMENTAL							
45 - INTERGOVERNMENTAL	-	-	-	-	-	-	(10,000)
47 - CHARGES FOR SERVICE	-	248	-	-	-	-	-
65 - OPERATING COSTS	-	-	-	2,613	-	-	10,000
90 - TRANSFERS	-	-	-	27,231	-	-	8,000
Department: 2080 - K-9							
58 - OTHER FINANCING SOURCES	-	-	-	7,549	7,000	4,993.00	7,000
65 - OPERATING COSTS	-	-	-	46	2,000	-	20,000
70 - CAPITAL IMPROVEMENTS	-	-	-	-	30,000	-	-
Department: 2300 - SHOP WITH A COP/HERO							
58 - OTHER FINANCING SOURCES	-	-	-	4,422	4,000	6,320.00	5,000
65 - OPERATING COSTS	-	-	-	3,537	4,000	5,039.42	5,000
Department: 2310 - EXPLORER PROGRAM							
58 - OTHER FINANCING SOURCES	-	-	-	832	500	275	500
65 - OPERATING COSTS	-	-	-	1,589	500	4,509.36	500
Department: 2320 - AMR EMERGENCY SUPPORT							
58 - OTHER FINANCING SOURCES	-	-	-	38,827	10,000	-	8,000
65 - OPERATING COSTS	-	-	-	(2,475)	10,000	5,280.76	13,600
Department: 2330 - SB1186 CASP FEES (BUS LICENSE)							
41 - LICENSES	-	-	-	4,559	-	2,736.00	-
65 - OPERATING COSTS	-	-	-	1,000	-	-	-
Department: 2350 - MILITARY BANNER PROGRAM							
58 - OTHER FINANCING SOURCES	-	-	-	-	-	2,270.00	(1,000)
Department: 2390 - OTHER PUBLIC SAFETY RESTRICTED							
58 - OTHER FINANCING SOURCES	-	733	-	12,243	-	10	-
Fund: 250 - COMMUNITY FAC DISTRICT (CFD) - ADMIN							
Department: 0000 - NON-DEPARTMENTAL							
54 - MISCELLANEOUS REVENUES	15,000	-	-	112,786	-	173,149.19	-
58 - OTHER FINANCING SOURCES	24,462,596	4,358,001	4,172,203	4,633,401	1,391,290	1,375.00	1,543,105
65 - OPERATING COSTS	1,000,000	266,226	-	504,192	331,628	214,822.13	316,000
80 - DEBT SERVICE	-	-	-	175,230	-	55,425.10	-
90 - TRANSFERS	(4,100,500)	(2,050,250)	(4,170,000)	(4,379,389)	(1,059,662)	-39,625.10	(890,465)
Fund: 255 - COMMUNITY FAC DISTRICT (CFD) - MAINT SVC							
Department: 0000 - NON-DEPARTMENTAL							
58 - OTHER FINANCING SOURCES	-	-	-	-	3,268,083	1,942,782.49	3,711,235
90 - TRANSFERS	-	-	-	-	(3,268,083)	-	(3,716,835)
Fund: 260 - COMMUNITY FAC DISTRICT (CFD) - PUBLIC SFTY							
Department: 0000 - NON-DEPARTMENTAL							
58 - OTHER FINANCING SOURCES	-	-	-	-	40,387	100,521.90	291,863
90 - TRANSFERS	-	-	-	-	-	-	(100,000)
Fund: 265 - COMMUNITY FAC DISTRICT (CFD) - PUBLIC FAC							
Department: 0000 - NON-DEPARTMENTAL							
58 - OTHER FINANCING SOURCES	-	-	-	-	-	-	860,781
NET							<u>825,884</u>

CAPITAL FUNDS

Fund: 150 - GOVERNMENTAL CAPITAL ASSETS							
Department: 0000 - NON-DEPARTMENTAL							
65 - OPERATING COSTS	-	-	-	5,018,700	-	-	-
Fund: 500 - GENERAL CAPITAL PROJECTS							
Department: 0000 - NON-DEPARTMENTAL							
45 - INTERGOVERNMENTAL	-	204,000	-	5,447,605	12,000,000	2,738,075.23	-
54 - MISCELLANEOUS REVENUES	-	-	-	85,868	-	3,420,625.61	-
65 - OPERATING COSTS	-	689,874	-	6,163,168	-	1,770,035.17	-
70 - CAPITAL IMPROVEMENTS	-	632,323	-	8,374,045	23,014,000	5,761,094.78	2,173,700
90 - TRANSFERS	-	7,745,800	-	9,003,740	11,014,000	396,196.46	2,173,700
Fund: 505 - EQUIPMENT REPLACEMENT							
Department: 0000 - NON-DEPARTMENTAL							

	2016-2017 Total Budget	2016-2017 Total Activity	2017-2018 Total Budget	2017-2018 Total Activity	2018-2019 Total Budget	2018-2019 UNADJUSTED YTD Activity	2019-2020 DRAFT BUDGET
58 - OTHER FINANCING SOURCES	-	1,000	-	-	-	-	-
70 - CAPITAL IMPROVEMENTS	-	49,170	-	-	-	-	-
Fund: 510 - COMMUNITY FACILITIES DISTRICT (CFD) - CAPITAL FUND							
Department: 0000 - NON-DEPARTMENTAL							
54 - MISCELLANEOUS REVENUES	-	37,021	-	231,493	-	1,235,209.10	330,400
58 - OTHER FINANCING SOURCES	-	4,402,813	1,008,216	4,329,253	-	-	-
65 - OPERATING COSTS	-	698,440	-	-	-	2,066,020.57	3,000
70 - CAPITAL IMPROVEMENTS	-	-	-	-	-	14,729,560.29	2,666,100
78 - CAPITAL OUTLAY	-	-	-	-	-	2,154,738.65	-
80 - DEBT SERVICE	-	-	-	3,165,112	-	-	-
90 - TRANSFERS	-	(5,068,668)	-	655,681	-	13,748,251.94	-
95 - SPECIAL ITEMS	-	-	-	-	-	8,637,028.95	-
Fund: 550 - DEVELOPMENT IMPACT (MITIGATION)							
Department: 0000 - NON-DEPARTMENTAL							
90 - TRANSFERS	-	255,222	-	-	(34,000)	-	-
Fund: 552 - BASIC SERVICES DEVELOPMENT							
Department: 0000 - NON-DEPARTMENTAL							
47 - CHARGES FOR SERVICE	143,000	319,000	175,000	266,528	167,448	337,289.16	189,873
65 - OPERATING COSTS	-	-	-	2,250	-	-	-
70 - CAPITAL IMPROVEMENTS	-	-	-	3,000	-	50	-
90 - TRANSFERS	-	-	-	(261,278)	-	-200,000.00	-
Fund: 554 - GENERAL PLAN DEVELOPMENT							
Department: 0000 - NON-DEPARTMENTAL							
47 - CHARGES FOR SERVICE	14,474	68,254	17,550	32,966	20,000	161,573.85	22,500
70 - CAPITAL IMPROVEMENTS	-	-	-	300	-	32	-
90 - TRANSFERS	-	(361,987)	(100,000)	(32,666)	-	-151,423.85	-
Fund: 555 - RECREATIONAL FACILITIES DEVELOPMENT							
Department: 0000 - NON-DEPARTMENTAL							
47 - CHARGES FOR SERVICE	-	-	-	264,917	286,196	395,062.58	324,522
90 - TRANSFERS	-	-	-	(264,917)	-	-	-
Fund: 556 - TRAFFIC IMPACT DEVELOPMENT							
Department: 0000 - NON-DEPARTMENTAL							
47 - CHARGES FOR SERVICE	52,126	150,697	63,800	169,571	108,284	265,305.39	122,076
70 - CAPITAL IMPROVEMENTS	-	-	-	1,081	-	206	-
90 - TRANSFERS	-	-	-	(168,491)	-	-	-
Fund: 558 - RAILROAD CROSSING DEVELOPMENT							
Department: 0000 - NON-DEPARTMENTAL							
47 - CHARGES FOR SERVICE	58,940	170,394	72,100	183,600	116,368	299,594.16	131,188
70 - CAPITAL IMPROVEMENTS	-	-	-	1,222	-	221	-
90 - TRANSFERS	-	-	-	(182,379)	-	-	-
Fund: 559 - POLICE FACILITIES DEVELOPMENT							
Department: 0000 - NON-DEPARTMENTAL							
47 - CHARGES FOR SERVICE	-	-	-	190,054	196,412	395,477.29	222,714
70 - CAPITAL IMPROVEMENTS	-	-	-	-	-	59	-
90 - TRANSFERS	-	-	-	(190,054)	-	-	-
Fund: 560 - FIRE STATION DEVELOPMENT							
Department: 0000 - NON-DEPARTMENTAL							
47 - CHARGES FOR SERVICE	129,608	271,928	188,700	351,198	227,472	662,071.70	257,935
70 - CAPITAL IMPROVEMENTS	-	-	-	3,195	-	113	-
90 - TRANSFERS	-	-	-	(348,004)	-	-	-
Fund: 562 - ROAD AND BRIDGE DEVELOPMENT							
Department: 0000 - NON-DEPARTMENTAL							
47 - CHARGES FOR SERVICE	3,010,581	7,645,898	3,853,500	3,720,086	985,884	2,337,264.04	1,111,450
65 - OPERATING COSTS	-	-	-	2,000,000	-	-	-
70 - CAPITAL IMPROVEMENTS	-	-	1,000,000	65,678	-	2,212.22	-
90 - TRANSFERS	-	(7,100,000)	-	(1,654,408)	(500,000)	-	-
Fund: 564 - RECYCLED WATER DEVELOPMENT							
Department: 0000 - NON-DEPARTMENTAL							
47 - CHARGES FOR SERVICE	225,765	533,389	277,000	531,198	314,656	585,618.88	353,988
70 - CAPITAL IMPROVEMENTS	-	-	-	4,720	-	-	-
90 - TRANSFERS	-	-	-	(526,478)	(50,000)	-	-
Fund: 566 - EMERGENCY PREPAREDNESS							
Department: 0000 - NON-DEPARTMENTAL							
47 - CHARGES FOR SERVICE	209,439	624,950	250,000	442,166	291,852	924,741.40	353,988
70 - CAPITAL IMPROVEMENTS	-	-	-	4,378	-	141	-
90 - TRANSFERS	-	-	-	(437,788)	-	-	-
Fund: 567 - COMMUNITY PARK DEVELOPMENT							
Department: 0000 - NON-DEPARTMENTAL							
47 - CHARGES FOR SERVICE	-	-	-	458,237	939,828	1,449,421.92	1,061,707
70 - CAPITAL IMPROVEMENTS	-	-	-	-	-	197,363.88	-
90 - TRANSFERS	-	-	-	(458,237)	-	-	-

	2016-2017 Total Budget	2016-2017 Total Activity	2017-2018 Total Budget	2017-2018 Total Activity	2018-2019 Total Budget	2018-2019 UNADJUSTED YTD Activity	2019-2020 DRAFT BUDGET
Fund: 568 - REGIONAL PARK DEVELOPMENT							
Department: 0000 - NON-DEPARTMENTAL							
47 - CHARGES FOR SERVICE	246,683	540,829	264,000	154,696	-	-	-
70 - CAPITAL IMPROVEMENTS	-	-	-	5,543	-	-	-
90 - TRANSFERS	-	-	-	(149,153)	-	-	-
Fund: 569 - NEIGHBORHOOD PARK DEVELOPMENT							
Department: 0000 - NON-DEPARTMENTAL							
47 - CHARGES FOR SERVICE	-	-	-	554,542	1,137,348	1,754,042.22	1,284,844
70 - CAPITAL IMPROVEMENTS	-	-	-	-	-	238,843.08	-
90 - TRANSFERS	-	-	-	(554,542)	-	-	-
NET							<u>3,098,085</u>

WASTEWATER FUNDS

Fund: 700 - WASTEWATER FUND							
Department: 0000 - NON-DEPARTMENTAL							
50 - FINES AND FORFEITURES	-	-	-	-	9,000	9,000.00	-
53 - COST RECOVERY	-	1,741	4,700	11,312	-	-	-
54 - MISCELLANEOUS REVENUES	1,900	-	-	-	33,000	70,544.13	10,000
56 - PROPRIETARY REVENUES	7,083,700	7,423,174	7,928,500	8,046,176	8,820,774	7,311,055.49	9,862,625
58 - OTHER FINANCING SOURCES	-	-	-	-	1,466	1,465.88	-
60 - PERSONNEL SERVICES	-	470	-	15,423	-	-	-
90 - TRANSFERS	-	(1,270,846)	-	(3,855,106)	-	-100,000.00	(7,082,326)
Department: 4050 - SEWER OPERATIONS							
60 - PERSONNEL SERVICES	483,036	68,937	272,723	288,324	932,764	657,096.99	1,895,369
65 - OPERATING COSTS	3,638,250	4,658,376	3,890,000	3,278,621	4,168,360	2,619,702.93	2,922,998
70 - CAPITAL IMPROVEMENTS	-	6,339	-	-	89,750	69,587.79	10,000
Fund: 705 - WASTEWATER DEVELOPMENT							
Department: 0000 - NON-DEPARTMENTAL							
54 - MISCELLANEOUS REVENUES	-	-	-	-	-	-	15,000
90 - TRANSFERS	-	-	(4,050,000)	(3,884,726)	(300,000)	-	(480,000)
Department: 6005 - CAPACITY FEES							
47 - CHARGES FOR SERVICE	955,000	2,162,834	1,400,000	3,053,672	2,050,000	2,987,272.90	2,398,500
70 - CAPITAL IMPROVEMENTS	-	-	-	30,750	-	-	-
Department: 6015 - UPPER POTRERO							
47 - CHARGES FOR SERVICE	-	-	-	1,953	-	-	-
Department: 6020 - LOWER POTRERO							
47 - CHARGES FOR SERVICE	-	-	-	42,461	-	29,157.48	24,600
Department: 6025 - SAN TIMOTEO NO-2 (LOWER OAK VALLEY)							
47 - CHARGES FOR SERVICE	-	-	-	-	-	-	-
Department: 6026 - SAN TIMOTEO NO-3 (BEAUMONT MESA)							
47 - CHARGES FOR SERVICE	-	65,640	-	31,210	-	11,129.24	12,097
Department: 6030 - SOUTHERN TRUNK MAIN							
47 - CHARGES FOR SERVICE	1,533	3,426	-	7,958	-	6,242.35	6,760
Department: 6060 - 4TH STREET EXTENSION							
47 - CHARGES FOR SERVICE	-	101,169	-	-	-	-	-
Department: 6065 - WILLOW SPRINGS							
47 - CHARGES FOR SERVICE	-	17,725	-	-	-	55,006.06	-
Department: 6070 - GATEWAY SEWER							
47 - CHARGES FOR SERVICE	-	-	-	-	-	-	-
Department: 6075 - POTRERO SEWER							
47 - CHARGES FOR SERVICE	-	-	-	-	-	-	-
Fund: 710 - WASTEWATER CAPITAL PROJECTS							
Department: 0000 - NON-DEPARTMENTAL							
54 - MISCELLANEOUS REVENUES	-	-	-	778,223	-	764,808.67	(3,868,688)
58 - OTHER FINANCING SOURCES	-	-	-	-	90,000,000	8,895,000.00	-
65 - OPERATING COSTS	-	7,498,936	4,050,000	10,160,556	3,150,000	1,475,677.87	-
70 - CAPITAL IMPROVEMENTS	3,977,000	(1,040,473)	400,000	(3,312,923)	87,200,000	22,683,977.67	2,693,638
80 - DEBT SERVICE	-	-	-	-	-	-	1,000,000
90 - TRANSFERS	-	1,270,846	5,250,000	11,233,326	350,000	2,944,885.19	7,562,326
NET							<u>(61,110)</u>

TRANSIT FUNDS

Fund: 750 - TRANSIT FUND							
Department: 0000 - NON-DEPARTMENTAL							
45 - INTERGOVERNMENTAL	2,308,307	2,238,488	2,403,840	2,328,523	2,498,881	2,055,705.91	2,752,129
53 - COST RECOVERY	-	-	-	316	-	-	-
54 - MISCELLANEOUS REVENUES	139	3,860	-	4,661	4,000	2,983.87	6,200
56 - PROPRIETARY REVENUES	243,493	219,522	267,093	233,860	218,979	153,628.86	-
58 - OTHER FINANCING SOURCES	-	-	-	6	-	4,168.75	-

	2016-2017 Total Budget	2016-2017 Total Activity	2017-2018 Total Budget	2017-2018 Total Activity	2018-2019 Total Budget	2018-2019 UNADJUSTED YTD Activity	2019-2020 DRAFT BUDGET
90 - TRANSFERS	-	-	-	(322)	-	-18,584.34	-
Department: 7000 - TRANSIT ADMINISTRATION							
60 - PERSONNEL SERVICES	425,498	465,689	564,168	482,419	506,263	417,642.11	405,028
65 - OPERATING COSTS	215,858	241,646	171,300	142,245	173,420	138,391.98	268,720
70 - CAPITAL IMPROVEMENTS	-	-	-	(44)	-	-	-
Department: 7100 - DIAL-A-RIDE							
60 - PERSONNEL SERVICES	147,266	158,107	161,687	211,590	165,294	155,127.24	185,582
65 - OPERATING COSTS	27,000	29,707	27,600	29,877	38,925	25,973.54	28,804
Department: 7200 - FIXED ROUTE							
60 - PERSONNEL SERVICES	859,082	772,564	907,065	687,137	875,618	564,442.68	851,553
65 - OPERATING COSTS	148,250	202,009	181,200	328,224	274,750	246,065.60	371,810
Department: 7300 - VEHICLE MAINTENANCE							
60 - PERSONNEL SERVICES	346,929	352,912	476,809	435,589	487,327	386,996.67	524,370
65 - OPERATING COSTS	30,325	(30,663)	(10,500)	(20,802)	(58,551)	1,229.12	20,974
Department: 7400 - ROUTE 120							
60 - PERSONNEL SERVICES	66,562	85,941	88,983	111,342	91,520	111,578.89	188,065
65 - OPERATING COSTS	41,160	35,891	33,300	31,378	23,225	65,463.11	58,800
Department: 7500 - ROUTE 136							
60 - PERSONNEL SERVICES	68,676	74,025	62,021	97,529	124,809	13,058.65	-
65 - OPERATING COSTS	13,400	4,476	6,800	30,881	1,500	2,541.06	-
Department: 7600 - ROUTE 125							
60 - PERSONNEL SERVICES	137,353	-	-	-	400	84,462.97	150,457
65 - OPERATING COSTS	23,320	-	-	-	17,360	34,913.38	37,800
Fund: 755 - TRANSIT GASB68 FUND							
Department: 0000 - NON-DEPARTMENTAL							
56 - PROPRIETARY REVENUES	-	-	-	97,864	-	-	100,000
60 - PERSONNEL SERVICES	-	-	-	97,864	-	-	100,000
Fund: 760 - TRANSIT CAPITAL PROJECTS							
Department: 0000 - NON-DEPARTMENTAL							
45 - INTERGOVERNMENTAL	-	492,449	-	115,404	-	714,771.63	-
54 - MISCELLANEOUS REVENUES	-	4,744	-	281	-	-	-
65 - OPERATING COSTS	-	582,719	-	518,763	-	9,513.84	-
70 - CAPITAL IMPROVEMENTS	-	14,271	-	14,221	-	565,897.33	-
NET							<u><u>(333,634)</u></u>

DEBT FUNDS

Fund: 300 - DEBT SERVICE							
Department: 0000 - NON-DEPARTMENTAL							
60 - PERSONNEL SERVICES	-	(276,613)	-	4,739,050	-	-	-
Fund: 840 - COMMUNITY FACILITIES DISTRICT (CFD)							
Department: 0000 - NON-DEPARTMENTAL							
54 - MISCELLANEOUS REVENUES	-	3,584	61,792	33,853	-	64,992.25	63,325
58 - OTHER FINANCING SOURCES	-	16,484,796	-	15,184,998	15,061,089	10,972,063.10	18,391,184
80 - DEBT SERVICE	-	-	(12,800,000)	(9,994,630)	(15,205,055)	10,839,479.95	(18,274,757)
90 - TRANSFERS	-	(16,029,314)	-	(27,861,325)	-	-16,803,591.11	-
Fund: 850 - BEAUMONT FINANCING AUTHORITY (BFA)							
Department: 0000 - NON-DEPARTMENTAL							
54 - MISCELLANEOUS REVENUES	-	97,249	-	153,120	-	188,669.08	225,000
58 - OTHER FINANCING SOURCES	-	10,178,797	19,054,000	7,185,340	7,628,361	7,724,900.52	7,655,650
80 - DEBT SERVICE	-	(32,245,020)	(19,054,000)	(120,964,877)	(7,628,361)	-7,715,612.06	(7,820,638)
90 - TRANSFERS	-	16,028,473	-	(8,708,825)	-	-37,582.73	-
Fund: 855 - BEAUMONT PUBLIC IMPROVEMENT AUTH							
Department: 0000 - NON-DEPARTMENTAL							
54 - MISCELLANEOUS REVENUES	-	-	-	-	-	151,356.07	-
58 - OTHER FINANCING SOURCES	-	-	-	-	-	803,951.95	-
65 - OPERATING COSTS	-	-	-	-	-	1,661,355.20	-
80 - DEBT SERVICE	-	-	-	-	-	794,969.15	-
90 - TRANSFERS	-	-	-	-	-	287,661.81	-
NET							<u><u>239,764</u></u>

Attachment B

Draft Listing of Capital Improvement Plan Projects for Fiscal years 2019-2020 through 2023-2024

Listing of Capital Improvement Plan projects for fiscal years 2019-2020 through 2023-2024:

Project	Potential Funding Source	FY19-20	FY20-21	FY21-22	FY22-23	FY23-24	Future
Council Chambers	PEG	273,000					
City Hall Plaza	Basic Svc DIF						18,000,000
2 nd St Ext Design	Road & Bridge DIF	100,000					
Penn Grade Sep Design	Road & Bridge DIF						1,000,000
California Grade Sep Design	Road & Bridge DIF						800,000
Oak Valley/I-10 Interchange Design	Road & Bridge DIF						500,000
1 st Street Widening	Road & Bridge DIF						
Beaumont Ave Signal Study	Road & Bridge DIF	15,000					
6 th /Xenia Signal Study	Road & Bridge DIF	5,000					
Beaumont Ave Signal Construction	Road & Bridge DIF		795,000				
6 th /Xenia Signal Construction	Road & Bridge DIF		795,000				
Police Annex	Public Safety DIF	30,000					
PD Server Room	Public Safety DIF						
Rehab Existing Fire Stations	CFD Public Safety			500,000	500,000		
Park/Right of Way Upgrades	CFD Capital Funding	300,000	200,000	200,000	200,000		850,000
CRC	CFD Capital Funding	75,000		100,000			
Annual Slurry Seal	Measure A SB1	1,000,000	1,000,000	1,000,000	1,000,000	1,000,000	
Annual Street Rehab	Measure A SB1	800,000	800,000	800,000	800,000	800,000	
Beaumont Ave Reconstruction	SB1	700,000					
Comprehensive Zoning Code	Grant	130,000	30,000				

Project	Potential Funding Source	FY19-20	FY20-21	FY21-22	FY22-23	FY23-24	Future
Pennsylvania Grade Sep Construction	Grant						34,000,000
California Grade Sep Construction	Grant						34,000,000
Oak Valley/I-10 Interchange Construction	Grant						65,000,000
CNG Station Construction	Transit Grant	1,700,000					
Rangel Park Improvement	CDBG	130,000					
Citywide Sidewalk Improvements	CDBG		130,000	130,000	130,000	130,000	
Pool	General Fund	25,000	50,000	20,000			
City Hall	General Fund						
Facility Roofs	General Fund	10,000	75,000	15,000	10,000	100,000	
Equipment Replacement	General Fund	92,000					
Housing Element Update	General Fund	40,000	50,000				
Storm Drain Facilities	General Fund						1,000,000
Storm Drain Master Plan	General Fund						500,000
Street Light Conversion to Solar	General Fund						1,500,000
Sewer Collection and Treatment	WW Ops WW DIF	800,000	1,677,000	1,727,000	1,889,000		
Seneca Springs L/S Construction	WW Ops WW DIF	800,000					
PLC Upgrades	WW Ops WW DIF	240,000					
CMOM	WW Ops WW DIF	100,000					
WQMP	WW Ops WW DIF	50,000					
WWTP Master Plan	WW Ops WW DIF	400,000					
WWWTP Permit	WW Ops WW DIF	100,000					
Mesa Force Main Prelim Design	WW Ops WW DIF	100,000					

Attachment C

Report of Available Cash for Funding Projects through Fiscal Year 2019- 2020

CITY OF BEAUMONT
 Funding Sources Available for Projects
 As of 5/14/19

	Avail Cash 5/14/19	Projected Activity FY19	Budget Activity FY20	Total Funding Available
201 SB 1	924,644.07	210,000.00	845,000.00	1,979,644.07
202 Measure A	1,266,725.66	328,000.00	1,078,700.00	2,673,425.66
505 Equipment Replacement	211,586.21	-	-	211,586.21
510 CFD Capital:				
2015C, IA 18 ***	853,148.87	3,200.00	16,400.00	872,748.87
2015D, IA 16 ***	1,813,572.23	6,800.00	34,000.00	1,854,372.23
550 DIF-Alley in Lieu	34,476.68	-	-	34,476.68
552 Basic Svc	899,882.62	52,000.00	189,873.00	1,141,755.62
555 Recreational Fac	552,035.45	98,000.00	324,522.00	974,557.45
556 Traffic Impact	1,138,023.15	36,000.00	1,220,763.00	2,394,786.15
558 RR Crossing	442,918.56	38,000.00	131,188.00	612,106.56
559 Police Fac	511,392.03	66,000.00	222,714.00	800,106.03
560 Fire Station	3,090,522.92	50,000.00	257,935.00	3,398,457.92
562 Road/Bridge	4,234,729.53	330,000.00	1,111,450.00	5,676,179.53
564 Recycled Water	2,139,502.40	100,000.00	353,988.00	2,593,490.40
567 Community Park	931,159.12	320,000.00	1,061,707.00	2,312,866.12
568 Regional Park	1,920,244.94	-	-	1,920,244.94
569 Neighborhood Park	1,126,857.47	390,000.00	1,284,844.00	2,801,701.47
705 WW DIF	3,261,036.68	600,000.00	1,976,957.00	5,837,993.68

*** Interest budgeted as if funds remain for entire FY20

Staff Report

TO: Mayor and City Council Members
FROM: Christina Taylor, Community Development Director
DATE: May 21, 2019
SUBJECT: General Plan Update Status Report

Background and Analysis:

The Beaumont 2040 Plan (the General Plan Update) is a comprehensive update of the City's General Plan and identifies major strategies and physical improvements for the City over the next 20 to 30 years. These strategies include revitalizing Sixth Street into a "downtown", transforming Beaumont Avenue and Sixth Street into mixed-use corridors, expanding jobs, expanding housing choices in the City with new affordable and market-rate single family homes and multi-family housing, constructing two new job centers along Highway 79 in the southern portion of the City, neighborhood enhancement strategies, and building new, environmentally sensitive neighborhoods on lands located immediately to the southwest of the City. To achieve this direction, the City will also need to ensure that the history and identity of the community is preserved, parks and recreational facilities are constructed, and a multimodal transportation system is developed.

Since the kick-off in 2017, the General Plan Update process has included community outreach, analysis of existing conditions, visioning and alternative plan considerations. Currently, the general plan policies are being written, traffic, air and noise models are being run, and the document is being drafted. The Downtown Specific Plan is being concurrently drafted. The Program EIR for these documents is also underway.

Attached for your information is a timeline showing what tasks have been completed, what are in progress and when the draft General Plan Update, Downtown Specific Plan and EIR will begin the public review and final approval process. It is anticipated, the draft documents will be available for public review beginning October 2019, with the Planning Commission hearing taking place in early 2020 and the City Council hearing in March 2020.

Fiscal Impact:

This update has no fiscal impact.

Finance Director Review: 

Recommendation:

1. Receive and file the General Plan Update status report.

City Manager Review:  _____

Attachments:

- A. General Plan Update Timeline

BEAUMONT PROJECT WORK PLAN

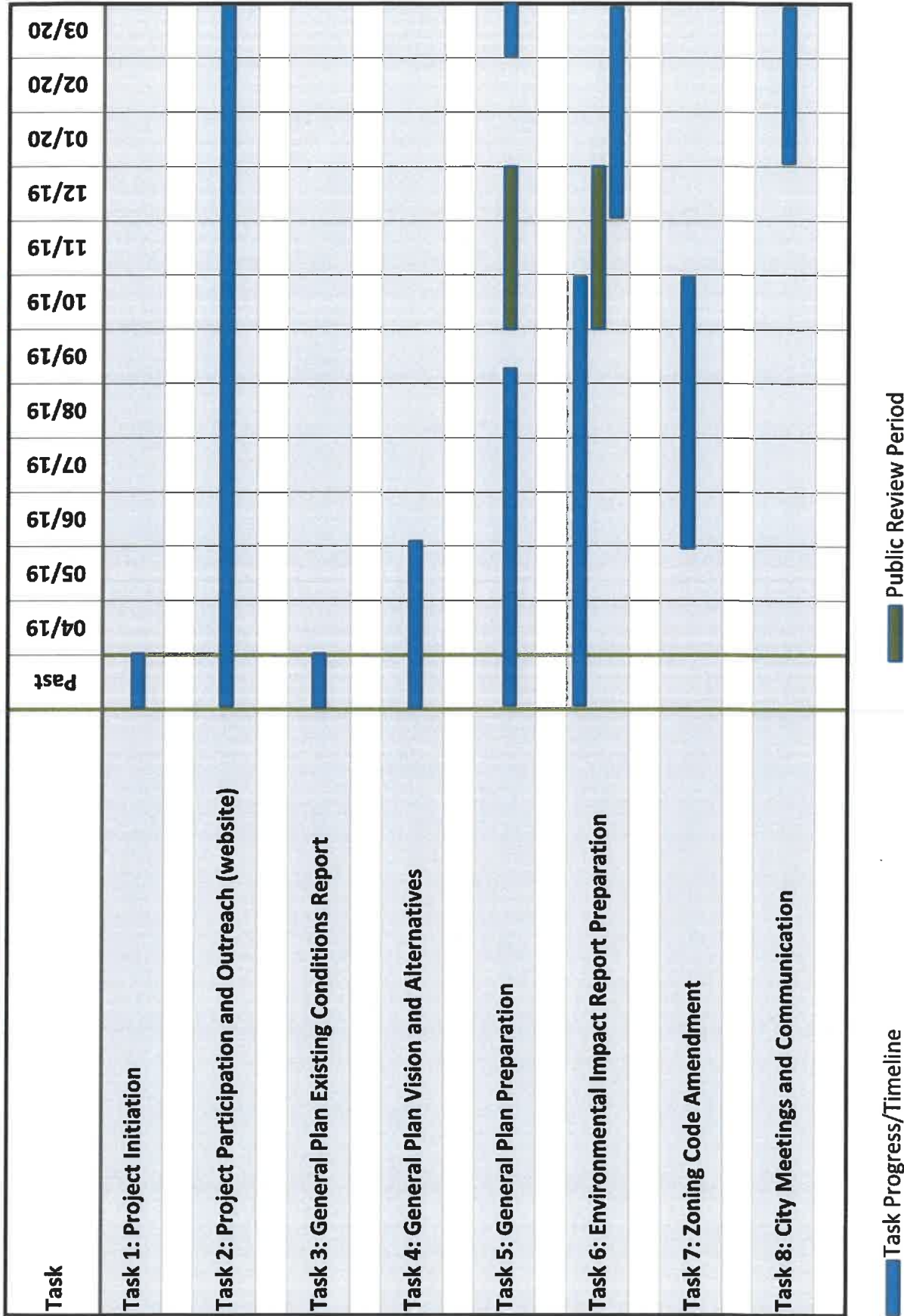

Staff Report

TO: Mayor and City Council Members
FROM: Melana Taylor, Finance Director
DATE: May 21, 2019
SUBJECT: Approval of Tyler Technologies Invoices Totaling \$88,146.00

Background and Analysis:

The City of Beaumont's purchasing ordinance requires City Council approval for purchases greater than \$25,000 for goods and services.

The City utilizes integrated financial software and is required to pay annual subscription and integration service fees to Tyler Technologies. On March 1, 2016, City Council approved the Software License and Services Agreement with Incode for the City-Wide Software System owned by Tyler Technologies for a term of seven years.

After implementation, an additional 6 licenses were required and an addendum to the agreement was added for the licensing at the original pricing per the contract for a term of five years so that all licenses would expire simultaneously.

The invoices received for the period of May 1, 2019 through April 30, 2020, is for the fourth year of the original contract at the agreed amount and the second year of the addendum at the agreed upon rate.

Attached are invoices 025-255624 and 025-255625 in a combined amount of \$88,146.00 (Attachment A).

Fiscal Impact:

The Tyler software license and services cost has been included in the approved General Fund FY 2018-2019 budget under Account No. 100-1230-7071-0000.

Finance Director Review: 

Recommendation:

1. Approve Tyler Technologies invoices 025-255624 and 025-255625 for

\$88,146.00.

City Manager Review: 

Attachments:

- A. Tyler Technologies invoices related to annual software license and services.

Attachment A



Remittance:
 Tyler Technologies, Inc.
 (FEIN 75-2303920)
 P.O. Box 203556
 Dallas, TX 75320-3556

Invoice

<i>Invoice No</i>	<i>Date</i>	<i>Page</i>
025-255625	04/17/2019	1 of 1

Questions:
 Tyler Technologies - Local Government
 Phone: 1-800-772-2260 Press 2, then 2
 Email: ar@tylertech.com

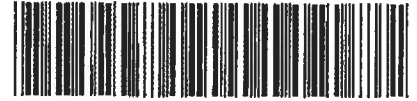

Bill To: Beaumont, CA, City of
 550 E 6th St.
 Beaumont, CA 92223

Ship To: Beaumont, CA, City of
 550 E 6th St.
 Beaumont, CA 92223

<i>Customer No.</i>	<i>Ord No</i>	<i>PO Number</i>	<i>Currency</i>	<i>Terms</i>	<i>Due Date</i>
42174	67581	2016-0124	USD	NET45	06/01/2019

Description	Extended Price
Schedule 3 - New Tyler Software Added to SaaS: 05/01/2019 - 04/30/2020	73,169.00

Milestone Details

Description:	Contract Amount:	Percent Invoiced:	Amount Invoiced:
Annual Subscription Fee - Schedule 3 - New Incode Software Added to SaaS	195,461.14	14%	27,923.02
Annual User Fee (30 Named Users) - Schedule 3 - New Tyler Software Added to SaaS	120,960.00	14%	17,280.00
Annual Subscription Fees - Schedule 3 - New EnerGov Software Added to SaaS	163,561.86	14%	23,365.98
Annual Hosting User Fee - Additional Users to SaaS contract #2016-0124 (6 Users) (05/01/18-04/30/23)	17,250.00	20%	3,450.00
Annual Hosting User Fee (2 Users)	4,600.00	25%	1,150.00

****ATTENTION****
 Order your checks and forms from
 Tyler Business Forms at 877-749-2090 or
 tylerbusinessforms.com to guarantee
 100% compliance with your software.

Subtotal	73,169.00
Sales Tax	0.00
Invoice Total	73,169.00



Remittance:
 Tyler Technologies, Inc.
 (FEIN 75-2303920)
 P.O. Box 203556
 Dallas, TX 75320-3556

Invoice

<i>Invoice No</i>	<i>Date</i>	<i>Page</i>
025-255624	04/17/2019	1 of 1

Questions:
 Tyler Technologies - Local Government
 Phone: 1-800-772-2260 Press 2, then 2
 Email: ar@tylertech.com

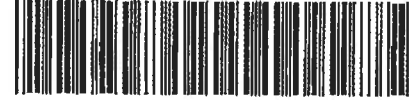

Bill To: Beaumont, CA, City of
 550 E 6th St.
 Beaumont, CA 92223

Ship To: Beaumont, CA, City of
 550 E 6th St.
 Beaumont, CA 92223

<i>Customer No.</i>	<i>Ord No</i>	<i>PO Number</i>	<i>Currency</i>	<i>Terms</i>	<i>Due Date</i>
42474	67581	2016-0124	USD	NET45	06/01/2019

Description	Extended Price
Schedule 2 - Tyler Software Migration to SaaS: 05/01/2019 - 04/30/2020	14,977.00

Milestone Details

Description:	Contract Amount:	Percent Invoiced:	Amount Invoiced:
Annual Subscripilon Fee - Schedule 2 - Tyler Software Migration to SaaS	104,839.00	14%	14,977.00

****ATTENTION****
 Order your checks and forms from
 Tyler Business Forms at 877-749-2090 or
 tylerbusinessforms.com to guarantee
 100% compliance with your software.

Subtotal	14,977.00
Sales Tax	0.00
Invoice Total	14,977.00

Staff Report

TO: Mayor and Council Members
FROM: Jeff Hart, Public Works Director
DATE: May 21, 2019
SUBJECT: Approval for Purchase of Crack Seal Machine

Background and Analysis:

Road maintenance is part of the Pavement Management System (PMS) and includes the application of crack seal, slurry seal, grind and overlay, and full depth rehabilitation. The most common distress that develops in roads is cracks, and crack seal application helps increase the life of the roadway. The application of crack seal over cracks in the asphalt reduces water infiltration which can worsen the structural integrity of the pavement section.

The Public Works Department has obtained quotes to purchase a crack seal machine from CrafcO (see Attachment A). CrafcO is registered with Sourcewell, which is a public agency that offers competitively solicited, cooperative contracts for the purchase of products and services. The City of Beaumont purchasing ordinance requires three (3) quotes from vendors before purchasing the product from the lowest bidder, however; all of the contracts and products offered through Sourcewell have gone through the competitive bidding process and the products are certified to be sold at the lowest price. Sourcewell issued CrafcO a vendor license number which assures that CrafcO is selling products to public agencies at the lowest price and fulling the competitive bidding process. The vendor license number for CrafcO is #052417-CFC (see Attachment C).

The crack seal machine from CrafcO comes with or without a compressor unit. The crack seal machine with the compressor unit mounted to the same trailer costs an additional \$28,010.69. The increased cost reflects the bigger motor and trailer that is required to operate and tow the compressor unit mounted with the crack seal machine. The compressor unit allows instant cleaning of debris within the cracks, after cleaning of debris, hot emulsified asphalt is applied to seal the crack. Instant cleaning and sealing of the crack will increase productivity, efficiency, and provide for better repairs. Attachment A contains the CrafcO quote which includes the compressor unit. Attachment B contains the CrafcO quote which excludes the compressor unit.

Staff recommends purchasing the crack seal machine with the compressor unit. Staff recommends City Council approve the CrafcO quote in the amount of \$80,819.93 to purchase the crack seal machine.

Fiscal Impact:

Measure A funds will be allocated to purchase the crack seal machine. Routinely purchasing of supplies for the machine will be purchased through the special department supply account and Measure A funds.

Finance Director Review: 

Recommendation:

1. Approve of the CrafcO quote in the amount of \$80,819.93 to allow the Public Works Department to purchase a crack seal machine.

City Manager Review: 

Attachments:

- A. CrafcO Quote for Crack Seal Machine Including Compressor Unit
- B. CrafcO Quote for Crack Seal Machine Excluding Compressor Unit
- C. CrafcO Vendor License Number #052417-CFC
- D. City of Beaumont Purchasing Ordinance

Attachment A

Crafco Quote for Crack Seal Machine Including Compressor Unit



6165 W. Detroit St.
 Chandler, AZ 85226
 (602) 276-0406 (800) 528-8242
 FAX: (480) 940-0313

QUOTE # BBBQ31471

Date Quoted 4/30/2019
 EXPIRATION DATE 6/14/2019

Quote To: Account Code: 926977

Ship To: Account Code: 926977

CITY OF BEAUMONT - CA STREET
MARTIN GUTIERREZ
 550 EAST 6TH STREET
 BEAUMONT, CA 92223
 US

CITY OF BEAUMONT - CA STREET MAINTENANCE
 550 EAST 6TH STREET
 BEAUMONT, CA 92223
 US

Phone: 951-769-8520

Fax:

Email: MGUTIERREZ@CI.BEAUMONT.CA.US

MARTIN GUTIERREZ

951-769-8520

MGUTIERREZ@CI.BEAUMONT.CA.US

Project Title:

Bid Date:

Bid Number:

Project Start Date: 4/30/2019

Ship Before: 6/14/2019

Quote Effective Dates: 4/30/2019 TO 6/14/2019

Terms: NET 30

F.O.B.: PPD-ADD FREIGHT

Ship Via: Truck/Common Carrier

Sales Group:

Quoted By: Rob Manriquez

Sales Office: WR4- Rob Manriquez

Estimated Time to Ship After Receipt of Order: Quoted at time of order

Customer: CITY OF BEAUMONT - CA STREET

Quote Number BBBQ31471

Project Title:

Date 04-30-19

SALES TAX EXEMPT CERTIFICATE MUST BE PROVIDED AT THE TIME OF ORDER OR SALES TAX WILL BE ADDED TO YOUR ORDER

Part #	Description	Unit	Qty.	Quote Price	Ext. Price
47400-SRC	SUPERSHOT 125D W/100 CFM COMPRESSOR	ea	1	\$69,660.0000	\$69,660.0000
20014-SRC	3" PINTLE HITCH	ea	1	\$114.2400	\$114.2400
24227-SRC	SEVEN PIN ROUND BLADE CONNECTOR	ea	1	\$51.8200	\$51.8200
20120-SRC	18" HITCH EXTENSION	ea	1	\$496.0000	\$496.0000
24086-SRC	LOCKABLE BATTERY BOX	ea	1	\$133.6000	\$133.6000
24095K-SRC	STROBE LIGHT KIT INSTALLED	ea	1	\$273.6000	\$273.6000
24190K-SRC	OVERNIGHT HEATER	ea	1	\$288.0000	\$288.0000
26058-SRC	10# FIRE EXTINGUISHER (MUST ORDER 26059 TO MOUNT)	ea	1	\$192.0000	\$192.0000
26059-SRC	FIRE EXTINGUISHER BRACKET	ea	1	\$76.0000	\$76.0000
26119-SRC	3/8" SAFETY HOOK W/ LATCH (2 REQUIRED)	ea	2	\$52.0000	\$104.0000
43416-SRC	GRAVITY FEED KIT	ea	1	\$240.0000	\$240.0000
43549-SRC	SPARE TIRE KIT	ea	1	\$296.0000	\$296.0000
47534N-SRC	ENGINE COVER ASSY 4LE2T INSULATED	ea	1	\$2,664.0000	\$2,664.0000

Customer: CITY OF BEAUMONT - CA STREET
Project Title:

Quote Number BBBQ31471
Date 04-30-19

SALES TAX EXEMPT CERTIFICATE MUST BE PROVIDED AT THE TIME OF ORDER OR SALES TAX WILL BE ADDED TO YOUR ORDER

Part #	Description	Unit	Qty.	Quote Price	Ext. Price	
					Sub Total	\$74,589.26
					Sales Tax	\$5,780.66
						\$80,119.93

COMMENTS:

FOB Chandler, AZ
Free training and 2 year warranty provided upon delivery
30-45 Days ARO
For questions contact Rob Manriquez at (909)238-8416 or rob.manriquez@crafco.com
Sourcewell pricing per Vendor #052417-CFC

NOTE:

WARNING:

Products on this quote may be labeled in accordance with California Proposition 65.
California purchasers refer to <http://crafco.com/resources/Prop-65.xlsx>

For Terms and Conditions of purchases go to: www.crafco.com/Terms-of-Sale.pdf

Quantities may be limited at Crafco's discretion.
Pricing and availability are subject to change without notice.
Pricing does not include applicable taxes. Tax exemption forms must be on file prior to invoicing. Unpaid sales tax will be reported to State and Local tax authorities. Extension is net after terms.

FOB DEFINITIONS:

- CFR- Seller pays for the carriage of goods up to the named port of destination.
- CIF- Same as CFR with exception that the seller is required to obtain insurance for the goods while in transit to the named port of destination.
- CIP- Same as CPT with exception that the seller is required to obtain insurance for the goods while in transit.
- COL- Collect
- CPT- Seller pays for the carriage of the goods up to the named place of destination.
- DAF- Seller pays for transportation to the named place of delivery at the frontier. Rail or Road.
- DAP- Seller delivers when the goods are placed at the disposal of the buyer on the arriving means of transport ready for unloading at the named place of destination.
- DDP- Seller is responsible for delivering the goods to the named place in the country of the buyer, and pays all costs in bringing the goods to the destination including import duties and taxes.
- DDU- Seller delivers the goods to the buyer to the named place of destination in the contract of sale.
- DEQ- Same as DES, but the passing risk does not occur until the goods have been unloaded at the port of discharge.
- DES- Seller pays the same freight and insurance costs but the passing risk does not occur until the ship has arrived at the named port of destination and the goods made available for unloading to the buyer.
- DLB- Delivered, buyer pays.
- DLV- Delivered, seller pays.
- EXW- Seller makes the goods available at their premises, or at another named place.
- FAS- Seller delivers when the goods are placed alongside the buyer's vessel at the named port of destination.
- FCA- Seller delivers the goods, cleared for export, at a named place (possibly including the seller's own premises).
- FF- Free House.
- FOB- Seller bears all costs and risks up to the point the goods are loaded on board the vessel.
- PPA- Delivered; freight included.
- PPD- Delivered; freight separate.
- UN- Not free.

Pavement Preservation Products Restocking Policy

Crafco will only accept the return of products that have been authorized in writing in advance. To obtain authorization contact your customer service representative. A written authorization will be faxed or emailed to you. A copy of the RETURN AUTHORIZATION must accompany the material being returned.

Not all products are returnable. Products that have a shelf life or are considered made to order or special order may not be returned. No used parts may be returned.

All returns are subject to restocking charges.

All products returned must be in the original packaging and be in good and salable condition. Crafco reserves the right to charge repackaging charges in addition to restocking charges.

Restocking Charges

- PARTS (*) 15%
- EQUIPMENT Non Returnable
- SEALANT (*) 25%
- SILICONE Non Returnable
- GEOCOMPOSITES Non Returnable
- MASTIC (*) 25%
- POLYPATCH (*) 25%
- TECHCRETE (*) 25%
- OTHER STANDARD INVENTORIED ITEMS (*) 25%

CUSTOMER IS RESPONSIBLE FOR ALL SHIPPING COSTS ON RETURNED MATERIALS.

(*) Not all purchases are returnable. Any part or product that is non-standard or obsolete is not returnable. Request information on the acceptability for returns for any specific product when ordering.

Attachment B

Crafco Quote for Crack Seal Machine Excluding Compressor Unit



6165 W. Detroit St.
 Chandler, AZ 85226
 (602) 276-0406 (800) 528-8242
 FAX: (480) 940-0313

QUOTE # BBBQ29774

Date Quoted 2/4/2019
 EXPIRATION DATE 5/15/2019

Quote To: Account Code: 926977

Ship To: Account Code: 926977

**CITY OF BEAUMONT - CA STREET
 MARTIN GUTIERREZ**

CITY OF BEAUMONT - CA STREET MAINTENANCE

550 EAST 6TH STREET
 BEAUMONT, CA 92223
 US

550 EAST 6TH STREET
 BEAUMONT, CA 92223
 US

Phone: 951-769-8520

Fax:

Email: MGUTIERREZ@CI.BEAUMONT.CA.US

MARTIN GUTIERREZ

951-769-8520

MGUTIERREZ@CI.BEAUMONT.CA.US

Project Title:

Bid Date:

Terms: NET 30

Bid Number:

F.O.B.: PPD-ADD FREIGHT

Project Start Date: 2/4/2019

Ship Via: Truck/Common Carrier

Ship Before: 5/15/2019

Sales Group:

Quote Effective Dates: 2/4/2019 TO 5/15/2019

Quoted By: Rob Manriquez

Sales Office: WR4- Rob Manriquez

Estimated Time to Ship After Receipt of Order: Quoted at time of order

Customer: CITY OF BEAUMONT - CA STREET

Quote Number BBBQ29774

Project Title:

Date 02-04-19

SALES TAX EXEMPT CERTIFICATE MUST BE PROVIDED AT THE TIME OF ORDER OR SALES TAX WILL BE ADDED TO YOUR ORDER

Part #	Description	Unit	Qty.	Quote Price	Ext. Price
43600-SRC	SUPERSHOT 125 DIESEL	ea	1	\$44,928.0000	\$44,928.0000
20014-SRC	3" PINTLE HITCH	ea	1	\$114.2400	\$114.2400
24227-SRC	SEVEN PIN ROUND BLADE CONNECTOR	ea	1	\$51.8200	\$51.8200
20120-SRC	18" HITCH EXTENSION	ea	1	\$496.0000	\$496.0000
24086-SRC	LOCKABLE BATTERY BOX	ea	1	\$133.6000	\$133.6000
24095K-SRC	STROBE LIGHT KIT INSTALLED	ea	1	\$273.6000	\$273.6000
24190K-SRC	OVERNIGHT HEATER	ea	1	\$288.0000	\$288.0000
26058-SRC	10# FIRE EXTINGUISHER (MUST ORDER 26059 TO MOUNT)	ea	1	\$192.0000	\$192.0000
26059-SRC	FIRE EXTINGUISHER BRACKET	ea	1	\$76.0000	\$76.0000
26119-SRC	3/8" SAFETY HOOK W/ LATCH (2 REQUIRED)	ea	2	\$52.0000	\$104.0000
43416-SRC	GRAVITY FEED KIT	ea	1	\$240.0000	\$240.0000
43549-SRC	SPARE TIRE KIT	ea	1	\$296.0000	\$296.0000
45599-SRC	ENGINE COVER/TIER 2-INSULATED	ea	1	\$1,400.0000	\$1,400.0000

Customer: CITY OF BEAUMONT - CA STREET
Project Title:

Quote Number: BBB029774
Date: 02-04-19

SALES TAX EXEMPT CERTIFICATE MUST BE PROVIDED AT THE TIME OF ORDER OR SALES TAX WILL BE ADDED TO YOUR ORDER

Part #	Description	Unit	Qty.	Quote Price	Ext. Price
				Sub Total	\$48,593.26
				Sales Tax	\$3,765.97
COMMENTS:					\$52,809.24

FOB Chandler, AZ
 Free training and 2 year warranty provided upon delivery
 30-45 Days ARO
 For questions contact Rob Manriquez at (909)238-8416 or rob.manriquez@crafco.com
 Sourcewell pricing per Vendor #052417-CFC

NOTE:

WARNING:

Products on this quote may be labeled in accordance with California Proposition 65. California purchasers refer to <http://crafco.com/resources/Prop-65.xlsx>

For Terms and Conditions of purchases go to: www.crafco.com/Terms-of-Sale.pdf
 Quantities may be limited at Crafco's discretion.

Pricing and availability are subject to change without notice.

Pricing does not include applicable taxes. Tax exemption forms must be on file prior to invoicing. Unpaid sales tax will be reported to State and Local tax authorities. Extension is net after terms.

FOB DEFINITIONS:

CFR- Seller pays for the carriage of goods up to the named port of destination.

CIF- Same as CFR with exception that the seller is required to obtain insurance for the goods while in transit to the named port of destination.

CIP- Same as CPT with exception that the seller is required to obtain insurance for the goods while in transit.

COL- Collect

CPT- Seller pays for the carriage of the goods up to the named place of destination.

DAF- Seller pays for transportation to the named place of delivery at the frontier. Rail or Road.

DAP- Seller delivers when the goods are placed at the disposal of the buyer on the arriving means of transport ready for unloading at the named place of destination.

DDP- Seller is responsible for delivering the goods to the named place in the country of the buyer, and pays all costs in bringing the goods to the destination including import duties and taxes.

DDU- Seller delivers the goods to the buyer to the named place of destination in the contract of sale.

DEQ- Same as DES, but the passing risk does not occur until the goods have been unloaded at the port of discharge.

DES- Seller pays the same freight and insurance costs but the passing risk does not occur until the ship has arrived at the named port of destination and the goods made available for unloading to the buyer.

DLB- Delivered, buyer pays.

DLV- Delivered, seller pays.

EXW- Seller makes the goods available at their premises, or at another named place.

FAS- Seller delivers when the goods are placed alongside the buyer's vessel at the named port of destination.

FCA- Seller delivers the goods, cleared for export, at a named place (possibly including the seller's own premises).

FH- Free House.

FOB- Seller bears all costs and risks up to the point the goods are loaded on board the vessel.

PPA- Delivered; freight included.

PPD- Delivered; freight separate.

UN- Not free.

Pavement Preservation Products Restocking Policy

Crafco will only accept the return of products that have been authorized in writing in advance. To obtain authorization contact your customer service representative. A written authorization will be faxed or emailed to you. A copy of the RETURN AUTHORIZATION must accompany the material being returned.

Not all products are returnable. Products that have a shelf life or are considered made to order or special order may not be returned. No used parts may be returned.

All returns are subject to restocking charges.

All products returned must be in the original packaging and be in good and salable condition. Crafco reserves the right to charge repackaging charges in addition to restocking charges.

Restocking Charges

PARTS (*) 15%

EQUIPMENT Non Returnable

SEALANT (*) 25%

SILICONE Non Returnable

GEOCOMPOSITES Non Returnable

MASTIC (*) 25%

POLYPATCH (*) 25%

TECHCRETE (*) 25%

OTHER STANDARD INVENTORIED ITEMS (*) 25%

CUSTOMER IS RESPONSIBLE FOR ALL SHIPPING COSTS ON RETURNED MATERIALS.

(*) Not all purchases are returnable. Any part or product that is non-standard or obsolete is not returnable. Request information on the acceptability for returns for any specific product when ordering.

Attachment C

Crafco Vendor License Number #052417-CFC

← Vendors & Contracts



Crafco, Inc.

Roadway Maintenance Equipment with Related Accessories, Attachments, Materials, and Supplies

#052417-CFC

Maturity Date: 10/02/2021

Products & Services

Contract Documents

Pricing

Contact Information

Products & Services

Sourcewell contract 052417-CFC gives access to the following types of goods and services:

- Pavement preservation and maintenance solutions
- Melter/applicators to heat and place sealants and
- Spray injection patching equipment used in the repair of pavement potholes and voids, patchers for applying hot-applied mastics and sealcoat

Attachment D

City of Beaumont Purchasing Ordinance

Chapter 3.01 - SPECIFIC PROVISIONS FOR BIDDING, CONTRACTING AND PURCHASES

121

Sections:

Footnotes:

3.01.010 - Definitions.

Unless otherwise indicated, the following definitions shall apply to all provisions of this chapter:

"Alternative procedure" means purchasing supplies, services or equipment by negotiated contract, purchase order or any other procedure outlined in the City's purchasing and bidding policies and procedures manual approved by the City Manager and consistent with this chapter. A type of alternative procedure may include, but is not limited to, what will be referred to as a "simplified pricing procedure" wherein the Authorized Contracting Party, or his or her designee, obtains oral price quotes from one or more potential contractors or suppliers, and accepts the quote which is determined to be in the best interests of the City.

"Authorized Contracting Party" means the City official or body provided with authority under this chapter by the City Manager to approve a contract or to make a purchase.

"City Manager" means the City Manager or person designated by the City Manager to perform all or some of the duties prescribed in this chapter.

"Commission" means the California Uniform Construction Cost Accounting Commission created by Division 2, Part 3, Chapter 2, Article 2 of the California Public Contract Code (Section 22000 et seq.).

"Emergency" for purposes of public projects shall have that meaning provided in California Public Contract Code Sections 22035 and 22050. Emergency for all other purchasing or contracting purposes means a situation which makes competitive bidding, either formal or informal, impractical or not in the best interests of the City.

"Facility" means any plant, building, structure, ground facility, utility system (subject to the limitation found in California Public Contract Code Section 22002, Subdivision (c)(3)), real property, streets and highways, or other public work improvement.

"General services" means all services performed by persons not in a professional occupation, including, but not limited to, contract services for park, electrical and computer repair, building, facility and vehicle maintenance, recreation programs and other similar services which are not professional services.

"Maintenance work" shall have that meaning provided in Section 22002(d) of the Public Contract Code, as that section may be amended from time to time. In addition and to the extent not inconsistent with Section 22002(d), maintenance work shall include, but shall not be limited to, the following:

- A. Routine, recurring and usual work for the preservation or protection of any publicly owned or publicly operated facility for its intended purposes;
- B. Minor repainting;
- C. Street and highway maintenance, including utility patching, skin patching, crack filling, filling of pot holes, slurry sealing, edge grading, street striping, resurfacing of streets and highways at less than one-inch, sign replacement, sidewalk repair and replacement, curb and gutter repair and replacement, and street and traffic light repair and replacement. Maintenance work shall not include striping of a new street or highway;
- D. Sewer maintenance, including foaming, videotaping, cleaning and manhole restoration;

- E. Traffic signal maintenance. Maintenance work shall not include installation of new traffic signals;
- F. Storm drain related maintenance;
- G. Landscape maintenance, including mowing, watering, trimming, pruning, planting, tree and plant replacement, irrigation and sprinkler system servicing, retrofit and repair and landscape rehabilitation;
- H. Maintenance of facilities, including roof repairs or replacements, heating and air conditioning repairs and electric repairs;
- I. Vehicle and equipment maintenance and repairs;
- J. Work performed to keep, operate, and maintain publicly owned waste disposal systems, including, but not limited to dams, reservoirs and waste treatment systems.

"Professional services" means all services performed by persons in a professional occupation, including, but not limited to, consulting and performance services for legal services, accounting, auditing, computer hardware and software support, engineering, architectural, planning, environmental, redevelopment, financial, economic, personnel, social services, animal control, management, solid waste, cable television, communication and other similar professional functions which may be necessary for the operation of the City. Professional Services are governed by chapter 3.02.

"Public project" shall have that meaning provided in Section 22002(c) of the Public Contract Code, as that section may be amended from time to time. A public project shall not include maintenance work. In addition and to the extent not inconsistent with Section 22002(c), public project shall include, but shall not be limited to, the following:

1. Construction, reconstruction, erection, alteration, renovation, improvement, demolition and repair work involving any publicly owned, leased or operated facility;
2. Street or sewer work except maintenance and repair;
3. Painting or repainting of any publicly owned, leased or operated facility; and
4. In the case of a publicly owned utility system, public project shall include only the construction, erection, improvement, or repair of dams, reservoirs and wastewater treatment plants.

"Public project formal bidding procedure" means the procedure provided for in Section 3.01.060 which meets the requirements of state and local law, including Public Contract Code Section 22037, this chapter and any policies and procedures approved by the City Manager consistent with this chapter.

"Public project informal bidding procedure" means a procedure provided for in Section 3.01.070 which meets the requirements of state and local law, including Public Contract Code Section 22034, this chapter and any policies and procedures approved by the City Manager consistent with this chapter.

"Purchasing Officer" means the City Manager or his or her designee(s) as provided in Section 3.00.020. Pursuant to Section 3.00.020, the City Manager may change his or her designation at any time.

"Non-public project formal bidding procedure" means the procedure provided for in Section 3.01.080 which meets the requirements of state and local law, including the Public Contract Code, this chapter and any policies and procedures approved by the City Manager consistent with this chapter.

"Non-public project informal bidding procedure" means the procedure provided for in Section 3.01.090 which meets the requirements of state and local law, including the Public Contract Code, this chapter and any policies and procedures approved by the City Manager consistent with this chapter.

(Ord. No. 1097, § 3(Exh. A), 11-21-2017)

3.01.020 - General purchasing policies and procedures.

- A. The City shall secure supplies, services and equipment at the lowest total cost commensurate with the quality and scope needed, and subject to any limitations imposed by state law.

- B. The Purchasing Officer shall develop, for approval by the City Manager, such policies and procedures as are necessary to implement the provisions of this chapter. The policies and procedures shall be written and implemented in such a way to encourage open and competitive bidding, where appropriate, provide equal opportunity based on merit, make each selection process free of invidious discrimination, provide for efficient and timely acquisition of needed supplies, services and equipment, and provide effective fiscal controls.
- C. In purchasing, supplies, services and equipment, the City shall make use of competitive bidding, both formal and informal, whenever required by law, this chapter or any policies and procedures approved by the City Manager consistent with this chapter.
- D. Formal and informal competitive bidding is not required, for instance, when an emergency is declared pursuant to this chapter.
- E. Except in cases of emergency or unless specifically authorized by resolution or minute order of the City Council, the Purchasing Officer shall not issue a purchase order for supplies, services or equipment involving any project or purchase unless there exists an unencumbered appropriation in the fund account against which such purchase is to be charged.
- F. The City shall comply with all federal and state bidder's security and bonding requirements and all prevailing wage laws applicable to each contract or purchase.
- G. The Purchasing Officer, with approval of the City Manager, may provide written authorization to any department director to conduct a bidding process outside of the centralized purchasing system; provided, however, that such bidding process and the resulting contract or purchase shall otherwise comply with the requirements of this chapter. The Purchasing Officer, with approval of the City Manager, may rescind such authorization in writing at any time and for any or no reason.

(Ord. No. 1097, § 3(Exh. A), 11-21-2017)

3.01.030 - Bidding requirements for public projects.

- A. *Alternative Procedure (up to \$25,000.00) (Administrative Approval).* Public projects with cost estimates of \$25,000.00 or less may be awarded by the City Manager, upon recommendation of the director of the department responsible for the project, by any alternative procedure as defined in Section 3.01.010.
- B. *Alternative Procedure (more than \$25,000.00—\$45,000.00) (City Council Approval).* Public projects with cost estimates of more than \$25,000.00, but less than, or equal to \$45,000.00 may be awarded by the City Council, upon recommendation of the City Manager, by any alternative procedure as defined in Section 3.01.010.
- C. *Informal Procedure (more than \$45,000.00—less than \$175,000.00).* Public projects with cost estimates of more than \$45,000.00, but less than, or equal to, \$175,000.00 shall, except as otherwise provided in this chapter or the Public Contract Code, be awarded by the City Council pursuant to the public project informal bidding procedure in Section 3.01.070. If all bids received are over \$175,000.00, the City Council may, with the approval of a four-fifths vote of those members present, award the contract in an amount not exceeding \$187,500.00 to the lowest responsive and responsible bidder, so long as the City Council also determines that the City's cost estimate for the project was reasonable.
- D. *Formal Procedure (more than \$175,000.00).* Public projects with cost estimates of more than \$175,000.00 shall, except as otherwise provided in this chapter or the Public Contract Code, be awarded by the City Council pursuant to the public project formal bidding procedure in Section 3.01.060.
- E. *City Engineer Review.* The City Engineer or his designee shall review the working details, drawings, plans and specifications prepared for every maintenance project and other general services project

which may affect the design or operation of public improvements and which may bring into question the City's liability for dangerous condition of public property.

- F. *City Council Approval.* The City Council shall review and approve the working details, drawings, plans and specifications prepared for every public project of more than \$175,000.00.
- G. *Award.* Contracts for public projects of \$45,000.00 or less, may be awarded in the best interests of the City. Contracts for public projects of more than \$45,000.00, if awarded, shall be awarded to the lowest responsive and responsible bidder. If two or more bids are the same and the lowest, the Authorized Contracting Party may accept the one it chooses in his or her sole and absolute discretion.
- H. *Dollar Limits and Change Orders or Amendments.* The dollar limits indicated herein shall apply to the original contract and to any amendments or change orders. To this end, therefore, unless an exception provided in Section 3.01.100 applies, any contract amendment or change order which would increase the contract amount above any threshold stated herein shall comply with the requirements applicable to the increased contract amount.
- I. *No Bid Splitting.* The City shall not split a project, work, service or purchase into smaller projects, works, services or purchases for the purpose of avoiding any bidding or contracting requirements of this Code.

(Ord. No. 1097, § 3(Exh. A), 11-21-2017)

3.01.040 - Bidding requirements for maintenance and general services.

- A. *Alternative Procedure (up to \$25,000.00) (Administrative Approval).* Maintenance work and other general services projects with cost estimates of \$25,000.00 or less may be awarded by the City Manager, upon recommendation of the director of the department responsible for the project, by any alternative procedure as defined in Section 3.01.010.
- B. *Alternative Procedure (more than \$25,000.00—\$45,000.00) (City Council Approval).* Maintenance work and other general services projects with cost estimates of more than \$25,000.00, but less than, or equal to \$45,000.00 may be awarded by the City Council, upon recommendation of the City Manager, by any alternative procedure as defined in Section 3.01.010.
- C. *Informal Bidding Procedure (more than \$45,000.00—up to \$175,000.00).* Maintenance work and other general services projects with cost estimates of more than \$45,000.00, but less than or equal to \$175,000.00 shall, except as otherwise provided in this chapter, be awarded by the City Council pursuant to the non-public project informal bidding procedure contained in in Section 3.01.090.
- D. *Formal Bidding Procedure (more than \$175,000.00).* Maintenance work and other general services projects with cost estimates of more than \$175,000.00 shall, except as otherwise provided in this chapter, be awarded by the City Council pursuant to the non-public project formal bidding procedure contained in Section 3.01.080.
- E. *City Engineer Review.* The City Engineer or his designee shall review the working details, drawings, plans and specifications prepared for every maintenance project and other general services project which may affect the design or operation of public improvements and which may bring into question the City's liability for dangerous condition of public property.
- F. *Purchasing Officer Approval.* The Purchasing Officer, or his or her designee, shall review and approve the working details, drawings, plans and specifications prepared for every maintenance work and other general services project.
- G. *City Council Approval.* The City Council shall review and approve the working details, drawings, plans and specifications prepared for every maintenance work and other general services project of more than \$45,000.00.

- H. *Award.* Contracts for maintenance work and other general services projects of \$45,000.00 or less, if awarded, may be awarded in the best interests of the City. Contracts for maintenance work and other general services projects of more than \$45,000.00, if awarded, shall be awarded to the lowest responsive and responsible bidder. If two or more bids are the same and the lowest, the Authorized Contracting Party may accept the one it chooses.
- I. *Subsequent Contract Awards, Amendments, Extensions or Renewals.* Notwithstanding anything herein to the contrary, the City Manager shall not award a subsequent contract to the same individual or entity for the same or similar services on the same project, or amend, extend or renew such a contract, without City Council approval, when the award, amendment, extension or renewal will result in the City paying an aggregate amount of more than \$45,000.00 to the individual or entity in any given fiscal year. For purposes of this section, the phrase "same project" shall include an on-call or as-needed contract.
- J. *Term Limitation.* No maintenance work or other general services contract, except for contracts for solid waste services, may extend for longer than a three-year initial term with a maximum of two, one-year extensions each of which must be approved by the City Council.
- K. *No Bid Splitting.* The City shall not split a project, work, service or purchase into smaller projects, works, services or purchases for the purpose of avoiding any bidding or contracting requirements of this Code.

(Ord. No. 1097, § 3(Exh. A), 11-21-2017)

3.01.050 - Bidding requirements for materials, supplies and equipment.

- A. *Alternative Procedure (up to \$25,000.00) (Administrative Approval).* Purchases of materials, supplies and equipment of \$25,000.00 or less may be awarded by the City Manager, upon recommendation of the director of the department responsible for the project, by any alternative procedure as defined in Section 3.01.010.
- B. *Alternative Procedure (more than \$25,000.00—\$45,000.00) (City Council Approval).* Purchases of materials, supplies and equipment of more than \$25,000.00, but less than, or equal to \$45,000.00 may be awarded by the City Council, upon recommendation of the City Manager, by any alternative procedure as defined in Section 3.01.010.
- C. *Informal Bidding Procedure (more than \$45,000.00—less than \$175,000.00).* Purchases of materials, supplies and equipment of more than \$45,000.00, but less than or equal to \$175,000.00 shall, except as otherwise provided in this chapter, be awarded by the City Council pursuant to the non-public project informal bidding procedure provided for in Section 3.01.090.
- D. *Formal Bidding Procedure (\$175,000.00 or more).* Purchases of materials, supplies and equipment of more than \$175,000.00 shall, except as otherwise provided in this chapter, be awarded by the City Council pursuant to the non-public project formal bidding procedure provided for in Section 3.01.080.
- E. *Department Director Approval.* The director of the appropriate department shall review and approve the specifications prepared for every purchase of materials, supplies and equipment.
- F. *Purchasing Officer Approval.* The Purchasing Officer, or his or her designee, shall review and approve all contracts for the purchase of materials, supplies and equipment.
- G. *City Council Approval.* The City Council shall review and approve the specifications prepared for every purchase of materials, supplies and equipment of more than \$45,000.00.
- H. *Award.* Contracts for the purchase of materials, supplies and equipment of \$45,000.00 or less, if awarded, may be awarded in the best interests of the City pursuant to Section 3.01.040.G. Contracts for the purchase of materials, supplies and equipment of more than \$45,000.00, if awarded, shall be awarded to the lowest responsive and responsible bidder pursuant to Section 3.01.040.G. If two or

more bids are the same and the lowest, the Authorized Contracting Party may accept the one he or she chooses in his or her sole discretion.

- I. *Local Bidder Preference.* In order to promote the economic health of the City and to encourage local participation in the procurement of materials, supplies and equipment, the City may take into consideration the sales tax to be returned to the City as a result of an award in determining the lowest responsive and responsible bidder. This section shall not be effective unless and until the City Manager adopts a written policy to implement its provisions.
- J. *No Bid Splitting.* The City shall not split a project, work, service or purchase into smaller projects, works, services or purchases for the purpose of avoiding any bidding or contracting requirements of this Code.

(Ord. No. 1097, § 3(Exh. A), 11-21-2017)

3.01.060 - Formal bidding procedure for public projects.

- A. *Uses of Formal Bidding Procedure.* This formal bidding procedure shall be used whenever formal bidding is required for a public project.
- B. *Required Process.* The formal competitive bidding procedure shall comply with all aspects of state and local law governing formal competitive bidding, including, but not limited to, the California Public Contract Code, California Government Code, California Labor Code, resolutions of the City Council as may be adopted from time to time, and policies and procedures as the City Manager may approve from time to time.
- C. *Notice Inviting Formal Bids.* Notice inviting formal bids shall be provided. The notice inviting formal bids shall comply with Public Contract Code Section 22037, as such section may be amended from time to time. Notices shall state the time and place for the receiving and opening of sealed bids and distinctly describe the project. At a minimum, the notice inviting formal bids shall:
 - 1. Describe the project;
 - 2. State how to obtain more detailed information about the project;
 - 3. State the date, time and place for the submission of sealed bids; and
 - 4. Include any other information required by state or local law, as determined by the City Attorney.
- D. *Published Notice.* The notice shall be published at least fourteen calendar days before the date of opening the bids in a newspaper of general circulation printed and published in the City, or, if there is no such newspaper, in a newspaper of general circulation which is circulated in the City.
- E. *Distribution of Notice Inviting Formal Bids.* The notice inviting formal bids shall also be sent to those construction trade journals specified in Public Contract Code Section 22036 at least thirty calendar days before the date of bid opening.
- F. *Additional Notice.* The City shall also provide any additional notice as it deems proper.
- G. *Contents of Remaining Bid and Contract Documents.* The contents and form of the bid and contract documents shall be approved by the director of the appropriate department, as well as the City Attorney.
- H. *City's Authority.* The City may reject any or all bids received, and may waive any minor irregularities in each bid received.
- I. *No Bids Received.* If no bids are received, the Authorized Contracting Party may award the contract by any alternative procedure.
- J. *Award of Contract.* The contract shall be awarded in accordance with Section 3.01.030. If two or more bids are the same and the lowest, the City may accept the one it chooses in its sole and absolute discretion.

- K. *Rejection of Bids.* The City may, in its sole and absolute discretion, reject any bids presented. If after the first invitation of bids all bids are rejected, after reevaluating its cost estimates for the project, the City shall have the option of any of the following:
1. Abandon the project; or
 2. Re-advertise for bids in the manner described in this chapter; or
 3. By passage of a resolution by a four-fifths vote of the City Council, declare that the project can be performed more economically by the employees of the City and have the project done by force account.

(Ord. No. 1097, § 3(Exh. A), 11-21-2017)

3.01.070 - Informal bidding procedure for certain public projects.

- A. *Uses of Public Project Informal Bidding Procedure.* This informal bidding procedure shall be used when a public project is involved and informal bidding is permitted by this chapter.
- B. *Distribution of Notice Inviting Informal Bids to Contractor List.* The Purchasing Officer shall provide a notice inviting informal bids not less than ten calendar days before the bids are due. The notice inviting informal bids shall be mailed or provided to all construction trade journals specified in Public Contract Code Sections 22034 and 22036.
- C. *Contents of Notice Inviting Informal Bids.* At a minimum, the notice inviting informal bids shall:
1. Describe the project in general terms;
 2. State how to obtain more detailed information about the project;
 3. State the date, time and place for the submission of sealed bids; and
 4. Include any other information required by state or local law, as determined by the City Attorney.
- D. *Proprietary Projects or Products.* If the director of the appropriate department certifies that, to the best of his or her knowledge, the product or service is proprietary in nature and can be obtained only from a limited number of contractors, and that no equivalent products or services are available, the notice inviting informal bids may be sent exclusively to such contractor or contractors.
- E. *Contents of Remaining Bid and Contract Documents.* The contents and form of the remaining bid and contract documents shall be approved by the director of the appropriate department, as well as the City Attorney.
- F. *City's Authority.* The City may reject any or all bids received, and may waive any minor irregularities in each bid received.
- G. *No Bids Received.* If no bids are received, the Authorized Contracting Party may award the contract by any alternative procedure.
- H. *Award of Contract.* The contract shall be awarded in accordance with Section 3.01.030.F. If two or more bids are the same and the lowest, the City may accept the one it chooses in its sole and absolute discretion.

(Ord. No. 1097, § 3(Exh. A), 11-21-2017)

3.01.080 - Formal bidding procedure for non-public projects.

- A. *Uses of the Non-Public Project Formal Bidding Procedure.* A formal bidding procedure shall be used whenever formal bidding is required by this chapter and the project does not involve a public project.

- B. *Distribution of Notice Inviting Formal Bids or Request for Proposals.* A notice inviting formal bids or a request for proposals, as appropriate, shall be published at least fourteen calendar days before the date of opening the bids or proposals in a newspaper of general circulation printed and published in the City, or, if there is no such newspaper, in a newspaper of general circulation which is circulated in the City. The notice inviting formal bids or request for proposals may also be provided directly to vendors or contractors. The City shall endeavor to receive formal bids or proposals from at least three vendors or contractors. A notice inviting bids shall be used whenever the project or purchase must be awarded to the lowest responsible and responsive bidder. A request for proposals may be used whenever the project or purchase is not required to be awarded to the lowest responsible and responsive bidder. If the Purchasing Officer and the director of the appropriate department certify that, to the best of their knowledge, there is no local source or local provider available for the project, the notice inviting bids or the request for proposals, as appropriate, may be distributed to a list of qualified vendors maintained by the Purchasing Officer and/or published in a trade journal appropriate to the project, in lieu of publication in a newspaper of general circulation.
- C. *Contents of Notice Inviting Formal Bids or Request for Proposals.* At a minimum, the notice inviting formal bids or request for proposals shall:
 1. Describe the project or purchase in general terms;
 2. State how to obtain more detailed information about the project or purchase;
 3. State the date, time and place for the submission of bids or proposals; and
 4. Include any other information required by state or local law, as determined by the City Attorney. Bids for purchases of more than \$175,000.00 shall be sealed bids.
- D. *Proprietary Projects or Sole Source Products.* If the director of the appropriate department certifies that, to the best of his or her knowledge, the product or service is proprietary in nature and can be obtained only from a limited number of vendors or contractors, and that no equivalent products or services are available, the notice inviting formal bids or request for proposals may be sent exclusively to such vendor(s) or contractor(s).
- E. *Contents of Remaining Bid and Contract Documents.* The contents and form of the remaining bid and contract documents shall be approved by the director of the appropriate department, as well as the City Attorney.
- F. *City's Authority.* The City may reject any or all bids or proposals received, and may waive any minor irregularities in each bid or proposal received.
- G. *No Bids Received.* If no bids are received, the Authorized Contracting Party may award the contract by any alternative procedure.

(Ord. No. 1097, § 3(Exh. A), 11-21-2017)

3.01.090 - Informal bidding procedure for non-public projects.

- A. *Uses of Non-Public Project Informal Bidding Procedure.* This informal bidding procedure shall be used whenever informal bidding is allowed for a purchase which does not involve a public project.
- B. *Distribution of Notice Inviting Informal Bids or Request for Proposals.* A Notice inviting informal bids or request for proposals, as appropriate, shall be provided. The notice inviting informal bids or requests for proposals shall be provided to at least three vendors or contractors, and the City shall endeavor to receive informal bids or proposals from at least three vendors or contractors. A notice inviting bids shall be used whenever the project or purchase must be awarded to the lowest responsible and responsive bidder. A request for proposals may be used whenever the project or purchase is not required to be awarded to the lowest responsible and responsive bidder.
- C. *Contents of Notice Inviting Informal Bids or Request for Proposals.* At a minimum, the notice inviting informal bids or request for proposals shall:

1. Describe the project or purchase in general terms;
 2. State how to obtain more detailed information about the project or purchase;
 3. State the date, time and place for the submission of bids or proposals; and
 4. Include any other information required by state or local law, as determined by the City Attorney. Bids for purchases of more than \$45,000.00 shall be sealed bids.
- D. *Proprietary Projects or Products.* If the director of the appropriate department certifies that, to the best of his or her knowledge, the product or service is proprietary in nature and can be obtained only from a limited number of vendors or contractors, and that no equivalent products or services are available, the notice inviting informal bids or request for proposals may be sent exclusively to such vendor(s) or contractor(s).
- E. *Contents of Remaining Bid and Contract Documents.* The contents and form of the remaining bid and contract documents shall be approved by the director of the appropriate department, as well as the City Attorney.
- F. *City's Authority.* The City may reject any or all bids or proposals received, and may waive any Minor irregularities in each bid or proposal received.
- G. *No Bids or Proposals Received.* If no bids or proposals are received, the Authorized Contracting Party may award the contract by any alternative purchasing procedure.

(Ord. No. 1097, § 3(Exh. A), 11-21-2017)

3.01.100 - Exceptions to competitive bidding on public projects.

In addition to the situations described in Section 3.01.030, competitive bidding, either formal or informal, is not required for public projects in the situations provided for in this section. Under such conditions, the alternative procedure may be used.

- A. *Emergencies.* In situations determined by the City Manager to constitute an emergency for repair or replacement of a public project pursuant to Public Contract Code Section 22035 and Public Contract Code Section 22050, the City Council hereby delegates to the City Manager the power to declare a public emergency and take any directly related and immediate action required by the emergency, up to a total of \$100,000.00, pursuant to California Public Contract Code Section 22035 and California Public Contract Code Section 22050. Emergency expenditures of more than \$100,000.00 shall first be approved by the City Council. Work may be performed without the benefit of competitive bidding, either formal or informal, only so long as necessary under those sections.

For projects of more than \$25,000.00, a report on the emergency and work performed shall be provided at the next regular meeting of the City Council, and then at every meeting thereafter required by California Public Contract Code Section 22050. At such meetings, the City Council shall determine, by a four-fifths vote, that there is a need to continue the action without the benefit of informal or formal competitive bidding in accordance with California Public Contract Code Section 22035 and California Public Contract Code Section 22050. The City Council shall terminate the emergency action at the earliest possible date that conditions warrant, so that the remainder of the emergency action may be completed pursuant to a formal bidding procedure or other applicable procedure.

For projects of \$25,000.00 or less, the City Manager shall determine, on his or her own as the action continues, whether there is a need to continue the action without the benefit of the applicable bidding procedure. The City Manager shall terminate the emergency action at the earliest possible date that conditions warrant, so that the remainder of the emergency action may be completed pursuant to the applicable bidding procedure.

- B. *No Competitive Market.* When the City Council determines, in accordance with applicable law, that a competitive market does not exist and that no competitive advantage will be gained by the public bidding process.
- C. *No Bids Received.* When no bids are received pursuant to either the public project informal bidding procedure or the public project formal bidding procedure the Purchasing Officer may proceed by the alternative procedure.
- D. *Otherwise Authorized.* When otherwise authorized by this chapter or applicable law including, but not limited to Public Contract Code Section 22160 et seq. concerning design build.

(Ord. No. 1097, § 3(Exh. A), 11-21-2017)

3.01.110 - Exceptions to competitive bidding on non-public projects.

In addition to the situations described in Sections 3.01.090 through 3.01.100, competitive bidding, either formal or informal, is not required for non-public projects in the situations provided for in this section. Under such conditions, any alternative procedure, including no bidding, may be used with the City Manager's approval.

- A. *Emergencies.* In situations determined by the Authorized Contracting Party to constitute an emergency, as defined in Section 3.01.010.
- B. *No Competitive Market.* When the City Council determines, in accordance with applicable law, that a competitive market does not exist and that no competitive advantage will be gained by the public bidding process.
- C. *Competitive Bidding Already Completed.* When the Authorized Contracting Party determines that a competitive bid procedure has been conducted by another public agency (e.g. through CMAS or GSA) and the price to the City is equal to or better than the price to that public agency.
- D. *State Purchase.* When the purchase is made on behalf of the City by the State Department of General Services.
- E. *Purpose of Bidding is Otherwise Accomplished.* When the City Manager determines that it is in the best interest of the City and its administrative operations to dispense with public bidding for non-public projects under this chapter. Prior City Council concurrence with the City Manager's determination shall be required for non-public project purchases over \$100,000.00.
- F. *No Bids Received.* When no bids are received non-public project formal or informal bidding procedures.
- G. *Expenses.* The reimbursement or payment of travel expenses and other employee expenses.
- H. *Insurance.* The payment of any insurance premiums or claims, including employee medical payments.
- I. *Real Property.* The purchase or lease of real property with City Council approval.
- J. *Banking.* Banking services.
- K. *Otherwise Authorized.* When otherwise authorized by this chapter or applicable law.

(Ord. No. 1097, § 3(Exh. A), 11-21-2017)

3.01.120 - City Manager authorization to execute contracts.

Pursuant to the California Government Code, the Mayor must execute all contracts on behalf of the City, unless another City officer or employee is authorized to do so. The City Manager and his or her

designees, as explicitly set forth in this chapter and the administrative policies implementing this chapter, are hereby authorized to execute contracts on behalf of the City.

(Ord. No. 1097, § 3(Exh. A), 11-21-2017)

Staff Report

TO: Mayor and City Council Members
FROM: Thaxton Van Belle, Chief Plant Operator
DATE: May 21, 2019
SUBJECT: Approval for Purchase of Model 742 JLG Multipurpose Telehandler

Background and Analysis:

A telehandler is a versatile piece of equipment that can act as a manlift, crane, forklift, loader, and more. The Wastewater Department requests the purchase of a multipurpose telehandler with bucket, forks, and manlift attachments for use at the wastewater plant and lift stations.

Regular, routine uses include lifting and maneuvering very large and bulky items like chemicals and equipment. Additionally, the telehandler would be used for major system repairs such as removing and replacing lift station pumps. It is an important item for normal operations and provides a safer way of loading centrifuge solids evenly into trailers from a distance, and as a manlift to service elevated equipment such as bar-screens, conveyors, centrifuges, some radio equipment.

Past practice has been to rent a telehandler for each and every occurrence of the above scenarios at a daily rate of \$275 plus \$100 trailered delivery and pick up. This mode of operation is not only costly, but limits availability of the equipment.

Several quotes were obtained from various manufactures of similarly rated telehandlers (attached). Staff selected the JLG model 742 based on needs, pricing, and availability. The model 742 has a rated capacity of 7,000 lbs and a reach of 42 feet. West Coast Equipment, LLC has a unit in stock and available for local purchase.

Fiscal Impact:

The total cost for purchasing the JLG 742 telehandler with attachments is \$101,102.02 and will be funded from Account # 700-4050-8040-0000.

Finance Director Review: _____

Recommendation:

1. Approve the purchase of a JLG 742 telehandler with forks, 1.5 yard bucket, and 4 x 8 man basket not to exceed the amount of \$101,102.02 from West Coast Equipment, LLC.

City Manager Review: 

Attachments:

- A. JLG 742 Quote
- B. Skytrak 8042 Quote
- C. CAT TL642D Quote
- D. Xtreme XR742 Quote
- E. Typical Use Photos

Attachment A
JLG 742



Performance

Rated Capacity	7,000 lb	3,175 kg
Maximum Lift Height	42 ft	12.8 m
Load at Max Height	6,000 lb	2,722 kg
Maximum Forward Reach	29 ft 1 in.	8.86 m
Load at Max Reach	1,000 lb	454 kg
Frame Leveling	10°	
Lift Speed (boom retracted)		
Up	11.3 sec	
Down	9 sec	
Boom Speed		
Extended	11 sec	
Retracted	11.5 sec	
Top Travel Speed (4-Speed)	18 mph	29 kph
Drawbar Pull (loaded)	19,000 lb	84.5 kN
Outside Turning Radius	12 ft	3.66 m
Operating Weight	21,476 lb	9,741 kg

Standard Specifications

Engine

Make and Model	Cummins QSF3.8L Tier 4 F	
No. of Cylinders	4	
Displacement	232 cu in.	3.8 L
Gross Power Basic	74 hp	55 kW
Maximum Torque @ 2,500 rpm	295 lb-ft	400 Nm
Fuel Tank Capacity	38.3 gal	145 L

Transmission

Powershift 4-speed forward and 3-speed reverse.

Axles

Trunnion mounted planetary steer axles. Integral steer cylinder. High bias limited slip differential on front axle.

Brakes

Service brakes are inboard wet disc brake on front and rear axles. Parking brakes are wet disc spring-applied hydraulic release on front axle.

Tires

Standard	370/75-28
Optional	Foam-Filled or Solid

Cab

- Certified ROPS/FOPS structure
- Horn
- Tilt & declutch on joystick
- Adjustable seat
- Single joystick controls
- Anti-theft

Steering 4-Wheel

Power steering with manual backup. Operator selectable 4-wheel circle, 4-wheel crab, 2-wheel front.

Instruments

- Volt meter
- Engine oil pressure gauge
- Fuel gauge
- Hourmeter
- Temperature gauge
- DEF gauge

Hydraulic System-Implement

Capacity	40 gal	151.5 L
----------	--------	---------

Piston pump. Auxiliary hydraulics used for all attachments equipped with cylinders or other hydraulic components.

Accessories & Options

- Enclosed Cab
- Auxiliary Electrics
- Road Lights
- Air Conditioning
- Work Lights
- Rotating Beacon
- Hydraulic Coupler
- Fenders
- Brick Guards
- Arctic Package
- Multi-Function Display with Reversing Camera
- Ride Control
- Reverse Sensing System
- Boom Brushes
- Secondary Steering
- Wiper Package
- White Noise Backup Alarm
- 110 hp (83 kW) Tier 4 Final Engine

Attachments

Standard Carriage	50 in. 60 in. 72 in.	1.3 m 1.5 m 1.8 m
Side-Tilt Carriage	50 in. 60 in. 72 in.	1.3 m 1.5 m 1.8 m
Swing 90° Carriage	72 in.	1.8 m
Dual Fork Positioning Carriage	50 in.	1.3 m
Side-Shift Carriage	50 in.	1.3 m
Tower	8 ft	2.4 m
Tower with Side Tilt	8 ft	2.4 m
Pallet Forks	2.36 in. x 4 in. x 48 in. 2.36 in. x 5 in. x 48 in. 2.00 in. x 6 in. x 72 in.	60 mm x 102 mm x 1.2 m 60 mm x 127 mm x 1.2 m 51 mm x 152 mm x 1.8 m
Lumber Forks	2.00 in. x 7 in. x 60 in. 2.36 in. x 6 in. x 60 in.	51 mm x 178 mm x 1.5 m 60 mm x 152 mm x 1.5 m
Cubing Forks	2 in. x 2 in. x 48 in.	51 mm x 51 mm x 1.2 m
Fork Extensions	90 in.	2.3 m
Material Bucket	72 in., 1.0 cu yd 96 in., 1.5 cu yd 102 in., 2.0 cu yd	1.8 m, 0.76 m³ 2.4 m, 1.15 m³ 2.6 m, 1.53 m³
Fork-Mounted Bucket	60 in., 1.0 cu yd 2,000 lb Capacity	1.5 m, 0.76 m³ 907 kg Capacity
Grapple Bucket	96 in., 1.75 cu yd	2.4 m, 1.34 m³
Truss Boom	3 ft (winch), 4,000 lb Capacity	0.9 m, 1,814 kg Capacity
Truss Boom	12 ft, 2,000 lb 15 ft, 2,000 lb 12 ft with winch, 2,000 lb	3.7 m, 907 kg 4.6 m, 907 kg 3.7 m, 907 kg
Fork Mounted Work Platform	8 ft, 1,000 lb Capacity	2.4 m, 455 kg Capacity
Material Handling Arm	4,000 lb Capacity	1,814 kg Capacity
Trash Hopper	72 in., 1.9 cu yd	1.8 m, 1.5 m³
Sweeper	105 in., 53 cu yd 1,717 lb Capacity	2.67 m, 0.41 m³ 779 kg Capacity

Lifting Hook-Fork Mounted
Lifting Hook-Coupler Mounted

742

TELEHANDLER



Dimensions

All dimensions are approximate.

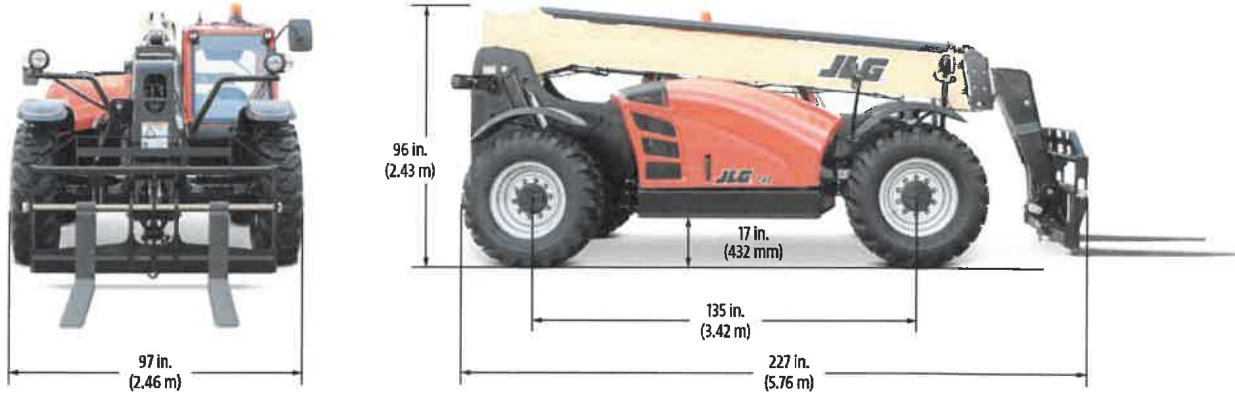

Load Chart

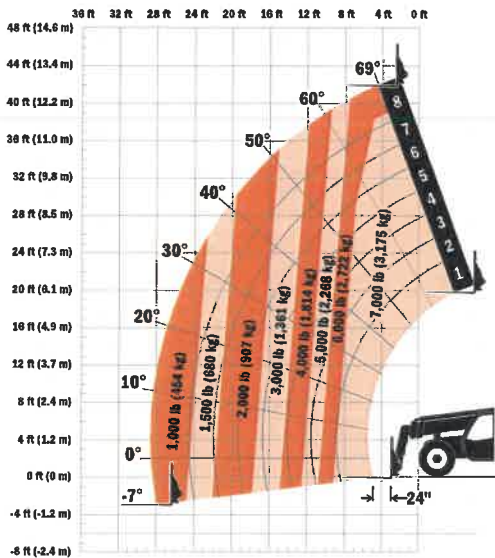

The JLG "1 & 5" Warranty

JLG Industries, Inc. backs its products with its exclusive "1 & 5" Warranty. We provide coverage on all products for one (1) full year, and cover all specified major structural components for five (5) years. Due to continuous product improvements, we reserve the right to make specification and/or equipment changes without prior notification. This machine meets or exceeds applicable OSHA Regulations in 29 CFR 1910.67, 29 CFR 1926.453, ANSI A92.5-2006, and CSA Standard CAN3-B354.2-M82, as originally manufactured for intended applications.

Part No.: 3132247
Printed in USA

JLG Industries, Inc.
1 JLG Drive
McConnellsburg, PA 17233-9533
Telephone 717-485-5161
Toll-free in US 877-JLG-LIFT
Fax 717-485-6417
www.jlg.com
An Oshkosh Corporation Company



Quote #: q3489
 P.O. Box 31001-2584
 Pasadena, Ca 91110-2584
 www.westcoastequipment.us
 951-256-2040 Phone
 951-848-0843 Fax
 Status: Quote
 Quoted: Thu 5/16/2019 9:00AM

Customer #: 4474
 951-769-8520 Phone
 City of Beaumont
 550 E. 6th Street
 Beaumont, CA 92223

Job Descr: Quote for new JLG 742 Telehandler

Salesman: Tony Cerone tony@westcoastequipment.us
 Kevin 909-725-5047
 JLG 742
 work light kit
 reverse sensing
 standard carriage with 48 inch fork
 Air filled tire

** 5-16-19 UNIT IS GOOD IN STOCK IN CORONA **

Qty	Key	Items Sold	Ser#	Each	Price
1	MS SNT	Misc Sales New Telehandler		\$85,500.00	\$85,500.00
		JLG 742 w / air tires			
		"When operated in California, any off-road diesel vehicle may be subject to the California Air Resources Board In-Use Off-road Diesel Vehicle Regulation. It therefore could be subject to retrofit or accelerated turnover requirements to reduce emissions of air pollutants. For more information, please visit the California Air Resources Board website at http://www.arb.ca.gov/msprog/ordiesel/ordiesel.htm ."			
1	FRT	Freight		\$2,500.00	\$2,500.00
		FOB Factory to Corona			
1	MS Parts	Sales Item, Misc		\$3,810.00	\$3,810.00
		1.5 yd bucket			
1	MS Parts	Sales Item, Misc		\$2,200.00	\$2,200.00
		4 x 8 man basket			

Quote

Quote

This is a Quote Only

Sales:	\$94,010.00
Subtotal:	\$94,010.00
Riverside - Corona:	\$7,092.02
Total:	\$101,102.02
Paid:	\$0.00
Amount Due:	\$101,102.02

Attachment B
Skytrak 8042

Performance

Rated Capacity	8,000 lb	3,629 kg
Maximum Lift Height	41 ft 11 in.	12.8 m
Load at Max Height	6,000 lb	2,722 kg
Maximum Forward Reach	26 ft 7 in.	8.10 m
Load at Max Reach	2,200 lb	998 kg
Frame Leveling	10°	
Lift Speed (boom retracted)		
Up	15 sec	
Down	13 sec	
Boom Speed		
Extended	16.5 sec	
Retracted	14.2 sec	
Top Travel Speed (4-Speed)	19 mph	31 kph
Drawbar Pull (loaded)	25,000 lb	111 kN
Outside Turning Radius	13 ft	4.0 m
Operating Weight	27,100 lb	12,242 kg

Standard Specifications

Engine

Make and Model	Cummins QSF3.8L Tier 4 F	
No. of Cylinders	4	
Displacement	229 cu in.	3.8 L
Gross Power Basic	110 hp	82 kW
Maximum Torque @ 1500 rpm	348 lb-ft	472 Nm
Fuel Tank Capacity	35 gal	132.5 L

Transmission

Powershift.
4-speed forward and 3-speed reverse.

Axles

Full-time planetary 4-wheel drive.
Oscillating rear axle with Stabil-Trak system.

Brakes

Hydraulically actuated inboard wet disc brakes.
Emergency brake with transmission declutch feature.

Tires

Standard	370/75-28
Optional	Foam-Filled or Solid

Cab

Certified ROPS/FOPS structure.	Single joystick controls.
Adjustable suspension seat with retractable seat belt.	Integrated arm rest. Rear view mirrors.

Steering 4-Wheel

Power steering.
Operator selectable 4-wheel circle, 4-wheel crab, 2-wheel front.

Instruments

• Hourmeter	• Engine Oil Pressure Gauge
• Voltmeter	• DEF Gauge
• Temperature Gauge	• Fuel Gauge



Hydraulic System-Implement

Capacity	45.5 gal	172.2 L
----------	----------	---------

Piston pump.
Variable flow, load sensitive hydraulic system.
Load holding valves on frame level, stabilizer, attachment tilt, extend and lift cylinders.
Auxiliary hydraulics used for all attachments equipped with cylinders or other hydraulic components. Consists of valves, controls and hydraulic lines.

Accessories & Options

- Enclosed Cab
- Work Lights
- Road Lights
- Air Conditioning
- Rotating Beacon
- Fenders
- Reverse Sensing System
- 74 hp (55 kW) Tier 4 Final Engine

Attachments

Standard Carriage	50 in. 60 in. 72 in.	1.3 m 1.5 m 1.8 m
Side-Tilt Carriage	50 in. 60 in. 72 in.	1.3 m 1.5 m 1.8 m
Swing 90° Carriage	72 in.	1.8 m
Side-Shift Carriage	50 in.	1.3 m
Dual Fork Positioning Carriage	50 in.	1.3 m
Tower	8 ft (2.4 m); 50 in. (1.3 m) Standard Carriage	
Pallet Forks	2.36 in. x 4 in. x 48 in. 2.36 in. x 5 in. x 48 in. 2.00 in. x 6 in. x 72 in.	60 mm x 102 mm x 1.2 m 60 mm x 127 mm x 1.2 m 51 mm x 152 mm x 1.8 m
Lumber Forks	2.00 in. x 7 in. x 60 in. 2.36 in. x 6 in. x 60 in.	51 mm x 178 mm x 1.5 m 60 mm x 152 mm x 1.5 m
Cubing Forks	2 in. x 2 in. x 48 in.	51 mm x 51 mm x 1.2 m
Fork Extensions	90 in.	2.3 m
Material Bucket	72 in., 1.0 cu yd 96 in., 1.5 cu yd 102 in., 2.0 cu yd	1.8 m, 0.76 m³ 2.4 m, 1.15 m³ 2.6 m, 1.53 m³
Grapple Bucket	96 in., 1.75 cu yd	2.4 m, 1.34 m³
Truss Boom	12 ft, 2,000 lb 15 ft, 2,000 lb 12 ft with winch, 2,000 lb	3.7 m, 907 kg 4.6 m, 907 kg 3.7 m, 907 kg
Fork Mounted Work Platform	8 ft, 1,000 lb Capacity	2.4 m, 455 kg Capacity
Lifting Hook, Fork Mounted		
Material Handling Arm	4,000 lb Capacity	1,814 kg Capacity
Trash Hopper	72 in., 1.9 cu yd 2,000 lb Capacity	1.8 m, 1.5 m³ 907 kg Capacity

8042

TELEHANDLER

SKYTRAK

Dimensions

All dimensions are approximate.



Load Chart

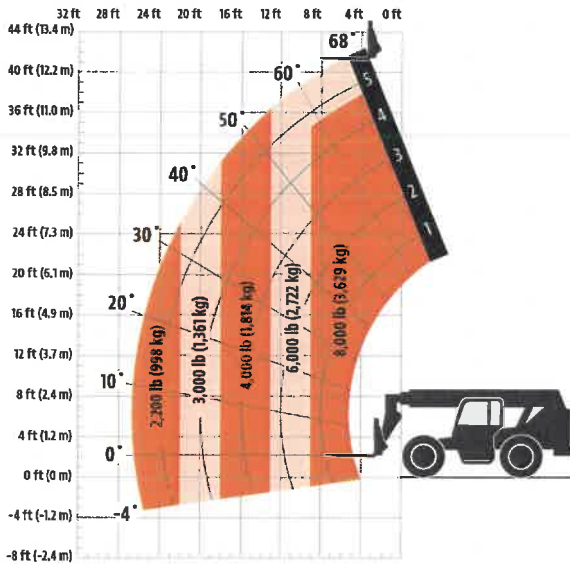

The JLG "1, 2 & 5" Warranty

We provide coverage for one (1) full year on the entire machine, two (2) full years or 2,000 hours on the drivetrain and cover all specified major structural components for five (5) years. Due to continuous product improvements, we reserve the right to make specification and/or equipment changes without prior notification.

Part No.: 3132400
R011811
Printed in USA



JLG Industries, Inc.
1 JLG Drive
McConnellsburg, PA 17233-9533
Telephone 717-485-5161
Toll-free in US 877-JLG-LIFT
Fax 717-485-6417
www.jlg.com
An Oshkosh Corporation Company



Quote #: q3488
 P.O. Box 31001-2584
 Pasadena, Ca 91110-2584
 www.westcoastequipment.us
 951-256-2040 Phone
 951-848-0843 Fax
 Status: Quote
 Quoted: Tue 3/ 5/2019 9:00AM

Customer #: 4474
 951-769-8520 Phone
 City of Beaumont
 550 E. 6th Street
 Beaumont, CA 92223
 Job Descr: Quote for Skytrak 8042

Salesman: Tony Cerone tony@westcoastequipment.us
 Chris 951-769-8520
 2019 SKYTRAK 8042
 Standard Features:
 ••Cummins QSF 3.8L 74 hp Tier 4 Final Turbo Diesel Engine
 ••4-Wheel Drive
 ••±10 degrees Frame Leveling
 ••Three Steering Modes
 ••Modulated Powershift, 4-Speed Forward and 3-Speed Reverse
 Air filled tires
 72 inch carriage & 48 inch forks
 Work light kit

Qty	Key	Items Sold	Ser#	Each	Price
1	MS SNT	Misc Sales New Telehandler		\$101,273.00	\$101,273.00
		2019 SKYTRAK 8042 "When operated in California, any off-road diesel vehicle may be subject to the California Air Resources Board In-Use Off-road Diesel Vehicle Regulation. It therefore could be subject to retrofit or accelerated turnover requirements to reduce emissions of air pollutants. For more information, please visit the California Air Resources Board website at http://www.arb.ca.gov/msprog/ordiesel/ordiesel.htm ."			
1	FRT	Freight		\$3,250.00	\$3,250.00
		FOB FACTORY TO CORONA			

Quote

Quote

This is a Quote Only

Sales:	\$104,523.00
Subtotal:	\$104,523.00
Riverside - Corona:	\$7,848.66
Total:	\$112,371.66
Paid:	\$0.00
Amount Due:	\$112,371.66

Attachment C
CAT TL642D



Cat[®] TL642D

TELEHANDLER WITH STABILIZERS

Specifications

Engine

Model*	Cat [®] C3.4B	
Gross Power (Basic)	75 kW	100 hp

*Meets U.S. EPA Tier 4 Final emission standards.

Weights

Operating Weight	10 400 kg	22,928 lb
------------------	-----------	-----------

Operating Specifications

Rated Load Capacity	2948 kg	6,500 lb
Maximum Lift Height	12.8 m	42 ft
Maximum Forward Reach	9.1 m	30 ft
Frame Leveling	10°	
Top Travel Speed	32 km/h	20 mph
Capacity at Max Height (o/r Up)	2722 kg	6,000 lb
Capacity at Max Height (o/r Down)	2949 kg	6,500 lb
Capacity at Max Reach (o/r Up)	272 kg	600 lb
Capacity at Max Reach (o/r Down)	771 kg	1,700 lb
Turning Radius over Tires	3.7 m	12 ft
Drawbar Pull (Loaded)	88 kN	19,783 lbf

Hydraulic System

Gear Pump	Single-section	
System Operating Pressure	260 bar	3,770 psi
Auxiliary Hydraulic Pressure	240 bar	3,481 psi
Auxiliary Hydraulic Flow	68 L/min	18 gal/min

• Auxiliary Hydraulic Circuit used for all attachments equipped with cylinders or other hydraulic components.

Service Refill Capacities

Fuel Tank	145 L	38.3 gal
Hydraulic System	158 L	42 gal
Diesel Exhaust Fluid (DEF) Tank	21.5 L	5.7 gal

Tires

Standard	370/75-28 Air Duraforce	
Optional	370/75-28 Foam Duraforce	
	13.00 × 24-16 PR Air	
	13.00 × 24-12 PR Foam Filled	
	13.00 × 24 Solid	

Transmission Speeds

Forward	4 speed
Reverse	3 speed

Boom Performance

Boom Up	15.5 Seconds
Boom Down	10.7 Seconds
Tele In	11.8 Seconds
Tele Out	17 Seconds

Axles

- Trunnion mounted planetary 55 degree steer axles.
- High bias limited slip differential on front axle.

Brakes

- Service Brakes are inboard wet disc brakes on front and rear axles.
- Parking Brakes are wet disc, spring applied hydraulic release on front axle.

Work Tools

	Includes Auxiliary Electrics	Includes Auxiliary Electrics
Hydraulic IT Coupler	(2) 1220 mm, 60 mm × 125 mm	(2) 48 in, 2.36 in × 5 in
Pallet Forks	(2) 1220 mm, 60 mm × 100 mm (2) 1525 mm, 60 mm × 150 mm	(2) 48 in, 2.36 in × 4 in (2) 60 in, 2.36 in × 6 in
Lumber Forks	(2) 1525 mm, 45 mm × 180 mm (2) 1829 mm, 50 mm × 150 mm	(2) 60 in, 1.75 in × 7 in (2) 72 in, 2 in × 6 in
Cubing Forks	(2) 1220 mm, 50 mm × 50 mm	(2) 48 in, 2 in × 2 in
Carriages:		
Standard Tilt	1270 mm	50 in
Wide Tilt	1829 mm	72 in
Side Shift	1220 mm	48 in
Standard Rotate	1270 mm	50 in
Wide Rotate	1829 mm	72 in
Swing	100°, 1829 mm, 2948 kg Capacity, 2268 kg Swung	100°, 72 in, 6,500 lb Capacity, 5,000 lb Swung
Dual Fork Positioning	1270 mm	50 in



TL642D Telehandler with Stabilizers

Dimensions (All dimensions are approximate.)

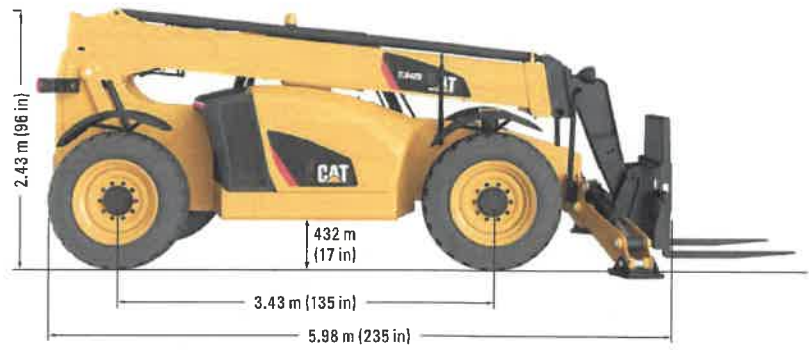
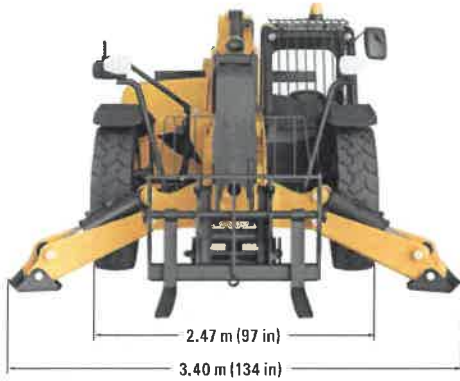

Load Chart and Dimensions

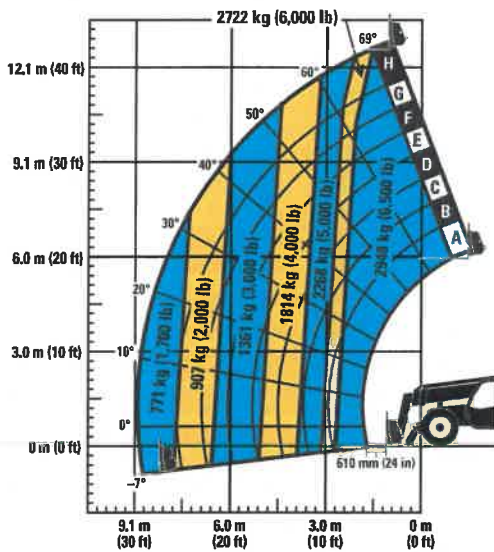

Stabilizers Down

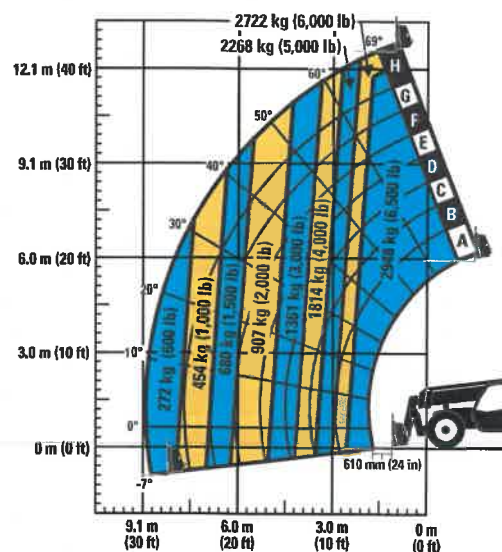

Stabilizers Up

IMPORTANT

Rated lift capacities shown are with machine equipped with carriage and pallet forks. The machine must be level on a firm surface with undamaged, properly inflated tires. Machine specifications and stability are based on rated lift capacities at specific boom angles and boom lengths. (If specifications are critical, the proposed application should be discussed with your dealer.)

DO NOT exceed rated lift capacity loads, as unstable and dangerous machine conditions will result.

DO NOT tip the machine forward to determine the allowable load.

Use only approved attachments with proper material handler model/attachment load capacity charts displayed in the operator's cab. OSHA requires all rough

terrain forklift operators be trained according to OSHA 29 CFR 1910.178 (1).

Due to continuous product improvements, machine specifications and/or equipment changes may be made without prior notification. This machine meets or exceeds ANSI/ITSDF B56.6-2011 as originally manufactured for intended applications.

For more complete information on Cat products, dealer services, and industry solutions, visit us on the web at www.cat.com

AEHQ7634 (11-2015)

© 2015 Caterpillar
All rights reserved

Materials and specifications are subject to change without notice. Featured machines in photos may include additional equipment. See your Cat dealer for available options.

CAT, CATERPILLAR, SAFETY.CAT.COM, their respective logos, "Caterpillar Yellow" and the "Power Edge" trade dress, as well as corporate and product identity used herein, are trademarks of Caterpillar and may not be used without permission.





Quote 131300-01

March 6, 2019

CITY OF BEAUMONT
Attention: Account Payable
550 E 6TH STREET
BEAUMONT
California
92223-2218
Source well MEMBER #: 130043



Dear Sir,

We would like to thank you for your interest in our company and our products, and are pleased to quote the following for your consideration.

CATERPILLAR INC. Model: TL642D TeleHandler ETA 10-12 Months

We wish to thank you for the opportunity of quoting on your equipment needs. This quotation is valid for 30 days, after which time we reserve the right to re-quote. If there are any questions, please do not hesitate to contact me.

Sincerely,

Jose Farias
Machine Sales Representative
760-399-6404

CATERPILLAR INC. Model: TL642D TeleHandler

STANDARD EQUIPMENT

CONSIST NOTE

The Standard Equipment listing is a description of a TL642D TELEHANDLER equipped with all lowest charged items.

BOOMS, STICKS AND LINKAGES

Three section boom with non-metallic wear pads Automatic vertical lift

POWERTRAIN

USA, CANADA, PUERTO RICO	Dual element air filter
-CAT C3.4B,75kW (100.6 hp)Tier 4f Engine	Spin on engine oil filter
SOUTH AMERICA (EXCEPT PUERTO RICO)	Spin on Hydraulic oil filter
-CAT C3.4B,75kW (100.6HP) Tier 3 Engine	Planetary drive axles with full time
4 Speed Powershift Transmission	four wheel drive
Hydraulically driven fan	Limited slip differential
Radiator Cores	Wet disc service brakes
Side by side engine air	Spring Applied Hydraulic Release (SAHR)
Engine oil	park brake w/indicator light
Hydraulic oil and coolant	Thermal starting aid
Water separator	

HYDRAULICS

Gear pump	carrying cylinders
- Max Auxiliary Flow: 18gpm	Auxiliary hydraulic service on the
- System Operating Pressure: 260 bar	boom head - single function
- Auxiliary Oprating Pressure: 240 bar	CAT XT3 hoses, couplings
Load hold check valves on all load	

ELECTRICAL

12 volt electrical socket	1000 CCA maintenance-free battery
75 ampere alternator	Horn + Standard Back up alarm

OPERATOR ENVIRONMENT

Operator station isolated on rubber mounts	Seat belt and document pouch
Boom joystick	Left and right-side rear-view mirror
Stabilizer levers	Power steering with steering wheel
Frame level switch	Load charts
Fully adjustable vinyl suspension seat	Heavy duty floor mat
	Fuse panel

OTHER STANDARD EQUIPMENT

Integral lift and tie-down points

INSTRUCTIONS

Operation and maintenance manual

MACHINE SPECIFICATIONS

Description	Reference No	List Amount
TL642D TELEHANDLER HRC	483-9505	\$135,680.00
LANE 3 ORDER	0P-9003	
CLIMATE PACK, STANDARD	486-3403	
CANOPY, OPEN	484-1909	
BELT, SEAT, 3"	470-0859	\$98.00
MONITOR, NONE	476-5226	
ALARM, BACK UP, STANDARD	485-3311	
TIRES, 13.00-24, CAT, G2	487-7045	\$575.00
FENDER, CANOPY, SINGLE	486-3475	
COUPLER, MANUAL, IT	484-6334	
LOADCHART (AM-N), STANDARD	512-0492	
TL642D NORTH AMERICAN ORDER	0P-3917	
INSTRUCTIONS, ANSI	483-7766	
MANUAL, OPER. MAINT. ENGLISH	487-7066	
PRODUCT LINK READY	501-3003	\$258.00
LIGHTS,ROADING,RH,N/STABILIZER	482-6431	\$1,670.00
CARRIAGE, STANDARD 60"	476-5227	\$2,153.00
PACK, ROLL ON/ROLL OFF, TL	0P-3714	
LEVER, MANUAL, FNR/WIPERS/IND	472-7832	
ROOF CAP	474-6078	\$173.00
RIDE CONTROL, NONE	565-5007	
PREPARATION PACK, AM-N	568-7349	
FRAME, STABILIZER	485-1070	\$9,290.00
FORK, PALLET 2.36" X 4" X 48"	301-9755	\$2,228.00
BUCKET, GP 1.31 CYD	163-4261	\$4,372.00

Sell Price	\$156,497.00
<i>Sourcewell DISCOUNT (24%)</i>	<i>(\$37,559.28)</i>
Net Balance Due	\$118,937.72
CA SALES TAX (7.75%)	\$9,217.67
After Tax Balance	\$128,155.39

Source well Contract Number 032515-CAT

WARRANTY

Standard Warranty: 12 Months Full Machine

F.O.B/TERMS

Riverside Machine

FINANCING

Finance terms and conditions subject to credit approval by Caterpillar Financial Services Inc.(CFSC). Payment amounts, down payments, and terms are estimates only, final amounts must be determined by CFSC.

ADDITIONAL CONSIDERATIONS

- Delivery is 10-12 Months ETA

Accepted by _____ on _____

Signature

Attachment D
Xtreme XR742



Diamond A Equipment Sales Proposal

821 N Rice Avenue, Oxnard CA 93030 • 1306 White Court, Santa Maria CA 93458
 2635 E South Street, Long Beach CA 90805 • 10232 Glenoaks Blvd, Picoima CA 91331



Assembly Request Delivery Request Pick-Up Request Demo Return Date _____

Customer: The City Of Beaumont **Date:** 5/14/09
Contact: Kevin Lee **Phone:** 1909 **Customer P.O. #:** _____
Address: Water Basin Plant 714 Fourth St **City:** Beaumont **Sales Rep:** Joe Beeson
State: CA **Zip:** _____ **Cell #:** 562 537 2822

Status		Service Items		Service Items		Service Items	
<input type="checkbox"/> Sold	<input type="checkbox"/> Stock	<input type="checkbox"/> Water in tires	<input type="checkbox"/> Tire Spacing _____"	<input type="checkbox"/> GPS	<input type="checkbox"/> Top N Tilt		
<input type="checkbox"/> Rental	<input type="checkbox"/> Trade In	<input type="checkbox"/> Canopy	<input type="checkbox"/> Radio	<input type="checkbox"/> Drawbar	<input type="checkbox"/> Other		
<input type="checkbox"/> Transfer	<input type="checkbox"/> Demo	<input type="checkbox"/> Lights	<input type="checkbox"/> Weights _____	<input type="checkbox"/> Hammerstrap			

Tractors & Equipment

Make	Model #	Description	Serial #	Stock #	Hours	Amount
Extreme	XR742 Open Cab	Telehandler			List Price	\$ 175,704.00
		Cummins 3.8 I 120 hp Tier 4 Diesel Engine				
		ZF3WG94 Transmission				
		ZF MST3055/3060 Axles				
		Steering - 4 Wheel Circle, Crab, 2 Wheel Front Back Up Alarm				
		Quich Attach (Common Fit) Xtreme Service Accessibility Engine Block Heater				
		8,000lb Max Lift Capacity 26,850lbs. Operating Weight 42' Max Lift Height				
		11 Degrees Frame Leveling L/R 28'10" Max Forward Reach				
		Machine Rated Lifting Point STANDARD				
		Heavy Duty Frame/Chassis and Roller Boom Melonite Pins and Rollers				
		Auxiliary Hydraulics Direct Dual Control Hydraulic Valve Actuation				
	Attachment	1.0 cu yard Bucket				
	Attachment	Platform Personnel Cage 6' X 4"				
		10 Year or 10,000 hrs Main frame & Chassis Assembly				
		5 year or 5000 Hours Boom/Roller Assembly				
		2 Year or 2000 hrs Power train Engine Transmission Drive axle				
		& Hydraulic components				
		Diamond A /Xtreme Discount				(\$ 39,900.00)

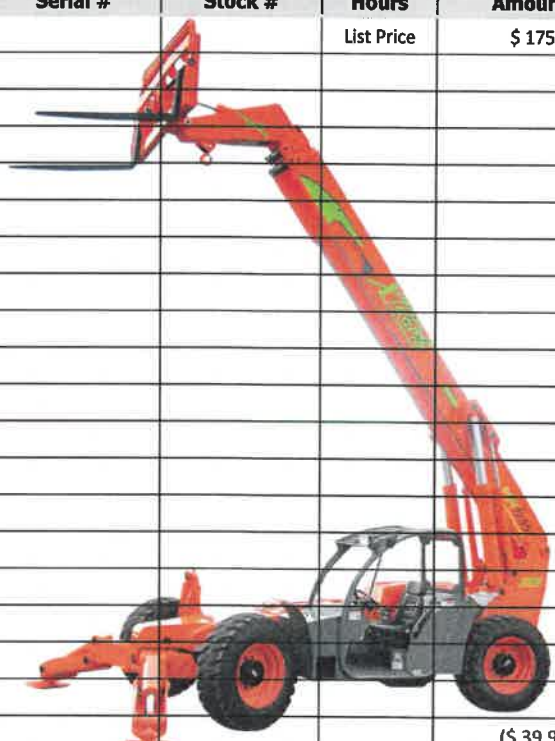

Assembly Instructions

Municipal Discount reflected in quote (steel Tax Included)
 Government Entities receive ON line Support and IN Person Training
 Warranty list in body.

 When approved P.O. is required along with signed quote.

Totals

Selling Price:	\$ 135,804.00
Tax:	\$ 10,524.81
Total:	\$ 146,328.81
Trade In:	
Freight:	
Cash/Down Payment:	
Balance:	

Customer Signature: _____

Date: _____

Sales Representative: Joe Beeson _____

Date: 3/19/2019 _____

Attachment E
Xtreme XR742





Staff Report

TO: Mayor and City Council Members

FROM: Nicole Wheelwright, Deputy City Clerk

DATE: May 21, 2019

SUBJECT: Authorize Mayor Julio Martinez to Travel to Sacramento to Attend the Environmental Quality Policy Committee

Background and Analysis:

Mayor Julio Martinez is a member of the Environmental Quality Policy Committee which reviews issues related to air and water quality, and other related topics. The committee meets quarterly, with its next meeting being June 13, 2019, in Sacramento. Mayor Julio Martinez requests authorization to attend the next scheduled meeting.

Travel authorization is requested for an overnight stay and associated authorized expenses. It is estimated that total cost for the trip will not exceed \$750.

Fiscal Impact:

Hotel, meal allowance, parking, mileage, airfare and miscellaneous fees are estimated to be \$750 for the committee meeting.

Finance Director Review: _____

Recommendation:

Consideration and review of travel request.

City Manager Review:  _____

Attachments:

- A. Environmental Quality Policy Committee background information

[Home](#) > [Policy & Advocacy](#) > [Policy Committees](#) > Environmental Quality Policy Committee

Environmental Quality Policy Committee

The Environmental Quality Policy Committee reviews issues related to air and water quality, CEQA, integrated waste management, hazardous materials, coastal issues, and utilities.

[Meetings](#)

[Agendas & Highlights](#)

[Committee Roster](#)

[Resources](#)



Policy committees generally meet quarterly. The 2019 Environmental Quality Policy Committee meetings are as follows:

- Thursday, January 17 - Sacramento
- Thursday, March 28 - Costa Mesa
- Thursday, June 13 - Sacramento

Meetings begin at 10:00 a.m. and end by 3:00 p.m.

[Terms of Use](#)

© 2019 League of California Cities

[New Privacy Policy](#)

ENVIRONMENTAL QUALITY POLICY COMMITTEE

Thursday, January 17, 2019

10:00 a.m. – 3:00 p.m.

Sacramento Convention Center, 1400 J Street, Room 203, Sacramento CA 95814

A G E N D A

SPECIAL ORDER: State Budget and Issues Briefing for all policy committee members
10:00 – 10:45 a.m., Room 204, Sacramento Convention Center
Upon adjournment, individual policy committee meetings will begin

- I. Welcome and Introductions**
- II. Public Comment**
- III. Overview of Parliamentary Procedure and Roberts Rules (Attachment A)** *Informational*
- IV. Committee Orientation (Attachment B)** *Informational*
- V. League Strategic Goals for 2019 (Attachment C)** *Informational*
Learn about the League’s 2019 strategic goals, as developed by League Leaders.
- VI. Review of Existing Policy & Guiding Principles (Attachment D)** *Informational*
- VII. 2019 Draft Work Program (Attachment E)** *Action*
Set priorities for 2019 to inform the issues of focus for guest speakers and legislation.
- VIII. California Department of Conservation** *Informational*
Speakers: David Bunn, Director
Sarah Rubin, Outreach and Engagement Coordinator
Hear from the Department of Conservation about mapping and other tools available to cities for disaster preparation, planning, and response.
- IX. Institute for Local Government** *Informational*
Speakers: Christal Love Lazard, Program Manager
Karalee Browne, Program Manager
ILG staff will discuss new state funding to provide technical assistance for sustainability to local agencies.
- X. Legislative Update (Attachment F)** *Informational*
 - 1. Legislative process
 - 2. Update on introduced legislation
 - 3. Food packaging

Next Meeting: Thursday, March 28, Hilton Orange County/Costa Mesa, 3050 Bristol Street, Costa Mesa, CA

Brown Act Reminder: The League of California Cities’ Board of Directors has a policy of complying with the spirit of open meeting laws. Generally, off-agenda items may be taken up only if:

- 1) Two-thirds of the policy committee members find a need for immediate action exists and the need to take action came to the attention of the policy committee after the agenda was prepared (Note: If fewer than two-thirds of policy committee members are present, taking up an off-agenda item requires a unanimous vote); or*
- 2) A majority of the policy committee finds an emergency (for example: work stoppage or disaster) exists.*

A majority of a city council may not, consistent with the Brown Act, discuss specific substantive issues among themselves at League meetings. Any such discussion is subject to the Brown Act and must occur in a meeting that complies with its requirements.

NOTE: Policy committee members should be aware that lunch is usually served at these meetings. The state’s Fair Political Practices Commission takes the position that the value of the lunch should be reported on city officials’ statement of economic interests form. Because of the service you provide at these meetings, the League takes the position that the value of the lunch should be reported as income (in return for your service to the committee) as opposed to a gift (note that this is not income for state or federal income tax purposes – just Political Reform Act reporting purposes). The League has been persistent, but unsuccessful, in attempting to change the FPPC’s mind about this interpretation. As such, we feel we need to let you know about the issue so you can determine your course of action.

If you would prefer not to have to report the value of the lunches as income, we will let you know the amount so you may reimburse the League. The lunches tend to run in the \$30 to \$45 range. To review a copy of the FPPC’s most recent letter on this issue, please go to www.cacities.org/FPPCletter on the League’s Website.

**ENVIRONMENTAL QUALITY POLICY COMMITTEE
HIGHLIGHTS**

Thursday, January 17, 2019

Sacramento Convention Center, 1400 J Street, Room 203, Sacramento CA 95814

ATTENDANCE

Members: Mireya Turner (Chair), Allan “Doc” Bernstein (V.Chair), Emily Beach, Kristi Becker, Anna Brown, Thomas Butt, Catherine Carlton, Jennifer Cavanaugh, Teresa Chen, Robert Collacott, Jim Diaz, Amanda Folendorf, Debra Garnes, Daryl Grigsby, Clay Holstine, Dan Kalb, Mina Layba, Rey Leon, Jesse Loren, Diana Mahmud, Lawrence Mainez, Julio Martinez, Marjorie Mohler, Cynthia Moran, Richard O’Brien, Oley Olsen, Kimberly Petersen, Nick Pilch, David Pollock, Randall Putz, Jason Pyle, Gabe Quinto, Joel Rojas, Robert Schultz, Mario Sierra, George Spurr, Tom Stallard, Matthew Summers, Russ Utz, Gillian van Muyden, Arwen Wacht, Kerri Warren, Kevin Wilk, James Wood

League Partners: Tim James

Staff: Erin Evans-Fudem

I. State Budget and General Briefing

The January 2019 Policy Committee meetings began with a General Session briefing. Stacey Mattina, League Housing, Community and Economic Development policy committee chair, welcomed the attendees. She then introduced League President Jan Arbuckle, Council Member, Grass Valley, who thanked them for their efforts and summarized recent meetings by League officers in the Capitol. Carolyn Coleman, League Executive Director also provided brief remarks. The rest of the briefing was then given by the League’s legislative team.

Deputy Executive Director/Legislative Director, Dan Carrigg, gave a brief overview that highlighted the importance of the League’s 2019 Strategic Goals and discussed both the state budget and legislative issues. Mr. Carrigg then introduced Michael Coleman, the League’s Fiscal Policy Advisor, to discuss the Governor’s January budget.

Mr. Coleman gave a short PowerPoint presentation on the 2019-20 January Governor’s budget. Governor Newsom’s proposed state budget includes \$144 billion in General Fund spending and when combined with proposed special fund and bond proceed allocations, totals \$209 billion. Mr. Carrigg explained that while general fund expending has increased, Governor Newsom was being fiscally prudent. The budget proposal increased the Rainy Day Reserve to \$15.3 billion, paying down a total of \$4.1 billion state pension liabilities, allocating an additional \$700 million to a social safety net reserves and \$2.3 billion in general reserves. Mr. Coleman warned that former Governor Brown warned of a looming recession and that the state needs to be prepared for a downturn. Also discussed was the makeup of the current state Legislature, including the fact that the Democrats now have a “super-duper” majority in both legislative houses. For more information about the impacts of the budget on cities, please review the [League’s analysis](#), and information on Mr. Coleman’s website [here](#). Mr. Coleman then gave Dan Carrigg the floor.

Mr. Carrigg elaborated on some of the line items included in Governor Newsom proposed budget. This included homelessness funding, mental health, and disaster recovery. Mr. Carrigg also explained the new ballot initiative process where ballot measure sponsors can now pull measures from the ballot in exchange for legislative deals. Then Mr. Carrigg introduced the League’s lobbyists to discuss their respective issue areas.

Jason Rhine, League Assistant Legislative Director, focused on the housing affordability and availability challenges throughout the state. Mr. Rhine noted that housing legislation is a high priority for the Governor, Legislature, and the League this year. He noted that if achieved, Governor Newsom's goal of producing 3.5 million housing units by 2025 would create an unprecedented level of housing production in the state. Additionally, Mr. Rhine encouraged members to be active in advocating for legislation that will help local governments address their housing challenges while preserving appropriate local control functions.

Dane Hutchings, League Legislative Representative, briefed members on issues related to governance, transparency, and labor relations. He briefly discussed sexual harassment prevention legislation that would provide rebuttable presumptions and joint-several liability with contractors. Mr. Hutchings also mentioned divestment measures, the Governor's plan to extend paid family leave, and the pending outcome of the "Cal-Fire" case. He stressed that cities are struggling with increasing costs, and securing additional flexibility for cities is a priority.

Charles Harvey, League Legislative Representative, gave an update on various public safety related issues including cannabis and cannabis deliveries, drones, police use of force, and gun legislation. On the topic of cannabis, Mr. Harvey noted that the recently authorized Bureau of Cannabis Control regulations authorizing cannabis deliveries in any jurisdiction in the state would be harmful to cities and will take effect in the spring. In addition, Mr. Harvey discussed the topic of police use of force and the likely re-introduction of a police use of force bill from last year, which was authored by Assemblymember Weber.

Erin Evans-Fudem, League Legislative Representative, highlighted evolving environmental and community issues that will be big in 2019. Ms. Evans-Fudem discussed the programs and proposed funding allocations in the cap-and-trade program. She explained how those programs would continue to be a priority for cities. In addition, Ms. Evans-Fudem discussed the importance for cities to engage in discussions about organic waste recycling regulations, disaster relief and wildfire response legislation, the ramifications of the PG&E declared forthcoming bankruptcy, and clean drinking water legislation.

Rony Berdugo, League Legislative Representative, discussed transportation, communications, and public works. Chief among them was the concept Governor Newsom proposed to tie transportation dollars from Senate Bill 1 (Beall, 2017) to housing production. Mr. Berdugo also summarized the recent Federal Communication Commission's ruling that preempts cities' ability to site telecommunications infrastructure. This proposal is similar to SB 649 (Hueso, 2017) that was vetoed by Governor Brown in 2017 and garnered over 320 opposition letters from cities.

Lastly, Dan Carrigg briefly talked about issues related to revenue and taxation. Mr. Carrigg informed the general session about the Wayfair court case and bills that could affect city sales tax. Mr. Carrigg then adjourned the general session and policy committees commenced.

Friday Special Presentation and Discussion with Governor's Representatives:

Ms. Matosantos and Mr. Elliott spoke to the general session about Governor Newsom's budgetary and legislative priorities this year. Some of these items included, housing, transportation, and healthcare. Ms. Matosanto stressed that the administration wants to work with the League and local governments on a variety of issues. Mr. Elliot talked about his decade of city service in San Francisco and how he wants to work with local governments to implement Governor Newsom's agenda. Then Ms. Matosantos and Mr. Elliott took questions from the general membership. The questions from the general session ranged, but included disaster and

emergency response, implementation of the Wayfair decision, addressing homelessness, and tying transportation dollars to housing production. It was encouraging to hear Ms. Monasatnos say that cities should not be blamed or punished for things they do not control when it comes to the production of housing. After they took numerous questions, the general session was adjourned and policy committees commenced.

II. Welcome and Introductions

Chair Turner began introductions of herself, followed by Vice-Chair Bernstein, and League Staff. This was followed by introductions from each committee member, where each member stated their name, city, title, and their top environmental quality priority for 2019.

III. Public Comment

No Public Comment.

IV. Overview of Parliamentary Procedure and Roberts Rules

This was an informational item presented by the Chair as an agenda attachment. Staff highlighted some of the key provisions and procedures the committee will follow.

V. Committee Orientation

This was an informational item presented by the Chair as an agenda attachment. Staff highlighted some of the items such as the role of staff and the importance of Committee member involvement.

VI. League Strategic Goals for 2019

The Committee reviewed the League's 2019 Strategic Goals. The goals are as follows:

1. Provide Cities Additional Funding and Tools and Preserve Local Authority to Address Housing Production, Affordability and Homelessness Challenges;
2. Improve Disaster Preparedness, Recovery and Climate Resiliency;
3. Promote Sustainability of Public Pension and Retirement Health Benefits; and
4. Address Public Safety Concerns of California Cities.

VII. Review of Existing Policy & Guiding Principles

League staff briefed committee members on the League's publication of Summary of Existing Policy and Guiding Principles, specifically the sections relating to Environmental Quality. League staff then went on to explain the process of updating the policy including the timeline, methods, history, and how the policy shapes the decisions lobbyists make in regard to legislative positions.

VIII. 2019 Draft Work Program

Following the comments made during introductions regarding members' top environmental quality priorities, the committee deliberated the 2019 work plan which will set the course for committee actions and League staff work. After a thoughtful discussion about the committee's priorities, the work program was unanimously approved after a few changes. The 2019 Environmental Quality policy committee's priorities are as follows:

1. Storm water and water quality;
2. Solid waste and recycling markets;
3. Disaster prevention, preparedness, and resiliency; and
4. CEQA.

League staff mentioned that the language and scope of each of the four priorities has been intentionally left broad to accommodate the flux of policy as the League heads into a new legislative cycle.

IX. California Department of Conservation

David Bunn, Director, and Sarah Rubin, Outreach and Engagement Coordinator at the Department of Conservation presented to the committee a demonstration of the Department's mapping technology, which serves as a valuable tool available to cities for disaster preparation, planning, and response. The maps feature active data regarding the presence of potential hazards such as landslides, earthquake-prone areas, tsunami inundation zones, and identification of areas with certain minerals, wells, mines, and toxic substances. All of these maps have the potential to be overlaid to display desired data sets with specific areas. A link to the data mapping technology can be found [here](#).

X. Institute for Local Government

Karalee Brown, Manager, and Christal Love Lazard, Manager, from the Institute for Local Government (ILG) presented to the committee an overview of the Institute's Beacon Program, which serves as a framework for local governments to share best practices in order to accomplish their goals in improving sustainability. By participating in the Beacon Program, local governments that make important strides in reducing things like greenhouse gas emissions, saving energy, and adopting policies and programs that promote sustainability can win awards, be connected to a network of similarly-motivated communities, and can even receive grant money for certain projects. ILG staff highlighted the presence of newly available funds from the passage of SB 856 of 2018, \$1 million of which will be provided to disadvantaged communities seeking to address climate change issues. For any questions regarding ILG's Beacon Program, cities can contact [Karalee Brown](#) or [Christal Love Lazard](#).

XI. Legislative Update

Erin Evans-Fudem briefed committee members on introduced legislation as well as what to expect in the coming year, including a brief description on how the legislative process operates. Ms. Evans-Fudem highlighted a few recently introduced bills related to environmental quality issues. Of note were bills related to issues like zero-emissions vehicles, recycling, and a proposal to establish a statewide central electricity procurement entity (AB 56, E. Garcia).

In addition to the staff legislative update, Tim James, League Partner and Committee Member with the California Grocers Association, gave an update regarding the regulation of food packaging. Mr. James mentioned that over 120 cities throughout the state have established local ordinances to reduce single-use plastics, particularly plastic shopping bags prior to the passage of Proposition 67 (2016) which instated a state-wide plastic bag ban.

Next Meeting: March 28, Hilton Orange County/Costa Mesa, 3050 Bristol Street, Costa Mesa

ENVIRONMENTAL QUALITY POLICY COMMITTEE

Thursday, March 28, 2019

10:00 a.m. – 3:00 p.m.

Hilton Orange County/Costa Mesa, Pacific Ballroom 1, 3050 Bristol Street, Costa Mesa

A G E N D A

SPECIAL ORDER: State Budget and Issues Briefing for all policy committee members

10:00 – 10:45 a.m., Catalina II Room

Upon adjournment, individual policy committee meetings will begin

I. Welcome and Introductions

II. Public Comment

III. Legislative Agenda (Attachment A)

Action

1. SB 54 (Allen)/AB 1080 (Gonzalez Fletcher) California Circular Economy and Plastic Pollution Reduction Act

IV. California Refuse and Recycling Council Presentation

Informational

Speakers: Kathryn Lynch, Regulatory Affairs and John Kelly Astor, Legislative Affairs for California Refuse Recycling Council, Southern District

Hear a presentation from the [California Refuse Recycling Council](#) (CRRC) on SB 1383 regulation implementation and the state recycling markets from an industry perspective. CRRC is an association representing the solid waste and recycling industry.

V. Legislative Update (Attachment B)

Informational

Speaker: Derek Dolfie, Legislative Representative

League staff will update the committee on recently introduced bills pertaining to environmental quality.

Next Meeting: Thursday, June 13, Sacramento Convention Center, Sacramento

Brown Act Reminder: The League of California Cities' Board of Directors has a policy of complying with the spirit of open meeting laws. Generally, off-agenda items may be taken up only if:

- 1) Two-thirds of the policy committee members find a need for immediate action exists and the need to take action came to the attention of the policy committee after the agenda was prepared (Note: If fewer than two-thirds of policy committee members are present, taking up an off-agenda item requires a unanimous vote); or*
- 2) A majority of the policy committee finds an emergency (for example: work stoppage or disaster) exists.*

A majority of a city council may not, consistent with the Brown Act, discuss specific substantive issues among themselves at League meetings. Any such discussion is subject to the Brown Act and must occur in a meeting that complies with its requirements.

NOTE: Policy committee members should be aware that lunch is usually served at these meetings. The state's Fair Political Practices Commission takes the position that the value of the lunch should be reported on city officials' statement of economic interests form. Because of the service you provide at these meetings, the League takes the position that the value of the lunch should be reported as income (in return for your service to the committee) as opposed to a gift (note that this is not income for state or federal income tax purposes – just Political Reform Act reporting purposes). The League has been persistent, but unsuccessful, in attempting to change the FPPC's mind about this interpretation. As such, we feel we need to let you know about the issue so you can determine your course of action.

If you would prefer not to have to report the value of the lunches as income, we will let you know the amount so you may reimburse the League. The lunches tend to run in the \$30 to \$45 range. To review a copy of the FPPC's most recent letter on this issue, please go to www.cacities.org/FPPCletter on the League's Website.

ENVIRONMENTAL QUALITY POLICY COMMITTEE HIGHLIGHTS

Thursday, March 28, 2019

Hilton Orange County/Costa Mesa, Pacific Ballroom 1, 3050 Bristol Street, Costa Mesa

ATTENDANCE

Members: Mireya Turner (Chair), Allan “Doc” Bernstein (V.Chair), Emily Beach, Kristi Becker, Thomas Butt, Jon Canavan, Catherine Carlton, Jennifer Cavanaugh, Teresa Chen, Margaret Clark, Robert Collacott, Kaila DeFries, Denise Diaz, Jim Diaz, Pat Eklund, Dan Kalb, Mina Layba, Jesse Loren, Lawrence Mainez, Julio Martinez, Marjorie Mohler, Vong Mouanoutoua, Oley Olsen, June Overholt, David Pollock, Randall Putz, Jason Pyle, Gabe Quinto, Lisa Ann Rapp, Chris Rogers, Robert Schultz, Mario Sierra, George Spurr, Tom Stallard, Matthew Summers, Russ Utz, Gillian van Muyden, Fabian Villenas, Arwen Wacht, Kerri Warren, Kevin Wilk, James Wood

League Partners: Tim James

Staff: Derek Dolfie

I. State Budget and General Briefing

Stacey Mattina, Chair, League Housing, Community and Economic Development Policy Committee, gave a brief introduction to the General Briefing Session. After her welcome, she introduced League President Jan Arbuckle, Council Member, Grass Valley, who welcomed everyone to the second round of policy committee meetings of the year. President Arbuckle then introduced Rich Garbarino, League Immediate Past President, Carolyn Coleman, League Executive Director, and acknowledged all of the League Partners in the room.

President Arbuckle then shared a highlight of the most recent League board meeting where the Board had the pleasure of meeting with newly elected Governor Gavin Newsom. Arbuckle stated that the Governor’s decision to visit the League Board of Directors and his willingness to stay for over an hour demonstrates the importance of our collective city voice. She encouraged everyone in the room to register for the League’s Legislative Action Day and remain engaged, then handed the meeting over to Carolyn Coleman.

Ms. Coleman thanked President Arbuckle for all of the hard work she dedicates to her role, and then emphasized the importance of the policy committees in developing the Leagues positions on key issues. She then introduced Dan Carrigg, League Deputy Executive Director and Legislative Director. The rest of the briefing was presented by the League’s legislative team.

Mr. Carrigg began by reinforcing the importance of showing up for Legislative Action Day and meeting with Assembly Members and Senators face to face. Mr. Carrigg then introduced the League’s fiscal advisor, Michael Coleman, to walk everyone through the State Budget update. Mr. Coleman briefly discussed the moderate growth of the economy, but acknowledged that there are some signs of a slowing economy, and stressed the importance of maintaining a balanced budget.

Mr. Carrigg then gave an overview of the political dynamics of having a new Governor, a Democratic legislative super majority, and longer legislative term limits. He said that legislators and interest groups are inclined to test Governor Newsom by sending him many bills Governor Brown would not previously sign. This would be a year when we will all find out what the Governor is willing to say no to.

Mr. Carrigg went on to discuss two important economic development bills, SB 5 and AB 11. Both of these measures would reinvest the state into tax increment financing. A renewed investment would greatly improve opportunities for economic development and provide a great opportunity for the state to work with locals to accomplish shared state and local goals. Mr. Carrigg then referred to [a hand out with a list of the current economic development tools](#) currently available to cities. In addition, Mr. Carrigg discussed ACA 1 and several initiatives that have qualified for the ballot including the split roll, bail reform, and the Grocers and Police Chiefs criminal justice reform initiative. Then Mr. Carrigg introduced the League's lobbyists to discuss their respective issue areas.

Jason Rhine, League Assistant Legislative Director, focused on the housing affordability and availability challenges throughout the state. Mr. Rhine noted that housing legislation is a high priority for the Governor, Legislature, and the League this year. He noted that if achieved, Governor Newsom's goal of producing 3.5 million housing units by 2025 would create an unprecedented level of housing production in the state. Additionally, Mr. Rhine encouraged members to engage and advocate for legislation that will help local governments address their housing challenges while preserving appropriate local control.

Mr. Rhine also briefly discussed the Governor's housing trailer bill proposal and [a short list of bills of significant concern](#). This year, he said, housing related legislation touches on nearly every section of housing law before many of the laws enacted over the past two years have had time to be implemented. The League has been working closely with the Governor's office and Legislators on the trailer bill language and the 200+ housing related bills introduced this legislative session.

Dane Hutchings, League Legislative Representative, briefed members on issues related to governance, transparency, and labor relations. Mr. Hutchings began by discussing the political realities in Sacramento surrounding employee relations legislation and then briefly discussed several bills regarding worker compensation and elections. Mr. Hutchings also highlighted AB 1332, which would significantly limit the ability for state and local agencies to cost-effectively contract for a variety of public services, create an ever-evolving blacklist of prohibited companies and create millions of dollars of unfunded mandates. Mr. Hutchings also briefly discussed the recent [Cal Fire pension decision](#) and its impact.

Charles Harvey, League Legislative Representative, gave an update on various public safety related issues including cannabis and cannabis deliveries, drones, police use of force, and gun legislation. On the topic of cannabis, Mr. Harvey discussed the legislative and expected judicial challenges of the recent Bureau of Cannabis Control regulations authorizing cannabis deliveries in any jurisdiction in the state. In addition, Mr. Harvey discussed AB 392 (Weber), the re-introduction of a police use-of-force bill from last year, which the League opposed, and SB 230 (Caballero) an alternative bill backed by police chiefs that the League would likely support.

Derek Dolfie, League Legislative Representative, highlighted evolving environmental and community issues that will be big in 2019. A major issue is organic waste diversion and the regulations that will implement a 50% reduction target coming out this summer. Mr. Dolfie also discussed various proposals that seek to provide clean water to California residents. He also touched on bills regarding recycling, energy, disaster preparedness, storm water, aging, homelessness and tobacco use regulations.

Rony Berdugo, League Legislative Representative, discussed transportation, communications, and public works. Mr. Berdugo began by discussing the proposal to link SB 1 transportation

dollars with housing production. The proposal was met with hostility by many legislators and Mr. Berdugo suggested that folks in the room speak to their legislator and tell them that this proposal should not move forward. Next, he discussed the FCC small cell order and how the League and others have attempted to push back against this in the courts and on the federal level. Finally, Mr. Berdugo discussed emergency alert legislation and disaster preparedness regarding seismic safety.

Lastly, Dan Carrigg briefly discussed issues related to revenue and taxation. Mr. Carrigg touched on the League's support of AB 147 (Burke) which would implement the *Wayfair* decision in California and increase revenue for local governments, and discussed legislation that would limit sales tax agreements that shift revenue from other jurisdictions.

II. Welcome and Introductions

Chair Mireya Turner and Vice Chair Allan "Doc" Bernstein, welcomed the committee members and asked them to briefly introduce themselves.

III. Public Comment

No public comment.

IV. Legislative Agenda

League Legislative Representative Derek Dolfie presented the legislative agenda to the committee.

[SB 54 \(Allen\)](#) & [AB 1080 \(Gonzalez\)](#) California Circular Economy and Plastic Pollution Reduction Act.

Derek Dolfie summarized SB 54/AB 1080, these identical bills would require the Department of Resources Recycling and Recovery (CalRecycle), in consultation with the State Water Resources Control Board (SWRCB) and the Ocean Protection Council (OPC), to adopt regulations to source reduce and recycle at least 75% of single-use packaging and products sold or distributed in California by 2030, require that all single-use plastics sold or distributed in California be recyclable or compostable by 2030, and require CalRecycle to develop a scoping plan to achieve those requirements.

The committee discussed several aspects of the bill including some technical and implementation related questions. The committee made several motions. The first motion was to approve the staff recommendation to support the bill, but direct staff to address several questions. Then a substitute motion was made to take no action on the bill. After taking numerous questions, the motion to take no action failed, and the motion to support the bill addressing certain questions passed.

Committee Recommendation:

Approve the staff recommendation to take a support position and direct staff to address various details on SB 54 (Allen) and AB 1080 (Gonzalez).

The details and questions included:

- If the bill could make a larger commitment to recycling infrastructure;
- Why the author is using 2030 as the date to implement the bill;
- Why the author decided to make single use plastics compostable and recyclable and not only compostable,
- Who makes the determination on what is considered a "single use plastic"; and
- How CalRecycle will implement the program.

- Additionally, the committee would like to see if an amendment could be made in section 42045(d)(1), by changing the “may” into a “shall” in the sentence, “In implementing this section, the department **may** consult with local governments and representatives of the solid waste industry, the recycling industry, the compost industry, and single-use packaging or product is recyclable, reusable, or compostable” (emphasis added).

Committee Action: Approved on a 25-9 vote.

V. California Refuse and Recycling Council Presentation

Chair Turner welcomed Kathryn Lynch and John “Kelly” Astor from the [California Refuse Recycling Council, Southern District](#) (CRRC) to the committee. Ms. Lynch and Mr. Astor gave a brief overview of CRRC and explained that their association represents waste haulers in Southern California and has worked in collaboration with the League and local governments on solid waste issues in the past.

Ms. Lynch and Mr. Astor then gave a brief presentation on some of the challenges that waste haulers are facing on various issues, including the implementation of the new [SB 1383](#) (Lara, 2016) administered by the [California Department of Resources Recycling and Recovery](#) (CalRecycle). They explained that the mandates in the regulations put forth by CalRecycle are nearly impossible to comply with and will cost local governments and haulers millions if not billions to comply. They stressed that this could cause costs to go up for their customers and our constituents.

Additionally, Ms. Lynch and Mr. Astor also discussed with the committee the collapse of recycling markets in California. For years, California sold the majority of its recyclable materials to China. But, over the last several years, China has implemented severe restrictions on what recyclable materials they will accept and have announced that they will no longer take any recyclable materials by 2020. With this change in global recycling markets, local governments and haulers have less and less buyers for their recyclable materials. Ms. Lynch and Mr. Astor stressed that this problem is another looming problem local governments and haulers must face.

Lastly, Ms. Lynch and Mr. Astor also discussed the partnerships that they would like to strengthen with local governments to push back on these regulations and other legislative proposals that seek to infringe on local control in the solid waste industry.

After their presentation, Ms. Lynch and Mr. Astor took numerous questions from the committee. Some of the committee members expressed their frustration with the presentation given by CRRC, and asked what solutions could be developed for the issues discussed. Ms. Lynch and Mr. Astor reiterated that they share the frustration of local governments on this issue and wanted to work with them on developing solutions, but did not have immediate answers. Committee members also asked the speakers about CRRC’s commitment to moving to more environmentally sustainable products and reducing the amount of waste in the waste stream. Ms. Lynch and Mr. Astor are supportive of developing more environmentally friendly products and are at the table to work on those solutions as they are being developed.

VI. Legislative Update

Mr. Dolfie gave a legislative update to the committee on several bills related to environmental quality. The main categories of bills discussed were solid waste, safe and affordable drinking water fund, disaster prevention, preparedness and resiliency, and energy, utilities, and water.

2019 Work Plan Items Covered to Date:

- [Storm water and water quality:](#)

- Governor’s Trailer Bill on Water Tax – Update/Presentation
- SB 669 (Caballero) Water Quality: Safe Drinking Water Fund – Update/Presentation
- SB 200 (Monning) Safe and Affordable Drinking Water Fund – Update/Presentation
- AB 217 (E. Garcia) Safe Drinking Water for All Act – Update/Presentation
- AB 134 (Bloom) Safe, clean, affordable, and accessible drinking water – Update/Presentation
- AB 755 (Holden) California tire fee: Stormwater Permit Compliance Fund – Update/Presentation
- SB 205 (Hertzberg) Business licenses: stormwater discharge compliance – Update/Presentation
- SB 332 (Hertzberg) Waste Water Treatment: Recycled Water – Update/Presentation
- Solid waste and recycling markets:
 - AB 1171 (Chen) Recycling: grocery store food packaging: sustainability standards – Update/Presentation
 - SB 33 (Skinner) Solid waste: reduction and recycling – Update/Presentation
 - SB 54 (Allen) / AB 1080 (Gonzalez) California Circular Economy and Plastic Pollution Reduction Act – Action Item
 - SB 667 (Hueso) Greenhouse gases: recycling infrastructure and facilities – Update/Presentation
 - SB 515 (Caballero) California Renewables Portfolio Standard Program: bioenergy renewable feed-in tariff – Update/Presentation
 - SB 1383 (Lara, 2016) Implementation, CalRecycle – Update/Presentation
- Disaster prevention, preparedness, and resiliency:
 - SB 45 (Allen) Wildfire, Drought, and Flood Protection Bond Act of 2020 – Update/Presentation
 - SB 209 (Dodd) Wildfire: California Wildfire Warning Center: weather monitoring – Update/Presentation

VII. Additional Comments

After the committee’s lengthy discussion on reducing waste, single-use plastics, and recycling markets, several committee members expressed their desire to reduce the amount of waste the League’s policy committee lunches’ generate. Those members requested that League staff look into if and how the policy committee lunch waste could be reduced for future meetings.

League legislative staff has informed the League’s Education & Member Services department, who handle meeting and conference planning, of the committee’s request. League staff will continue to look into this issue to assess the best possible way to reduce policy committee lunch waste in the future.

Next Meeting: Thursday, June 13, Sacramento Convention Center, Sacramento

Staff Report

TO: Mayor and City Council Members
FROM: Nicole Wheelwright, Deputy City Clerk
DATE: May 21, 2019
SUBJECT: Reimbursement of Travel Expenses to Council Member Lloyd White

Background and Analysis:

Per the adopted Travel Expense and Reimbursement Policy, a Travel Expense Report Form has been completed by Council Member Lloyd White for his travel expense incurred in attendance of a League of California Cities conference and meeting. The expenses listed follow the guidelines of the policy of reimbursable items as well as the allotment of per diem, using the IRS rates.

Fiscal Impact:

The total of the reimbursement request is \$45.24 to be paid out of Council's Travel Expense budget in account 100-1050-7035-0000.

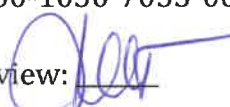
Finance Director Review: 

Recommendation:

Approve the reimbursement request in the amount of \$45.24.

City Manager Review: 

Attachments:

A. Travel and Training Reimbursement Form

CITY OF BEAUMONT RESIDENT TRAVEL AUTHORIZATION AND EXPENSE REPORT FORM

THIS IS A (check one): REQUEST FOR TRAVEL ADVANCE or PER DIEM CLAIM FOR REIMBURSEMENT

NAME LLOYD WHITE **DEPARTMENT** CITY COUNCIL **DATE OF ADVANCE REQUEST / CLAIM** 5-6-19

POSITION CITY COUNCIL **PURPOSE OF TRIP** ERICA MEETING **AUTHORIZED BY:** **DATE:**

METHOD OF TRANSPORTATION **DEPARTED FROM** **ARRIVED AT**

NAME (Delta, Amtrak, etc.)	NAME OF CITY	DATE	TIME	NAME OF CITY	DATE	TIME
PERS. VEHICLE	BEAUMONT	4/24/19		CATHEDRAL CITY	4/24/19	
II	CATHEDRAL CITY	4/24/19		BEAUMONT	4/24/19	

DESCRIPTION	DATES						TOTAL
	Pre-Trip	4/24					
BREAKFAST							
LUNCH							
DINNER							
PER DIEM (M & IE)							
LODGING							
MAJOR TRANSPORTATION							
CAR RENTAL							
MILEAGE 39 mi 1 way		45.24				45.24	
PARKING							
TAXI, SHUTTLE, ETC.							
TELEPHONE							
REGISTRATION FEE							
MISC. (explain below)							
TOTAL						45.24	

EXPLANATION OF ITEMS:

The undersigned, under penalty of perjury, states that the above claim is correct:

REQUEST FOR ADVANCE or PER DIEM **AMOUNT**

Lloyd White 5/7/19
Employee/Elected Signature Date

ACTUAL EXPENDITURES
CASH ADVANCE OR PER DIEM RECEIVED
PAID IN ADVANCE OF EVENT (other than credit card)
PAID VIA PERSONAL CREDIT CARD

[Signature] 5/14/19
Approved by Dept Head Date

LAST 4 DIGITS OF CARD #: _____
Highlight all expenses paid by credit card

Approved by City Manager Date
(required for out-of-state travel only)

TOTAL DUE TO CITY TO TRAVELER

Finance Review Travel Coordinator

DEPT. NO. - EXPENDITURE NO. Amount per account

Commonly Used Account
XXXX DEPT NUMBER
4035 TRAVEL, TRAINING & MEETINGS

(.56)