



## **CITY COUNCIL CLOSED & REGULAR SESSION**

550 E. 6th Street, Beaumont, Ca

**Tuesday, January 07, 2020**

**Closed Session: 5:00 PM | Regular Meeting: 6:00 PM**

### **AGENDA**

---

Materials related to an item on this agenda submitted to the City Council after distribution of the agenda packets are available for public inspection in the City Clerk's office at 550 E. 6th Street during normal business hours

Any person with a disability who requires accommodations in order to participate in this meeting should telephone the City Clerk's office at (951)769-8520, at least 48 hours prior to the meeting in order to make a request for a disability related modification or accommodation

Any one person may address the City Council on any matter not on this agenda. If you wish to speak, please fill out a "Public Comment Form" provided at the back table and give it to the City Clerk. There is a three (3) minute limit on public comments. There will be no sharing or passing of time to another person. State law prohibits the City Council from discussing or taking actions brought up by your comments.

---

#### **CLOSED SESSION - 5:00 PM**

*A Closed Session of the City Council / Beaumont Financing Authority / Beaumont Utility Authority / Beaumont Successor Agency (formerly RDA)/Beaumont Parking Authority / Beaumont Public Improvement Authority may be held in accordance with state law which may include, but is not limited to, the following types of items: personnel matters, labor negotiations, security matters, providing instructions to real property negotiators and conference with legal counsel regarding pending litigation. Any public comment on Closed Session items will be taken prior to the Closed Session. Any required announcements or discussion of Closed Session items or actions following the Closed Session will be made in the City Council Chambers.*

#### **CALL TO ORDER**

**Mayor Santos, Mayor Pro Tem Lara, Council Member Carroll, Council Member Martinez, Council Member White**

Public Comments Regarding Closed Session

- 1. Conference with Labor Negotiators - Pursuant to Government Code Section 54957.6 City Designated Representatives City Manager Todd Parton and Administrative Services Director Kari Mendoza. Employee Organizations: Police Management Managers/Professional/Technical as Individuals**

Adjourn to Regular Session

**REGULAR SESSION - 6:00 PM**

**2. Council Reorganization**

**CALL TO ORDER**

**Mayor Santos, Mayor Pro Tem Lara, Council Member Carroll, Council Member Martinez, Council Member White**

- Report out from Closed Session:
- Action on any Closed Session items:
- Action of any requests for Excused Absence:
- Pledge of Allegiance:
- Approval / Adjustments to the Agenda:
- Conflict of Interest Disclosure:

**ANNOUNCEMENTS/ RECOGNITION / PROCLAMATIONS / CORRESPONDENCE**

**1. Point in Time Homeless Count Presentation**

**PUBLIC COMMENT PERIOD (ITEMS NOT ON THE AGENDA)**

*Any one person may address the City Council on any matter not on this agenda. If you wish to speak, please fill out a "Public Comment Form" provided at the back table and give it to the City Clerk. There is a three (3) minute time limit on public comments. There will be no sharing or passing of time to another person. State Law prohibits the City Council from discussing or taking actions brought up by your comments.*

**CONSENT CALENDAR**

*Items on the consent calendar are taken as one action item unless an item is pulled for further discussion here or at the end of action items.*

*Approval of all Ordinances and Resolutions to be read by title only.*

**2. Ratification of Warrants**

- Warrants dated 11.21.19
- Warrants dated 12.26.19
- Warrants dated 12.05.19
- Warrants dated 12.12.19

**3. Approval of Minutes**

- Minutes of 11.21.19 Workshop
- Minutes of 12.03.19
- Minutes of 12.19.17 Special Meeting and Workshop

**4. Adopt an Amendment to Table 17.03-3 Permitted Uses in Base Zone District and Table 17.03-4 Permitted Uses in Overlay Zone Districts, Large Family Daycare**

Recommended Action:

Waive the second full reading and approve by title only, "An Ordinance of the City of Beaumont Approving an Amendment and Addition to the City of Beaumont Municipal Code Pertaining to the Regulation of Large Family



Daycares: Amending Table 17.03-3 'Permitted Uses for Base Zone Districts' and Table 17.03-4 Permitted Uses in Overlay Zone Districts."

**5. Council Direction to Prepare a Report Pursuant to California Health and Safety Code Sections 13145 and 13146 to be Accepted by the Council**

Recommended Action:

Direct staff to prepare the report for acceptance by the City Council at its January 21, 2020, regular meeting.

**6. Request for Destruction of Retention Met Records**

Recommended Action:

Waive the full reading and adopt by title only, "A Resolution of the City of Beaumont Authorizing Destruction of Certain Records in Accordance with the Records Retention Schedule Adopted by City Council."

**7. Declaration of Surplus Property and Request for Disposal**

Recommended Action:

Approve disposal of identified City surplus property.

**8. Quarterly Status of City Council Travel and Training Reimbursements**

Recommended Action:

Receive and file.

**PUBLIC HEARINGS**

*Approval of all Ordinances and Resolutions to be read by title only.*

**ACTION ITEMS**

*Approval of all Ordinances and Resolutions to be read by title only.*

**9. Approve Implementation of National Community Survey Via Hard Copy Surveys with the Following Add-on Options: Larger Sample Size, Reminder Postcard, Spanish Translation, Custom Benchmark Comparisons, Open-Ended Question, and an In-Person Presentation**

Recommended Action:

Approve implementation of National Community Survey via hard copy surveys with the following add-on options: larger sample size, reminder postcard, Spanish translation, custom benchmark comparisons, open-ended question, and an in-person presentation with a budget not to exceed \$30,000.

**10. Updates of the Annual Slurry Seal Project (CIP2019-001), Alleyway Rehabilitation Project (CIP2018-003), Beaumont Avenue Rehabilitation Project (CIP2018-004 & CIP2019-002), Beaumont Avenue Signalization Study (CIP2019-017), and the City Crack Sealing Operation**

Recommended Action:

Receive and file updates for the Annual Slurry Seal Project (CIP2019-001), Alleyway Rehabilitation Project (CIP2018-003), Beaumont Avenue Rehabilitation Project (CIP2018-004 & CIP2019-002), Beaumont Avenue Signalization Study (CIP2019-017), and the City Crack Sealing Operation.

**11. Approve the Purchase of One (1) F150 Super Crew Work Truck and One (1) F350 Super Crew Utility Truck in the Amount of \$74,760.75 from Fritts Ford**

Recommended Action:

Approve staff to purchase one F150 Super Crew work trucks and one F350 Super Crew utility Bed truck in the amount of \$74,760.75 from Fritts Ford.

**12. Approval of Payment for Fire Protection Services**

Recommended Action:

Approval of payment of first quarter fire protection services to the County in the amount of \$952,444.77.

**13. City Council Approval of Change Order No. 12 for the Wastewater Treatment Plant Upgrade/Expansion in the Amount Not to Exceed \$91,417.26**

Recommended Action:

Approval of Change Order No. 12 for the Wastewater Treatment Plant Upgrade/Expansion in the amount not to exceed \$91,417.26.

**14. City Council Approval of Change Order No. 13 for the Wastewater Treatment Plant Upgrade/Expansion in the Amount Not to Exceed \$404,821.33**

Recommended Action:

Approval of Change Order No. 13 for the Wastewater Treatment Plant Upgrade/Expansion in the amount not to exceed \$404,821.33.

**15. Authorize Mayor to Make Appointments to the Various Boards, Commissions and Committees**

Recommended Action:

Mayoral appointments of City Council members to various boards, commissions and committees.

**LEGISLATIVE UPDATES AND DISCUSSION**

**COUNCIL REPORTS**

- Carroll
- Lara
- Martinez
- Santos
- White

**ECONOMIC DEVELOPMENT UPDATE**

Economic Development Committee Report Out and City Council Direction

**CITY TREASURER REPORT**

Finance and Audit Committee Report Out and City Council Direction

**CITY CLERK REPORT**

**CITY ATTORNEY REPORT**

## 16. Status of Pending Litigation

### **CITY MANAGER REPORT**

### **FUTURE AGENDA ITEMS**

### **ADJOURNMENT**

The next regular meeting of the Beaumont City Council, Beaumont Financing Authority, the Beaumont Successor Agency (formerly RDA), the Beaumont Utility Authority, the Beaumont Parking Authority and the Beaumont Public Improvement Agency is scheduled for Tuesday, January 21, 2020 at 5:00 p.m. or thereafter as noted on the posted Agenda for Closed Session items in the City Council Board Room No. 5, followed by the regular meeting at 6:00 p.m. or thereafter as noted on the posted Agenda at City Hall.

Beaumont City Hall – Online [www.BeaumontCa.gov](http://www.BeaumontCa.gov)

**Item Attachment Documents:**

- 1. Point in Time Homeless Count Presentation**



# Point-in-Time 2020

*Riverside County  
Department of Public Social Services  
Fifth District Supervisor Jeff Hewitt*

# Point in Time

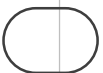

*Federally-mandated by the U.S. Department of Housing and Urban Development (HUD) to count and survey the homeless population in the United States.*

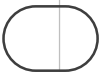

*Data collected during the count reflects a snapshot of Riverside County's homeless population at one particular point-in-time.*

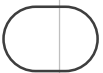

*Point in Time data play a critical role in the Continuum of Care (CoC) Program Competition and HUD will continue to emphasize through its scoring the significance of the data reported as well as the process for the data collection.*



# 2019

## County Overview

**2,811**  
**Sheltered and unsheltered homeless adults and children county-wide**

## Breakdown

*Veterans: 107 total unsheltered PIT count for 2019 (8% increase from 2018)*

*Youth (18-24)– 181 total unsheltered PIT count for 2019 (2% increase from 2018)*

*Elderly (aged 62 and over – interview only) – 129 total unsheltered PIT count for 2019 (16% increase)*

*Children (17 or under) – 15 Total unsheltered for 2019*

*Families w/Children (interview only) – 2 total unsheltered for 2019 (50% decrease from 2018)*

*Youth count total – 196 total unsheltered in count for 2019 (8% increase from 2018)*

*Chronically Homeless- 727 total unsheltered PIT count for 2019 (88% increase from 2018)*

## District 5 Overview 1.

**21% Decrease (2019 VS. 2019)**

**Total unsheltered homeless count: 211**

### Breakdown:

*Native American: 5*

*Black: 32*

*Native Hawaiian: 6*

*White: 115*

*Multiple Races: 22*

*Unknown Race:*

*27*



# Methodology

**Service-based Count (multi-day)** - A survey of people at various social service locations or other public or private locations to identify people who were unsheltered, but not counted because they were missed on the day of the count.

**Unsheltered Count** - Individuals and families “with a primary nighttime residence that is a public or private place not designed for or ordinarily used as a regular sleeping accommodation for human beings, including a car, park, abandoned building, bus or train station, airport, or camping ground” on the night designated for the count.

Street-Based Count



Service-Based Count



Point in Time Count



Follow- Up Count and Survey:



Unaccompanied Youth (Age 24-& Under)

# Homelessness Challenges

1.

Mental Health

Substance Abuse

Deep Poverty

Public Health



11



# Addressing Homelessness Together

Working collaboratively with each city will create stepping stones toward a comprehensive regional approach to addressing various homeless needs.



# How to Get Involved

1.

**Volunteer Registration Ends January 20<sup>th</sup>, 2020**

Opportunities:

General Point-In-Time Count  
Wednesday, January 29<sup>th</sup>  
5:30 AM – 9:30 AM

Youth Point-In-Time Count  
Thursday, January 29<sup>th</sup>- 31<sup>st</sup>  
2:00 PM- 8:00 PM

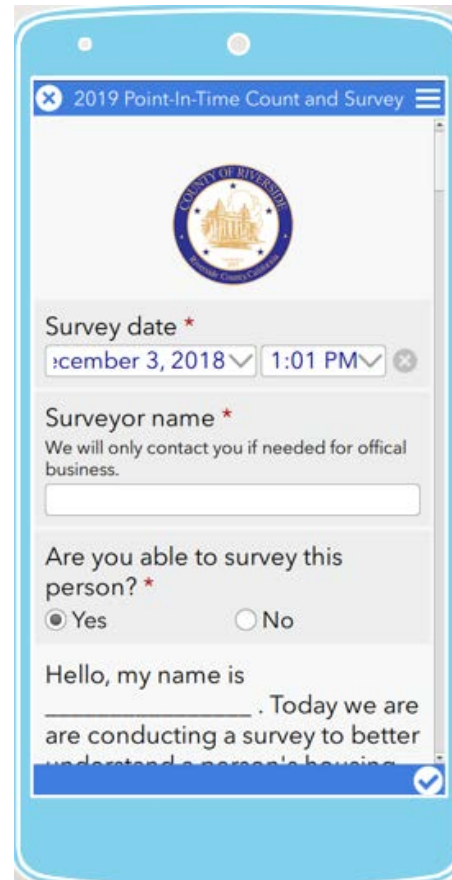

All Volunteers must have a smartphone  
To download Survey123

Consider following the link to get involved:

[www.RIVCOEXCHANGE.com](http://www.RIVCOEXCHANGE.com)

# Thank You

Questions.

**Item Attachment Documents:**

**2. Ratification of Warrants**

Warrants dated 11.21.19

Warrants dated 12.26.19

Warrants dated 12.05.19

Warrants dated 12.12.19





**WARRANTS TO BE RATIFIED**

Thursday, November 21, 2019

<b>Printed Checks</b>	103931-104035	\$	410,802.78	FY 19/20
	A/P Total	\$	<u>410,802.78</u>	

<b>Payroll</b>		\$	471,945.58	PPE 10/31/19
----------------	--	----	------------	--------------

I DO HEREBY CERTIFY THIS WARRANT LIST HAS BEEN COMPILED AND PREPARED TO MEET THE DAILY OPERATIONS FOR THE FISCAL YEAR JULY 1, 2019 - JUNE 30, 2020

SIGNATURE: *Barry Bennett*  
 TITLE: CITY TREASURER

SIGNATURE: *[Signature]*  
 TITLE: ADMINISTRATIVE SERVICES DIRECTOR





2.

Vendor Number	Vendor Name	Payment Date	Payment Type	Discount Amount	Payment Amount	Number
2988	RHONDA KEYSER	11/21/2019	Regular	0.00	1,525.84	103931
<b>Payable #</b>	<b>Payable Type</b>	<b>Post Date</b>	<b>Payable Description</b>	<b>Discount Amount</b>	<b>Payable Amount</b>	
<u>PD 11/22/19</u>	Invoice	11/20/2019	SPOUSAL SUPPORT	0.00	1,525.84	
	<u>100-0000-2057-0000</u>		OTHER WITHHOLDINGS		1,525.84	
			SPOUSAL SUPPORT			
1004	A-1 AUTO ELECTRIC	11/21/2019	Regular	0.00	407.93	103932
<b>Payable #</b>	<b>Payable Type</b>	<b>Post Date</b>	<b>Payable Description</b>	<b>Discount Amount</b>	<b>Payable Amount</b>	
<u>122837</u>	Invoice	11/20/2019	VEHICLE MAINTENANCE	0.00	407.93	
	<u>750-7700-7037-0000</u>		VEHICLE MAINTENANCE		407.93	
			VEHICLE MAINTENANCE			
1006	AB LANDSCAPE	11/21/2019	Regular	0.00	425.00	103933
<b>Payable #</b>	<b>Payable Type</b>	<b>Post Date</b>	<b>Payable Description</b>	<b>Discount Amount</b>	<b>Payable Amount</b>	
<u>2019 CHAMPION</u>	Invoice	11/20/2019	WEED ABATEMENT SERVICES	0.00	425.00	
	<u>100-2030-7039-0000</u>		CODE ENFORCEMENT		425.00	
			WEED ABATEMENT SERVICES			
1014	ACE ALTERNATORS	11/21/2019	Regular	0.00	280.58	103934
<b>Payable #</b>	<b>Payable Type</b>	<b>Post Date</b>	<b>Payable Description</b>	<b>Discount Amount</b>	<b>Payable Amount</b>	
<u>112342</u>	Invoice	11/20/2019	VEHICLE MAINTENANCE	0.00	140.29	
	<u>750-7800-7037-0000</u>		VEHICLE MAINTENANCE		140.29	
			VEHICLE MAINTENANCE			
<u>112398</u>	Invoice	11/20/2019	VEHICLE MAINTENANCE	0.00	140.29	
	<u>750-7800-7037-0000</u>		VEHICLE MAINTENANCE		140.29	
			VEHICLE MAINTENANCE			
3295	ADAM HALL	11/21/2019	Regular	0.00	2,020.31	103935
<b>Payable #</b>	<b>Payable Type</b>	<b>Post Date</b>	<b>Payable Description</b>	<b>Discount Amount</b>	<b>Payable Amount</b>	
<u>008145</u>	Invoice	11/20/2019	DEPT SUPPLIES	0.00	2,020.31	
	<u>100-6050-7070-018X</u>		SPEC DEPT EXP - IA 18		2,020.31	
			DEPT SUPPLIES			
1050	AMAZON CAPITAL SERVICES	11/21/2019	Regular	0.00	934.52	103936
<b>Payable #</b>	<b>Payable Type</b>	<b>Post Date</b>	<b>Payable Description</b>	<b>Discount Amount</b>	<b>Payable Amount</b>	
<u>14P1-V3C9-31J4</u>	Invoice	11/20/2019	DEPT SUPPLIES	0.00	361.93	
	<u>100-2050-7070-0000</u>		SPECIAL DEPT SUPPLIES		361.93	
			DEPT SUPPLIES			
<u>17F4-WTFQ-1TL9</u>	Invoice	11/20/2019	DEPT SUPPLIES	0.00	235.95	
	<u>100-2050-7070-0000</u>		SPECIAL DEPT SUPPLIES		235.95	
			DEPT SUPPLIES			
<u>1MM3-CT1V-4X3</u>	Invoice	11/20/2019	OFFICE SUPPLIES	0.00	101.48	
	<u>100-1350-7025-0000</u>		OFFICE SUPPLIES		85.49	
	<u>100-2030-7025-0000</u>		OFFICE SUPPLIES		15.99	
			OFFICE SUPPLIES			
<u>1QYN-LGQV-CCN</u>	Invoice	11/20/2019	OFFICE SUPPLIES	0.00	216.16	
	<u>100-2050-7025-0000</u>		OFFICE SUPPLIES		216.16	
			OFFICE SUPPLIES			
<u>1XKJ-PQH4-7MK</u>	Invoice	11/20/2019	DEPT SUPPLIES	0.00	19.00	
	<u>100-3100-7070-0000</u>		SPECIAL DEPT SUPPLIES		19.00	
			DEPT SUPPLIES			
3836	ANTHONY OCHOA	11/21/2019	Regular	0.00	40.00	103937

Check Report

Date Range: 11/15/2019 - 11/15/2019

2.

Vendor Number	Vendor Name	Payment Date	Payment Type	Discount Amount	Payment Amount	NU
Payable #	Payable Type	Post Date	Payable Description	Discount Amount	Payable Amount	
	Account Number	Account Name	Item Description	Distribution Amount		
<u>RCT 943897</u>	Invoice	11/20/2019	DEPOSIT REFUND	0.00	40.00	
	<u>100-0000-4590-0000</u>		BUILDING RENTAL		40.00	
1100	AUTOZONE	11/21/2019	Regular	0.00	5.24	103938
<u>2882101931</u>	Invoice	11/20/2019	VEHICLE MAINTENANCE	0.00	68.05	
	<u>750-7800-7037-0000</u>		VEHICLE MAINTENANCE		68.05	
<u>2882108328</u>	Credit Memo	11/20/2019	VEHICLE MAINTENANCE	0.00	-62.81	
	<u>750-7800-7037-0000</u>		VEHICLE MAINTENANCE		-62.81	
1005	A-Z BUS SALES, INC.	11/21/2019	Regular	0.00	213.63	103939
<u>01P688237</u>	Invoice	11/20/2019	VEHICLE MAINTENANCE	0.00	213.63	
	<u>750-7800-7037-0000</u>		VEHICLE MAINTENANCE		213.63	
3752	BAKER ELECTRIC INC	11/21/2019	Regular	0.00	7,867.61	103940
<u>34200</u>	Invoice	11/21/2019	Public Electric Vehicle Charging Station	0.00	7,867.61	
	<u>760-0000-8030-0000</u>		INFRASTRUCTURE IMPRO		7,867.61	
3837	BALWINDER SINGH	11/21/2019	Regular	0.00	51.64	103941
<u>06-011181-02</u>	Invoice	11/20/2019	REIMBURSE CREDIT ON UTILITY ACCOUNT	0.00	51.64	
	<u>100-0000-1400-0000</u>		A/R - UTILITIES		51.64	
1109	BANK OF HEMET	11/21/2019	Regular	0.00	3,726.94	103942
<u>1280837350 11/1</u>	Invoice	11/20/2019	EQUIPMENT PAYMENT	0.00	3,726.94	
	<u>100-6050-8040-0000</u>		EQUIPMENT		3,726.94	
3129	BC RENTALS, INC	11/21/2019	Regular	0.00	90.83	103943
<u>0043741-IN</u>	Invoice	11/21/2019	STREET MAINTENANCE SUPPLIES	0.00	90.83	
	<u>100-3250-7070-0000</u>		SPECIAL DEPT SUPPLIES		90.83	
1127	BEAUMONT DO IT BEST HOME CENTER	11/21/2019	Regular	0.00	559.96	103944
<u>478739</u>	Invoice	11/21/2019	DEPARTMENT SUPPLIES - SEWER	0.00	41.86	
	<u>700-4050-7070-0000</u>		SPECIAL DEPT SUPPLIES		41.86	
<u>478766</u>	Invoice	11/21/2019	DEPARTMENT SUPPLIES - STREETS	0.00	7.26	
	<u>100-3250-7070-0000</u>		SPECIAL DEPT SUPPLIES		7.26	
<u>479131</u>	Invoice	11/21/2019	DEPARTMENT SUPPLIES - STREETS	0.00	3.88	
	<u>100-3250-7070-0000</u>		SPECIAL DEPT SUPPLIES		3.88	
<u>479373</u>	Invoice	11/20/2019	BUILDING SUPPLIES & MAINTENANCE	0.00	25.55	
	<u>100-6000-7085-6025</u>		BLDG MAINT - CITY HALL		25.55	
<u>479377</u>	Invoice	11/20/2019	BUILDING SUPPLIES & MAINTENANCE	0.00	33.93	
	<u>750-7300-7085-0000</u>		BUILDING SUPPLIES/MAI		33.93	
<u>479406</u>	Invoice	11/21/2019	DEPARTMENT SUPPLIES - STREETS	0.00	5.13	
	<u>100-3250-7070-0000</u>		SPECIAL DEPT SUPPLIES		5.13	

Check Report

Date Range: 11/15/2019 - 11/15/2019

2.

Vendor Number	Vendor Name	Payment Date	Payment Type	Discount Amount	Payment Amount	Num
<u>479417</u>	Invoice <u>100-3250-7070-0000</u>	11/21/2019	DEPARTMENT SUPPLIES - STREETS SPECIAL DEPT SUPPLIES	0.00	5.13	
<u>479425</u>	Invoice <u>100-3250-7070-0000</u>	11/21/2019	DEPARTMENT SUPPLIES - STREETS SPECIAL DEPT SUPPLIES	0.00	5.13	
<u>479545</u>	Invoice <u>100-3250-7070-0000</u>	11/21/2019	DEPARTMENT SUPPLIES - STREETS SPECIAL DEPT SUPPLIES	0.00	14.42	
<u>479760</u>	Invoice <u>100-2050-7025-0000</u>	11/20/2019	OFFICE SUPPLIES OFFICE SUPPLIES	0.00	1.73	
<u>479818</u>	Invoice <u>100-3250-7070-0000</u>	11/21/2019	DEPARTMENT SUPPLIES - STREETS SPECIAL DEPT SUPPLIES	0.00	9.69	
<u>479823</u>	Invoice <u>100-6000-7085-6055</u>	11/20/2019	BUILDING SUPPLIES & MAINTENANCE BLDG MAINT- FIRE STATIO	0.00	43.09	
<u>479824</u>	Invoice <u>100-6050-7070-5400</u>	11/20/2019	DEPT SUPPLIES SPEC DEPT EXP - SPORTS	0.00	62.82	
<u>479844</u>	Invoice <u>100-6000-7085-6055</u>	11/20/2019	BUILDING SUPPLIES & MAINTENANCE BLDG MAINT- FIRE STATIO	0.00	60.72	
<u>479847</u>	Invoice <u>100-6000-7085-6025</u>	11/20/2019	BUILDING SUPPLIES & MAINTENANCE BLDG MAINT - CITY HALL	0.00	25.69	
<u>479902</u>	Invoice <u>100-6000-7085-6029</u>	11/20/2019	BUILDING SUPPLIES & MAINTENANCE BLDG MAINT - CITY HALL	0.00	32.92	
<u>479912</u>	Invoice <u>100-6000-7085-6025</u>	11/20/2019	BUILDING SUPPLIES & MAINTENANCE BLDG MAINT - CITY HALL	0.00	6.77	
<u>480108</u>	Invoice <u>100-6000-7085-6040</u>	11/20/2019	BUILDING SUPPLIES & MAINTENANCE BLDG MAINT - POLICE DE	0.00	16.64	
<u>480200</u>	Invoice <u>100-6050-7070-5050</u>	11/20/2019	DEPT SUPPLIES SPEC DEPT EXP - DEFORG	0.00	48.61	
<u>480214</u>	Invoice <u>100-6050-7070-5400</u>	11/20/2019	DEPT SUPPLIES SPEC DEPT EXP - SPORTS	0.00	8.19	
<u>480264</u>	Invoice <u>100-6050-7070-5350</u>	11/20/2019	DEPT SUPPLIES SPEC DEPT EXP - SHADO	0.00	100.80	
1136	**Void** BEAUMONT POWER EQUIPMENT	11/21/2019	Regular	0.00	0.00	103945
Payable #	Account Type	Post Date	Payable Description	Discount Amount	Payable Amount	
<u>2617</u>	Invoice <u>100-6050-7090-0000</u> <u>100-6050-7090-0000</u>	11/20/2019	EQUIPMENT MAINTENANCE EQUIPMENT SUPPLIES/M EQUIPMENT SUPPLIES/M	0.00	42.29	
<u>2624</u>	Invoice <u>100-6050-7090-0000</u>	11/20/2019	EQUIPMENT MIANTENANCE EQUIPMENT SUPPLIES/M	0.00	10.00	
<u>2634</u>	Invoice <u>100-6050-7090-0000</u> <u>100-6050-7090-0000</u>	11/20/2019	EQUIPMENT SUPPLIES & MAINTENANCE EQUIPMENT SUPPLIES/M EQUIPMENT SUPPLIES/M	0.00	42.30	
<u>2652</u>	Invoice <u>100-6050-7090-0000</u>	11/20/2019	EQUIPMENT SUPPLIES & MAINTENANCE EQUIPMENT SUPPLIES/M	0.00	21.54	
<u>2656</u>	Invoice <u>100-6050-7090-0000</u>	11/20/2019	EQUIPMENT SUPPLIES & MAINTENANCE EQUIPMENT SUPPLIES/M	0.00	54.83	
<u>2660</u>	Invoice <u>100-6050-7090-0000</u>	11/20/2019	EQUIPMENT SUPPLIES & MAINTENANCE EQUIPMENT SUPPLIES/M	0.00	30.00	
1140	BEAUMONT SAFE & LOCK	11/21/2019	Regular	0.00	95.16	103947

Check Report

Date Range: 11/15/2019 - 11/21/2019

2.

Vendor Number	Vendor Name	Payment Date	Payment Type	Discount Amount	Payment Amount	Num
Payable #	Payable Type	Post Date	Payable Description	Discount Amount	Payable Amount	
	Account Number	Account Name	Item Description	Distribution Amount		
71776	Invoice	11/20/2019	BUILDING SUPPLIES & MAINTENANCE	0.00	95.16	
	<u>100-6000-7085-6045</u>		BLDG MAINT- COMMUNI		79.00	
	<u>100-6000-7085-6045</u>		BLDG MAINT- COMMUNI		16.16	
1161	BIO-TOX LABORATORIES	11/21/2019	Regular	0.00	258.00	103948
Payable #	Payable Type	Post Date	Payable Description	Discount Amount	Payable Amount	
	Account Number	Account Name	Item Description	Distribution Amount		
38845	Invoice	11/21/2019	Bio Tox Blood Draw Analysis	0.00	48.00	
	<u>100-2050-7068-0000</u>		CONTRACTUAL SERVICES		48.00	
38846	Invoice	11/21/2019	Bio Tox Blood Draw Analysis	0.00	210.00	
	<u>100-2050-7068-0000</u>		CONTRACTUAL SERVICES		210.00	
1190	CALIFORNIA ASSOCIATION OF CODE ENFORCEN	11/21/2019	Regular	0.00	95.00	103949
Payable #	Payable Type	Post Date	Payable Description	Discount Amount	Payable Amount	
	Account Number	Account Name	Item Description	Distribution Amount		
300011791	Invoice	11/20/2019	MEMBERSHIP DUES - JACK HUNTSMAN	0.00	95.00	
	<u>100-2030-7030-0000</u>		DUES & SUBSCRIPTIONS		95.00	
1190	CALIFORNIA ASSOCIATION OF CODE ENFORCEN	11/21/2019	Regular	0.00	95.00	103950
Payable #	Payable Type	Post Date	Payable Description	Discount Amount	Payable Amount	
	Account Number	Account Name	Item Description	Distribution Amount		
300011216	Invoice	11/20/2019	MEMBERSHIP DUES - KELLY McCARTHY	0.00	95.00	
	<u>100-2030-7030-0000</u>		DUES & SUBSCRIPTIONS		95.00	
3754	CALIFORNIA HAZARDOUS SERVICES, INC	11/21/2019	Regular	0.00	9,625.00	103951
Payable #	Payable Type	Post Date	Payable Description	Discount Amount	Payable Amount	
	Account Number	Account Name	Item Description	Distribution Amount		
65011	Invoice	11/21/2019	Fuel Filtering/Tank Cleaning	0.00	9,625.00	
	<u>700-4050-7090-0000</u>		EQUIPMENT SUPPLIES/M		4,740.00	
	<u>700-4050-7090-002X</u>		EQUIPMENT SUPPLIES/M		1,195.00	
	<u>700-4050-7090-003X</u>		EQUIPMENT SUPPLIES/M		750.00	
	<u>700-4050-7090-007A</u>		EQUIPMENT SUPPLIES/M		1,095.00	
	<u>700-4050-7090-019C</u>		EQUIPMENT SUPPLIES/M		1,095.00	
	<u>700-4050-7090-06A1</u>		EQUIPMENT SUPPLIES/M		750.00	
1208	CALIFORNIA PEACE OFFICERS ASSOC	11/21/2019	Regular	0.00	190.00	103952
Payable #	Payable Type	Post Date	Payable Description	Discount Amount	Payable Amount	
	Account Number	Account Name	Item Description	Distribution Amount		
206990	Invoice	11/20/2019	EMPLOYEE TRAINING	0.00	95.00	
	<u>100-2050-7066-0000</u>		TRAVEL, EDUCATION, TRA		95.00	
207500	Invoice	11/20/2019	EMPLOYEE TRAINING	0.00	95.00	
	<u>100-2050-7066-0000</u>		TRAVEL, EDUCATION, TRA		95.00	
3578	CALIFORNIA WATER ENVIRONMENT ASSOCIATI	11/21/2019	Regular	0.00	89.00	103953
Payable #	Payable Type	Post Date	Payable Description	Discount Amount	Payable Amount	
	Account Number	Account Name	Item Description	Distribution Amount		
0000191131	Invoice	11/21/2019	CERTIFICATE RENEWAL	0.00	89.00	
	<u>700-4050-7030-0000</u>		DUES & SUBSCRIPTIONS		89.00	
1227	CARROT-TOP INDUSTRIES INC	11/21/2019	Regular	0.00	544.64	103954
Payable #	Payable Type	Post Date	Payable Description	Discount Amount	Payable Amount	
	Account Number	Account Name	Item Description	Distribution Amount		
44246100	Invoice	11/20/2019	BUILDING SUPPLIES & MAINTENANCE	0.00	221.80	
	<u>100-6000-7085-6040</u>		BLDG MAINT - POLICE DE		221.80	
44246300	Invoice	11/20/2019	BUILDING SUPPLIES & MAINTENANCE	0.00	240.65	
	<u>100-6000-7085-6025</u>		BLDG MAINT - CITY HALL		240.65	
44276600	Invoice	11/20/2019	BUILDING SUPPLIES & MAINTENANCE	0.00	82.19	

Check Report

Date Range: 11/15/2019 - 11/15/2019

2.

Vendor Number	Vendor Name	Payment Date	Payment Type	Discount Amount	Payment Amount	Num
	<u>100-6000-7085-6025</u>	BLDG MAINT - CITY HALL	BUILDING SUPPLIES & MAINTEN		82.19	
1242	CED	11/21/2019	Regular	0.00	1,191.18	103955
<b>Payable #</b>	<b>Payable Type</b>	<b>Post Date</b>	<b>Payable Description</b>	<b>Discount Amount</b>	<b>Payable Amount</b>	
	<b>Account Number</b>		<b>Account Name</b>	<b>Item Description</b>	<b>Distribution Amount</b>	
<u>0954-473390</u>	Invoice	11/21/2019	DEPARTMENT SUPPLIES - ELECTRICAL	0.00	258.60	
	<u>100-3250-7070-0000</u>		SPECIAL DEPT SUPPLIES	DEPARTMENT SUPPLIES - ELECT	258.60	
<u>0954-473517</u>	Invoice	11/21/2019	DEPARTMENT SUPPLIES - ELECTRICAL	0.00	56.03	
	<u>100-3250-7070-0000</u>		SPECIAL DEPT SUPPLIES	DEPARTMENT SUPPLIES - ELECT	56.03	
<u>0954-474265</u>	Invoice	11/20/2019	BUILDING SUPPLIES & MAINTENANCE	0.00	101.03	
	<u>100-6000-7085-6045</u>		BLDG MAINT- COMMUNI	BUILDING SUPPLIES & MAINTEN	101.03	
<u>0954-474566</u>	Invoice	11/21/2019	DEPARTMENT SUPPLIES - ELECTRICAL	0.00	154.51	
	<u>100-3250-7070-0000</u>		SPECIAL DEPT SUPPLIES	DEPARTMENT SUPPLIES - ELECT	154.51	
<u>0954-474658</u>	Invoice	11/21/2019	DEPARTMENT SUPPLIES - ELECTRICAL	0.00	22.63	
	<u>100-3250-7070-0000</u>		SPECIAL DEPT SUPPLIES	DEPARTMENT SUPPLIES - ELECT	22.63	
<u>0954-474671</u>	Invoice	11/20/2019	BUILDING SUPPLIES & MAINTENANCE	0.00	57.01	
	<u>100-6000-7085-6040</u>		BLDG MAINT - POLICE DE	BUILDING SUPPLIES & MAINTEN	57.01	
<u>0954-474692</u>	Invoice	11/21/2019	DEPARTMENT SUPPLIES - ELECTRICAL	0.00	181.02	
	<u>100-3250-7070-0000</u>		SPECIAL DEPT SUPPLIES	DEPARTMENT SUPPLIES - ELECT	181.02	
<u>0954-474766</u>	Invoice	11/20/2019	DEPT SUPPLIES	0.00	52.20	
	<u>100-6050-7070-5700</u>		SPEC DEPT EXP - WILD FL	DEPT SUPPLIES	52.20	
<u>0954-474831</u>	Invoice	11/20/2019	DEPT SUPPLIES	0.00	170.77	
	<u>100-6050-7070-5700</u>		SPEC DEPT EXP - WILD FL	DEPT SUPPLIES	170.77	
<u>0954-474887</u>	Invoice	11/20/2019	BUILDING SUPPLIES & MAINTENANCE	0.00	137.38	
	<u>100-6000-7085-6025</u>		BLDG MAINT - CITY HALL	BUILDING SUPPLIES & MAINTEN	137.38	
1282	CINTAS CORPORATION #698	11/21/2019	Regular	0.00	714.77	103956
<b>Payable #</b>	<b>Payable Type</b>	<b>Post Date</b>	<b>Payable Description</b>	<b>Discount Amount</b>	<b>Payable Amount</b>	
	<b>Account Number</b>		<b>Account Name</b>	<b>Item Description</b>	<b>Distribution Amount</b>	
<u>4028237913</u>	Invoice	11/21/2019	UNIFORM MAINTENANCE	0.00	714.77	
	<u>100-6050-7065-0000</u>		UNIFORMS	UNIFORM MAINTENANCE	714.77	
1342	CR&R INC.	11/21/2019	Regular	0.00	8,718.60	103957
<b>Payable #</b>	<b>Payable Type</b>	<b>Post Date</b>	<b>Payable Description</b>	<b>Discount Amount</b>	<b>Payable Amount</b>	
	<b>Account Number</b>		<b>Account Name</b>	<b>Item Description</b>	<b>Distribution Amount</b>	
<u>0002141</u>	Invoice	11/21/2019	Street Sweeping Services	0.00	8,718.60	
	<u>100-3250-7068-0000</u>		CONTRACTUAL SERVICES	Street Sweeping Services	8,718.60	
1344	CREATIVE BUS SALES, INC	11/21/2019	Regular	0.00	707.43	103958
<b>Payable #</b>	<b>Payable Type</b>	<b>Post Date</b>	<b>Payable Description</b>	<b>Discount Amount</b>	<b>Payable Amount</b>	
	<b>Account Number</b>		<b>Account Name</b>	<b>Item Description</b>	<b>Distribution Amount</b>	
<u>5187786</u>	Invoice	11/20/2019	VEHICLE MAINTENANCE	0.00	707.43	
	<u>750-7400-7037-0000</u>		VEHICLE MAINTENANCE	VEHICLE MAINTENANCE	707.43	
1353	CUSTOM TROPHIES	11/21/2019	Regular	0.00	52.80	103959
<b>Payable #</b>	<b>Payable Type</b>	<b>Post Date</b>	<b>Payable Description</b>	<b>Discount Amount</b>	<b>Payable Amount</b>	
	<b>Account Number</b>		<b>Account Name</b>	<b>Item Description</b>	<b>Distribution Amount</b>	
<u>000785</u>	Invoice	11/20/2019	COMMUNITY EVENT	0.00	38.79	
	<u>100-1550-7046-0000</u>		SPECIAL COMMUNITY PR	COMMUNITY EVENT	38.79	
<u>000810</u>	Invoice	11/20/2019	OFFICE SUPPLIES	0.00	14.01	
	<u>100-2050-7025-0000</u>		OFFICE SUPPLIES	OFFICE SUPPLIES	14.01	
1391	DEKRA-LITE IND.,INC.	11/21/2019	Regular	0.00	1,334.99	103960



Check Report

Date Range: 11/15/2019 - 11/15/2019

2.

Vendor Number	Vendor Name	Payment Date	Payment Type	Discount Amount	Payment Amount	Num
Payable #	Payable Type	Post Date	Payable Description	Discount Amount	Payable Amount	
	Account Number	Account Name	Item Description	Distribution Amount		
SO058849	Invoice	11/20/2019	DEPT SUPPLIES	0.00	1,334.99	
	<u>100-1200-7070-0000</u>		SPECIAL DEPT SUPPLIES		1,334.99	
1402	DEPARTMENT OF JUSTICE	11/21/2019	Regular	0.00	1,091.00	103961
Payable #	Payable Type	Post Date	Payable Description	Discount Amount	Payable Amount	
	Account Number	Account Name	Item Description	Distribution Amount		
413031	Invoice	11/21/2019	Department of Justice - Livescan Fees	0.00	916.00	
	<u>100-2050-7031-0000</u>		LIVE SCAN-FINGERPRINTI		916.00	
418139	Invoice	11/21/2019	Department of Justice Blood Alcohol Anal	0.00	105.00	
	<u>100-2050-7068-0000</u>		CONTRACTUAL SERVICES		105.00	
418187	Invoice	11/21/2019	Department of Justice Blood Alcohol Anal	0.00	35.00	
	<u>100-2050-7068-0000</u>		CONTRACTUAL SERVICES		35.00	
418196	Invoice	11/21/2019	Department of Justice Blood Alcohol Anal	0.00	35.00	
	<u>100-2050-7068-0000</u>		CONTRACTUAL SERVICES		35.00	
3838	DEPARTMENT OF PESTICIDE REGULATION	11/21/2019	Regular	0.00	120.00	103962
Payable #	Payable Type	Post Date	Payable Description	Discount Amount	Payable Amount	
	Account Number	Account Name	Item Description	Distribution Amount		
132982-QUAL B	Invoice	11/20/2019	LICENSE FOR JOSE NUNEZ	0.00	120.00	
	<u>100-3250-7066-0000</u>		TRAVEL, EDUCATION, TRA		120.00	
1408	DEPARTMENT OF TRANSPORTATION	11/21/2019	Regular	0.00	3,216.10	103963
Payable #	Payable Type	Post Date	Payable Description	Discount Amount	Payable Amount	
	Account Number	Account Name	Item Description	Distribution Amount		
SL200117	Invoice	11/21/2019	SIGNALS & LIGHTING BILLING	0.00	3,216.10	
	<u>100-3250-7010-0000</u>		UTILITIES		3,216.10	
1414	DIAMOND HILLS AUTO GROUP	11/21/2019	Regular	0.00	338.10	103964
Payable #	Payable Type	Post Date	Payable Description	Discount Amount	Payable Amount	
	Account Number	Account Name	Item Description	Distribution Amount		
657901	Invoice	11/20/2019	VEHICLE MAINTENANCE	0.00	108.98	
	<u>750-7800-7037-0000</u>		VEHICLE MAINTENANCE		108.98	
657965	Invoice	11/20/2019	VEHICLE MAINTENANCE	0.00	229.12	
	<u>750-7800-7037-0000</u>		VEHICLE MAINTENANCE		229.12	
1422	DICK'S ALL AUTO REPAIR, INC	11/21/2019	Regular	0.00	362.25	103965
Payable #	Payable Type	Post Date	Payable Description	Discount Amount	Payable Amount	
	Account Number	Account Name	Item Description	Distribution Amount		
22705	Invoice	11/20/2019	VEHICLE MAINTENANCE	0.00	51.75	
	<u>100-2150-7037-0000</u>		VEHICLE MAINTENANCE		51.75	
22710	Invoice	11/20/2019	VEHICLE MAINTENANCE	0.00	51.75	
	<u>100-2150-7037-0000</u>		VEHICLE MAINTENANCE		51.75	
22715	Invoice	11/20/2019	VEHICLE MAINTENANCE	0.00	51.75	
	<u>100-6050-7037-0000</u>		VEHICLE MAINTENANCE		51.75	
22717	Invoice	11/20/2019	VEHICLE MAINTENANCE	0.00	51.75	
	<u>100-2030-7037-0000</u>		VEHICLE MAINTENANCE		51.75	
22721	Invoice	11/20/2019	VEHICLE MAINTENANCE	0.00	51.75	
	<u>100-6050-7037-0000</u>		VEHICLE MAINTENANCE		51.75	
22730	Invoice	11/20/2019	VEHICLE MAINTENANCE	0.00	51.75	
	<u>100-6050-7037-0000</u>		VEHICLE MAINTENANCE		51.75	
22749	Invoice	11/20/2019	VEHICLE MAINTENANCE	0.00	51.75	
	<u>100-6050-7037-0000</u>		VEHICLE MAINTENANCE		51.75	
3779	EDGAR L ALVAREZ	11/21/2019	Regular	0.00	480.00	103966

Check Report

Date Range: 11/15/2019 - 11/15/2019

2.

Vendor Number	Vendor Name	Payment Date	Payment Type	Discount Amount	Payment Amount	Num
Payable #	Payable Type	Post Date	Payable Description	Discount Amount	Payable Amount	
	Account Number	Account Name	Item Description	Distribution Amount		
004 CHECK 2	Invoice	11/20/2019	IT SERVICES	0.00	480.00	
	100-1230-7068-6040	CONTRACT SVC - P.D.	IT SERVICES		480.00	
3347	EXECUTIVE FACILITIES SERVICES, INC	11/21/2019	Regular	0.00	10,700.12	103967
Payable #	Payable Type	Post Date	Payable Description	Discount Amount	Payable Amount	
	Account Number	Account Name	Item Description	Distribution Amount		
20337	Invoice	11/21/2019	REMAKE OF PO 600000017	0.00	10,700.12	
	100-6000-7068-6025	CONTRACTUAL SVC - CITY	CITY HALL		3,915.50	
	100-6000-7068-6026	CONTRACTUAL SVC - CITY	BUILDING B		706.23	
	100-6000-7068-6032	CONTRACTUAL SVC - CITY	ANIMAL CONTROL		335.06	
	100-6000-7068-6040	CONTRACTUAL SVC - POLI	POLICE DEPT		947.38	
	100-6000-7068-6041	CONTRACTUAL SVC - POLI	POLICE ANNEX		552.38	
	100-6000-7068-6045	CONTRACTUAL SVC - COM	COMMUNITY CENTER		3,400.00	
	100-6000-7068-6060	CONTRACTUAL SVC - 713	MAINTENANCE YARD		179.23	
	750-7000-7068-0000	CONTRACTUAL SERVICES	TRANSIT BUILDING		539.34	
	750-7300-7068-0000	CONTRACTUAL SERVICES	TRANSIT MAINTENANCE YARD		125.00	
1501	FAIRVIEW FORD	11/21/2019	Regular	0.00	780.30	103968
Payable #	Payable Type	Post Date	Payable Description	Discount Amount	Payable Amount	
	Account Number	Account Name	Item Description	Distribution Amount		
641296	Invoice	11/20/2019	VEHICLE MAINTENANCE	0.00	22.81	
	750-7600-7037-0000	VEHICLE MAINTENANCE	VEHICLE MAINTENANCE		22.81	
641838	Invoice	11/20/2019	VEHICLE MAINTENANCE	0.00	75.60	
	750-7700-7037-0000	VEHICLE MAINTENANCE	VEHICLE MAINTENANCE		75.60	
644915	Invoice	11/20/2019	VEHICLE MAINTENANCE	0.00	251.38	
	750-7600-7037-0000	VEHICLE MAINTENANCE	VEHICLE MAINTENANCE		251.38	
648288	Invoice	11/20/2019	VEHICLE MAINTENANCE	0.00	430.51	
	750-7400-7037-0000	VEHICLE MAINTENANCE	VEHICLE MAINTENANCE		430.51	
1519	FORD MOTOR CREDIT CO.	11/21/2019	Regular	0.00	2,224.03	103969
Payable #	Payable Type	Post Date	Payable Description	Discount Amount	Payable Amount	
	Account Number	Account Name	Item Description	Distribution Amount		
1703815	Invoice	11/21/2019	Ford Motor Credit	0.00	2,224.03	
	100-2050-8060-0000	VEHICLES	Ford Motor Credit		2,224.03	
1533	FRONTIER COMMUNICATIONS	11/21/2019	Regular	0.00	817.50	103970
Payable #	Payable Type	Post Date	Payable Description	Discount Amount	Payable Amount	
	Account Number	Account Name	Item Description	Distribution Amount		
951-769-5188-04	Invoice	11/20/2019	PHONE UTILITY	0.00	367.08	
	100-1230-7015-6045	TELEPHONE (COMM CTR)	PHONE UTILITY		367.08	
951-769-8534-04	Invoice	11/20/2019	PHONE UTILITY	0.00	329.14	
	700-4050-7015-0000	TELEPHONE	PHONE UTILITY		329.14	
951-845-9839-09	Invoice	11/20/2019	PHONE UTILITY	0.00	121.28	
	100-1230-7015-6041	TELEPHONE (PD ANNEX)	PHONE UTILITY		121.28	
3795	GV CONSTRUCTION, INC	11/21/2019	Regular	0.00	39,943.90	103971
Payable #	Payable Type	Post Date	Payable Description	Discount Amount	Payable Amount	
	Account Number	Account Name	Item Description	Distribution Amount		
1007	Invoice	11/21/2019	CONSTRUCTION RENOVATION - COUNCIL	0.00	23,029.90	
	500-0000-8990-0000	CAPITAL OUTLAY	CONSTRUCTION RENOVATION -		23,029.90	
1008	Invoice	11/21/2019	DESIGN AND BUILD OF COUNCIL FURNITU	0.00	16,914.00	
	500-0000-8990-0000	CAPITAL OUTLAY	DESIGN AND BUILD OF COUNCIL		16,914.00	
3572	HECTOR ALVARADO	11/21/2019	Regular	0.00	4,310.00	103972



Check Report

Date Range: 11/15/2019 - 11/15/2019

2.

Vendor Number Payable #	Vendor Name Payable Type Account Number	Post Date	Payment Date Payable Description Account Name	Payment Type Item Description	Discount Amount Discount Amount	Payment Amount Payable Amount Distribution Amount	Num
1068	Invoice 750-7100-7068-0000 750-7400-7068-0000 750-7600-7068-0000 750-7700-7068-0000 750-7800-7068-0000 750-7900-7068-0000 750-8000-7068-0000 750-8100-7068-0000 750-8200-7068-0000	11/21/2019	Bus Washing Service		0.00	2,150.00	
			CONTRACTUAL SERVICES	VEHICLE MAINTENANCE		200.00	
			CONTRACTUAL EXPENSES	VEHICLE MAINTENANCE		480.00	
			CONTRACTUAL SERVICES	VEHICLE MAINTENANCE		330.00	
			CONTRACTUAL SERVICES	VEHICLE MAINTENANCE		300.00	
			CONTRACTUAL SERVICES	VEHICLE MAINTENANCE		130.00	
			CONTRACTUAL SERVICES	VEHICLE MAINTENANCE		130.00	
			CONTRACTUAL SERVICES	VEHICLE MAINTENANCE		100.00	
			CONTRACTUAL SERVICES	VEHICLE MAINTENANCE		320.00	
			CONTRACTUAL SERVICES	VEHICLE MAINTENANCE		160.00	
1088	Invoice 750-7100-7068-0000 750-7400-7068-0000 750-7600-7068-0000 750-7700-7068-0000 750-7800-7068-0000 750-7900-7068-0000 750-8000-7068-0000 750-8100-7068-0000 750-8200-7068-0000	11/21/2019	Bus Washing Service		0.00	2,160.00	
			CONTRACTUAL SERVICES	VEHICLE MAINTENANCE		200.00	
			CONTRACTUAL EXPENSES	VEHICLE MAINTENANCE		500.00	
			CONTRACTUAL SERVICES	VEHICLE MAINTENANCE		300.00	
			CONTRACTUAL SERVICES	VEHICLE MAINTENANCE		380.00	
			CONTRACTUAL SERVICES	VEHICLE MAINTENANCE		100.00	
			CONTRACTUAL SERVICES	VEHICLE MAINTENANCE		100.00	
			CONTRACTUAL SERVICES	VEHICLE MAINTENANCE		100.00	
			CONTRACTUAL SERVICES	VEHICLE MAINTENANCE		320.00	
			CONTRACTUAL SERVICES	VEHICLE MAINTENANCE		160.00	
1638	HOWARD'S Payable Type Account Number	11/21/2019	Regular		0.00	5,461.75	103973
3387	Invoice 100-2030-7039-0000	11/20/2019	WEED ABATEMENT SERVICES CODE ENFORCEMENT		0.00	3,471.00	
3406	Invoice 100-2030-7039-0000	11/20/2019	WEED ABATEMENT SERVICES CODE ENFORCEMENT		0.00	586.50	
3409	Invoice 100-2030-7039-0000	11/20/2019	WEED ABATEMENT SERVICES CODE ENFORCEMENT		0.00	636.00	
3410	Invoice 100-2030-7039-0000	11/20/2019	WEED ABATEMENT SERVICES CODE ENFORCEMENT		0.00	768.25	
3074	HUB CONSTRUCTION SPECIALTIES, INC Payable Type Account Number	11/21/2019	Regular		0.00	237.60	103974
4594795	Invoice 100-3250-7070-0000	11/20/2019	DEPT SUPPLIES SPECIAL DEPT SUPPLIES		0.00	237.60	
1643	HUNTINGTON COURT REPORTERS & TRANSCRI Payable Type Account Number	11/21/2019	Regular		0.00	519.24	103975
32472	Invoice 100-2050-7068-0000	11/21/2019	Transcription Services CONTRACTUAL SERVICES	Transcription Services	0.00	519.24	
2589	IDC CONSULTING ENGINEERS, INC Payable Type Account Number	11/21/2019	Regular		0.00	90,608.23	103976
215-18-10-004	Invoice 500-0000-7068-0000 500-0000-7068-0000	11/21/2019	Pennsylvania Grade Sep Engineering Desi CONTRACTUAL SERVICE CONTRACTUAL SERVICE	Pennsylvania Grade Sep Enginee PENNYLVANIA GRADING	0.00	90,608.23 78,108.23 12,500.00	
1657	IN GEAR TECHNOLOGY	11/21/2019	Regular		0.00	1,385.24	103977

Check Report

Date Range: 11/15/2019 - 11/19/2019

2.

Vendor Number	Vendor Name	Payment Date	Payment Type	Discount Amount	Payment Amount	Num
Payable #	Payable Type	Post Date	Payable Description	Discount Amount	Payable Amount	
	Account Number	Account Name	Item Description	Distribution Amount		
6205	Invoice	11/20/2019	VEHICLE MAINTENANCE	0.00	1,385.24	
	<u>100-2050-7037-0000</u>		VEHICLE MAINTENANCE		850.00	
	<u>100-2050-7037-0000</u>		VEHICLE MAINTENANCE		535.24	
1662	INFOSEND, INC	11/21/2019	Regular	0.00	11,018.41	103978
Payable #	Payable Type	Post Date	Payable Description	Discount Amount	Payable Amount	
	Account Number	Account Name	Item Description	Distribution Amount		
160219	Invoice	11/20/2019	PROFESSIONAL SERVICES	0.00	8,520.34	
	<u>700-4050-7068-0000</u>		CONTRACTUAL SERVICES		8,520.34	
161625	Invoice	11/20/2019	PROFESSIONAL SERVICES	0.00	2,323.07	
	<u>700-4050-7068-0000</u>		CONTRACTUAL SERVICES		2,323.07	
162313	Invoice	11/20/2019	PROGRAMMING FEE	0.00	175.00	
	<u>700-4050-7068-0000</u>		CONTRACTUAL SERVICES		175.00	
1675	INTERNATIONAL CODE COUNCIL, INC	11/21/2019	Regular	0.00	2,350.40	103979
Payable #	Payable Type	Post Date	Payable Description	Discount Amount	Payable Amount	
	Account Number	Account Name	Item Description	Distribution Amount		
0058100	Invoice	11/21/2019	ICC '19 California Code Book	0.00	2,350.40	
	<u>100-2150-7070-0000</u>		SPECIAL DEPT SUPPLIES		2,350.40	
3022	JENNIFER DARR	11/21/2019	Regular	0.00	40.00	103980
Payable #	Payable Type	Post Date	Payable Description	Discount Amount	Payable Amount	
	Account Number	Account Name	Item Description	Distribution Amount		
RCT 945714	Invoice	11/20/2019	DEPOSIT REFUND	0.00	40.00	
	<u>100-0000-4590-0000</u>		BUILDING RENTAL		40.00	
3223	JWC ENVIRONMENTAL INC	11/21/2019	Regular	0.00	7,041.61	103981
Payable #	Payable Type	Post Date	Payable Description	Discount Amount	Payable Amount	
	Account Number	Account Name	Item Description	Distribution Amount		
99816	Invoice	11/21/2019	DRIVE SHAFT ASSY, SWM-XE SST AT WWT	0.00	7,041.61	
	<u>700-4050-7090-0000</u>		EQUIPMENT SUPPLIES/M		7,041.61	
1805	KONICA MINOLTA BUSINESS SOLUTIONS	11/21/2019	Regular	0.00	123.92	103982
Payable #	Payable Type	Post Date	Payable Description	Discount Amount	Payable Amount	
	Account Number	Account Name	Item Description	Distribution Amount		
34306807	Invoice	11/20/2019	EQUIPMENT RENTAL	0.00	123.92	
	<u>100-1230-7090-6041</u>		EQUIP SUPPLIES/MAINT (		123.92	
1806	KONICA MINOLTA PREMIER FINANCE	11/21/2019	Regular	0.00	3,238.90	103983
Payable #	Payable Type	Post Date	Payable Description	Discount Amount	Payable Amount	
	Account Number	Account Name	Item Description	Distribution Amount		
399624287	Invoice	11/20/2019	EQUIPMENT RENTAL	0.00	3,238.90	
	<u>100-1230-7075-6025</u>		EQUIPMENT LEASING/RE		809.72	
	<u>100-1230-7075-6040</u>		EQUIPMENT LEASING/RE		809.72	
	<u>100-1230-7075-6045</u>		EQUIPMENT LEASING/RE		809.72	
	<u>750-7000-7075-0000</u>		EQUIPMENT LEASING/RE		809.74	
1827	LANGUAGE TESTING INTERNATIONAL	11/21/2019	Regular	0.00	70.00	103984
Payable #	Payable Type	Post Date	Payable Description	Discount Amount	Payable Amount	
	Account Number	Account Name	Item Description	Distribution Amount		
L31371-IN	Invoice	11/20/2019	HIRING COSTS	0.00	70.00	
	<u>100-1240-6050-0000</u>		RECRUITMENT AND HIRI		70.00	
1831	LAURA'S CUSTOM EMBROIDERY	11/21/2019	Regular	0.00	18.00	103985

Check Report

Date Range: 11/15/2019 - 11/15/2019

2.

Vendor Number	Vendor Name	Payment Date	Payment Type	Discount Amount	Payment Amount	Num
Payable #	Payable Type	Post Date	Payable Description	Discount Amount	Payable Amount	
	Account Number	Account Name	Item Description	Distribution Amount		
2500	Invoice	11/20/2019	EMBROIDERY FOR UNIFORM	0.00	18.00	
	100-2050-7065-0000	UNIFORMS	EMBROIDERY FOR UNIFORM		18.00	
1847	LEE'S AUTO BODY	11/21/2019	Regular	0.00	1,994.95	103986
Payable #	Payable Type	Post Date	Payable Description	Discount Amount	Payable Amount	
	Account Number	Account Name	Item Description	Distribution Amount		
2088	Invoice	11/20/2019	VEHICLE MAINTENANCE	0.00	1,994.95	
	100-2050-7037-0000	VEHICLE MAINTENANCE	VEHICLE MAINTENANCE		1,994.95	
1850	LESLIE'S SWIMMING POOL SUPPLIES	11/21/2019	Regular	0.00	106.66	103987
Payable #	Payable Type	Post Date	Payable Description	Discount Amount	Payable Amount	
	Account Number	Account Name	Item Description	Distribution Amount		
01062-02-002339	Invoice	11/20/2019	EQUIPMENT SUPPLIES	0.00	106.66	
	100-6050-7090-0000	EQUIPMENT SUPPLIES/M	EQUIPMENT SUPPLIES		106.66	
1856	LEXISNEXIS RISK SOLUTIONS	11/21/2019	Regular	0.00	171.70	103988
Payable #	Payable Type	Post Date	Payable Description	Discount Amount	Payable Amount	
	Account Number	Account Name	Item Description	Distribution Amount		
1535776-201910	Invoice	11/20/2019	MONTHLY SUBSCRIPTION FEE	0.00	171.70	
	100-2050-7030-0000	DUES & SUBSCRIPTIONS	MONTHLY SUBSCRIPTION FEE		171.70	
3683	MASTER'S COFFEE AND WATER	11/21/2019	Regular	0.00	56.99	103989
Payable #	Payable Type	Post Date	Payable Description	Discount Amount	Payable Amount	
	Account Number	Account Name	Item Description	Distribution Amount		
5-034820	Invoice	11/21/2019	OFFICE SUPPLIES	0.00	56.99	
	700-4050-7025-0000	OFFICE SUPPLIES	OFFICE SUPPLIES		56.99	
2619	MICHAEL DICK	11/21/2019	Regular	0.00	2,450.00	103990
Payable #	Payable Type	Post Date	Payable Description	Discount Amount	Payable Amount	
	Account Number	Account Name	Item Description	Distribution Amount		
0007	Invoice	11/20/2019	PROFESSIONAL SERVICES	0.00	1,000.00	
	100-6050-7068-06A1	CONTRACTUAL SVC IA 6A	PROFESSIONAL SERVICES		1,000.00	
0016	Invoice	11/20/2019	PROFESSIONAL SERVICES	0.00	1,450.00	
	100-6050-7068-06A1	CONTRACTUAL SVC IA 6A	PROFESSIONAL SERVICES		1,450.00	
3373	MIRIAM AVALOS	11/21/2019	Regular	0.00	475.00	103991
Payable #	Payable Type	Post Date	Payable Description	Discount Amount	Payable Amount	
	Account Number	Account Name	Item Description	Distribution Amount		
0069	Invoice	11/20/2019	VEHICLE MIANTENANCE	0.00	475.00	
	750-7600-7037-0000	VEHICLE MAINTENANCE	VEHICLE MIANTENANCE		475.00	
1984	NAPA AUTO PARTS	11/21/2019	Regular	0.00	1,565.91	103992
Payable #	Payable Type	Post Date	Payable Description	Discount Amount	Payable Amount	
	Account Number	Account Name	Item Description	Distribution Amount		
104370	Invoice	11/20/2019	VEHICLE MAINTENANCE	0.00	69.33	
	100-2050-7037-0000	VEHICLE MAINTENANCE	VEHICLE MAINTENANCE		69.33	
104771	Invoice	11/20/2019	VEHICLE MAINTENANCE	0.00	9.69	
	100-2150-7037-0000	VEHICLE MAINTENANCE	VEHICLE MAINTENANCE		9.69	
105418	Invoice	11/20/2019	VEHICLE MAINTENANCE	0.00	28.32	
	100-2050-7037-0000	VEHICLE MAINTENANCE	VEHICLE MAINTENANCE		28.32	
105644	Invoice	11/20/2019	VEHICLE MAINTENANCE	0.00	69.33	
	100-2050-7037-0000	VEHICLE MAINTENANCE	VEHICLE MAINTENANCE		69.33	
106117	Invoice	11/20/2019	VEHICLE MAINTENANCE	0.00	8.61	
	750-8100-7037-0000	VEHICLE MAINTENANCE	VEHICLE MAINTENANCE		8.61	
106124	Invoice	11/20/2019	VEHICLE MAINTENANCE	0.00	31.19	
	750-7300-7037-0000	VEHICLE MAINTENANCE	VEHICLE MAINTENANCE		31.19	

Check Report

Date Range: 11/15/2019 - 11/21/2019

2.

Vendor Number	Vendor Name	Payment Date	Payment Type	Discount Amount	Payment Amount	NU
<u>106165</u>	Invoice <u>100-2050-7037-0000</u>	11/20/2019	VEHICLE MAINTENANCE VEHICLE MAINTENANCE	0.00	13.90 13.90	
<u>106201</u>	Credit Memo <u>100-2050-7037-0000</u>	11/20/2019	VEHICLE MAINTENANCE VEHICLE MAINTENANCE	0.00	-207.82 -207.82	
<u>106251</u>	Invoice <u>750-7900-7037-0000</u>	11/20/2019	VEHICLE MAINTENANCE VEHICLE MAINTENANCE	0.00	7.52 7.52	
<u>106344</u>	Invoice <u>750-7800-7037-0000</u>	11/20/2019	VEHICLE MAINTENANCE VEHICLE MAINTENANCE	0.00	28.31 28.31	
<u>106354</u>	Invoice <u>750-7800-7037-0000</u>	11/20/2019	VEHICLE MAINTENANCE VEHICLE MAINTENANCE	0.00	87.98 87.98	
<u>106432</u>	Invoice <u>750-7600-7037-0000</u>	11/20/2019	VEHICLE MAINTENANCE VEHICLE MAINTENANCE	0.00	5.06 5.06	
<u>106588</u>	Invoice <u>750-7700-7037-0000</u>	11/20/2019	VEHICLE MAINTENANCE VEHICLE MAINTENANCE	0.00	113.67 113.67	
<u>106635</u>	Invoice <u>750-7300-7037-0000</u>	11/20/2019	VEHICLE MAINTENANCE VEHICLE MAINTENANCE	0.00	11.84 11.84	
<u>106670</u>	Invoice <u>750-7400-7037-0000</u>	11/20/2019	VEHICLE MAINTENANCE VEHICLE MAINTENANCE	0.00	290.88 290.88	
<u>106794</u>	Invoice <u>100-6050-7037-0000</u>	11/20/2019	VEHICLE MAINTENANCE VEHICLE MAINTENANCE	0.00	9.69 9.69	
<u>106806</u>	Credit Memo <u>750-7800-7037-0000</u>	11/20/2019	RETURNED PARTS VEHICLE MAINTENANCE	0.00	-87.98 -87.98	
<u>106942</u>	Invoice <u>750-7400-7037-0000</u>	11/20/2019	VEHICLE MAINTENANCE VEHICLE MAINTENANCE	0.00	11.30 11.30	
<u>107016</u>	Invoice <u>750-7400-7037-0000</u>	11/20/2019	VEHICLE MAINTENANCE VEHICLE MAINTENANCE	0.00	12.92 12.92	
<u>107101</u>	Invoice <u>750-8100-7037-0000</u>	11/20/2019	VEHICLE MAINTENANCE VEHICLE MAINTENANCE	0.00	391.48 391.48	
<u>107155</u>	Invoice <u>100-2150-7037-0000</u>	11/20/2019	VEHICLE MAINTENANCE VEHICLE MAINTENANCE	0.00	11.83 11.83	
<u>107195</u>	Invoice <u>750-8100-7037-0000</u>	11/20/2019	VEHICLE MAINTENANCE VEHICLE MAINTENANCE	0.00	38.77 38.77	
<u>107218</u>	Invoice <u>100-6050-7037-0000</u>	11/20/2019	VEHICLE MAINTENANCE VEHICLE MAINTENANCE	0.00	14.30 14.30	
<u>107238</u>	Invoice <u>100-6050-7037-0000</u>	11/20/2019	VEHICLE MAINTENANCE VEHICLE MAINTENANCE	0.00	80.13 80.13	
<u>107288</u>	Invoice <u>750-7400-7037-0000</u>	11/20/2019	VEHICLE MAINTENANCE VEHICLE MAINTENANCE	0.00	25.84 25.84	
<u>107424</u>	Invoice <u>750-7300-7037-0000</u>	11/20/2019	VEHICLE MAINTENANCE VEHICLE MAINTENANCE	0.00	10.76 10.76	
<u>107449</u>	Invoice <u>100-6050-7037-0000</u>	11/20/2019	VEHICLE MAINTENANCE VEHICLE MAINTENANCE	0.00	14.30 14.30	
<u>107485</u>	Invoice <u>750-7600-7037-0000</u>	11/20/2019	VEHICLE MAINTENANCE VEHICLE MAINTENANCE	0.00	179.12 179.12	
<u>107548</u>	Invoice <u>750-7400-7037-0000</u>	11/20/2019	VEHICLE MAINTENANCE VEHICLE MAINTENANCE	0.00	33.12 33.12	
<u>107595</u>	Invoice <u>750-7400-7037-0000</u>	11/20/2019	VEHICLE MAINTENANCE VEHICLE MAINTENANCE	0.00	38.77 38.77	
<u>107654</u>	Credit Memo <u>750-7800-7037-0000</u>	11/20/2019	RETURNED PARTS VEHICLE MAINTENANCE	0.00	-170.50 -170.50	
<u>107655</u>	Credit Memo <u>750-7800-7037-0000</u>	11/20/2019	RETURNED PARTS VEHICLE MAINTENANCE	0.00	-171.31 -171.31	

Check Report

Date Range: 11/15/2019 - 11/21/2019

2.

Vendor Number	Vendor Name	Payment Date	Payment Type	Discount Amount	Payment Amount	Num
<u>107696</u>	Invoice <u>750-7300-7037-0000</u>	11/20/2019	VEHICLE MAINTENANCE	0.00	59.22	
			VEHICLE MAINTENANCE		59.22	
<u>107728</u>	Invoice <u>750-7300-7037-0000</u>	11/20/2019	VEHICLE MAINTENANCE	0.00	23.68	
			VEHICLE MAINTENANCE		23.68	
<u>107738</u>	Invoice <u>750-7800-7037-0000</u>	11/20/2019	VEHICLE MAINTENANCE	0.00	59.22	
			VEHICLE MAINTENANCE		59.22	
<u>107901</u>	Invoice <u>100-6050-7037-0000</u>	11/20/2019	VEHICLE MAINTENANCE	0.00	12.92	
			VEHICLE MAINTENANCE		12.92	
<u>107993</u>	Invoice <u>750-7400-7037-0000</u>	11/20/2019	VEHICLE MAINTENANCE	0.00	17.22	
			VEHICLE MAINTENANCE		17.22	
<u>108116</u>	Invoice <u>100-6000-7070-6055</u>	11/20/2019	EQUIPMENT MAINTENANCE	0.00	101.20	
			SPEC DEPT EXP- FIRE STAT		101.20	
<u>108158</u>	Invoice <u>750-7700-7037-0000</u>	11/20/2019	VEHICLE MAINTENANCE	0.00	269.20	
			VEHICLE MAINTENANCE		269.20	
<u>108355</u>	Invoice <u>750-7300-7037-0000</u>	11/20/2019	VEHICLE MAINTENANCE	0.00	12.90	
			VEHICLE MAINTENANCE		12.90	

**Void**	11/21/2019	Regular	0.00	0.00	103993
**Void**	11/21/2019	Regular	0.00	0.00	103994
2009 O'REILLY AUTO PARTS	11/21/2019	Regular	0.00	553.79	103995

Payable #	Payable Type	Post Date	Payable Description	Discount Amount	Payable Amount	
Account Number	Account Name	Item Description	Distribution Amount			
<u>2678-222782</u>	Invoice <u>750-7800-7037-0000</u>	11/20/2019	VEHICLE MAINTENANCE	0.00	64.48	
			VEHICLE MAINTENANCE		64.48	
<u>2678-223037</u>	Credit Memo <u>750-7800-7037-0000</u>	11/20/2019	VEHICLE MAINTENANCE	0.00	-64.48	
			VEHICLE MAINTENANCE		-64.48	
<u>2678-223689</u>	Invoice <u>750-7100-7037-0000</u>	11/20/2019	VEHICLE MAINTENANCE	0.00	55.92	
			VEHICLE MAINTENANCE		55.92	
<u>2678-223960</u>	Invoice <u>750-7600-7037-0000</u>	11/20/2019	VEHICLE MAINTENANCE	0.00	42.39	
			VEHICLE MAINTENANCE		42.39	
<u>2678-224005</u>	Invoice <u>750-7400-7037-0000</u>	11/20/2019	VEHICLE MAINTENANCE	0.00	8.61	
			VEHICLE MAINTENANCE		8.61	
<u>2678-224354</u>	Credit Memo <u>750-7600-7037-0000</u>	11/20/2019	VEHICLE MAINTENANCE	0.00	-68.21	
			VEHICLE MAINTENANCE		-68.21	
<u>2678-225310</u>	Invoice <u>100-2030-7037-0000</u>	11/20/2019	VEHICLE MAINTENANCE	0.00	150.55	
			VEHICLE MAINTENANCE		150.55	
<u>2678-225412</u>	Invoice <u>100-6050-7037-0000</u>	11/20/2019	VEHICLE MAINTENANCE	0.00	21.46	
			VEHICLE MAINTENANCE		21.46	
<u>2678-225781</u>	Credit Memo <u>100-2030-7037-0000</u>	11/20/2019	VEHICLE MAINTENANCE	0.00	-132.60	
			VEHICLE MAINTENANCE		-132.60	
<u>2678-226292</u>	Invoice <u>750-8100-7037-0000</u>	11/20/2019	VEHICLE MAINTENANCE	0.00	42.29	
			VEHICLE MAINTENANCE		42.29	
<u>2678-226495</u>	Invoice <u>750-7300-7037-0000</u>	11/20/2019	VEHICLE MAINTENANCE	0.00	3.87	
			VEHICLE MAINTENANCE		3.87	
<u>2678-226822</u>	Invoice <u>100-6050-7037-0000</u>	11/20/2019	VEHICLE MAINTENANCE	0.00	66.31	
			VEHICLE MAINTENANCE		66.31	
<u>2678-226840</u>	Invoice <u>100-6050-7037-0000</u>	11/20/2019	VEHICLE MAINTENANCE	0.00	37.06	
			VEHICLE MAINTENANCE		37.06	
<u>2678-227948</u>	Invoice <u>750-7400-7037-0000</u>	11/20/2019	VEHICLE MAINTENANCE	0.00	362.14	
			VEHICLE MAINTENANCE		362.14	
<u>2678-227959</u>	Credit Memo <u>750-7400-7037-0000</u>	11/20/2019	VEHICLE MAINTENANCE	0.00	-36.00	
			VEHICLE MAINTENANCE		-36.00	

2039	PARKHOUSE TIRE, INC.	11/21/2019	Regular	0.00	1,480.48	103996
------	----------------------	------------	---------	------	----------	--------



Check Report

Date Range: 11/15/2019 - 11/21/2019

2.

Vendor Number	Vendor Name	Payment Date	Payment Type	Discount Amount	Payment Amount	Num
Payable #	Payable Type	Post Date	Payable Description	Discount Amount	Payable Amount	
	Account Number	Account Name	Item Description	Distribution Amount		
2030183417	Invoice	11/20/2019	VEHICLE MAINTENANCE	0.00	491.94	
	<u>750-7800-7037-0000</u>		VEHICLE MAINTENANCE		491.94	
2030183794	Invoice	11/20/2019	VEHICLE MAINTENANCE	0.00	750.38	
	<u>750-7400-7037-0000</u>		VEHICLE MAINTENANCE		750.38	
2030183903	Invoice	11/20/2019	VEHICLE MAINTENANCE	0.00	238.16	
	<u>100-6050-7037-0000</u>		VEHICLE MAINTENANCE		238.16	
3652	PRUDENTIAL OVERALL SUPPLY	11/21/2019	Regular	0.00	267.19	103997
Payable #	Payable Type	Post Date	Payable Description	Discount Amount	Payable Amount	
	Account Number	Account Name	Item Description	Distribution Amount		
22881002	Invoice	11/21/2019	Prudential Uniforms	0.00	68.75	
	<u>100-3250-7065-0000</u>		UNIFORMS		68.75	
22884625	Invoice	11/21/2019	Prudential Uniforms	0.00	68.75	
	<u>100-3250-7065-0000</u>		UNIFORMS		68.75	
22891736	Invoice	11/21/2019	Prudential Uniforms	0.00	60.94	
	<u>100-3250-7065-0000</u>		UNIFORMS		60.94	
22891738	Invoice	11/21/2019	Prudential Uniforms	0.00	68.75	
	<u>100-3250-7065-0000</u>		UNIFORMS		68.75	
2091	PURCHASE POWER-1183	11/21/2019	Regular	0.00	503.50	103998
Payable #	Payable Type	Post Date	Payable Description	Discount Amount	Payable Amount	
	Account Number	Account Name	Item Description	Distribution Amount		
8000-9000-0779-	Invoice	11/20/2019	POSTAGE	0.00	503.50	
	<u>100-2000-7025-0000</u>		OFFICE SUPPLIES		25.18	
	<u>100-2050-7025-0000</u>		OFFICE SUPPLIES		478.32	
2092	PURCHASE POWER-2540	11/21/2019	Regular	0.00	1,005.00	103999
Payable #	Payable Type	Post Date	Payable Description	Discount Amount	Payable Amount	
	Account Number	Account Name	Item Description	Distribution Amount		
8000-9000-0098-	Invoice	11/20/2019	POSTAGE	0.00	1,005.00	
	<u>100-1200-7068-0000</u>		CONTRACTUAL SERVICES		1,005.00	
2098	QUILL CORPORATON	11/21/2019	Regular	0.00	875.43	104000
Payable #	Payable Type	Post Date	Payable Description	Discount Amount	Payable Amount	
	Account Number	Account Name	Item Description	Distribution Amount		
2136829	Invoice	11/20/2019	OFFICE SUPPLIES	0.00	144.23	
	<u>100-1200-7025-0000</u>		OFFICE SUPPLIES		144.23	
2143026	Invoice	11/20/2019	OFFICE SUPPLIES	0.00	26.42	
	<u>100-1200-7025-0000</u>		OFFICE SUPPLIES		26.42	
2180334	Invoice	11/20/2019	OFFICE SUPPLIES	0.00	445.55	
	<u>100-1200-7025-0000</u>		OFFICE SUPPLIES		401.00	
	<u>100-3100-7025-0000</u>		OFFICE SUPPLIES		44.55	
2437814	Invoice	11/20/2019	OFFICE SUPPLIES	0.00	27.97	
	<u>100-1200-7025-0000</u>		OFFICE SUPPLIES		27.97	
2477793	Invoice	11/20/2019	OFFICE SUPPLIES	0.00	217.31	
	<u>100-1200-7025-0000</u>		OFFICE SUPPLIES		128.21	
	<u>100-3100-7025-0000</u>		OFFICE SUPPLIES		89.10	
2480976	Invoice	11/20/2019	OFFICE SUPPLIES	0.00	40.37	
	<u>100-1200-7025-0000</u>		OFFICE SUPPLIES		40.37	
753050	Credit Memo	11/20/2019	OFFICE SUPPLIES	0.00	-26.42	
	<u>100-1200-7025-0000</u>		OFFICE SUPPLIES		-26.42	
2104	RAMONA HUMANE SOCIETY INC	11/21/2019	Regular	0.00	4,750.14	104001

Check Report

Date Range: 11/15/2019 - 11/15/2019

2.

Vendor Number	Vendor Name	Payment Date	Payment Type	Discount Amount	Payment Amount	NU
Payable #	Payable Type	Post Date	Payable Description	Discount Amount	Payable Amount	
	Account Number	Account Name	Item Description	Distribution Amount		
COB10312 10/01	Invoice <u>100-2000-7068-0000</u>	11/21/2019	Ramona Humane Society - Sheltering Serv CONTRACTUAL SERVICES Ramona Humane Society - Shelt	0.00	4,750.14	
3514	RECYCLED AGGREGATE MATERIALS CO, INC	11/21/2019	Regular	0.00	160.00	104002
Payable #	Payable Type	Post Date	Payable Description	Discount Amount	Payable Amount	
	Account Number	Account Name	Item Description	Distribution Amount		
341065	Invoice <u>100-3250-7070-0000</u>	11/21/2019	DEPARTMENT SUPPLIES - STREETS SPECIAL DEPT SUPPLIES Street Repairs	0.00	160.00	
2135	RESOURCE BUILDING MATERIALS	11/21/2019	Regular	0.00	755.86	104003
Payable #	Payable Type	Post Date	Payable Description	Discount Amount	Payable Amount	
	Account Number	Account Name	Item Description	Distribution Amount		
2713177	Invoice <u>100-6050-7070-5750</u>	11/20/2019	DEPT SUPPLIES SPECIAL DEPT SUPPLIES ( DEPT SUPPLIES	0.00	558.68	
2716960	Invoice <u>100-6050-7070-5750</u>	11/20/2019	DEPT SUPPLIES SPECIAL DEPT SUPPLIES ( DEPT SUPPLIES	0.00	197.18	
2170	RIVERSIDE COUNTY SHERIFF DEPARTMENT	11/21/2019	Regular	0.00	108.00	104004
Payable #	Payable Type	Post Date	Payable Description	Discount Amount	Payable Amount	
	Account Number	Account Name	Item Description	Distribution Amount		
04/09/20	Invoice <u>100-2090-7066-0000</u>	11/20/2019	DISPATCHER ROLE/CRITICAL INCIDENTS TRAVEL, EDUCATION, TRA DISPATCHER ROLE/CRITICAL INC	0.00	108.00	
2196	ROBERTSON'S	11/21/2019	Regular	0.00	359.00	104005
Payable #	Payable Type	Post Date	Payable Description	Discount Amount	Payable Amount	
	Account Number	Account Name	Item Description	Distribution Amount		
512976	Invoice <u>100-3250-7070-0000</u>	11/21/2019	CONCRETE SPECIAL DEPT SUPPLIES CONCRETE	0.00	359.00	
2205	ROSEMARY OUIROZ	11/21/2019	Regular	0.00	40.00	104006
Payable #	Payable Type	Post Date	Payable Description	Discount Amount	Payable Amount	
	Account Number	Account Name	Item Description	Distribution Amount		
RCT 942581	Invoice <u>100-0000-4590-0000</u>	11/20/2019	DEPOSIT REFUND BUILDING RENTAL DEPOSIT REFUND	0.00	40.00	
2209	ROW TRAFFIC SAFETY INC	11/21/2019	Regular	0.00	302.24	104007
Payable #	Payable Type	Post Date	Payable Description	Discount Amount	Payable Amount	
	Account Number	Account Name	Item Description	Distribution Amount		
16497	Invoice <u>100-6050-7070-0000</u>	11/20/2019	DEPT SUPPLIES SPECIAL DEPT SUPPLIES DEPT SUPPLIES	0.00	302.24	
1113	RYAN M. WESTBROOK INC	11/21/2019	Regular	0.00	113.35	104008
Payable #	Payable Type	Post Date	Payable Description	Discount Amount	Payable Amount	
	Account Number	Account Name	Item Description	Distribution Amount		
687573	Invoice <u>100-2000-7068-0000</u>	11/20/2019	ANIMAL CARE SERVICES CONTRACTUAL SERVICES ANIMAL CARE SERVICES	0.00	50.00	
688219	Invoice <u>100-2000-7068-0000</u>	11/20/2019	ANIMAL CARE SERVICES CONTRACTUAL SERVICES ANIMAL CARE SERVICES	0.00	63.35	
3822	SAFETYNET INC	11/21/2019	Regular	0.00	702.30	104009
Payable #	Payable Type	Post Date	Payable Description	Discount Amount	Payable Amount	
	Account Number	Account Name	Item Description	Distribution Amount		
66861	Invoice <u>100-6050-7066-0000</u> <u>750-7300-7066-0000</u>	11/21/2019	EMPLOYEE TRAINING TRAVEL, EDUCATION, TRA EMPLOYEE TRAINING TRAVEL, EDUCATION, TRA EMPLOYEE TRAINING	0.00	702.30	
2257	SCOTT FAZEKAS & ASSOCIATES, INC.	11/21/2019	Regular	0.00	8,626.72	104010



Check Report

Date Range: 11/15/2019 - 11/15/2019

2.

Vendor Number	Vendor Name	Payment Date	Payment Type	Discount Amount	Payment Amount	Num
Payable #	Payable Type	Post Date	Payable Description	Discount Amount	Payable Amount	
	Account Number	Account Name	Item Description	Distribution Amount		
20832	Invoice	11/21/2019	FY 19-20 PO for Plan Check Services	0.00	7,966.72	
	<u>100-2150-7063-0000</u>	PLAN CHECK FEES	FY 19-20 PO for Plan Check Serv		7,966.72	
20833	Invoice	11/21/2019	FY 19-20 PO for Plan Check Services	0.00	660.00	
	<u>100-2150-7063-0000</u>	PLAN CHECK FEES	FY 19-20 PO for Plan Check Serv		660.00	
2261	SEAN THUILIEZ	11/21/2019	Regular	0.00	834.95	104011
Payable #	Payable Type	Post Date	Payable Description	Discount Amount	Payable Amount	
	Account Number	Account Name	Item Description	Distribution Amount		
<u>04/20/20-04/23/</u>	Invoice	11/20/2019	CHIEFS ANNUAL SYMPOSIUM	0.00	834.95	
	<u>100-2050-7066-0000</u>	TRAVEL, EDUCATION, TRA	CHIEFS ANNUAL SYMPOSIUM		834.95	
2281	SHRED-IT	11/21/2019	Regular	0.00	366.69	104012
Payable #	Payable Type	Post Date	Payable Description	Discount Amount	Payable Amount	
	Account Number	Account Name	Item Description	Distribution Amount		
<u>8128440876</u>	Invoice	11/20/2019	PROFESSIONAL SERVICES	0.00	366.69	
	<u>100-1200-7068-0000</u>	CONTRACTUAL SERVICES	PROFESSIONAL SERVICES		366.69	
3031	SMARTHIRE	11/21/2019	Regular	0.00	368.10	104013
Payable #	Payable Type	Post Date	Payable Description	Discount Amount	Payable Amount	
	Account Number	Account Name	Item Description	Distribution Amount		
<u>47906</u>	Invoice	11/20/2019	HIRING COSTS	0.00	368.10	
	<u>100-1240-6050-0000</u>	RECRUITMENT AND HIRI	HIRING COSTS		368.10	
2329	ST. FRANCIS ELECTRIC	11/21/2019	Regular	0.00	2,185.58	104014
Payable #	Payable Type	Post Date	Payable Description	Discount Amount	Payable Amount	
	Account Number	Account Name	Item Description	Distribution Amount		
<u>1660590</u>	Invoice	11/21/2019	TRAFFIC SIGNAL MAINTENANCE & EMER	0.00	1,120.00	
	<u>100-3250-7068-0000</u>	CONTRACTUAL SERVICES	TRAFFIC SIGNAL MAINTENANCE		1,120.00	
<u>1660591</u>	Invoice	11/21/2019	TRAFFIC SIGNAL MAINTENANCE & EMER	0.00	1,065.58	
	<u>100-3250-7068-0000</u>	CONTRACTUAL SERVICES	TRAFFIC SIGNAL MAINTENANCE		1,065.58	
2331	STAGECOACH TOWING	11/21/2019	Regular	0.00	40.25	104015
Payable #	Payable Type	Post Date	Payable Description	Discount Amount	Payable Amount	
	Account Number	Account Name	Item Description	Distribution Amount		
<u>19-27089</u>	Invoice	11/20/2019	VEHICLE MAINTENANCE	0.00	40.25	
	<u>100-6050-7037-0000</u>	VEHICLE MAINTENANCE	VEHICLE MAINTENANCE		40.25	
2374	SWRCB ACCOUNTING OFFICE	11/21/2019	Regular	0.00	2,625.00	104016
Payable #	Payable Type	Post Date	Payable Description	Discount Amount	Payable Amount	
	Account Number	Account Name	Item Description	Distribution Amount		
<u>WD-0164462</u>	Invoice	11/21/2019	ANNUAL PERMIT FEE	0.00	2,625.00	
	<u>700-4050-7022-0000</u>	LICENSE, PERMITS, FEES	ANNUAL PERMIT FEE		2,625.00	
3473	TANISHA HERRERA	11/21/2019	Regular	0.00	40.00	104017
Payable #	Payable Type	Post Date	Payable Description	Discount Amount	Payable Amount	
	Account Number	Account Name	Item Description	Distribution Amount		
<u>RCT 946245</u>	Invoice	11/20/2019	DEPOSIT REFUND	0.00	40.00	
	<u>100-0000-4590-0000</u>	BUILDING RENTAL	DEPOSIT REFUND		40.00	
2395	TERMINIX COMMERCIAL	11/21/2019	Regular	0.00	273.00	104018
Payable #	Payable Type	Post Date	Payable Description	Discount Amount	Payable Amount	
	Account Number	Account Name	Item Description	Distribution Amount		
<u>390829890</u>	Invoice	11/20/2019	BUILDING MAINTENANCE	0.00	80.00	
	<u>100-6000-7085-6040</u>	BLDG MAINT - POLICE DE	BUILDING MAINTENANCE		80.00	
<u>391016719</u>	Invoice	11/20/2019	BUILDING MAINTENANCE	0.00	60.00	
	<u>100-6000-7085-6055</u>	BLDG MAINT- FIRE STATIO	BUILDING MAINTENANCE		60.00	
<u>391284029</u>	Invoice	11/20/2019	BUILDING MAINTENANCE	0.00	133.00	

Check Report

Date Range: 11/15/2019 - 11/15/2019

2.

Vendor Number	Vendor Name	Payment Date	Payment Type	Discount Amount	Payment Amount	Num
	<u>100-6000-7085-6025</u>	11/21/2019	Regular	0.00	133.00	104019
	BLDG MAINT - CITY HALL		BUILDING MAINTENANCE			
2405	THE COUNSELING TEAM	11/21/2019	Regular	0.00	2,093.75	104019
<b>Payable #</b>	<b>Payable Type</b>	<b>Post Date</b>	<b>Payable Description</b>	<b>Discount Amount</b>	<b>Payable Amount</b>	
	<b>Account Number</b>		<b>Account Name</b>		<b>Distribution Amount</b>	
<u>73605</u>	Invoice	11/20/2019	PROFESSIONAL SERVICES	0.00	1,093.75	
	<u>100-1240-7068-0000</u>		CONTRACTUAL SERVICES		1,093.75	
<u>73617</u>	Invoice	11/20/2019	EMPLOYEE SUPPORT SERVICES	0.00	1,000.00	
	<u>100-1240-7068-0000</u>		CONTRACTUAL SERVICES		1,000.00	
2416	THE PRESS-ENTERPRISE	11/21/2019	Regular	0.00	340.20	104020
<b>Payable #</b>	<b>Payable Type</b>	<b>Post Date</b>	<b>Payable Description</b>	<b>Discount Amount</b>	<b>Payable Amount</b>	
	<b>Account Number</b>		<b>Account Name</b>		<b>Distribution Amount</b>	
<u>0011325749</u>	Invoice	11/20/2019	ADVERTISING COSTS	0.00	64.80	
	<u>100-3100-7020-0000</u>		ADVERTISING		64.80	
<u>0011326754</u>	Invoice	11/20/2019	ADVERTISING	0.00	55.80	
	<u>100-3100-7020-0000</u>		ADVERTISING		55.80	
<u>0011327626</u>	Invoice	11/20/2019	ADVERTISING	0.00	70.20	
	<u>100-1350-7020-0000</u>		ADVERTISING		70.20	
<u>0011330406</u>	Invoice	11/20/2019	ADVERTISING	0.00	73.80	
	<u>100-1350-7020-0000</u>		ADVERTISING		73.80	
<u>0011330407</u>	Invoice	11/20/2019	ADVERTISING	0.00	75.60	
	<u>100-1350-7020-0000</u>		ADVERTISING		75.60	
2429	THYSSENKRUPP ELEVATOR CORP	11/21/2019	Regular	0.00	1,193.36	104021
<b>Payable #</b>	<b>Payable Type</b>	<b>Post Date</b>	<b>Payable Description</b>	<b>Discount Amount</b>	<b>Payable Amount</b>	
	<b>Account Number</b>		<b>Account Name</b>		<b>Distribution Amount</b>	
<u>3004897718</u>	Invoice	11/20/2019	BUILDING MAINTENANCE	0.00	1,193.36	
	<u>100-6000-7085-6045</u>		BLDG MAINT- COMMUNI		1,193.36	
2442	TOP-LINE INDUSTRIAL SUPPLY	11/21/2019	Regular	0.00	14.67	104022
<b>Payable #</b>	<b>Payable Type</b>	<b>Post Date</b>	<b>Payable Description</b>	<b>Discount Amount</b>	<b>Payable Amount</b>	
	<b>Account Number</b>		<b>Account Name</b>		<b>Distribution Amount</b>	
<u>418045</u>	Invoice	11/21/2019	VEHICLE MAINTENANCE	0.00	7.47	
	<u>750-7900-7037-0000</u>		VEHICLE MAINTENANCE		7.47	
<u>418744</u>	Invoice	11/20/2019	VEHICLE MAINTENANCE	0.00	0.93	
	<u>750-7700-7037-0000</u>		VEHICLE MAINTENANCE		0.93	
<u>418752</u>	Invoice	11/20/2019	VEHICLE MAINTENANCE	0.00	6.27	
	<u>750-7800-7037-0000</u>		VEHICLE MAINTENANCE		6.27	
2651	TSR CONSTRUCTION AND INSPECTION	11/21/2019	Regular	0.00	57,000.00	104023
<b>Payable #</b>	<b>Payable Type</b>	<b>Post Date</b>	<b>Payable Description</b>	<b>Discount Amount</b>	<b>Payable Amount</b>	
	<b>Account Number</b>		<b>Account Name</b>		<b>Distribution Amount</b>	
<u>1</u>	Invoice	11/21/2019	Rangel Prk improvement project 2018-00	0.00	8,550.00	
	<u>215-0000-8020-0000</u>		LAND IMPROVEMENTS		8,550.00	
<u>2</u>	Invoice	11/21/2019	Rangel Prk improvement project 2018-00	0.00	48,450.00	
	<u>215-0000-8020-0000</u>		LAND IMPROVEMENTS		48,450.00	
2455	TURBOSCAPE, INC.	11/21/2019	Regular	0.00	6,320.00	104024
<b>Payable #</b>	<b>Payable Type</b>	<b>Post Date</b>	<b>Payable Description</b>	<b>Discount Amount</b>	<b>Payable Amount</b>	
	<b>Account Number</b>		<b>Account Name</b>		<b>Distribution Amount</b>	
<u>9943</u>	Invoice	11/21/2019	brown mulch for Brookside project	0.00	6,320.00	
	<u>100-6050-7068-014A</u>		CONTRACTUAL SVC IA 14		6,320.00	
2472	UPS	11/21/2019	Regular	0.00	3.95	104025

Check Report

Date Range: 11/15/2019 - 11/15/2019

2.

Vendor Number Payable #	Vendor Name Payable Type Account Number	Post Date	Payment Date Payable Description Account Name Item Description	Payment Type	Discount Amount Discount Amount Distribution Amount	Payment Amount Payable Amount Payable Amount	Num
000087R790459	Invoice 100-1230-7070-0000	11/20/2019	SHIPPING SERVICES SPECIAL DEPT SUPPLIES SHIPPING SERVICES		0.00	3.95 3.95	
2516 Payable #	VOHNE LICHE KENNELS INC Payable Type Account Number	11/21/2019	Regular Payable Description Account Name Item Description		0.00	125.00 125.00	104026
16145	Invoice 100-2080-7066-0000	11/20/2019	K9 TRAINING TRAVEL, EDUCATION, TRA K9 TRAINING		0.00	125.00 125.00	
2518 Payable #	VULCAN MATERIALS Payable Type Account Number	11/21/2019	Regular Payable Description Account Name Item Description		0.00	301.27 301.27	104027
72392951	Invoice 100-3250-7070-0000	11/21/2019	ASPHALT & SUPPLIES SPECIAL DEPT SUPPLIES ASPHALT & SUPPLIES		0.00	150.27 150.27	
72406210	Invoice 100-3250-7070-0000	11/21/2019	ASPHALT & SUPPLIES SPECIAL DEPT SUPPLIES ASPHALT & SUPPLIES		0.00	151.00 151.00	
3422 Payable #	WAXIE SANITARY SUPPLY Payable Type Account Number	11/21/2019	Regular Payable Description Account Name Item Description		0.00	149.92 149.92	104028
78636655	Invoice 100-6000-7085-6032 100-6000-7085-6040 100-6000-7085-6041	11/21/2019	BUILDING SUPPLIES BLDG MAINT- CITY HALL B BUILDING SUPPLIES BLDG MAINT - POLICE DE BUILDING SUPPLIES BLDG MAINT - POLICE AN BUILDING SUPPLIES		0.00	149.92 14.99 119.94 14.99	
2536 Payable #	WELDORS SUPPLY AND STEEL CO Payable Type Account Number	11/21/2019	Regular Payable Description Account Name Item Description		0.00	117.28 117.28	104029
10955	Invoice 100-6050-7085-0000	11/20/2019	BUILDING MAINTENANCE BUILDING SUPPLIES/MAI BUILDING MAINTENANCE		0.00	117.28 117.28	
3599 Payable #	WESTERN MUNICIPAL WATER DISTRICT Payable Type Account Number	11/21/2019	Regular Payable Description Account Name Item Description		0.00	13,748.90 13,748.90	104030
R13384	Invoice 700-4050-7089-0000	11/21/2019	NOVEMBER 2019 - INLAND EMPIRE BRINE BRINE LINE MAINTENANC NOVEMBER 2019 - INLAND EMP		0.00	13,748.90 13,748.90	
2546 Payable #	WILLDAN ENGINEERING Payable Type Account Number	11/21/2019	Regular Payable Description Account Name Item Description		0.00	39,516.25 39,516.25	104031
002-21698	Invoice 100-2150-7067-0000 100-2150-7067-0000	11/21/2019	FY 19-20 PO for Insepction Services INSPECTIONS INSPECTION SERVICES INSPECTIONS FY 19-20 PO for Insepction Servi		0.00	28,890.00 27,890.00 1,000.00	
002-21699	Invoice 100-2150-7063-0000	11/21/2019	FY19-20 Willdan PO for Plan Check Servic PLAN CHECK FEES FY19-20 Willdan PO for Plan Ch		0.00	10,626.25 10,626.25	
3254 Payable #	WOOD ENVIRONMENT & INFRASTRUCTURE SO Payable Type Account Number	11/21/2019	Regular Payable Description Account Name Item Description		0.00	1,317.12 1,317.12	104032
S44142162	Invoice 710-0000-7068-0000	11/21/2019	BIOLOGICAL RESOURCE ASSISTANCE TO P CONTRACTUAL SERVICE BIOLOGICAL RESOURCE ASSISTA		0.00	1,317.12 1,317.12	
2556 Payable #	XYLEM WATER SOLUTIONS, INC Payable Type Account Number	11/21/2019	Regular Payable Description Account Name Item Description		0.00	8,047.92 8,047.92	104033
3556A93331	Invoice 700-4050-7090-0000	11/21/2019	PUMP REPAIR AT THE WWTP EQUIPMENT SUPPLIES/M PUMP REPAIR AT THE WWTP		0.00	8,047.92 8,047.92	

Check Report

Date Range: 11/15/2019 - 11/21/2019

2.

Vendor Number	Vendor Name	Payment Date	Payment Type	Discount Amount	Payment Amount	Num
2559	YORK INSURANCE SERVICES GROUP, INC	11/21/2019	Regular	0.00	9,216.25	104034
Payable #	Payable Type	Post Date	Payable Description	Discount Amount	Payable Amount	
<u>500019349</u>	Invoice	11/21/2019	York / Sedgwick - Wokers Comp Administr	0.00	9,216.25	
	<u>100-1240-7068-0000</u>		CONTRACTUAL SERVICES York / Sedgwick - Wokers Comp		9,216.25	
2946	Z & K CONSULTANTS, INC.	11/21/2019	Regular	0.00	8,580.00	104035
Payable #	Payable Type	Post Date	Payable Description	Discount Amount	Payable Amount	
<u>102 10/31/19</u>	Invoice	11/21/2019	PROFESSIONAL ENGINEERING SERVICES	0.00	8,580.00	
	<u>100-3100-7068-0000</u>		CONTRACTUAL SERVICES PROFESSIONAL ENGINEERING S		8,580.00	

Bank Code APBNK Summary

Payment Type	Payable Count	Payment Count	Discount	Payment
Regular Checks	250	102	0.00	410,802.78
Manual Checks	0	0	0.00	0.00
Voided Checks	0	3	0.00	0.00
Bank Drafts	0	0	0.00	0.00
EFT's	0	0	0.00	0.00
	<b>250</b>	<b>105</b>	<b>0.00</b>	<b>410,802.78</b>

### All Bank Codes Check Summary

Payment Type	Payable Count	Payment Count	Discount	Payment
Regular Checks	250	102	0.00	410,802.78
Manual Checks	0	0	0.00	0.00
Voided Checks	0	3	0.00	0.00
Bank Drafts	0	0	0.00	0.00
EFT's	0	0	0.00	0.00
	250	105	0.00	410,802.78

### Fund Summary

Fund	Name	Period	Amount
999	POOLED CASH	11/2019	410,802.78
			410,802.78



**WARRANTS TO BE RATIFIED**

Tuesday, November 26, 2019

<b>Printed Checks</b>	104036-104091	\$	609,443.28	FY 19/20
<b>ACH</b>	227-232	\$	5,811,730.79	✓
	A/P Total	\$	<u>6,421,174.07</u>	

<b>Bank Drafts</b>	Deluxe Bus Systems	\$	734.39	Deposit bags and books
--------------------	--------------------	----	--------	------------------------

I DO HEREBY CERTIFY THIS WARRANT LIST HAS BEEN COMPILED AND PREPARED TO MEET THE DAILY OPERATIONS FOR THE FISCAL YEAR JULY 1, 2019 - JUNE 30, 2020

SIGNATURE:   
 TITLE: CITY TREASURER

SIGNATURE:   
 TITLE: ADMINISTRATIVE SERVICES DIRECTOR



Vendor Number	Vendor Name	Payment Date	Payment Type	Discount Amount	Payment Amount	Number
3229	ICMA - RC	11/26/2019	EFT	0.00	14,745.55	227
<b>Payable #</b>	<b>Payable Type</b>	<b>Post Date</b>	<b>Payable Description</b>	<b>Discount Amount</b>	<b>Payable Amount</b>	
<u>PD 11/08/19-11/</u>	Invoice	11/26/2019	EMPLOYEE CONTRIBUTIONS	0.00	14,745.55	
	<u>100-0000-2075-0000</u>		DEFERRED COMPENSATI		10,430.10	
	<u>100-0000-2075-0000</u>		DEFERRED COMPENSATI		224.74	
	<u>100-1200-6026-0000</u>		DEFERRED COMP		4,090.71	
2264	SEIU	11/26/2019	EFT	0.00	3,347.60	228
<b>Payable #</b>	<b>Payable Type</b>	<b>Post Date</b>	<b>Payable Description</b>	<b>Discount Amount</b>	<b>Payable Amount</b>	
<u>PD 11/08/19-11/</u>	Invoice	11/26/2019	EMPLOYEE DUES	0.00	3,347.60	
	<u>100-0000-2061-0000</u>		P.E.R.C. DUES & INS		3,347.60	
2295	SLOVAK BARON EMPEY MURPHY & PINKNEY	11/26/2019	EFT	0.00	113,965.57	229
<b>Payable #</b>	<b>Payable Type</b>	<b>Post Date</b>	<b>Payable Description</b>	<b>Discount Amount</b>	<b>Payable Amount</b>	
<u>55357</u>	Invoice	11/26/2019	LEGAL SERVICES	0.00	58,200.64	
	<u>120-9663-7300-0000</u>		CONTRACTUAL SERVICES		58,200.64	
<u>55358</u>	Invoice	11/26/2019	LEGAL SERVICES	0.00	82.50	
	<u>120-9663-7300-0000</u>		CONTRACTUAL SERVICES		82.50	
<u>55359</u>	Invoice	11/26/2019	LEGAL SERVICES	0.00	4,535.00	
	<u>120-9663-7300-0000</u>		CONTRACTUAL SERVICES		4,535.00	
<u>55360</u>	Invoice	11/26/2019	LEGAL SERVICES	0.00	1,265.00	
	<u>120-9663-7300-0000</u>		CONTRACTUAL SERVICES		1,265.00	
<u>55361</u>	Invoice	11/26/2019	LEGAL SERVICES	0.00	2,534.00	
	<u>120-9663-7300-0000</u>		CONTRACTUAL SERVICES		2,534.00	
<u>55362</u>	Invoice	11/26/2019	LEGAL SERVICES	0.00	2,082.00	
	<u>120-9663-7300-0000</u>		CONTRACTUAL SERVICES		2,082.00	
<u>55363</u>	Invoice	11/26/2019	LEGAL SERVICES	0.00	10,537.30	
	<u>120-9663-7300-0000</u>		CONTRACTUAL SERVICES		10,537.30	
<u>55364</u>	Invoice	11/26/2019	LEGAL SERVICES	0.00	3,859.00	
	<u>120-9663-7300-0000</u>		CONTRACTUAL SERVICES		3,859.00	
<u>55365</u>	Invoice	11/26/2019	LEGAL SERVICES	0.00	165.00	
	<u>120-9663-7300-0000</u>		CONTRACTUAL SERVICES		165.00	
<u>55366</u>	Invoice	11/26/2019	LEGAL SERVICES	0.00	78.00	
	<u>120-9663-7300-0000</u>		CONTRACTUAL SERVICES		78.00	
<u>55367</u>	Invoice	11/26/2019	LEGAL SERVICES	0.00	3,822.50	
	<u>120-9663-7300-0000</u>		CONTRACTUAL SERVICES		3,822.50	
<u>55368</u>	Invoice	11/26/2019	LEGAL SERVICES	0.00	1,000.00	
	<u>120-9663-7300-0000</u>		CONTRACTUAL SERVICES		1,000.00	
<u>55369</u>	Invoice	11/26/2019	LEGAL SERVICES	0.00	16,132.50	
	<u>120-9663-7300-0000</u>		CONTRACTUAL SERVICES		16,132.50	
<u>55370</u>	Invoice	11/26/2019	LEGAL SERVICES	0.00	7,592.68	
	<u>120-9663-7300-0000</u>		CONTRACTUAL SERVICES		7,592.68	
<u>55371</u>	Invoice	11/26/2019	LEGAL SERVICES	0.00	2,079.45	
	<u>120-9663-7300-0000</u>		CONTRACTUAL SERVICES		2,079.45	
3400	T.E. ROBERTS, INC	11/26/2019	EFT	0.00	1,177,218.36	230



Vendor Number	Vendor Name	Payment Date	Payment Type	Discount Amount	Payment Amount	Num
Payable #	Payable Type	Post Date	Payable Description	Discount Amount	Payable Amount	
	Account Number	Account Name	Item Description	Distribution Amount		
<u>APPLICATION 10</u>	Invoice	11/26/2019	Brine Line Reach 2 - Contractor	0.00	1,177,218.36	
	<u>710-0000-8030-0000</u>	CAPITAL IMPROVEMENT	BRINE LINE REACH 2		14,300.00	
	<u>710-0000-8030-0000</u>	CAPITAL IMPROVEMENT	Brine Line Reach 2 - Contractor		1,162,918.36	
3396	W.M. LYLES CO.	11/26/2019	EFT	0.00	3,501,477.25	231
<u>Payable #</u>	<u>Payable Type</u>	<u>Post Date</u>	<u>Payable Description</u>	<u>Discount Amount</u>	<u>Payable Amount</u>	
<u>Account Number</u>	<u>Account Name</u>	<u>Item Description</u>	<u>Distribution Amount</u>			
<u>APPLICATION 11</u>	Invoice	11/26/2019	WWTP SALT MITIGATION UPGRADE - CON	0.00	3,501,477.25	
	<u>710-0000-8030-0000</u>	CAPITAL IMPROVEMENT	WWTP SALT MITIGATION UPGR		596,031.05	
	<u>710-0000-8030-0000</u>	CAPITAL IMPROVEMENT	WWTP SALT MITIGATION UPGR		5,351,386.18	
	<u>710-0000-8030-0000</u>	CAPITAL IMPROVEMENT	WWTP SALT MITIGATION		81,128.29	
	<u>710-0000-8030-0000</u>	CAPITAL IMPROVEMENT	WWTP SALT MITIGATION UPGR		138,531.73	
	<u>710-0000-8030-0000</u>	CAPITAL IMPROVEMENT	RETENTION		-2,665,600.00	
3394	WEKA INC	11/26/2019	EFT	0.00	1,000,976.46	232
<u>Payable #</u>	<u>Payable Type</u>	<u>Post Date</u>	<u>Payable Description</u>	<u>Discount Amount</u>	<u>Payable Amount</u>	
<u>Account Number</u>	<u>Account Name</u>	<u>Item Description</u>	<u>Distribution Amount</u>			
<u>APPLICATION 11</u>	Invoice	11/26/2019	Brine Line Reach 1 - Contractor	0.00	1,000,976.46	
	<u>710-0000-8030-0000</u>	CAPITAL IMPROVEMENT	Brine Line Reach 1 - Contractor		890,581.56	
	<u>710-0000-8030-0000</u>	CAPITAL IMPROVEMENT	BRINE LINE		110,394.90	
1036	ALBERT A. WEBB ASSOCIATES	11/26/2019	Regular	0.00	147,902.78	104036 ✓
<u>Payable #</u>	<u>Payable Type</u>	<u>Post Date</u>	<u>Payable Description</u>	<u>Discount Amount</u>	<u>Payable Amount</u>	
<u>Account Number</u>	<u>Account Name</u>	<u>Item Description</u>	<u>Distribution Amount</u>			
<u>194575</u>	Invoice	11/26/2019	Engineering Services During Construction	0.00	95,938.68	
	<u>710-0000-7068-0000</u>	CONTRACTUAL SERVICE	Engineering Services During Con		95,938.68	
<u>194576</u>	Invoice	11/26/2019	Engineering Services During Const. - BRIN	0.00	17,728.44	
	<u>710-0000-7068-0000</u>	CONTRACTUAL SERVICE	Engineering Services During Con		17,728.44	
<u>194577</u>	Invoice	11/26/2019	Engineering Services During Construction	0.00	8,550.31	
	<u>710-0000-7068-0000</u>	CONTRACTUAL SERVICE	Engineering Services During Con		8,550.31	
<u>194577-2</u>	Invoice	11/26/2019	Engineering Services During Const. - BRIN	0.00	7,283.60	
	<u>710-0000-7068-0000</u>	CONTRACTUAL SERVICE	Engineering Services During Con		7,283.60	
<u>194613</u>	Invoice	11/26/2019	PERMITTING ASSISTANCE FOR THE AQMD	0.00	3,157.50	
	<u>710-0000-7068-0000</u>	CONTRACTUAL SERVICE	PERMITTING ASSISTANCE FOR T		3,157.50	
<u>194614</u>	Invoice	11/26/2019	TITLE 22 ENGINEER'S REPORT FOR WWTP	0.00	2,425.00	
	<u>710-0000-7068-0000</u>	CONTRACTUAL SERVICE	TITLE 22 ENGINEER'S REPORT F		2,425.00	
<u>194615</u>	Invoice	11/26/2019	NPDES PERMIT APPLICATION FOR WWTP	0.00	12,819.25	
	<u>710-0000-8030-0000</u>	CAPITAL IMPROVEMENT	NPDES PERMIT APPLICATION FO		12,819.25	
1042	ALL PURPOSE RENTALS	11/26/2019	Regular	0.00	48.40	104037
<u>Payable #</u>	<u>Payable Type</u>	<u>Post Date</u>	<u>Payable Description</u>	<u>Discount Amount</u>	<u>Payable Amount</u>	
<u>Account Number</u>	<u>Account Name</u>	<u>Item Description</u>	<u>Distribution Amount</u>			
<u>39546</u>	Invoice	11/26/2019	EQUIPMENT RENTAL	0.00	48.40	
	<u>100-6050-7075-014X</u>	EQUIPMENT LEASING/RE	EQUIPMENT RENTAL		48.40	
1050	AMAZON CAPITAL SERVICES	11/26/2019	Regular	0.00	32.89	104038
<u>Payable #</u>	<u>Payable Type</u>	<u>Post Date</u>	<u>Payable Description</u>	<u>Discount Amount</u>	<u>Payable Amount</u>	
<u>Account Number</u>	<u>Account Name</u>	<u>Item Description</u>	<u>Distribution Amount</u>			
<u>1T7G-YW1X-3JQJ</u>	Invoice	11/26/2019	EQUIPMENT MAINTENANCE	0.00	32.89	
	<u>100-1550-7070-0000</u>	SPECIAL DEPT SUPPLIES	EQUIPMENT MAINTENANCE		10.81	
	<u>100-6150-7090-0000</u>	EQUIPMENT SUPPLIES/M	EQUIPMENT MAINTENANCE		22.08	
3685	ANDREW J EVANS	11/26/2019	Regular	0.00	675.00	104039

Check Report

Date Range: 11/22/2019 - 11/26/2019

2.

Vendor Number	Vendor Name	Payment Date	Payment Type	Discount Amount	Payment Amount	Num
Payable #	Payable Type	Post Date	Payable Description	Discount Amount	Payable Amount	
	Account Number	Account Name	Item Description	Distribution Amount		
<u>507298</u>	Invoice	11/26/2019	EQUIPMENT MIANTENANCE	0.00	450.00	
	<u>100-6000-7090-6045</u>		EQUIPMENT SUPPLIES/M		450.00	
<u>507300</u>	Invoice	11/26/2019	EQUIPMENT MIANTENANCE	0.00	225.00	
	<u>100-6000-7090-6025</u>		EQUIPMENT SUPPLIES/M		225.00	
3661	ARROWHEAD GROUP INC	11/26/2019	Regular	0.00	120.00	104040
<u>Payable #</u>	<u>Payable Type</u>	<u>Post Date</u>	<u>Payable Description</u>	<u>Discount Amount</u>	<u>Payable Amount</u>	
<u>22129</u>	Invoice	11/26/2019	Backflow Testing and Repair	0.00	120.00	
	<u>100-6050-7068-5999</u>		CONTRACT SVC - ALL PAR		120.00	
3129	BC RENTALS, INC	11/26/2019	Regular	0.00	214.87	104041
<u>Payable #</u>	<u>Payable Type</u>	<u>Post Date</u>	<u>Payable Description</u>	<u>Discount Amount</u>	<u>Payable Amount</u>	
<u>0044179-IN</u>	Invoice	11/26/2019	DEPT SUPPLIES	0.00	214.87	
	<u>700-4050-7070-0000</u>		SPECIAL DEPT SUPPLIES		214.87	
1127	BEAUMONT DO IT BEST HOME CENTER	11/26/2019	Regular	0.00	39.37	104042
<u>Payable #</u>	<u>Payable Type</u>	<u>Post Date</u>	<u>Payable Description</u>	<u>Discount Amount</u>	<u>Payable Amount</u>	
<u>479074</u>	Invoice	11/26/2019	DEPT SUPPLIES	0.00	6.10	
	<u>750-7600-7070-0000</u>		SPECIAL DEPT SUPPLIES		6.10	
<u>480462</u>	Invoice	11/26/2019	BUILDING MAINTENANCE	0.00	33.27	
	<u>100-6000-7085-6025</u>		BLDG MAINT - CITY HALL		33.27	
1139	BEAUMONT POLICE OFFICERS ASSOCIATION	11/26/2019	Regular	0.00	5,370.00	104043
<u>Payable #</u>	<u>Payable Type</u>	<u>Post Date</u>	<u>Payable Description</u>	<u>Discount Amount</u>	<u>Payable Amount</u>	
<u>PD 11/08/19-11/</u>	Invoice	11/26/2019	POLICE DUES	0.00	5,370.00	
	<u>100-0000-2035-0000</u>		C.O.P.S. DUES		5,370.00	
1181	BRITTANY RODRIGUEZ	11/26/2019	Regular	0.00	40.00	104044
<u>Payable #</u>	<u>Payable Type</u>	<u>Post Date</u>	<u>Payable Description</u>	<u>Discount Amount</u>	<u>Payable Amount</u>	
<u>RCT 945451</u>	Invoice	11/26/2019	DEPOSIT REFUND	0.00	40.00	
	<u>100-0000-4590-0000</u>		BUILDING RENTAL		40.00	
3602	BURRTEC WASTE GROUP, INC	11/26/2019	Regular	0.00	42,592.63	104045
<u>Payable #</u>	<u>Payable Type</u>	<u>Post Date</u>	<u>Payable Description</u>	<u>Discount Amount</u>	<u>Payable Amount</u>	
<u>11052019-2</u>	Invoice	11/26/2019	Sludge Hauling Services for the WWTP	0.00	42,592.63	
	<u>700-4050-7068-0000</u>		CONTRACTUAL SERVICES		4,755.05	
	<u>700-4050-7068-0000</u>		CONTRACTUAL SERVICES		37,837.58	
1190	CALIFORNIA ASSOCIATION OF CODE ENFORCEM	11/26/2019	Regular	0.00	86.00	104046
<u>Payable #</u>	<u>Payable Type</u>	<u>Post Date</u>	<u>Payable Description</u>	<u>Discount Amount</u>	<u>Payable Amount</u>	
<u>200010896</u>	Invoice	11/26/2019	EMPLOYEE TRAINING	0.00	43.00	
	<u>100-2030-7066-0000</u>		TRAVEL, EDUCATION, TRA		43.00	
<u>200010897</u>	Invoice	11/26/2019	EMPLOYEE TRAINING	0.00	43.00	
	<u>100-2030-7066-0000</u>		TRAVEL, EDUCATION, TRA		43.00	
3780	CDCE INCORPORATED	11/26/2019	Regular	0.00	24,033.72	104047
<u>Payable #</u>	<u>Payable Type</u>	<u>Post Date</u>	<u>Payable Description</u>	<u>Discount Amount</u>	<u>Payable Amount</u>	
<u>136175</u>	Invoice	11/26/2019	Purchase of 6 Panasonic Tough Books and	0.00	24,033.72	
	<u>220-0000-7072-0000</u>		COMPUTER SUPPLIES/MA		24,033.72	

Check Report

Date Range: 11/22/2019 - 11/26/2019

2.

Vendor Number	Vendor Name	Payment Date	Payment Type	Discount Amount	Payment Amount	Num
1250	CHAMBERS GROUP, INC	11/26/2019	Regular	0.00	1,941.50	104048
<b>Payable #</b>	<b>Payable Type</b>	<b>Post Date</b>	<b>Payable Description</b>	<b>Discount Amount</b>	<b>Payable Amount</b>	
<u>33808</u>	Invoice	11/26/2019	Environmental Review PP2019-0222	0.00	1,941.50	
	<u>100-1350-7068-0000</u>		CONTRACTUAL SERVICES		1,941.50	
1279	CIGNA HEALTH CARE	11/26/2019	Regular	0.00	54,323.78	104049
<b>Payable #</b>	<b>Payable Type</b>	<b>Post Date</b>	<b>Payable Description</b>	<b>Discount Amount</b>	<b>Payable Amount</b>	
<u>2563997</u>	Invoice	11/26/2019	EMP INSURANCE	0.00	54,323.78	
	<u>100-0000-2299-0000</u>		COBRA RECEIPTS		2,157.42	
	<u>100-1200-6020-0000</u>		HEALTH INSURANCE		2,286.86	
	<u>100-1225-6020-0000</u>		HEALTH INSURANCE		2,157.42	
	<u>100-1230-6020-0000</u>		HEALTH INSURANCE		2,847.80	
	<u>100-1550-6020-0000</u>		HEALTH INSURANCE		1,725.94	
	<u>100-2030-6020-0000</u>		HEALTH INSURANCE		3,149.84	
	<u>100-2050-6020-0000</u>		HEALTH INSURANCE		12,901.36	
	<u>100-2090-6020-0000</u>		HEALTH INSURANCE		4,875.74	
	<u>100-3100-6020-0000</u>		HEALTH INSURANCE		2,157.42	
	<u>100-3250-6020-0000</u>		HEALTH INSURANCE		1,423.90	
	<u>100-6050-6020-0000</u>		HEALTH INSURANCE		8,888.56	
	<u>700-4050-6020-0000</u>		HEALTH INSURANCE		5,177.80	
	<u>750-7000-6020-0000</u>		HEALTH INSURANCE		1,423.90	
	<u>750-7300-6020-0000</u>		HEALTH INSURANCE		862.96	
	<u>750-7400-6020-0000</u>		HEALTH INSURANCE		2,286.86	
3839	COASTAL BUSINESS GROUP	11/26/2019	Regular	0.00	1,519.06	104050
<b>Payable #</b>	<b>Payable Type</b>	<b>Post Date</b>	<b>Payable Description</b>	<b>Discount Amount</b>	<b>Payable Amount</b>	
<u>CUP2019-0031</u>	Invoice	11/26/2019	REFUND OF APPLICATION FEES	0.00	1,519.06	
	<u>100-0000-4556-0000</u>		PLANNING DEPARTMENT		1,519.06	
1310	COLONIAL LIFE	11/26/2019	Regular	0.00	578.92	104051
<b>Payable #</b>	<b>Payable Type</b>	<b>Post Date</b>	<b>Payable Description</b>	<b>Discount Amount</b>	<b>Payable Amount</b>	
<u>CD 11/08/19-11/</u>	Invoice	11/26/2019	OPTIONAL INSURANCE	0.00	578.92	
	<u>100-0000-2051-0000</u>		COLONIAL INS-WITHHOL		578.92	
3653	CONTRON	11/26/2019	Regular	0.00	1,786.80	104052
<b>Payable #</b>	<b>Payable Type</b>	<b>Post Date</b>	<b>Payable Description</b>	<b>Discount Amount</b>	<b>Payable Amount</b>	
<u>11987</u>	Invoice	11/26/2019	TECHNICAL SERVICES FOR SCADA WW SYS	0.00	893.40	
	<u>700-4050-7068-0000</u>		CONTRACTUAL SERVICES		893.40	
<u>11988</u>	Invoice	11/26/2019	TECHNICAL SERVICES FOR SCADA WW SYS	0.00	893.40	
	<u>700-4050-7068-0000</u>		CONTRACTUAL SERVICES		893.40	
1424	DIRECTV	11/26/2019	Regular	0.00	178.23	104053
<b>Payable #</b>	<b>Payable Type</b>	<b>Post Date</b>	<b>Payable Description</b>	<b>Discount Amount</b>	<b>Payable Amount</b>	
<u>36903631625</u>	Invoice	11/26/2019	BUILDING UTILITY	0.00	178.23	
	<u>100-6000-7010-6045</u>		UTILITIES - COMMUNITY		178.23	
3560	DOSSIER SYSTEMS INC	11/26/2019	Regular	0.00	1,710.00	104054
<b>Payable #</b>	<b>Payable Type</b>	<b>Post Date</b>	<b>Payable Description</b>	<b>Discount Amount</b>	<b>Payable Amount</b>	
<u>44893-2</u>	Invoice	11/26/2019	Fleet Maintenance Software & Solutions	0.00	1,710.00	
	<u>750-7300-7071-0000</u>		SOFTWARE		1,710.00	
	<u>760-0000-8040-0000</u>		EQUIPMENT		17,556.00	
	<u>760-0000-8040-0000</u>		EQUIPMENT		-17,556.00	

Check Report

Date Range: 11/22/2019 - 11/22/2019

2.

Vendor Number	Vendor Name	Payment Date	Payment Type	Discount Amount	Payment Amount	Num
1445	DUDEK	11/26/2019	Regular	0.00	1,885.00	104055
<b>Payable #</b>	<b>Payable Type</b>	<b>Post Date</b>	<b>Payable Description</b>	<b>Discount Amount</b>	<b>Payable Amount</b>	
<u>20197988</u>	Invoice	11/26/2019	Max Benefit Report of Groundwater & Sur	0.00	1,885.00	
	<u>700-4050-7068-0000</u>		CONTRACTUAL SERVICES		1,885.00	
3840	ERIN SCHELL	11/26/2019	Regular	0.00	46.30	104056
<b>Payable #</b>	<b>Payable Type</b>	<b>Post Date</b>	<b>Payable Description</b>	<b>Discount Amount</b>	<b>Payable Amount</b>	
<u>07-008312-04</u>	Invoice	11/26/2019	REFUND FOR PAYMENT MADE AFTER ESC	0.00	46.30	
	<u>100-0000-1400-0000</u>		A/R - UTILITIES		46.30	
3841	FALIN WARD	11/26/2019	Regular	0.00	40.00	104057
<b>Payable #</b>	<b>Payable Type</b>	<b>Post Date</b>	<b>Payable Description</b>	<b>Discount Amount</b>	<b>Payable Amount</b>	
<u>RCT 946836</u>	Invoice	11/26/2019	DEPOSIT REFUND	0.00	40.00	
	<u>100-0000-4590-0000</u>		BUILDING RENTAL		40.00	
1522	FOX OCCUPATIONAL	11/26/2019	Regular	0.00	465.00	104058
<b>Payable #</b>	<b>Payable Type</b>	<b>Post Date</b>	<b>Payable Description</b>	<b>Discount Amount</b>	<b>Payable Amount</b>	
<u>112825</u>	Invoice	11/26/2019	HIRING COSTS	0.00	465.00	
	<u>100-1240-6050-0000</u>		RECRUITMENT AND HIRI		465.00	
1533	FRONTIER COMMUNICATIONS	11/26/2019	Regular	0.00	417.91	104059
<b>Payable #</b>	<b>Payable Type</b>	<b>Post Date</b>	<b>Payable Description</b>	<b>Discount Amount</b>	<b>Payable Amount</b>	
<u>213-180-1992-06</u>	Invoice	11/26/2019	PHONE UTILITY	0.00	178.63	
	<u>100-1230-7015-6045</u>		TELEPHONE (COMM CTR)		178.63	
<u>951-769-8537-03</u>	Invoice	11/26/2019	PHONE UTILITY	0.00	103.00	
	<u>100-1230-7015-6060</u>		TELEPHONE (4th ST YARD)		103.00	
<u>951-922-6646-04</u>	Invoice	11/26/2019	PHONE UTILITY	0.00	136.28	
	<u>700-4050-7015-0000</u>		TELEPHONE		136.28	
1554	GALLADE CHEMICAL, INC.	11/26/2019	Regular	0.00	1,411.53	104060
<b>Payable #</b>	<b>Payable Type</b>	<b>Post Date</b>	<b>Payable Description</b>	<b>Discount Amount</b>	<b>Payable Amount</b>	
<u>1084139</u>	Invoice	11/26/2019	CHEMICALS FOR WWTP	0.00	1,411.53	
	<u>700-4050-7070-0000</u>		SPECIAL DEPT SUPPLIES		1,411.53	
1603	HACH COMPANY	11/26/2019	Regular	0.00	1,405.18	104061 ✓
<b>Payable #</b>	<b>Payable Type</b>	<b>Post Date</b>	<b>Payable Description</b>	<b>Discount Amount</b>	<b>Payable Amount</b>	
<u>11703752</u>	Invoice	11/26/2019	SPECIAL DEPARTMENT SUPPLIES - WW	0.00	1,405.18	
	<u>700-4050-7070-0000</u>		SPECIAL DEPT SUPPLIES		1,405.18	
1679	INTERWEST CONSULTING GRP, INC.	11/26/2019	Regular	0.00	5,876.25	104062
<b>Payable #</b>	<b>Payable Type</b>	<b>Post Date</b>	<b>Payable Description</b>	<b>Discount Amount</b>	<b>Payable Amount</b>	
<u>54798</u>	Invoice	11/26/2019	FY19-20 PO for Plan Check Services	0.00	5,876.25	
	<u>100-2150-7063-0000</u>		PLAN CHECK FEES		5,876.25	
3842	IRINA IONESCU	11/26/2019	Regular	0.00	40.00	104063 ✓
<b>Payable #</b>	<b>Payable Type</b>	<b>Post Date</b>	<b>Payable Description</b>	<b>Discount Amount</b>	<b>Payable Amount</b>	
<u>RCT 947518</u>	Invoice	11/26/2019	DEPOSIT REFUND	0.00	40.00	
	<u>100-0000-4590-0000</u>		BUILDING RENTAL		40.00	
3843	JASON COILLOT	11/26/2019	Regular	0.00	81.56	104064

Check Report

Date Range: 11/22/2019 - 11/26/2019

2.

Vendor Number	Vendor Name	Payment Date	Payment Type	Discount Amount	Payment Amount	Num
Payable #	Payable Type	Post Date	Payable Description	Discount Amount	Payable Amount	
	Account Number	Account Name	Item Description	Distribution Amount		
07-074122-02	Invoice	11/26/2019	REIMBURSE CREDIT ON ACCOUNT	0.00	81.56	
	<a href="#">100-0000-1400-0000</a>	A/R - UTILITIES	REIMBURSE CREDIT ON ACCOU		81.56	
1773	KAISER FOUNDATION HEALTH PLAN	11/26/2019	Regular	0.00	138,900.89	104065
Payable #	Payable Type	Post Date	Payable Description	Discount Amount	Payable Amount	
	Account Number	Account Name	Item Description	Distribution Amount		
<a href="#">DECEMBER 2019</a>	Invoice	11/26/2019	HEALTH INSURANCE	0.00	138,900.89	
	<a href="#">100-1200-6020-0000</a>	HEALTH INSURANCE	EMPLOYEE HEALTH INSURANCE		6,676.77	
	<a href="#">100-1225-6020-0000</a>	HEALTH INSURANCE	EMPLOYEE HEALTH INSURANCE		2,980.72	
	<a href="#">100-1230-6020-0000</a>	HEALTH INSURANCE	EMPLOYEE HEALTH INSURANCE		1,788.41	
	<a href="#">100-1240-6020-0000</a>	HEALTH INSURANCE	EMPLOYEE HEALTH INSURANCE		1,192.31	
	<a href="#">100-1350-6020-0000</a>	HEALTH INSURANCE	EMPLOYEE HEALTH INSURANCE		3,099.95	
	<a href="#">100-1550-6020-0000</a>	HEALTH INSURANCE	EMPLOYEE HEALTH INSURANCE		655.77	
	<a href="#">100-2000-6020-0000</a>	HEALTH INSURANCE	EMPLOYEE HEALTH INSURANCE		3,576.82	
	<a href="#">100-2050-6020-0000</a>	HEALTH INSURANCE	EMPLOYEE HEALTH INSURANCE		48,406.58	
	<a href="#">100-2090-6020-0000</a>	HEALTH INSURANCE	EMPLOYEE HEALTH INSURANCE		10,849.80	
	<a href="#">100-2150-6020-0000</a>	HEALTH INSURANCE	EMPLOYEE HEALTH INSURANCE		7,153.64	
	<a href="#">100-3100-6020-0000</a>	HEALTH INSURANCE	EMPLOYEE HEALTH INSURANCE		10,134.36	
	<a href="#">100-3250-6020-0000</a>	HEALTH INSURANCE	EMPLOYEE HEALTH INSURANCE		7,153.64	
	<a href="#">100-6050-6020-0000</a>	HEALTH INSURANCE	EMPLOYEE HEALTH INSURANCE		15,738.11	
	<a href="#">700-4050-6020-0000</a>	HEALTH INSURANCE	EMPLOYEE HEALTH INSURANCE		1,788.41	
	<a href="#">750-7000-6020-0000</a>	HEALTH INSURANCE	EMPLOYEE HEALTH INSURANCE		3,636.49	
	<a href="#">750-7100-6020-0000</a>	HEALTH INSURANCE	EMPLOYEE HEALTH INSURANCE		1,192.31	
	<a href="#">750-7300-6020-0000</a>	HEALTH INSURANCE	EMPLOYEE HEALTH INSURANCE		5,484.52	
	<a href="#">750-7400-6020-0000</a>	HEALTH INSURANCE	EMPLOYEE HEALTH INSURANCE		1,311.54	
	<a href="#">750-7600-6020-0000</a>	HEALTH INSURANCE	EMPLOYEE HEALTH INSURANCE		1,311.54	
	<a href="#">750-7700-6020-0000</a>	HEALTH INSURANCE	EMPLOYEE HEALTH INSURANCE		2,384.57	
	<a href="#">750-7800-6020-0000</a>	HEALTH INSURANCE	EMPLOYEE HEALTH INSURANCE		1,192.31	
	<a href="#">750-7900-6020-0000</a>	HEALTH INSURANCE	EMPLOYEE HEALTH INSURANCE		1,192.32	
1831	LAURA'S CUSTOM EMBROIDERY	11/26/2019	Regular	0.00	2,672.20	104066
Payable #	Payable Type	Post Date	Payable Description	Discount Amount	Payable Amount	
	Account Number	Account Name	Item Description	Distribution Amount		
<a href="#">2650</a>	Invoice	11/26/2019	EMBROIDERY FOR UNIFORMS	0.00	2,672.20	
	<a href="#">100-2150-7065-0000</a>	UNIFORMS	EMBROIDERY FOR UNIFORMS		43.01	
	<a href="#">100-6050-7065-0000</a>	UNIFORMS	EMBROIDERY FOR UNIFORMS		1,740.02	
	<a href="#">700-4050-7065-0000</a>	UNIFORMS	EMBROIDERY FOR UNIFORMS		215.50	
	<a href="#">750-7200-7065-0000</a>	UNIFORMS	EMBROIDERY FOR UNIFORMS		673.67	
3848	LAURIE MILLER	11/26/2019	Regular	0.00	681.44	104067
Payable #	Payable Type	Post Date	Payable Description	Discount Amount	Payable Amount	
	Account Number	Account Name	Item Description	Distribution Amount		
<a href="#">11/26/19</a>	Invoice	11/26/2019	REIMBURSEMENT FOR EMPLOYEE HOLIDAY	0.00	681.44	
	<a href="#">100-1200-7066-0000</a>	TRAVEL, EDUCATION, TRA	REIMBURSEMENT FOR EMPLOY		681.44	
3379	LAW OFFICES BURKE, WILLIAMS & SORENSEN,	11/26/2019	Regular	0.00	2,403.00	104068
Payable #	Payable Type	Post Date	Payable Description	Discount Amount	Payable Amount	
	Account Number	Account Name	Item Description	Distribution Amount		
<a href="#">247353</a>	Invoice	11/26/2019	LEGAL SERVICES	0.00	2,403.00	
	<a href="#">120-9663-7300-0000</a>	CONTRACTUAL SERVICES	LEGAL SERVICES		2,403.00	
1850	LESLIE'S SWIMMING POOL SUPPLIES	11/26/2019	Regular	0.00	281.50	104069
Payable #	Payable Type	Post Date	Payable Description	Discount Amount	Payable Amount	
	Account Number	Account Name	Item Description	Distribution Amount		
<a href="#">01062-02-000858</a>	Invoice	11/26/2019	EQUIPMENT MAINTENANCE	0.00	281.50	
	<a href="#">100-6150-7090-0000</a>	EQUIPMENT SUPPLIES/M	EQUIPMENT MAINTENANCE		281.50	
1967	MORONGO BAND OF MISSION INDIANS	11/26/2019	Regular	0.00	16,816.08	104070



Check Report

Date Range: 11/22/2019 - 11/22/2019

2.

Vendor Number Payable #	Vendor Name Payable Type Account Number	Payment Date Post Date	Payment Type Payable Description Account Name Item Description	Discount Amount	Payment Amount Payable Amount Distribution Amount	Num
<a href="#">2019-079</a>	Invoice <a href="#">710-0000-7068-0000</a> <a href="#">710-0000-7068-0000</a>	11/26/2019	MONITORING SERVICES CONTRACTUAL SERVICE CONTRACTUAL SERVICE	0.00	9,073.03 4,536.52 4,536.51	
<a href="#">2019-081</a>	Invoice <a href="#">710-0000-7068-0000</a> <a href="#">710-0000-7068-0000</a>	11/26/2019	MONITORING SERVICES CONTRACTUAL SERVICE CONTRACTUAL SERVICE	0.00	3,037.62 1,518.81 1,518.81	
<a href="#">2019-082</a>	Invoice <a href="#">710-0000-7068-0000</a> <a href="#">710-0000-7068-0000</a>	11/26/2019	MONITORING SERVICES CONTRACTUAL SERVICE CONTRACTUAL SERVICE	0.00	3,117.43 1,558.72 1,558.71	
<a href="#">2019-083</a>	Invoice <a href="#">710-0000-7068-0000</a> <a href="#">710-0000-7068-0000</a>	11/26/2019	MONITORING SERVICES CONTRACTUAL SERVICE CONTRACTUAL SERVICE	0.00	1,588.00 794.00 794.00	
2007	NV5, INC Payable Type Account Number	11/26/2019	Regular Payable Description Account Name Item Description	0.00	21,420.00	104071 ✓
<a href="#">139413</a>	Invoice <a href="#">100-3100-7067-0000</a>	11/26/2019	INSPECTION SERVICES INSPECTIONS	0.00	514.50 514.50	
<a href="#">139415</a>	Invoice <a href="#">100-3100-7067-0000</a>	11/26/2019	INSPECTION SERVICES INSPECTIONS	0.00	934.50 934.50	
<a href="#">139416</a>	Invoice <a href="#">100-3100-7067-0000</a>	11/26/2019	INSPECTION SERVICES INSPECTIONS	0.00	582.75 582.75	
<a href="#">139418</a>	Invoice <a href="#">100-3100-7067-0000</a>	11/26/2019	INSPECTION SERVICES INSPECTIONS	0.00	147.00 147.00	
<a href="#">139420</a>	Invoice <a href="#">100-3100-7067-0000</a>	11/26/2019	INSPECTION SERVICES INSPECTIONS	0.00	750.75 750.75	
<a href="#">139422</a>	Invoice <a href="#">100-3100-7067-0000</a>	11/26/2019	INSPECTION SERVICES INSPECTIONS	0.00	430.50 430.50	
<a href="#">139423</a>	Invoice <a href="#">100-3100-7067-0000</a>	11/26/2019	INSPECTION SERVICES INSPECTIONS	0.00	147.00 147.00	
<a href="#">139425</a>	Invoice <a href="#">100-3100-7067-0000</a>	11/26/2019	INSPECTION SERVICES INSPECTIONS	0.00	493.50 493.50	
<a href="#">139426</a>	Invoice <a href="#">100-3100-7067-0000</a>	11/26/2019	INSPECTION SERVICES INSPECTIONS	0.00	336.00 336.00	
<a href="#">139428</a>	Invoice <a href="#">100-3100-7067-0000</a>	11/26/2019	INSPECTION SERVICES INSPECTIONS	0.00	1,858.50 1,858.50	
<a href="#">139430</a>	Invoice <a href="#">100-3100-7067-0000</a>	11/26/2019	INSPECTION SERVICES INSPECTIONS	0.00	735.00 735.00	
<a href="#">139431</a>	Invoice <a href="#">100-3100-7067-0000</a>	11/26/2019	INSPECTION SERVICES INSPECTIONS	0.00	147.00 147.00	
<a href="#">139432</a>	Invoice <a href="#">100-3100-7067-0000</a>	11/26/2019	INSPECTION SERVICES INSPECTIONS	0.00	141.75 141.75	
<a href="#">139433</a>	Invoice <a href="#">100-3100-7067-0000</a>	11/26/2019	INSPECTION SERVICES INSPECTIONS	0.00	1,176.00 1,176.00	
<a href="#">139434</a>	Invoice <a href="#">100-3100-7067-0000</a>	11/26/2019	INSPECTION SERVICES INSPECTIONS	0.00	1,984.50 1,984.50	
<a href="#">139435</a>	Invoice <a href="#">100-3100-7067-0000</a>	11/26/2019	INSPECTION SERVICES INSPECTIONS	0.00	120.75 120.75	
<a href="#">139436</a>	Invoice <a href="#">100-3100-7067-0000</a>	11/26/2019	INSPECTION SERVICES INSPECTIONS	0.00	2,583.00 2,583.00	
<a href="#">139437</a>	Invoice <a href="#">100-3100-7067-0000</a>	11/26/2019	INSPECTION SERVICES INSPECTIONS	0.00	105.00 105.00	

Check Report

Date Range: 11/22/2019 - 11/22/2019

2.

Vendor Number	Vendor Name	Payment Date	Payment Type	Discount Amount	Payment Amount	Num
<u>139438</u>	Invoice <u>100-3100-7067-0000</u>	11/26/2019	INSPECTION SERVICES INSPECTIONS	0.00	325.50	
<u>139439</u>	Invoice <u>100-3100-7067-0000</u>	11/26/2019	INSPECTION SERVICES INSPECTIONS	0.00	1,953.00	
<u>139440</u>	Invoice <u>100-3100-7067-0000</u>	11/26/2019	INSPECTION SERVICES INSPECTIONS	0.00	262.50	
<u>139441</u>	Invoice <u>100-3100-7067-0000</u>	11/26/2019	INSPECTION SERVICES INSPECTIONS	0.00	299.25	
<u>139442</u>	Invoice <u>100-3100-7067-0000</u>	11/26/2019	INSPECTION SERVICES INSPECTIONS	0.00	441.00	
<u>139443</u>	Invoice <u>100-3100-7067-0000</u>	11/26/2019	INSPECTION SERVICES INSPECTIONS	0.00	246.75	
<u>139444</u>	Invoice <u>100-3100-7067-0000</u>	11/26/2019	INSPECTION SERVICES INSPECTIONS	0.00	283.50	
<u>139445</u>	Invoice <u>100-3100-7067-0000</u>	11/26/2019	INSPECTION SERVICES INSPECTIONS	0.00	2,399.25	
<u>139446</u>	Invoice <u>100-3100-7067-0000</u>	11/26/2019	INSPECTION SERVICES INSPECTIONS	0.00	147.00	
<u>139447</u>	Invoice <u>100-3100-7067-0000</u>	11/26/2019	INSPECTION SERVICES INSPECTIONS	0.00	304.50	
<u>139448</u>	Invoice <u>100-3100-7067-0000</u>	11/26/2019	INSPECTION SERVICES INSPECTIONS	0.00	1,281.00	
<u>139449</u>	Invoice <u>100-3100-7067-0000</u>	11/26/2019	INSPECTION SERVICES INSPECTIONS	0.00	141.75	
<u>139450</u>	Invoice <u>100-3100-7067-0000</u>	11/26/2019	INSPECTION SERVICES INSPECTIONS	0.00	147.00	
	**Void**	11/26/2019	Regular	0.00	0.00	104072
	**Void**	11/26/2019	Regular	0.00	0.00	104073
2026	PACIFIC ALARM SERVICE	11/26/2019	Regular	0.00	59.85	104074
<b>Payable #</b>	<b>Payable Type</b>	<b>Post Date</b>	<b>Payable Description</b>	<b>Discount Amount</b>	<b>Payable Amount</b>	
	<b>Account Number</b>		<b>Account Name</b>		<b>Distribution Amount</b>	
<u>R 150818</u>	Invoice	11/26/2019	SECURITY SERVICES	0.00	59.85	
	<u>700-4050-7087-0000</u>		SECURITY SERVICES		59.85	
2072	POLYDYNE, INC.	11/26/2019	Regular	0.00	11,491.14	104075
<b>Payable #</b>	<b>Payable Type</b>	<b>Post Date</b>	<b>Payable Description</b>	<b>Discount Amount</b>	<b>Payable Amount</b>	
	<b>Account Number</b>		<b>Account Name</b>		<b>Distribution Amount</b>	
<u>1398996</u>	Invoice	11/26/2019	CHEMICALS & SUPPLIES	0.00	5,745.57	
	<u>700-4050-7070-0000</u>		SPECIAL DEPT SUPPLIES		5,745.57	
<u>1403543</u>	Invoice	11/26/2019	CHEMICALS & SUPPLIES	0.00	5,745.57	
	<u>700-4050-7070-0000</u>		SPECIAL DEPT SUPPLIES		5,745.57	
2074	PRE-PAID LEGAL SERVICES INC	11/26/2019	Regular	0.00	737.25	104076 ✓
<b>Payable #</b>	<b>Payable Type</b>	<b>Post Date</b>	<b>Payable Description</b>	<b>Discount Amount</b>	<b>Payable Amount</b>	
	<b>Account Number</b>		<b>Account Name</b>		<b>Distribution Amount</b>	
<u>PD 10/22/19-11/</u>	Invoice	11/26/2019	OPTIONAL EMPLOYEE SERVICES	0.00	737.25	
	<u>100-0000-2045-0000</u>		PRE PAID LEGAL		737.25	
2098	QUILL CORPORATON	11/26/2019	Regular	0.00	59.33	104077
<b>Payable #</b>	<b>Payable Type</b>	<b>Post Date</b>	<b>Payable Description</b>	<b>Discount Amount</b>	<b>Payable Amount</b>	
	<b>Account Number</b>		<b>Account Name</b>		<b>Distribution Amount</b>	
<u>2146953</u>	Invoice	11/26/2019	DEPT SUPPLIES	0.00	59.33	
	<u>100-1550-7070-0000</u>		SPECIAL DEPT SUPPLIES		59.33	
3421	REDLANDS-YUCAIPA RENTALS, INC.	11/26/2019	Regular	0.00	330.00	104078



Vendor Number	Vendor Name	Payment Date	Payment Type	Discount Amount	Payment Amount	Num
Payable #	Payable Type	Post Date	Payable Description	Discount Amount	Payable Amount	
	Account Number	Account Name	Item Description	Distribution Amount		
352020	Invoice	11/26/2019	EQUIPMENT RENTAL	0.00	330.00	
	<a href="#">100-6050-7075-018X</a>		EQUIP LEASING/RENTAL (I		330.00	
3844	ROBERT RODRIGUEZ	11/26/2019	Regular	0.00	174.76	104079
Payable #	Payable Type	Post Date	Payable Description	Discount Amount	Payable Amount	
	Account Number	Account Name	Item Description	Distribution Amount		
<a href="#">06-011082-03</a>	Invoice	11/26/2019	REIMBURSE CREDIT ON UTILITY ACCT	0.00	174.76	
	<a href="#">100-0000-1400-0000</a>		A/R - UTILITIES		174.76	
3846	SAM HUMPHRIES	11/26/2019	Regular	0.00	100.60	104080
Payable #	Payable Type	Post Date	Payable Description	Discount Amount	Payable Amount	
	Account Number	Account Name	Item Description	Distribution Amount		
<a href="#">04-018717-02</a>	Invoice	11/26/2019	REIMBURSE CREDIT ON UTILITY ACCOUNT	0.00	100.60	
	<a href="#">100-0000-1400-0000</a>		A/R - UTILITIES		100.60	
3845	SAMANTHA GONZALEZ	11/26/2019	Regular	0.00	40.00	104081
Payable #	Payable Type	Post Date	Payable Description	Discount Amount	Payable Amount	
	Account Number	Account Name	Item Description	Distribution Amount		
<a href="#">RCT 943686</a>	Invoice	11/26/2019	DEPOSIT REFUND	0.00	40.00	
	<a href="#">100-0000-4590-0000</a>		BUILDING RENTAL		40.00	
2309	SOUTH COAST AQMD	11/26/2019	Regular	0.00	557.42	104082 ✓
Payable #	Payable Type	Post Date	Payable Description	Discount Amount	Payable Amount	
	Account Number	Account Name	Item Description	Distribution Amount		
<a href="#">3547919</a>	Invoice	11/26/2019	ANNUAL RENEWAL & EMISSIONS FEES	0.00	421.02	
	<a href="#">700-4050-7022-007A</a>		LICENSE, PERMITS, FEES		421.02	
<a href="#">3551016</a>	Invoice	11/26/2019	ANNUAL RENEWAL & EMISSIONS FEES	0.00	136.40	
	<a href="#">700-4050-7022-007A</a>		LICENSE, PERMITS, FEES		136.40	
2311	SOUTHERN CALIFORNIA EDISON	11/26/2019	Regular	0.00	67,371.92	104083
Payable #	Payable Type	Post Date	Payable Description	Discount Amount	Payable Amount	
	Account Number	Account Name	Item Description	Distribution Amount		
<a href="#">11/26/19</a>	Invoice	11/26/2019	ELECTRIC UTILITY	0.00	67,371.92	
	<a href="#">100-3250-7010-0000</a>		UTILITIES		352.17	
	<a href="#">100-3250-7010-008A</a>		UTILITIES (IA 8A)		26.54	
	<a href="#">100-3250-7010-014A</a>		UTILITIES (IA 14A)		90.27	
	<a href="#">100-3250-7010-014X</a>		UTILITIES (IA 14)		48.51	
	<a href="#">100-3250-7010-018X</a>		UTILITIES (IA 18)		65.94	
	<a href="#">100-3250-7010-019C</a>		UTILITIES (IA 19C)		27.33	
	<a href="#">100-3250-7010-06A1</a>		UTILITIES (IA 6A1)		47.99	
	<a href="#">100-6000-7010-6025</a>		UTILITIES - CITY HALL		1,340.64	
	<a href="#">100-6000-7010-6031</a>		UTILITIES - CITY HALL BLD		802.06	
	<a href="#">100-6000-7010-6032</a>		UTILITIES - CITY HALL BLD		802.06	
	<a href="#">100-6000-7010-6040</a>		UTILITIES - POLICE DEPT		2,425.51	
	<a href="#">100-6000-7010-6041</a>		UTILITIES - POLICE ANNEX		290.84	
	<a href="#">100-6000-7010-6055</a>		UTILITIES - FIRE STATION		375.73	
	<a href="#">100-6050-7010-0000</a>		UTILITIES		1,423.68	
	<a href="#">100-6050-7010-002X</a>		UTILITIES IA 2		95.16	
	<a href="#">100-6050-7010-008C</a>		UTILITIES IA 8C		12.99	
	<a href="#">100-6050-7010-008E</a>		UTILITIES IA 8E		10.68	
	<a href="#">100-6050-7010-014X</a>		UTILITIES IA 14		11.63	
	<a href="#">100-6050-7010-06A1</a>		UTILITIES IA 6A1		20.34	
	<a href="#">700-4050-7010-0000</a>		UTILITIES		58,827.84	
	<a href="#">750-7300-7010-0000</a>		UTILITIES		274.01	
2405	THE COUNSELING TEAM	11/26/2019	Regular	0.00	300.00	104084 ✓



Check Report

Date Range: 11/22/2019 - 11/22/2019

2.

Vendor Number	Vendor Name	Payment Date	Payment Type	Discount Amount	Payment Amount	Num
Payable #	Payable Type	Post Date	Payable Description	Discount Amount	Payable Amount	
Account Number	Account Name	Item Description	Distribution Amount			
<u>400962076</u>	Invoice	11/26/2019	PUMP REPAIR AT THE WWTP	0.00	1,176.67	
	<u>700-4050-7075-0000</u>		EQUIPMENT LEASING/RE PUMP RENTAL		1,176.67	
3675	ZENITH AMERICAN SOLUTIONS	11/26/2019	Regular	0.00	6.14	104091
Payable #	Payable Type	Post Date	Payable Description	Discount Amount	Payable Amount	
Account Number	Account Name	Item Description	Distribution Amount			
<u>PD 11/08/19-11/</u>	Invoice	11/26/2019	OPTIONAL EMPLOYEE INSURANCE	0.00	6.14	
	<u>100-0000-2085-0000</u>		ZENITH WITHHOLDING OPTIONAL EMPLOYEE INSURAN		6.14	

Bank Code APBNK Summary

Payment Type	Payable Count	Payment Count	Discount	Payment
Regular Checks	103	54	0.00	609,443.28
Manual Checks	0	0	0.00	0.00
Voided Checks	0	2	0.00	0.00
Bank Drafts	0	0	0.00	0.00
EFT's	20	6	0.00	5,811,730.79
	<b>123</b>	<b>62</b>	<b>0.00</b>	<b>6,421,174.07</b>

### All Bank Codes Check Summary

Payment Type	Payable Count	Payment Count	Discount	Payment
Regular Checks	103	54	0.00	609,443.28
Manual Checks	0	0	0.00	0.00
Voided Checks	0	2	0.00	0.00
Bank Drafts	0	0	0.00	0.00
EFT's	20	6	0.00	5,811,730.79
	<b>123</b>	<b>62</b>	<b>0.00</b>	<b>6,421,174.07</b>

### Fund Summary

Fund	Name	Period	Amount
999	POOLED CASH	11/2019	6,421,174.07
			<u>6,421,174.07</u>



WARRANTS TO BE RATIFIED

Thursday, December 05, 2019

<b>Printed Checks</b>	104092-104162	\$	598,202.14	FY 19/20
<b>ACH</b>	233	\$	184,288.28	
	A/P Total	\$	<u>782,490.42</u>	
<b>Bank Drafts</b>	CalPERS	\$	47,008.87	743 Classic 10/18/19-10/31/19
		\$	45,873.85	742 Classic 10/18/19-10/31/19
		\$	12,915.49	27308 PEPRA 10/18/19-10/31/19
		\$	8,721.09	25763 PEPRA 10/18/19-10/31/19
		\$	49.12	27308 PEPRA 11/25/19
	MG Trust	\$	23,594.67	457 Paydate 11/22/19
		\$	23,514.38	457 Paydate 11/08/19
		\$	4,950.98	401-A Paydate 11/08/19
		\$	4,896.51	401-A Paydate 11/22/19
		\$	1,065.81	FICA Paydate 11/22/19
		\$	1,056.94	FICA Paydate 11/08/19
	Cardpointe	\$	5,212.13	Credit Card Fees
	Authnet Gateway	\$	266.80	Dec-19

I DO HEREBY CERTIFY THIS WARRANT LIST HAS BEEN COMPILED AND PREPARED TO MEET THE DAILY OPERATIONS FOR THE FISCAL YEAR JULY 1, 2019 - JUNE 30, 2020

SIGNATURE:   
 TITLE: CITY TREASURER

SIGNATURE:   
 TITLE: ADMINISTRATIVE SERVICES DIRECTOR



Vendor Number	Vendor Name	Payment Date	Payment Type	Discount Amount	Payment Amount	Number
3503	CITIZENS BUSINESS BANK	11/27/2019	EFT	0.00	184,288.28	233
<b>Payable #</b>	<b>Payable Type</b>	<b>Post Date</b>	<b>Payable Description</b>	<b>Discount Amount</b>	<b>Payable Amount</b>	
<u>APPLICATION 11</u>	Invoice	11/27/2019	W LYLES RETENTION ESCROW	0.00	184,288.28	
	<u>710-0000-8030-0000</u>		CAPITAL IMPROVEMENT		184,288.28	
			W LYLES RETENTION ESCROW			
1042	ALL PURPOSE RENTALS	12/05/2019	Regular	0.00	136.40	104092
<b>Payable #</b>	<b>Payable Type</b>	<b>Post Date</b>	<b>Payable Description</b>	<b>Discount Amount</b>	<b>Payable Amount</b>	
<u>39529</u>	Invoice	12/04/2019	EQUIPMENT RENTAL	0.00	136.40	
	<u>100-6050-7075-5999</u>		EQUIPMENT LEASING/RE		136.40	
			EQUIPMENT RENTAL			
1050	AMAZON CAPITAL SERVICES	12/05/2019	Regular	0.00	1,169.07	104093
<b>Payable #</b>	<b>Payable Type</b>	<b>Post Date</b>	<b>Payable Description</b>	<b>Discount Amount</b>	<b>Payable Amount</b>	
<u>1JGY-7JDL-9PNL</u>	Invoice	12/04/2019	DEPT SUPPLIES	0.00	853.10	
	<u>100-2050-7070-0000</u>		SPECIAL DEPT SUPPLIES		853.10	
			DEPT SUPPLIES			
<u>1R6W-97QP-LPPC</u>	Invoice	12/04/2019	OFFICE SUPPLIES	0.00	30.43	
	<u>100-1225-7025-0000</u>		OFFICE SUPPLIES		30.43	
			OFFICE SUPPLIES			
<u>1T6T-RJGP-LHVK</u>	Invoice	12/04/2019	OFFICE SUPPLIES	0.00	285.54	
	<u>100-2050-7025-0000</u>		OFFICE SUPPLIES		285.54	
			OFFICE SUPPLIES			
1053	AMERICAN FORENSIC NURSES	12/05/2019	Regular	0.00	532.00	104094
<b>Payable #</b>	<b>Payable Type</b>	<b>Post Date</b>	<b>Payable Description</b>	<b>Discount Amount</b>	<b>Payable Amount</b>	
<u>72746</u>	Invoice	12/05/2019	American Forensic Nurses - Services	0.00	476.00	
	<u>100-2050-7068-0000</u>		CONTRACTUAL SERVICES		476.00	
			American Forensic Nurses - Serv			
<u>72783</u>	Invoice	12/04/2019	American Forensic Nurses - Services	0.00	56.00	
	<u>100-2050-7068-0000</u>		CONTRACTUAL SERVICES		56.00	
			American Forensic Nurses - Serv			
3851	APRIL WARNER	12/05/2019	Regular	0.00	400.00	104095
<b>Payable #</b>	<b>Payable Type</b>	<b>Post Date</b>	<b>Payable Description</b>	<b>Discount Amount</b>	<b>Payable Amount</b>	
<u>11/29/19</u>	Invoice	12/04/2019	DONATION FROM PINK PATCH PROJECT	0.00	400.00	
	<u>240-2360-7096-0000</u>		PINK PATCHES PROGRAM		400.00	
			DONATION FROM PINK PATCH P			
1080	ARAMARK	12/05/2019	Regular	0.00	89.77	104096
<b>Payable #</b>	<b>Payable Type</b>	<b>Post Date</b>	<b>Payable Description</b>	<b>Discount Amount</b>	<b>Payable Amount</b>	
<u>1626780</u>	Invoice	12/04/2019	OFFICE SUPPLIES	0.00	89.77	
	<u>100-2000-7025-0000</u>		OFFICE SUPPLIES		4.49	
	<u>100-2050-7025-0000</u>		OFFICE SUPPLIES		85.28	
			OFFICE SUPPLIES			
3661	ARROWHEAD GROUP INC	12/05/2019	Regular	0.00	417.50	104097
<b>Payable #</b>	<b>Payable Type</b>	<b>Post Date</b>	<b>Payable Description</b>	<b>Discount Amount</b>	<b>Payable Amount</b>	
<u>21016</u>	Invoice	12/05/2019	Backflow Testing and Repair	0.00	337.50	
	<u>100-6050-7068-5999</u>		CONTRACT SVC - ALL PAR		337.50	
			Backflow Testing and Repair			
<u>21046</u>	Invoice	12/05/2019	Backflow Testing and Repair	0.00	80.00	
	<u>100-6050-7068-5999</u>		CONTRACT SVC - ALL PAR		80.00	
			Backflow Testing and Repair			
1100	AUTOZONE	12/05/2019	Regular	0.00	95.13	104098



Check Report

Date Range: 11/27/2019 - 12/01/2019

2.

Vendor Number Payable #	Vendor Name Payable Type Account Number	Post Date	Payment Date Account Name	Payment Type Payable Description Item Description	Discount Amount Discount Amount	Payment Amount Payable Amount Distribution Amount	NU
2882106034	Invoice 100-2050-7037-0000	12/04/2019	12/04/2019	VEHICLE MAINTENANCE VEHICLE MAINTENANCE VEHICLE MAINTENANCE	0.00	33.39 33.39	
2882106310	Invoice 100-2050-7037-0000	12/04/2019	12/04/2019	VEHICLE MAINTENANCE VEHICLE MAINTENANCE VEHICLE MAINTENANCE	0.00	44.17 44.17	
2882108324	Credit Memo 100-2050-7037-0000	12/04/2019	12/04/2019	VEHICLE MAINTENANCE VEHICLE MAINTENANCE VEHICLE MAINTENANCE	0.00	-44.17 -44.17	
2882109502	Invoice 100-2050-7037-0000	12/04/2019	12/04/2019	VEHICLE MAINTENANCE VEHICLE MAINTENANCE VEHICLE MAINTENANCE	0.00	61.74 61.74	

1147 Payable #	BEAUMONT CHERRY VALLEY WATER DIST. Payable Type Account Number	Post Date	12/05/2019 Account Name	Regular Payable Description Item Description	Discount Amount	70,018.16 Payable Amount Distribution Amount	104099
12/23/19	Invoice 100-3250-7010-0000	12/04/2019	12/04/2019	WATER UTILITIES UTILITIES WATER UTILITIES	0.00	70,018.16 9,156.90	
	100-3250-7010-007A			UTILITIES (IA 7A) WATER UTILITIES		2,002.20	
	100-3250-7010-007B			UTILITIES (IA 7B) WATER UTILITIES		616.79	
	100-3250-7010-008A			UTILITIES (IA 8A) WATER UTILITIES		675.76	
	100-3250-7010-008B			UTILITIES (IA 8B) WATER UTILITIES		428.47	
	100-3250-7010-010A			UTILITIES (IA 10) WATER UTILITIES		1,102.03	
	100-3250-7010-012A			UTILITIES (IA 12) WATER UTILITIES		300.68	
	100-3250-7010-014B			UTILITIES (IA 14B) WATER UTILITIES		1,724.39	
	100-3250-7010-014X			UTILITIES (IA 14) WATER UTILITIES		6,493.10	
	100-3250-7010-015X			UTILITIES (IA 15) WATER UTILITIES		1,130.80	
	100-3250-7010-016X			UTILITIES (IA 16) WATER UTILITIES		2,649.77	
	100-3250-7010-018X			UTILITIES (IA 18) WATER UTILITIES		337.29	
	100-3250-7010-019A			UTILITIES (IA 19A) WATER UTILITIES		1,342.21	
	100-3250-7010-019C			UTILITIES (IA 19C) WATER UTILITIES		210.65	
	100-3250-7010-06A1			UTILITIES (IA 6A1) WATER UTILITIES		5,064.16	
	100-6000-7010-6045			UTILITIES - COMMUNITY WATER UTILITIES		817.90	
	100-6050-7010-0000			UTILITIES WATER UTILITIES		2,233.10	
	100-6050-7010-003X			UTILITIES IA 3 WATER UTILITIES		4,874.58	
	100-6050-7010-007A			UTILITIES IA 7A WATER UTILITIES		669.17	
	100-6050-7010-008A			UTILITIES IA 8A (SUNDAN) WATER UTILITIES		4,771.97	
	100-6050-7010-008C			UTILITIES IA 8C WATER UTILITIES		25.86	
	100-6050-7010-008D			UTILITIES IA 8D WATER UTILITIES		150.78	
	100-6050-7010-008E			UTILITIES IA 8E WATER UTILITIES		75.39	
	100-6050-7010-014A			UTILITIES IA 14A (OAK VA) WATER UTILITIES		558.18	
	100-6050-7010-014B			UTILITIES IA 14B WATER UTILITIES		1,784.63	
	100-6050-7010-017A			UTILITIES IA 17A (TOURN) WATER UTILITIES		1,444.76	
	100-6050-7010-018X			UTILITIES IA 18 WATER UTILITIES		25.86	
	100-6050-7010-019C			UTILITIES IA 19C WATER UTILITIES		538.20	
	100-6050-7010-020X			UTILITIES IA 20 WATER UTILITIES		465.97	
	100-6050-7010-06A1			UTILITIES IA 6A1 WATER UTILITIES		635.54	
	100-6050-7010-5050			UTILITIES, PARK (DEFORG) WATER UTILITIES		643.95	
	100-6050-7010-5200			UTILITIES, PARK (PALMER) WATER UTILITIES		12.35	
	100-6050-7010-5250			UTILITIES, PARK (RANGAL) WATER UTILITIES		605.15	
	100-6050-7010-5350			UTILITIES, PARK (SHADO) WATER UTILITIES		283.88	
	100-6050-7010-5400			UTILITIES, PARK (SPORTS) WATER UTILITIES		6,216.47	
	100-6050-7010-5450			UTILITIES, PARK (STETSON) WATER UTILITIES		4,486.68	
	100-6050-7010-5500			UTILITIES, PARK (STEWAR) WATER UTILITIES		2,909.19	
	100-6050-7010-5600			UTILITIES, PARK (TREVINO) WATER UTILITIES		75.39	
	100-6050-7010-5650			UTILITIES, PARK (VETERA) WATER UTILITIES		111.29	
	100-6050-7010-5700			UTILITIES, PARK (WILD FL) WATER UTILITIES		1,161.79	
	700-4050-7010-0000			UTILITIES WATER UTILITIES		1,188.08	
	700-4050-7010-019C			UTILITIES (IA 19C) WATER UTILITIES		16.85	

1127	BEAUMONT DO IT BEST HOME CENTER	12/05/2019	Regular		0.00	38.06	104100
------	---------------------------------	------------	---------	--	------	-------	--------

Check Report

Date Range: 11/27/2019 - 12/05/2019

2.

Vendor Number	Vendor Name	Payment Date	Payment Type	Discount Amount	Payment Amount	Num
Payable #	Payable Type	Post Date	Payable Description	Discount Amount	Payable Amount	
	Account Number	Account Name	Item Description	Distribution Amount		
479320	Invoice 100-2050-7037-0000	12/04/2019	VEHICLE MAINTENANCE VEHICLE MAINTENANCE	0.00	36.83	
479415	Credit Memo 100-3250-7070-0000	12/04/2019	DEPT SUPPLIES SPECIAL DEPT SUPPLIES	0.00	-5.13	
479418	Credit Memo 100-3250-7070-0000	12/04/2019	DEPT SUPPLIES SPECIAL DEPT SUPPLIES	0.00	-10.26	
480310	Invoice 500-0000-8030-0000	12/04/2019	BUILDING MIANTENANCE INFRASTRUCTURE IMPRO	0.00	16.62	
1155	BEST BUY Payable Type	12/05/2019	Regular	0.00	1,826.04	104101
12/04/19	Invoice 100-2050-7070-0000	12/04/2019	DEPT SUPPLIES SPECIAL DEPT SUPPLIES	0.00	1,826.04	
2861	BROWNELLS, INC Payable Type	12/05/2019	Regular	0.00	1,195.76	104102
18275901.00	Invoice 100-2050-7070-0000	12/04/2019	DEPT SUPPLIES SPECIAL DEPT SUPPLIES	0.00	285.73	
18275908.00	Invoice 100-2050-7070-0000	12/04/2019	DEPT SUPPLIES SPECIAL DEPT SUPPLIES	0.00	910.03	
1204	CALIFORNIA INLAND EMPIRE COUNCIL Payable Type	12/05/2019	Regular	0.00	643.50	104103
11/13/19	Invoice 240-2310-7096-0000	12/04/2019	YOUTH REGISTRATION NOV/DEC 2019 PROGRAM COSTS - EXPLO	0.00	643.50	
1250	CHAMBERS GROUP, INC Payable Type	12/05/2019	Regular	0.00	1,050.00	104104
33811	Invoice 500-0000-7068-0000	12/04/2019	GENERAL PLAN EIR WORK CONTRACTUAL SERVICE	0.00	1,050.00	
1273	CHRISTOPHER CREWS Payable Type	12/05/2019	Regular	0.00	3,147.71	104105
11/20/19	Invoice 100-2050-7070-0000	12/04/2019	DEPT SUPPLIES SPECIAL DEPT SUPPLIES	0.00	210.90	
12/01/19-12/05/19	Invoice 100-2050-7066-0000	12/04/2019	EMPLOYEE TRAVEL REIMBURSEMENT TRAVEL, EDUCATION, TRA	0.00	2,059.31	
26334	Invoice 240-2360-7096-0000	12/04/2019	REIMBURSEMENT FOR EVENT SUPPLIES PINK PATCHES PROGRAM	0.00	877.50	
1370	DASH MEDICAL GLOVES Payable Type	12/05/2019	Regular	0.00	176.39	104106
INV1174103	Invoice 100-2050-7070-0000	12/04/2019	DEPT SUPPLIES SPECIAL DEPT SUPPLIES	0.00	176.39	
1414	DIAMOND HILLS AUTO GROUP Payable Type	12/05/2019	Regular	0.00	88.09	104107
657128	Invoice 100-2050-7037-0000	12/04/2019	VEHICLE MAINTENANCE VEHICLE MAINTENANCE	0.00	88.09	

Check Report

Date Range: 11/27/2019 - 12/31/2019

2.

Vendor Number	Vendor Name	Payment Date	Payment Type	Discount Amount	Payment Amount	Num
1422	DICK'S ALL AUTO REPAIR, INC	12/05/2019	Regular	0.00	258.75	104108
Payable #	Payable Type	Post Date	Payable Description	Discount Amount	Payable Amount	
Account Number	Account Name	Item Description	Distribution Amount			
<u>22677</u>	Invoice	12/04/2019	VEHICLE MAINTENANCE	0.00	51.75	
	<u>100-2050-7037-0000</u>		VEHICLE MAINTENANCE		51.75	
<u>22678</u>	Invoice	12/04/2019	VEHICLE MAINTENANCE	0.00	51.75	
	<u>100-2050-7037-0000</u>		VEHICLE MAINTENANCE		51.75	
<u>22682</u>	Invoice	12/04/2019	VEHICLE MAINTENANCE	0.00	51.75	
	<u>100-2050-7037-0000</u>		VEHICLE MAINTENANCE		51.75	
<u>22683</u>	Invoice	12/04/2019	VEHICLE MAINTENANCE	0.00	51.75	
	<u>100-2050-7037-0000</u>		VEHICLE MAINTENANCE		51.75	
<u>22725</u>	Invoice	12/04/2019	VEHICLE MAINTENANCE	0.00	51.75	
	<u>100-2050-7037-0000</u>		VEHICLE MAINTENANCE		51.75	
1424	DIRECTV	12/05/2019	Regular	0.00	113.24	104109
Payable #	Payable Type	Post Date	Payable Description	Discount Amount	Payable Amount	
Account Number	Account Name	Item Description	Distribution Amount			
<u>36913369251</u>	Invoice	12/04/2019	BUILDING UTILITY	0.00	113.24	
	<u>100-6000-7010-6040</u>		UTILITIES - POLICE DEPT		113.24	
1435	DOOLEY ENTERPRISES, INC.	12/05/2019	Regular	0.00	4,373.03	104110
Payable #	Payable Type	Post Date	Payable Description	Discount Amount	Payable Amount	
Account Number	Account Name	Item Description	Distribution Amount			
<u>012290</u>	Invoice	12/05/2019	Ammunition Purchase (various rounds/qu	0.00	4,373.03	
	<u>100-2050-7070-0000</u>		SPECIAL DEPT SUPPLIES		528.03	
	<u>100-2050-7070-0000</u>		SPECIAL DEPT SUPPLIES		618.00	
	<u>100-2050-7070-0000</u>		SPECIAL DEPT SUPPLIES		128.50	
	<u>100-2050-7070-0000</u>		SPECIAL DEPT SUPPLIES		1,146.00	
	<u>100-2050-7070-0000</u>		SPECIAL DEPT SUPPLIES		985.00	
	<u>100-2050-7070-0000</u>		SPECIAL DEPT SUPPLIES		193.00	
	<u>100-2050-7070-0000</u>		SPECIAL DEPT SUPPLIES		522.00	
	<u>100-2050-7070-0000</u>		SPECIAL DEPT SUPPLIES		252.50	
2605	ELIZABETH VEGA	12/05/2019	Regular	0.00	540.12	104111
Payable #	Payable Type	Post Date	Payable Description	Discount Amount	Payable Amount	
Account Number	Account Name	Item Description	Distribution Amount			
<u>06-009197-08</u>	Invoice	12/04/2019	REIMBURSE CREDIT ON ACCOUNT	0.00	540.12	
	<u>100-0000-1400-0000</u>		A/R - UTILITIES		540.12	
1479	ENTENMANN-ROVIN CO	12/05/2019	Regular	0.00	241.50	104112
Payable #	Payable Type	Post Date	Payable Description	Discount Amount	Payable Amount	
Account Number	Account Name	Item Description	Distribution Amount			
<u>0146525-IN</u>	Invoice	12/04/2019	EMPLOYEE UNIFORM	0.00	241.50	
	<u>100-2050-7065-0000</u>		UNIFORMS		241.50	
1509	FEDEX	12/05/2019	Regular	0.00	218.44	104113
Payable #	Payable Type	Post Date	Payable Description	Discount Amount	Payable Amount	
Account Number	Account Name	Item Description	Distribution Amount			
<u>6-847-07690</u>	Invoice	12/04/2019	OFFICE SUPPLIES	0.00	218.44	
	<u>100-2050-7025-0000</u>		OFFICE SUPPLIES		218.44	
1518	FLYERS ENERGY	12/05/2019	Regular	0.00	6,442.81	104114
Payable #	Payable Type	Post Date	Payable Description	Discount Amount	Payable Amount	
Account Number	Account Name	Item Description	Distribution Amount			
<u>CFS-2087377</u>	Invoice	12/04/2019	FUEL EXPENSE	0.00	2,139.31	
	<u>750-7100-7050-0000</u>		FUEL		372.42	
	<u>750-7400-7050-0000</u>		FUEL		1,318.14	
	<u>750-7600-7050-0000</u>		FUEL		3.33	
	<u>750-7700-7050-0000</u>		FUEL		445.42	

Check Report

Date Range: 11/27/2019 - 019

2.

Vendor Number	Vendor Name	Payment Date	Payment Type	Discount Amount	Payment Amount	Num
<u>CFS-2089767</u>	Invoice	12/04/2019	FUEL EXPENSE	0.00	2,213.85	
	<u>750-7100-7050-0000</u>	FUEL	FUEL EXPENSE		137.20	
	<u>750-7400-7050-0000</u>	FUEL	FUEL EXPENSE		1,656.27	
	<u>750-7600-7050-0000</u>	FUEL	FUEL EXPENSE		3.33	
	<u>750-7700-7050-0000</u>	FUEL	FUEL EXPENSE		319.61	
	<u>750-8000-7050-0000</u>	FUEL	FUEL EXPENSE		97.44	
<u>CFS-2117085</u>	Invoice	12/04/2019	FUEL EXPENSE	0.00	2,089.65	
	<u>750-7400-7050-0000</u>	FUEL	FUEL EXPENSE		1,604.63	
	<u>750-7600-7050-0000</u>	FUEL	FUEL EXPENSE		3.33	
	<u>750-7700-7050-0000</u>	FUEL	FUEL EXPENSE		481.69	
3782	FRANCISCO CISNEROS	12/05/2019	Regular	0.00	1,500.00	104115
<b>Payable #</b>	<b>Payable Type</b>	<b>Post Date</b>	<b>Payable Description</b>	<b>Discount Amount</b>	<b>Payable Amount</b>	
<u>138</u>	Invoice	12/04/2019	PROFESSIONAL SERVICES	0.00	1,500.00	
	<u>500-0000-8990-0000</u>	CAPITAL OUTLAY	PROFESSIONAL SERVICES		1,500.00	
1533	FRONTIER COMMUNICATIONS	12/05/2019	Regular	0.00	2,425.91	104116
<b>Payable #</b>	<b>Payable Type</b>	<b>Post Date</b>	<b>Payable Description</b>	<b>Discount Amount</b>	<b>Payable Amount</b>	
<u>209-042-1999-06</u>	Invoice	12/04/2019	PHONE UTILITY	0.00	279.06	
	<u>100-1230-7015-6040</u>	TELEPHONE (POLICE DPT)	PHONE UTILITY		279.06	
<u>213-181-1343-03</u>	Invoice	12/04/2019	PHONE UTILITY	0.00	69.47	
	<u>700-4050-7015-0000</u>	TELEPHONE	PHONE UTILITY		69.47	
<u>951-769-8500-01</u>	Invoice	12/04/2019	PHONE UTILITY	0.00	1,340.48	
	<u>100-1230-7015-6040</u>	TELEPHONE (POLICE DPT)	PHONE UTILITY		1,340.48	
<u>951-769-8520-01</u>	Invoice	12/04/2019	PHONE UTILITY	0.00	271.03	
	<u>100-1230-7015-6025</u>	TELEPHONE (CITY HALL)	PHONE UTILITY		271.03	
<u>951-769-8530-06</u>	Invoice	12/04/2019	PHONE UTILITY	0.00	236.36	
	<u>750-7000-7015-0000</u>	TELEPHONE	PHONE UTILITY		236.36	
<u>951-769-8538-06</u>	Invoice	12/04/2019	PHONE UTILITY	0.00	77.92	
	<u>100-1230-7015-6048</u>	TELEPHONE (POOL)	PHONE UTILITY		77.92	
<u>951-769-8539-04</u>	Invoice	12/04/2019	PHONE UTILITY	0.00	151.59	
	<u>100-1230-7015-6045</u>	TELEPHONE (COMM CTR)	PHONE UTILITY		151.59	
3572	HECTOR ALVARADO	12/05/2019	Regular	0.00	1,830.00	104117
<b>Payable #</b>	<b>Payable Type</b>	<b>Post Date</b>	<b>Payable Description</b>	<b>Discount Amount</b>	<b>Payable Amount</b>	
<u>1095</u>	Invoice	12/05/2019	Bus Washing Service	0.00	1,830.00	
	<u>750-7100-7068-0000</u>	CONTRACTUAL SERVICES	VEHICLE MAINTENANCE		200.00	
	<u>750-7400-7068-0000</u>	CONTRACTUAL EXPENSES	VEHICLE MAINTENANCE		490.00	
	<u>750-7600-7068-0000</u>	CONTRACTUAL SERVICES	VEHICLE MAINTENANCE		300.00	
	<u>750-7700-7068-0000</u>	CONTRACTUAL SERVICES	VEHICLE MAINTENANCE		300.00	
	<u>750-7800-7068-0000</u>	CONTRACTUAL SERVICES	VEHICLE MAINTENANCE		100.00	
	<u>750-7900-7068-0000</u>	CONTRACTUAL SERVICES	VEHICLE MAINTENANCE		100.00	
	<u>750-8000-7068-0000</u>	CONTRACTUAL SERVICES	VEHICLE MAINTENANCE		100.00	
	<u>750-8100-7068-0000</u>	CONTRACTUAL SERVICES	VEHICLE MAINTENANCE		160.00	
	<u>750-8200-7068-0000</u>	CONTRACTUAL SERVICES	VEHICLE MAINTENANCE		80.00	
1632	HOME DEPOT/CREDIT SERVICES	12/05/2019	Regular	0.00	2,783.76	104118
<b>Payable #</b>	<b>Payable Type</b>	<b>Post Date</b>	<b>Payable Description</b>	<b>Discount Amount</b>	<b>Payable Amount</b>	
<u>1015429</u>	Invoice	12/05/2019	DEPARTMENT SUPPLIES - STREETS	0.00	161.58	
	<u>100-3250-7070-0000</u>	SPECIAL DEPT SUPPLIES	DEPARTMENT SUPPLIES - STREE		161.58	
<u>1021297</u>	Invoice	12/05/2019	DEPARTMENT SUPPLIES - SEWER	0.00	54.84	
	<u>700-4050-7070-0000</u>	SPECIAL DEPT SUPPLIES	DEPARTMENT SUPPLIES - SEWE		54.84	
<u>1021579</u>	Invoice	12/04/2019	BUILDING MAINTENANCE	0.00	32.40	

Check Report

Date Range: 11/27/2019 - 12/01/2019

2.

Vendor Number	Vendor Name	Payment Date	Payment Type	Discount Amount	Payment Amount	Num
	<u>100-6000-7085-6025</u>	BLDG MAINT - CITY HALL	BUILDING MAINTENANCE		32.40	
<u>10811</u>	Invoice	12/04/2019	BUILDING MAINTENANCE	0.00	268.48	
	<u>500-0000-8030-0000</u>	INFRASTRUCTURE IMPRO	BUILDING MAINTENANCE		268.48	
<u>1371476</u>	Invoice	12/04/2019	DEPT SUPPLIES	0.00	69.97	
	<u>100-6050-7070-5400</u>	SPEC DEPT EXP - SPORTS	DEPT SUPPLIES		69.97	
<u>15483</u>	Invoice	12/05/2019	DEPARTMENT SUPPLIES - STREETS	0.00	7.38	
	<u>100-3250-7070-0000</u>	SPECIAL DEPT SUPPLIES	DEPARTMENT SUPPLIES - STREE		7.38	
<u>1903922</u>	Invoice	12/04/2019	EVENT SUPPLIES	0.00	50.00	
	<u>100-1200-7041-0000</u>	EVENTS	EVENT SUPPLIES		50.00	
<u>1903931</u>	Credit Memo	12/04/2019	EVENT SUPPLIES RETURN	0.00	-14.45	
	<u>100-1200-7041-0000</u>	EVENTS	EVENT SUPPLIES RETURN		-14.45	
<u>2015333</u>	Invoice	12/05/2019	DEPARTMENT SUPPLIES - STREETS	0.00	43.07	
	<u>100-3250-7070-0000</u>	SPECIAL DEPT SUPPLIES	DEPARTMENT SUPPLIES - STREE		43.07	
<u>2621912</u>	Invoice	12/04/2019	BUILDING MAINTENANCE	0.00	39.61	
	<u>100-6000-7085-6025</u>	BLDG MAINT - CITY HALL	BUILDING MAINTENANCE		39.61	
<u>3010568</u>	Invoice	12/04/2019	BUILDING MAINTENANCE	0.00	101.09	
	<u>100-6000-7085-6025</u>	BLDG MAINT - CITY HALL	BUILDING MAINTENANCE		101.09	
<u>3014408</u>	Invoice	12/04/2019	BUILDING MAINTENANCE	0.00	47.89	
	<u>100-6000-7085-6025</u>	BLDG MAINT - CITY HALL	BUILDING MAINTENANCE		47.89	
<u>4032731</u>	Invoice	12/04/2019	DEPT SUPPLIES	0.00	75.14	
	<u>100-6050-7070-5400</u>	SPEC DEPT EXP - SPORTS	DEPT SUPPLIES		75.14	
<u>4032732</u>	Invoice	12/04/2019	BUILDING MAINTENANCE	0.00	26.33	
	<u>100-6000-7085-6055</u>	BLDG MAINT- FIRE STATIO	BUILDING MAINTENANCE		26.33	
<u>5010372</u>	Invoice	12/05/2019	DEPARTMENT SUPPLIES - SEWER	0.00	214.42	
	<u>700-4050-7070-0000</u>	SPECIAL DEPT SUPPLIES	DEPARTMENT SUPPLIES - SEWE		214.42	
<u>5030648</u>	Invoice	12/04/2019	EQUIPMENT MAINTENANCE	0.00	114.87	
	<u>100-6000-7090-6045</u>	EQUIPMENT SUPPLIES/M	EQUIPMENT MAINTENANCE		24.57	
	<u>100-6050-7070-0000</u>	SPECIAL DEPT SUPPLIES	EQUIPMENT MAINTENANCE		90.30	
<u>5130531</u>	Invoice	12/04/2019	DEPT SUPPLIES	0.00	221.86	
	<u>100-6050-7070-0000</u>	SPECIAL DEPT SUPPLIES	DEPT SUPPLIES		221.86	
<u>7011083</u>	Invoice	12/04/2019	DEPT SUPPLIES	0.00	64.43	
	<u>100-6050-7070-5550</u>	SPEC DEPT EXP - SUNNY	DEPT SUPPLIES		64.43	
<u>7033416</u>	Invoice	12/04/2019	DEPT SUPPLIES	0.00	19.83	
	<u>100-6050-7070-5550</u>	SPEC DEPT EXP - SUNNY	DEPT SUPPLIES		19.83	
<u>7324496</u>	Invoice	12/04/2019	DEPT SUPPLIES	0.00	480.45	
	<u>100-6050-7070-0000</u>	SPECIAL DEPT SUPPLIES	DEPT SUPPLIES		480.45	
<u>7523014</u>	Invoice	12/04/2019	BUILDING MAINTENANCE	0.00	38.01	
	<u>750-7000-7085-0000</u>	BUILDING SUPPLIES/MAI	BUILDING MAINTENANCE		38.01	
<u>7622337</u>	Invoice	12/04/2019	BUILDING MAINTENANCE	0.00	45.93	
	<u>100-6000-7085-6025</u>	BLDG MAINT - CITY HALL	BUILDING MAINTENANCE		45.93	
<u>9014754</u>	Invoice	12/04/2019	EQUIPMENT MAINTENANCE	0.00	322.75	
	<u>100-6050-7090-0000</u>	EQUIPMENT SUPPLIES/M	EQUIPMENT MAINTENANCE		322.75	
<u>9014755</u>	Invoice	12/04/2019	DEPT SUPPLIES	0.00	38.45	
	<u>100-6050-7070-5400</u>	SPEC DEPT EXP - SPORTS	DEPT SUPPLIES		38.45	
<u>9021367</u>	Invoice	12/04/2019	BUILDING MAINTENANCE	0.00	259.43	
	<u>500-0000-8030-0000</u>	INFRASTRUCTURE IMPRO	BUILDING MAINTENANCE		259.43	
	**Void**	12/05/2019	Regular	0.00	0.00	104119
3852	JAMES ROWELL	12/05/2019	Regular	0.00	281.00	104120



Check Report

Date Range: 11/27/2019 - 12/31/2019

2.

Vendor Number	Vendor Name	Payment Date	Payment Type	Discount Amount	Payment Amount	Num
Payable #	Payable Type	Post Date	Payable Description	Discount Amount	Payable Amount	
	Account Number	Account Name	Item Description	Distribution Amount		
11/13/19	Invoice	12/04/2019	REIMBURSEMENT FOR MEMBERSHIP REN	0.00	281.00	
	700-4050-7030-0000	DUES & SUBSCRIPTIONS	REIMBURSEMENT FOR MEMBE		281.00	
3232	JDV PROCESS EQUIPMENT CORP	12/05/2019	Regular	0.00	2,500.00	104121
4519	Invoice	12/04/2019	EQUIPMENT	0.00	2,500.00	
	710-0000-8030-0000	CAPITAL IMPROVEMENT	EQUIPMENT		2,500.00	
1805	KONICA MINOLTA BUSINESS SOLUTIONS	12/05/2019	Regular	0.00	123.92	104122
34400700	Invoice	12/04/2019	EQUIPMENT RENTAL	0.00	123.92	
	100-1230-7075-0000	EQUIPMENT LEASING/RE	EQUIPMENT RENTAL		123.92	
3271	KS STATEBANK	12/05/2019	Regular	0.00	35,492.31	104123
3353429 03/01/1	Invoice	12/05/2019	VACTOR TRUCK & PATCH TRUCK	0.00	11,830.77	
	100-3250-8060-0000	VEHICLES	VACTOR TRUCK & PATCH TRUCK		3,194.30	
	710-0000-8060-0000	VEHICLES	VACTOR TRUCK & PATCH TRUCK		8,636.47	
3353429 11/01/1	Invoice	12/05/2019	VACTOR TRUCK & PATCH TRUCK	0.00	11,830.77	
	100-3250-8060-0000	VEHICLES	VACTOR TRUCK & PATCH TRUCK		3,194.30	
	710-0000-8060-0000	VEHICLES	VACTOR TRUCK & PATCH TRUCK		8,636.47	
3353429 12/01/1	Invoice	12/05/2019	VACTOR TRUCK & PATCH TRUCK	0.00	11,830.77	
	100-3250-8060-0000	VEHICLES	VACTOR TRUCK & PATCH TRUCK		3,194.30	
	710-0000-8060-0000	VEHICLES	VACTOR TRUCK & PATCH TRUCK		8,636.47	
3834	LEASE SERVICING CENTER, INC	12/05/2019	Regular	0.00	250.00	104124
12/04/19	Invoice	12/04/2019	INITIAL PROCESSING FEE	0.00	250.00	
	100-2050-7053-0000	PERMITS, FEES AND LICE	INITIAL PROCESSING FEE		250.00	
1853	LEWIS BRISBOIS BISGAARD & SMITH LLP	12/05/2019	Regular	0.00	225.00	104125
2493776	Invoice	12/04/2019	LEGAL SERVICES	0.00	225.00	
	120-9663-7300-0000	CONTRACTUAL SERVICES	LEGAL SERVICES		225.00	
3506	LISA LEACH	12/05/2019	Regular	0.00	295.00	104126
10/29/19	Invoice	12/04/2019	TRAINING REIMBURSEMENT	0.00	295.00	
	100-1225-7066-0000	TRAVEL, EDUCATION, TRA	TRAINING REIMBURSEMENT		295.00	
3853	LOMA LINDA UNIVERSITY MEDICAL CENTER	12/05/2019	Regular	0.00	500.00	104127
12/04/19	Invoice	12/04/2019	DONATION FROM PINK PATCH PROJECT	0.00	500.00	
	240-2360-7096-0000	PINK PATCHES PROGRAM	DONATION FROM PINK PATCH P		500.00	
1901	MANNING & KASS, ELLROD, RAMIREZ	12/05/2019	Regular	0.00	20,653.23	104128
653399	Invoice	12/04/2019	LEGAL SERVICES	0.00	20,653.23	
	120-9663-7300-0000	CONTRACTUAL SERVICES	LEGAL SERVICES		20,653.23	



Check Report

Date Range: 11/27/2019 - 12/31/2019

2.

Vendor Number	Vendor Name	Payment Date	Payment Type	Discount Amount	Payment Amount	Num
1904	MARCEDES CASHMER	12/05/2019	Regular	0.00	14.01	104129
Payable #	Payable Type	Post Date	Payable Description	Discount Amount	Payable Amount	
Account Number	Account Name	Item Description	Distribution Amount			
<u>11/20/19</u>	Invoice	12/04/2019	REIMBURSEMENT FOR DEPT SUPPLIES	0.00	14.01	
	<u>100-2050-7070-0000</u>		SPECIAL DEPT SUPPLIES		14.01	
			REIMBURSEMENT FOR DEPT SU			
3530	MOBILE HOMES ACCEPTANCE CORP	12/05/2019	Regular	0.00	425.61	104130
Payable #	Payable Type	Post Date	Payable Description	Discount Amount	Payable Amount	
Account Number	Account Name	Item Description	Distribution Amount			
<u>218059</u>	Invoice	12/05/2019	MONTHLY RENTAL FEE FOR WWTP OFFICE	0.00	425.61	
	<u>700-4050-7075-0000</u>		EQUIPMENT LEASING/RE		425.61	
			MONTHLY RENTAL FEE FOR WW			
1967	MORONGO BAND OF MISSION INDIANS	12/05/2019	Regular	0.00	5,138.72	104131
Payable #	Payable Type	Post Date	Payable Description	Discount Amount	Payable Amount	
Account Number	Account Name	Item Description	Distribution Amount			
<u>2019-085</u>	Invoice	12/04/2019	MONITORING SERVICES	0.00	2,341.98	
	<u>710-0000-7068-0000</u>		CONTRACTUAL SERVICE		1,170.99	
	<u>710-0000-7068-0000</u>		CONTRACTUAL SERVICE		1,170.99	
<u>2019-087</u>	Invoice	12/04/2019	MONITORING SERVICES	0.00	2,796.74	
	<u>710-0000-7068-0000</u>		CONTRACTUAL SERVICE		1,398.37	
	<u>710-0000-7068-0000</u>		CONTRACTUAL SERVICE		1,398.37	
3186	MWH CONSTRUCTORS INC	12/05/2019	Regular	0.00	290,090.19	104132
Payable #	Payable Type	Post Date	Payable Description	Discount Amount	Payable Amount	
Account Number	Account Name	Item Description	Distribution Amount			
<u>19-30504503-08</u>	Invoice	12/05/2019	CONSTRUCTION MANAGEMENT FOR WW	0.00	101,917.51	
	<u>710-0000-7068-0000</u>		CONTRACTUAL SERVICE		101,917.51	
<u>19-30505107-08</u>	Invoice	12/05/2019	BRINE LINE INSTALLATION CONSTRUCTIO	0.00	188,172.68	
	<u>710-0000-8030-0000</u>		CAPITAL IMPROVEMENT		188,172.68	
			BRINE LINE INSTALLATION CONS			
1984	NAPA AUTO PARTS	12/05/2019	Regular	0.00	372.64	104133
Payable #	Payable Type	Post Date	Payable Description	Discount Amount	Payable Amount	
Account Number	Account Name	Item Description	Distribution Amount			
<u>106296</u>	Invoice	12/04/2019	VEHICLE MAINTENANCE	0.00	44.17	
	<u>100-2050-7037-0000</u>		VEHICLE MAINTENANCE		44.17	
			VEHICLE MAINTENANCE			
<u>107129</u>	Invoice	12/04/2019	VEHICLE MAINTENANCE	0.00	218.82	
	<u>100-2050-7037-0000</u>		VEHICLE MAINTENANCE		218.82	
			VEHICLE MAINTENANCE			
<u>107443</u>	Invoice	12/04/2019	VEHICLE MAINTENANCE	0.00	31.23	
	<u>100-2050-7037-0000</u>		VEHICLE MAINTENANCE		31.23	
			VEHICLE MAINTENANCE			
<u>107445</u>	Invoice	12/04/2019	VEHICLE MAINTENANCE	0.00	5.92	
	<u>100-2050-7037-0000</u>		VEHICLE MAINTENANCE		5.92	
			VEHICLE MAINTENANCE			
<u>107504</u>	Invoice	12/04/2019	VEHICLE MAINTENANCE	0.00	3.22	
	<u>100-2050-7037-0000</u>		VEHICLE MAINTENANCE		3.22	
			VEHICLE MAINTENANCE			
<u>107505</u>	Invoice	12/04/2019	VEHICLE MAINTENANCE	0.00	29.76	
	<u>100-2050-7037-0000</u>		VEHICLE MAINTENANCE		29.76	
			VEHICLE MAINTENANCE			
<u>107694</u>	Invoice	12/04/2019	VEHICLE MAINTENANCE	0.00	1.85	
	<u>100-2050-7037-0000</u>		VEHICLE MAINTENANCE		1.85	
			VEHICLE MAINTENANCE			
<u>107798</u>	Invoice	12/04/2019	VEHICLE MAINTENANCE	0.00	37.67	
	<u>100-2050-7037-0000</u>		VEHICLE MAINTENANCE		37.67	
			VEHICLE MAINTENANCE			
2009	O'REILLY AUTO PARTS	12/05/2019	Regular	0.00	1,037.34	104134
Payable #	Payable Type	Post Date	Payable Description	Discount Amount	Payable Amount	
Account Number	Account Name	Item Description	Distribution Amount			
<u>2678-222796</u>	Invoice	12/04/2019	VEHICLE MAINTENANCE	0.00	72.94	
	<u>100-2050-7037-0000</u>		VEHICLE MAINTENANCE		72.94	
			VEHICLE MAINTENANCE			
<u>2678-222998</u>	Invoice	12/04/2019	VEHICLE MAINTENANCE	0.00	181.07	
	<u>100-2050-7037-0000</u>		VEHICLE MAINTENANCE		181.07	
			VEHICLE MAINTENANCE			

Check Report

Date Range: 11/27/2019 - 12/31/2019

2.

Vendor Number	Vendor Name	Payment Date	Payment Type	Discount Amount	Payment Amount	Num
<u>2678-223036</u>	Credit Memo <u>100-2050-7037-0000</u>	12/04/2019	VEHICLE MAINTENANCE	0.00	-181.07	
			VEHICLE MAINTENANCE		-181.07	
<u>2678-223944</u>	Invoice <u>100-2050-7037-0000</u>	12/04/2019	VEHICLE MAINTENANCE	0.00	34.26	
			VEHICLE MAINTENANCE		34.26	
<u>2678-223959</u>	Invoice <u>100-2050-7037-0000</u>	12/04/2019	VEHICLE MAINTENANCE	0.00	185.93	
			VEHICLE MAINTENANCE		185.93	
<u>2678-224221</u>	Invoice <u>100-2050-7037-0000</u>	12/04/2019	VEHICLE MAINTENANCE	0.00	105.13	
			VEHICLE MAINTENANCE		105.13	
<u>2678-224352</u>	Credit Memo <u>100-2050-7037-0000</u>	12/04/2019	RETURNED PARTS	0.00	-78.19	
			VEHICLE MAINTENANCE		-78.19	
<u>2678-225241</u>	Invoice <u>100-2100-7037-0000</u>	12/04/2019	VEHICLE MAINTENANCE	0.00	362.14	
			VEHICLE MAINTENANCE		362.14	
<u>2678-225703</u>	Invoice <u>100-2050-7037-0000</u>	12/04/2019	VEHICLE MAINTENANCE	0.00	156.54	
			VEHICLE MAINTENANCE		156.54	
<u>2678-225780</u>	Credit Memo <u>100-2050-7037-0000</u>	12/04/2019	VEHICLE MAINTENANCE	0.00	-11.85	
			VEHICLE MAINTENANCE		-11.85	
<u>2678-226648</u>	Invoice <u>100-2050-7037-0000</u>	12/04/2019	VEHICLE MAINTENANCE	0.00	181.07	
			VEHICLE MAINTENANCE		181.07	
<u>2678-226761</u>	Invoice <u>100-2050-7037-0000</u>	12/04/2019	VEHICLE MAINTENANCE	0.00	23.69	
			VEHICLE MAINTENANCE		23.69	
<u>2678-226772</u>	Credit Memo <u>100-2050-7037-0000</u>	12/04/2019	VEHICLE MAINTENANCE	0.00	-18.00	
			VEHICLE MAINTENANCE		-18.00	
<u>2678-226775</u>	Invoice <u>100-2050-7037-0000</u>	12/04/2019	VEHICLE MAINTENANCE	0.00	23.68	
			VEHICLE MAINTENANCE		23.68	
<u>2678-226779</u>	Credit Memo <u>100-2050-7037-0000</u>	12/04/2019	VEHICLE MAINTENANCE	0.00	-19.38	
			VEHICLE MAINTENANCE		-19.38	
<u>2678-226780</u>	Invoice <u>100-2050-7037-0000</u>	12/04/2019	VEHICLE MAINTENANCE	0.00	19.38	
			VEHICLE MAINTENANCE		19.38	
	**Void**	12/05/2019	Regular	0.00	0.00	104135
2076	PRINTING & PROMOTION PLUS, INC.	12/05/2019	Regular	0.00	1,461.24	104136
<b>Payable #</b>	<b>Payable Type</b>	<b>Post Date</b>	<b>Payable Description</b>	<b>Discount Amount</b>	<b>Payable Amount</b>	
	<b>Account Number</b>		<b>Account Name</b>		<b>Distribution Amount</b>	
<u>75248</u>	Invoice <u>100-1200-7025-0000</u>	12/04/2019	OFFICE SUPPLIES	0.00	901.06	
			OFFICE SUPPLIES		901.06	
<u>75283</u>	Invoice <u>100-2000-7025-0000</u> <u>100-2050-7025-0000</u>	12/04/2019	OFFICE SUPPLIES	0.00	560.18	
			OFFICE SUPPLIES		28.01	
			OFFICE SUPPLIES		532.17	
3652	PRUDENTIAL OVERALL SUPPLY	12/05/2019	Regular	0.00	774.81	104137
<b>Payable #</b>	<b>Payable Type</b>	<b>Post Date</b>	<b>Payable Description</b>	<b>Discount Amount</b>	<b>Payable Amount</b>	
	<b>Account Number</b>		<b>Account Name</b>		<b>Distribution Amount</b>	
<u>22855405</u>	Invoice <u>750-7100-7065-0000</u> <u>750-7400-7065-0000</u> <u>750-7600-7065-0000</u> <u>750-7700-7065-0000</u> <u>750-7800-7065-0000</u> <u>750-7900-7065-0000</u>	12/05/2019	Prudential Uniforms	0.00	123.55	
			UNIFORMS		13.70	
			UNIFORMS		25.81	
			UNIFORMS		27.13	
			UNIFORMS		19.86	
			UNIFORMS		19.83	
			UNIFORMS		17.22	
<u>22855407</u>	Invoice <u>750-7300-7065-0000</u>	12/05/2019	Prudential Uniforms	0.00	54.20	
			UNIFORMS		54.20	
<u>22855409</u>	Invoice <u>100-6050-7065-0000</u>	12/05/2019	Prudential Uniforms	0.00	92.40	
			UNIFORMS		92.40	
<u>22873796</u>	Invoice <u>750-7100-7065-0000</u>	12/05/2019	Prudential Uniforms	0.00	127.57	
			UNIFORMS		14.28	

Check Report

Date Range: 11/27/2019 - 12/31/2019

2.

Vendor Number	Vendor Name	Payment Date	Payment Type	Discount Amount	Payment Amount	NU
	<u>750-7400-7065-0000</u>	UNIFORMS	UNIFORM MAINTENANCE	29.36		
	<u>750-7600-7065-0000</u>	UNIFORMS	UNIFORM MAINTENANCE	27.71		
	<u>750-7700-7065-0000</u>	UNIFORMS	UNIFORM MAINTENANCE	17.46		
	<u>750-7800-7065-0000</u>	UNIFORMS	UNIFORM MAINTENANCE	20.44		
	<u>750-7900-7065-0000</u>	UNIFORMS	UNIFORM MAINTENANCE	18.32		
<u>22884622</u>	Invoice	12/05/2019	Prudential Uniforms	0.00	140.07	
	<u>750-7100-7065-0000</u>	UNIFORMS	UNIFORM MAINTENANCE	17.36		
	<u>750-7400-7065-0000</u>	UNIFORMS	UNIFORM MAINTENANCE	34.29		
	<u>750-7600-7065-0000</u>	UNIFORMS	UNIFORM MAINTENANCE	28.92		
	<u>750-7700-7065-0000</u>	UNIFORMS	UNIFORM MAINTENANCE	20.54		
	<u>750-7800-7065-0000</u>	UNIFORMS	UNIFORM MAINTENANCE	20.54		
	<u>750-7900-7065-0000</u>	UNIFORMS	UNIFORM MAINTENANCE	18.42		
<u>22884624</u>	Invoice	12/05/2019	Prudential Uniforms	0.00	54.20	
	<u>750-7300-7065-0000</u>	UNIFORMS	UNIFORM MAINTENANCE	54.20		
<u>22888320</u>	Invoice	12/05/2019	Prudential Uniforms	0.00	60.94	
	<u>700-4050-7065-0000</u>	UNIFORMS	UNIFORM MAINTENANCE	60.94		
<u>22895540</u>	Invoice	12/05/2019	Prudential Uniforms	0.00	60.94	
	<u>700-4050-7065-0000</u>	UNIFORMS	UNIFORM MAINTENANCE	60.94		
<u>22899073</u>	Invoice	12/05/2019	Prudential Uniforms	0.00	60.94	
	<u>700-4050-7065-0000</u>	UNIFORMS	UNIFORM MAINTENANCE	60.94		
2126	REDLANDS FORD	12/05/2019	Regular	0.00	24,322.54	104138
<b>Payable #</b>	<b>Payable Type</b>	<b>Post Date</b>	<b>Payable Description</b>	<b>Discount Amount</b>	<b>Payable Amount</b>	
	<b>Account Number</b>		<b>Account Name</b>		<b>Distribution Amount</b>	
<u>1FMCU0F66LUA3</u>	Invoice	12/04/2019	2020 FORD ESCAPE	0.00	24,322.54	
	<u>100-2150-8060-0000</u>		VEHICLES		24,322.54	
2988	RHONDA KEYSER	12/05/2019	Regular	0.00	1,525.84	104139
<b>Payable #</b>	<b>Payable Type</b>	<b>Post Date</b>	<b>Payable Description</b>	<b>Discount Amount</b>	<b>Payable Amount</b>	
	<b>Account Number</b>		<b>Account Name</b>		<b>Distribution Amount</b>	
<u>12/06/19</u>	Invoice	12/04/2019	PAYROLL CORRECTION	0.00	1,525.84	
	<u>100-0000-2105-0000</u>		PAYROLL SUSPENSE		1,525.84	
3681	RIVERSIDE COUNTY DEPARTMENT OF WASTE R	12/05/2019	Regular	0.00	14.00	104140
<b>Payable #</b>	<b>Payable Type</b>	<b>Post Date</b>	<b>Payable Description</b>	<b>Discount Amount</b>	<b>Payable Amount</b>	
	<b>Account Number</b>		<b>Account Name</b>		<b>Distribution Amount</b>	
<u>7128543</u>	Invoice	12/04/2019	DEPT SUPPLIES	0.00	14.00	
	<u>100-2050-7070-0000</u>		SPECIAL DEPT SUPPLIES		14.00	
2180	RIVERSIDE COUNTY TREASURER	12/05/2019	Regular	0.00	283.64	104141
<b>Payable #</b>	<b>Payable Type</b>	<b>Post Date</b>	<b>Payable Description</b>	<b>Discount Amount</b>	<b>Payable Amount</b>	
	<b>Account Number</b>		<b>Account Name</b>		<b>Distribution Amount</b>	
<u>PIN 009618494</u>	Invoice	12/04/2019	2020 PROPERTY TAX FOR VFW	0.00	283.64	
	<u>100-6000-7022-6050</u>		LICENSE, PERMTIS, FEES -		283.64	
2234	SAN BERNARDINO COUNTY SHERIFF'S DEPART	12/05/2019	Regular	0.00	4,500.00	104142
<b>Payable #</b>	<b>Payable Type</b>	<b>Post Date</b>	<b>Payable Description</b>	<b>Discount Amount</b>	<b>Payable Amount</b>	
	<b>Account Number</b>		<b>Account Name</b>		<b>Distribution Amount</b>	
<u>RNG-19-028</u>	Invoice	12/05/2019	San Bernardino Trimester PSP Training	0.00	4,500.00	
	<u>100-2050-7066-0000</u>		TRAVEL, EDUCATION, TRA		4,500.00	
2267	SGP DESIGN AND PRINT	12/05/2019	Regular	0.00	306.62	104143
<b>Payable #</b>	<b>Payable Type</b>	<b>Post Date</b>	<b>Payable Description</b>	<b>Discount Amount</b>	<b>Payable Amount</b>	
	<b>Account Number</b>		<b>Account Name</b>		<b>Distribution Amount</b>	
<u>11577</u>	Invoice	12/04/2019	OFFICE SUPPLIES	0.00	71.42	
	<u>100-1050-7025-0000</u>		OFFICE SUPPLIES		23.80	
	<u>100-1225-7025-0000</u>		OFFICE SUPPLIES		23.82	
	<u>100-1350-7025-0000</u>		OFFICE SUPPLIES		23.80	
<u>11590</u>	Invoice	12/04/2019	OFFICE SUPPLIES	0.00	235.20	

Vendor Number	Vendor Name	Payment Date	Payment Type	Discount Amount	Payment Amount	Num
	<a href="#">100-2000-7025-0000</a>	OFFICE SUPPLIES	OFFICE SUPPLIES		21.38	
	<a href="#">100-2050-7025-0000</a>	OFFICE SUPPLIES	OFFICE SUPPLIES		213.82	
3498	SKM ENGINEERING LLC	12/05/2019	Regular	0.00	642.50	104144
<b>Payable #</b>	<b>Payable Type</b>	<b>Post Date</b>	<b>Payable Description</b>	<b>Discount Amount</b>	<b>Payable Amount</b>	
	<b>Account Number</b>		<b>Account Name</b>	<b>Item Description</b>	<b>Distribution Amount</b>	
<a href="#">18398</a>	Invoice	12/05/2019	SCADA SERVICES	0.00	642.50	
	<a href="#">700-4050-7068-0000</a>	CONTRACTUAL SERVICES	SCADA SERVICES		642.50	
2311	SOUTHERN CALIFORNIA EDISON	12/05/2019	Regular	0.00	9,259.89	104145
<b>Payable #</b>	<b>Payable Type</b>	<b>Post Date</b>	<b>Payable Description</b>	<b>Discount Amount</b>	<b>Payable Amount</b>	
	<b>Account Number</b>		<b>Account Name</b>	<b>Item Description</b>	<b>Distribution Amount</b>	
<a href="#">12/04/19</a>	Invoice	12/04/2019	ELECTRIC UTILITY	0.00	9,259.89	
	<a href="#">100-3250-7010-0000</a>	UTILITIES	ELECTRIC UTILITY		2,078.96	
	<a href="#">100-3250-7010-004X</a>	UTILITIES (IA 4)	ELECTRIC UTILITY		183.72	
	<a href="#">100-3250-7010-006B</a>	UTILITIES (IA 6B)	ELECTRIC UTILITY		218.55	
	<a href="#">100-3250-7010-007A</a>	UTILITIES (IA 7A)	ELECTRIC UTILITY		134.57	
	<a href="#">100-3250-7010-007D</a>	UTILITIES (IA 7D)	ELECTRIC UTILITY		111.52	
	<a href="#">100-3250-7010-008A</a>	UTILITIES (IA 8A)	ELECTRIC UTILITY		413.24	
	<a href="#">100-3250-7010-008B</a>	UTILITIES (IA 8B)	ELECTRIC UTILITY		70.47	
	<a href="#">100-3250-7010-008C</a>	UTILITIES (IA 8C)	ELECTRIC UTILITY		191.94	
	<a href="#">100-3250-7010-008D</a>	UTILITIES (IA 8D)	ELECTRIC UTILITY		18.91	
	<a href="#">100-3250-7010-010A</a>	UTILITIES (IA 10)	ELECTRIC UTILITY		40.98	
	<a href="#">100-3250-7010-012A</a>	UTILITIES (IA 12)	ELECTRIC UTILITY		76.07	
	<a href="#">100-3250-7010-014X</a>	UTILITIES (IA 14)	ELECTRIC UTILITY		37.10	
	<a href="#">100-3250-7010-019A</a>	UTILITIES (IA 19A)	ELECTRIC UTILITY		191.61	
	<a href="#">100-3250-7010-019C</a>	UTILITIES (IA 19C)	ELECTRIC UTILITY		183.87	
	<a href="#">100-3250-7010-06A1</a>	UTILITIES (IA 6A1)	ELECTRIC UTILITY		338.64	
	<a href="#">100-6050-7010-0000</a>	UTILITIES	ELECTRIC UTILITY		654.55	
	<a href="#">100-6050-7010-005X</a>	UTILITIES IA 5	ELECTRIC UTILITY		3,300.58	
	<a href="#">100-6050-7010-007A</a>	UTILITIES IA 7A	ELECTRIC UTILITY		10.97	
	<a href="#">100-6050-7010-020X</a>	UTILITIES IA 20	ELECTRIC UTILITY		11.12	
	<a href="#">100-6050-7010-06A1</a>	UTILITIES IA 6A1	ELECTRIC UTILITY		10.98	
	<a href="#">100-6050-7010-5400</a>	UTILITIES, PARK (SPORTS	ELECTRIC UTILITY		920.36	
	<a href="#">100-6050-7010-5500</a>	UTILITIES, PARK (STEWAR	ELECTRIC UTILITY		61.18	
2331	STAGECOACH TOWING	12/05/2019	Regular	0.00	85.00	104146
<b>Payable #</b>	<b>Payable Type</b>	<b>Post Date</b>	<b>Payable Description</b>	<b>Discount Amount</b>	<b>Payable Amount</b>	
	<b>Account Number</b>		<b>Account Name</b>	<b>Item Description</b>	<b>Distribution Amount</b>	
<a href="#">77397</a>	Invoice	12/04/2019	VEHICLE MAINTENANCE	0.00	85.00	
	<a href="#">100-2050-7037-0000</a>	VEHICLE MAINTENANCE	VEHICLE MAINTENANCE		85.00	
2360	STRADLING YOCCA CARLSON & RAUTH	12/05/2019	Regular	0.00	26,120.62	104147
<b>Payable #</b>	<b>Payable Type</b>	<b>Post Date</b>	<b>Payable Description</b>	<b>Discount Amount</b>	<b>Payable Amount</b>	
	<b>Account Number</b>		<b>Account Name</b>	<b>Item Description</b>	<b>Distribution Amount</b>	
<a href="#">THIRD PARTY CLA</a>	Invoice	12/04/2019	LEGAL SERVICES	0.00	26,120.62	
	<a href="#">120-9663-7300-0000</a>	CONTRACTUAL SERVICES	LEGAL SERVICES		26,120.62	
3854	SUNERGY CONSTRUCTION INC	12/05/2019	Regular	0.00	217.84	104148
<b>Payable #</b>	<b>Payable Type</b>	<b>Post Date</b>	<b>Payable Description</b>	<b>Discount Amount</b>	<b>Payable Amount</b>	
	<b>Account Number</b>		<b>Account Name</b>	<b>Item Description</b>	<b>Distribution Amount</b>	
<a href="#">RCT 925830</a>	Invoice	12/04/2019	REFUND CANCELLED PERMIT FEE BLD20	0.00	217.84	
	<a href="#">100-0000-4310-0000</a>	BUILDING PERMITS AND I	REFUND CANCELLED PERMIT FE		217.84	
2374	SWRCB ACCOUNTING OFFICE	12/05/2019	Regular	0.00	14,230.00	104149
<b>Payable #</b>	<b>Payable Type</b>	<b>Post Date</b>	<b>Payable Description</b>	<b>Discount Amount</b>	<b>Payable Amount</b>	
	<b>Account Number</b>		<b>Account Name</b>	<b>Item Description</b>	<b>Distribution Amount</b>	
<a href="#">SW-0179668</a>	Invoice	12/04/2019	PERMIT FEE	0.00	14,230.00	
	<a href="#">100-3250-7053-0000</a>	PERMITS, FEES AND LICE	PERMIT FEE		14,230.00	
2395	TERMINIX COMMERCIAL	12/05/2019	Regular	0.00	60.00	104150

Check Report

Date Range: 11/27/2019 - 019

2.

Vendor Number	Vendor Name	Payment Date	Payment Type	Discount Amount	Payment Amount	NU
Payable #	Payable Type	Post Date	Payable Description	Discount Amount	Payable Amount	
	Account Number	Account Name	Item Description	Distribution Amount		
391776601	Invoice <u>100-6000-7085-6055</u>	12/04/2019	BUILDING MAINTENANCE BLDG MAINT- FIRE STATIO	0.00	60.00	
2401	THALES CONSULTING Payable Type	12/05/2019	Regular	0.00	800.00	104151
1973	Invoice <u>100-1225-7068-0000</u>	12/04/2019	CONSULTING SERVICES CONTRACTUAL SERVICES	0.00	800.00	
2416	THE PRESS-ENTERPRISE Payable Type	12/05/2019	Regular	0.00	201.60	104152
0011332518	Invoice <u>100-1350-7020-0000</u>	12/04/2019	ADVERTISING ADVERTISING	0.00	81.00	
0011337002	Invoice <u>100-1350-7020-0000</u>	12/04/2019	ADVERTISING ADVERTISING	0.00	61.20	
0011337017	Invoice <u>100-1350-7020-0000</u>	12/04/2019	ADVERTISING ADVERTISING	0.00	59.40	
2419	THE RECORD GAZETTE Payable Type	12/05/2019	Regular	0.00	995.00	104153
1030034	Invoice <u>100-1200-7020-0000</u>	12/04/2019	ADVERTISING ADVERTISING	0.00	995.00	
2430	TIME WARNER CABLE Payable Type	12/05/2019	Regular	0.00	1,798.60	104154
0241971112519	Invoice <u>100-1230-7015-6025</u>	12/04/2019	CITY HALL INTERNET TELEPHONE (CITY HALL)	0.00	1,798.60	
2873	TPX COMMUNICATIONS Payable Type	12/05/2019	Regular	0.00	441.92	104155
123301040-0	Invoice <u>100-1230-7015-6040</u>	12/04/2019	PHONE UTILITY TELEPHONE (POLICE DPT)	0.00	441.92	
3855	UNBRANDED SCREEN PRINTING Payable Type	12/05/2019	Regular	0.00	340.00	104156
5642	Invoice <u>240-2300-7096-0000</u>	12/04/2019	SHOP WITH A COP T-SHIRTS PROGRAM COSTS - SHOP	0.00	340.00	
2466	UNITED RENTALS Payable Type	12/05/2019	Regular	0.00	1,139.14	104157
173026766-001	Invoice <u>100-6050-7068-5500</u>	12/05/2019	Goods CONTRACT SVC - STEWAR	0.00	1,139.14	
2472	UPS Payable Type	12/05/2019	Regular	0.00	17.08	104158
000087R790479	Invoice <u>100-1225-7025-0000</u>	12/04/2019	SHIPPING SERVICES OFFICE SUPPLIES	0.00	17.08	
2490	VERIZON BUSINESS SERVICE Payable Type	12/05/2019	Regular	0.00	1,616.99	104159



Vendor Number	Vendor Name	Payment Date	Payment Type	Discount Amount	Payment Amount	Num
Payable #	Payable Type	Post Date	Payable Description	Discount Amount	Payable Amount	
	Account Number	Account Name	Item Description	Distribution Amount		
71297614	Invoice 100-1230-7015-6040	12/04/2019	PHONE UTILITY TELEPHONE (POLICE DPT)	PHONE UTILITY	0.00	1,616.99
2517	VOYAGER	12/05/2019	Regular	0.00	45,623.87	104160
869065003948	Invoice 100-2000-7050-0000 100-2030-7050-0000 100-2050-7050-0000 100-2100-7050-0000 100-2150-7050-0000 100-3250-7050-0000 100-6050-7050-0000 700-4050-7050-0000 750-7100-7050-0000 750-7300-7050-0000 750-7400-7050-0000 750-7600-7050-0000 750-7700-7050-0000 750-7800-7050-0000 750-7900-7050-0000 750-8100-7050-0000 750-8200-7050-0000	12/04/2019	FUEL EXPENSE	FUEL EXPENSE	0.00	45,623.87
			FUEL	FUEL EXPENSE		568.54
			FUEL	FUEL EXPENSE		121.75
			FUEL	FUEL EXPENSE		13,282.49
			FUEL	FUEL EXPENSE		258.26
			FUEL	FUEL EXPENSE		312.14
			FUEL	FUEL EXPENSE		2,543.60
			FUEL	FUEL EXPENSE		5,666.18
			FUEL	FUEL EXPENSE		1,569.62
			FUEL	FUEL EXPENSE		3,993.39
			FUEL	FUEL EXPENSE		386.75
			FUEL	FUEL EXPENSE		7,721.23
			FUEL	FUEL EXPENSE		1,806.52
			FUEL	FUEL EXPENSE		2,948.18
			FUEL	FUEL EXPENSE		952.02
			FUEL	FUEL EXPENSE		2,369.01
			FUEL	FUEL EXPENSE		551.58
			FUEL	FUEL EXPENSE		572.61
2520	WALMART	12/05/2019	Regular	0.00	2,200.00	104161
12/04/19	Invoice 240-2300-7096-0000	12/04/2019	GIFT CARDS FOR SHOP WITH A COP PROGRAM COSTS - SHOP	GIFT CARDS FOR SHOP WITH A	0.00	2,200.00
2520	WALMART	12/05/2019	Regular	0.00	73.29	104162
P9273009301FHE	Invoice 100-1550-7040-0000	12/04/2019	HALLOWEEN EVENT RECREATION PROGRAMS	HALLOWEEN EVENT SUPPLIES	0.00	12.73
P9273009501G4	Invoice 100-1550-7040-0000	12/04/2019	HALLOWEEN EVENT SUPPLIES RECREATION PROGRAMS	HALLOWEEN EVENT SUPPLIES	0.00	54.27
P9273009901H8F	Invoice 100-6050-7070-0000 100-6150-7070-0000	12/04/2019	DEPT SUPPLIES SPECIAL DEPT SUPPLIES SPECIAL DEPT SUPPLIES	DEPT SUPPLIES DEPT SUPPLIES	0.00	6.29

Bank Code APBNK Summary

Payment Type	Payable Count	Payment Count	Discount	Payment
Regular Checks	158	69	0.00	598,202.14
Manual Checks	0	0	0.00	0.00
Voided Checks	0	2	0.00	0.00
Bank Drafts	0	0	0.00	0.00
EFT's	1	1	0.00	184,288.28
	159	72	0.00	782,490.42



### All Bank Codes Check Summary

Payment Type	Payable Count	Payment Count	Discount	Payment
Regular Checks	158	69	0.00	598,202.14
Manual Checks	0	0	0.00	0.00
Voided Checks	0	2	0.00	0.00
Bank Drafts	0	0	0.00	0.00
EFT's	1	1	0.00	184,288.28
	<b>159</b>	<b>72</b>	<b>0.00</b>	<b>782,490.42</b>

### Fund Summary

Fund	Name	Period	Amount
999	POOLED CASH	11/2019	184,288.28
999	POOLED CASH	12/2019	598,202.14
			<b>782,490.42</b>



**WARRANTS TO BE RATIFIED**

Thursday, December 12, 2019

<b>Printed Checks</b>	104163-104237	\$	385,664.37	FY 19/20
<b>ACH</b>	234-235	\$	9,206.97	
	A/P Total	\$	<u>394,871.34</u>	
<b>Bank Drafts</b>	Guardian	\$	21,518.02	Dec-19
	Affant	\$	555.50	Dec-19
	Utility Payment Bank Draft Returns	\$	1,384.96	
<b>Payroll</b>	Pay Date 12/06/19	\$	472,309.31	

I DO HEREBY CERTIFY THIS WARRANT LIST HAS BEEN COMPILED AND PREPARED TO MEET THE DAILY OPERATIONS FOR THE FISCAL YEAR JULY 1, 2019 - JUNE 30, 2020

SIGNATURE:   
 TITLE: CITY TREASURER

SIGNATURE:   
 TITLE: ADMINISTRATIVE SERVICES DIRECTOR



Vendor Number	Vendor Name	Payment Date	Payment Type	Discount Amount	Payment Amount	Number
3229	ICMA - RC	12/12/2019	EFT	0.00	7,530.90	234
<b>Payable #</b>	<b>Payable Type</b>	<b>Post Date</b>	<b>Payable Description</b>	<b>Discount Amount</b>	<b>Payable Amount</b>	
<u>PD 12/06/19</u>	Invoice	12/11/2019	EMPLOYEE CONTRIBUTION	0.00	7,530.90	
	<u>100-0000-2075-0000</u>		DEFERRED COMPENSATI		5,231.33	
	<u>100-0000-2075-0000</u>		DEFERRED COMPENSATI		112.37	
	<u>100-1200-6026-0000</u>		DEFERRED COMP		2,187.20	
2264	SEIU	12/12/2019	EFT	0.00	1,676.07	235
<b>Payable #</b>	<b>Payable Type</b>	<b>Post Date</b>	<b>Payable Description</b>	<b>Discount Amount</b>	<b>Payable Amount</b>	
<u>PD 12/06/19</u>	Invoice	12/11/2019	EMPLOYEE CONTRIBUTIONS	0.00	1,676.07	
	<u>100-0000-2061-0000</u>		P.E.R.C. DUES & INS		1,676.07	
2988	RHONDA KEYSER	12/10/2019	Regular	0.00	1,525.84	104163
<b>Payable #</b>	<b>Payable Type</b>	<b>Post Date</b>	<b>Payable Description</b>	<b>Discount Amount</b>	<b>Payable Amount</b>	
<u>12/04/19 CHECK</u>	Invoice	12/10/2019	PAYROLL SPOUSAL SUPPORT	0.00	1,525.84	
	<u>100-0000-2105-0000</u>		PAYROLL SUSPENSE		1,525.84	
3865	84 LUMBER COMPANY	12/12/2019	Regular	0.00	250.22	104164
<b>Payable #</b>	<b>Payable Type</b>	<b>Post Date</b>	<b>Payable Description</b>	<b>Discount Amount</b>	<b>Payable Amount</b>	
<u>2131-320834</u>	Invoice	12/12/2019	SUPPLIES FOR COUNCIL CHAMBER PROJE	0.00	183.09	
	<u>500-0000-8950-0000</u>		CAPITAL OUTLAY		183.09	
<u>2131-320844</u>	Invoice	12/12/2019	SUPPLIES FOR COUNCIL CHAMBERS PROJ	0.00	67.13	
	<u>500-0000-8990-0000</u>		CAPITAL OUTLAY		67.13	
1023	ADVANCED WORKPLACE STRATEGIES	12/12/2019	Regular	0.00	142.00	104165
<b>Payable #</b>	<b>Payable Type</b>	<b>Post Date</b>	<b>Payable Description</b>	<b>Discount Amount</b>	<b>Payable Amount</b>	
<u>412730</u>	Invoice	12/11/2019	EMPLOYEE MEDICAL SERVICES	0.00	142.00	
	<u>100-6050-6019-0000</u>		FIRST AID		142.00	
1036	ALBERT A. WEBB ASSOCIATES	12/12/2019	Regular	0.00	107,802.39	104166
<b>Payable #</b>	<b>Payable Type</b>	<b>Post Date</b>	<b>Payable Description</b>	<b>Discount Amount</b>	<b>Payable Amount</b>	
<u>194826</u>	Invoice	12/12/2019	Engineering Services During Construction	0.00	77,840.79	
	<u>710-0000-7068-0000</u>		CONTRACTUAL SERVICE		77,840.79	
<u>194827</u>	Invoice	12/12/2019	Engineering Services During Const. - BRIN	0.00	19,493.46	
	<u>710-0000-7068-0000</u>		CONTRACTUAL SERVICE		19,493.46	
<u>194828</u>	Invoice	12/12/2019	Engineering Services During Construction	0.00	5,652.80	
	<u>710-0000-7068-0000</u>		CONTRACTUAL SERVICE		5,652.80	
<u>194828-2</u>	Invoice	12/12/2019	Engineering Services During Const. - BRIN	0.00	4,815.34	
	<u>710-0000-7068-0000</u>		CONTRACTUAL SERVICE		4,815.34	
1042	ALL PURPOSE RENTALS	12/12/2019	Regular	0.00	790.46	104167
<b>Payable #</b>	<b>Payable Type</b>	<b>Post Date</b>	<b>Payable Description</b>	<b>Discount Amount</b>	<b>Payable Amount</b>	
<u>39413</u>	Invoice	12/12/2019	EQUIPMENT RENTALS - STREETS	0.00	185.02	
	<u>100-3250-7075-0000</u>		EQUIPMENT LEASING/RE		185.02	
<u>39642</u>	Invoice	12/11/2019	EQUIPMENT RENTAL	0.00	201.52	

Check Report

Date Range: 12/06/2019 - 12/31/2019

2.

Vendor Number	Vendor Name	Payment Date	Payment Type	Discount Amount	Payment Amount	Num
	<u>500-0000-8990-0000</u>		CAPITAL OUTLAY		201.52	
<u>39657</u>	Invoice	12/11/2019	EQUIPMENT RENTAL	0.00	201.52	
	<u>500-0000-8990-0000</u>		CAPITAL OUTLAY		201.52	
<u>39672</u>	Invoice	12/12/2019	EQUIPMENT RENTALS - STREETS	0.00	13.20	
	<u>100-3250-7075-0000</u>		EQUIPMENT LEASING/RE		13.20	
<u>39705</u>	Invoice	12/12/2019	EQUIPMENT RENTALS - STREETS	0.00	189.20	
	<u>100-3250-7075-0000</u>		EQUIPMENT LEASING/RE		189.20	
1050	AMAZON CAPITAL SERVICES	12/12/2019	Regular	0.00	472.57	104168
<b>Payable #</b>	<b>Payable Type</b>	<b>Post Date</b>	<b>Payable Description</b>	<b>Discount Amount</b>	<b>Payable Amount</b>	
	<b>Account Number</b>		<b>Account Name</b>		<b>Distribution Amount</b>	
<u>11DL-LHFD-RJFO</u>	Invoice	12/11/2019	DEPT SUPPLIES	0.00	29.62	
	<u>500-0000-8990-0000</u>		CAPITAL OUTLAY		29.62	
<u>14MN-PWL1-HH</u>	Invoice	12/11/2019	COMPUTER SUPPLIES & MAINTENANCE	0.00	102.92	
	<u>100-1230-7072-6040</u>		COMPUTER SUPPLIES/MA		102.92	
<u>1CLV-WP4F-YTFH</u>	Invoice	12/11/2019	COMPUTER SUPPLIES & MAINTENANCE	0.00	37.14	
	<u>100-1230-7072-6040</u>		COMPUTER SUPPLIES/MA		37.14	
<u>1G36-SQK7-G3FN</u>	Invoice	12/11/2019	COMPUTER SUPPLIES & MAINTENANCE	0.00	107.73	
	<u>100-1230-7072-6040</u>		COMPUTER SUPPLIES/MA		107.73	
<u>1JKN-XVT6-GF71</u>	Invoice	12/11/2019	COMPUTER SUPPLIES & MAINTENANCE	0.00	129.29	
	<u>100-1230-7072-6040</u>		COMPUTER SUPPLIES/MA		129.29	
<u>1PCW-QW97-DIT</u>	Invoice	12/11/2019	COMPUTER SUPPLIES & MAINTENANCE	0.00	29.61	
	<u>100-1230-7072-6040</u>		COMPUTER SUPPLIES/MA		29.61	
<u>1XFF-N9HJ-HJ9M</u>	Invoice	12/11/2019	OFFICE SUPPLIES	0.00	36.26	
	<u>100-1200-7025-0000</u>		OFFICE SUPPLIES		36.26	
1053	AMERICAN FORENSIC NURSES	12/12/2019	Regular	0.00	224.00	104169
<b>Payable #</b>	<b>Payable Type</b>	<b>Post Date</b>	<b>Payable Description</b>	<b>Discount Amount</b>	<b>Payable Amount</b>	
	<b>Account Number</b>		<b>Account Name</b>		<b>Distribution Amount</b>	
<u>72800</u>	Invoice	12/12/2019	American Forensic Nurses - Services	0.00	168.00	
	<u>100-2050-7068-0000</u>		CONTRACTUAL SERVICES		168.00	
<u>72833</u>	Invoice	12/12/2019	American Forensic Nurses - Services	0.00	56.00	
	<u>100-2050-7068-0000</u>		CONTRACTUAL SERVICES		56.00	
3820	AXON ENTERPRISE, INC	12/12/2019	Regular	0.00	15,516.00	104170
<b>Payable #</b>	<b>Payable Type</b>	<b>Post Date</b>	<b>Payable Description</b>	<b>Discount Amount</b>	<b>Payable Amount</b>	
	<b>Account Number</b>		<b>Account Name</b>		<b>Distribution Amount</b>	
<u>SI-1624991</u>	Invoice	12/12/2019	Purchase of 20 Tasers for Replacement	0.00	15,516.00	
	<u>100-2650-7070-0000</u>		SPECIAL DEPT SUPPLIES		15,516.00	
1125	BEAUMONT CHAMBER	12/12/2019	Regular	0.00	300.00	104171
<b>Payable #</b>	<b>Payable Type</b>	<b>Post Date</b>	<b>Payable Description</b>	<b>Discount Amount</b>	<b>Payable Amount</b>	
	<b>Account Number</b>		<b>Account Name</b>		<b>Distribution Amount</b>	
<u>9147</u>	Invoice	12/11/2019	MEMBERSHIP RENEWAL	0.00	300.00	
	<u>100-1200-7030-0000</u>		DUES & SUBSCRIPTIONS		300.00	
1127	BEAUMONT DO IT BEST HOME CENTER	12/12/2019	Regular	0.00	172.20	104172
<b>Payable #</b>	<b>Payable Type</b>	<b>Post Date</b>	<b>Payable Description</b>	<b>Discount Amount</b>	<b>Payable Amount</b>	
	<b>Account Number</b>		<b>Account Name</b>		<b>Distribution Amount</b>	
<u>479773</u>	Invoice	12/12/2019	DEPARTMENT SUPPLIES - SEWER	0.00	35.87	
	<u>700-4050-7070-0000</u>		SPECIAL DEPT SUPPLIES		35.87	
<u>480170</u>	Invoice	12/12/2019	DEPARTMENT SUPPLIES - STREETS	0.00	4.35	
	<u>100-3250-7070-0000</u>		SPECIAL DEPT SUPPLIES		4.35	
<u>480262</u>	Invoice	12/12/2019	DEPARTMENT SUPPLIES - STREETS	0.00	4.19	
	<u>100-3250-7070-0000</u>		SPECIAL DEPT SUPPLIES		4.19	
<u>480502</u>	Invoice	12/12/2019	DEPARTMENT SUPPLIES - STREETS	0.00	43.61	

Check Report

Date Range: 12/06/2019 - 12/31/2019

2.

Vendor Number	Vendor Name	Payment Date	Payment Type	Discount Amount	Payment Amount	Num
	<u>100-3250-7070-0000</u>		SPECIAL DEPT SUPPLIES		43.61	
<u>480570</u>	Invoice	12/11/2019	BUILDING MAINTENANCE	0.00	23.41	
	<u>100-6000-7085-6045</u>		BLDG MAINT- COMMUNI		23.41	
<u>480704</u>	Invoice	12/12/2019	DEPARTMENT SUPPLIES - SEWER	0.00	16.82	
	<u>700-4050-7070-0000</u>		SPECIAL DEPT SUPPLIES		16.82	
<u>480772</u>	Invoice	12/12/2019	DEPARTMENT SUPPLIES - SEWER	0.00	9.77	
	<u>700-4050-7070-0000</u>		SPECIAL DEPT SUPPLIES		9.77	
<u>480841</u>	Invoice	12/11/2019	BUILDING MAINTENANCE	0.00	12.08	
	<u>100-6000-7085-6025</u>		BLDG MAINT - CITY HALL		12.08	
<u>480865</u>	Invoice	12/11/2019	BUILDING MAINTENANCE	0.00	22.10	
	<u>100-6000-7085-6025</u>		BLDG MAINT - CITY HALL		22.10	
1136	BEAUMONT POWER EQUIPMENT	12/12/2019	Regular	0.00	10.00	104173
<b>Payable #</b>	<b>Payable Type</b>	<b>Post Date</b>	<b>Payable Description</b>	<b>Discount Amount</b>	<b>Payable Amount</b>	
	<b>Account Number</b>		<b>Account Name</b>		<b>Distribution Amount</b>	
<u>2782</u>	Invoice	12/11/2019	EQUIPMENT MAINTENANCE	0.00	10.00	
	<u>100-6000-7090-0000</u>		EQUIPMENT SUPPLIES/M		10.00	
1161	BIO-TOX LABORATORIES	12/12/2019	Regular	0.00	448.00	104174
<b>Payable #</b>	<b>Payable Type</b>	<b>Post Date</b>	<b>Payable Description</b>	<b>Discount Amount</b>	<b>Payable Amount</b>	
	<b>Account Number</b>		<b>Account Name</b>		<b>Distribution Amount</b>	
<u>38955</u>	Invoice	12/12/2019	Bio Tox Blood Draw Analysis	0.00	448.00	
	<u>100-2050-7068-0000</u>		CONTRACTUAL SERVICES		448.00	
3858	BRYAN GUERRERO	12/12/2019	Regular	0.00	40.00	104175
<b>Payable #</b>	<b>Payable Type</b>	<b>Post Date</b>	<b>Payable Description</b>	<b>Discount Amount</b>	<b>Payable Amount</b>	
	<b>Account Number</b>		<b>Account Name</b>		<b>Distribution Amount</b>	
<u>RCT 949904</u>	Invoice	12/11/2019	DEPOSIT REFUND	0.00	40.00	
	<u>100-0000-4590-0000</u>		BUILDING RENTAL		40.00	
1210	CALIFORNIA STATE FIRE PROTECTION	12/12/2019	Regular	0.00	1,156.29	104176
<b>Payable #</b>	<b>Payable Type</b>	<b>Post Date</b>	<b>Payable Description</b>	<b>Discount Amount</b>	<b>Payable Amount</b>	
	<b>Account Number</b>		<b>Account Name</b>		<b>Distribution Amount</b>	
<u>5397897 CHECK 2</u>	Invoice	12/11/2019	EQUIPMENT MAINTENANCE	0.00	328.17	
	<u>100-6000-7090-6040</u>		EQUIPMENT SUPPLIES/M		328.17	
<u>5594382 CHECK 2</u>	Invoice	12/11/2019	EQUIPMENT MAINTENANCE	0.00	322.43	
	<u>100-6000-7090-6045</u>		EQUIPMENT SUPPLIES/M		233.54	
	<u>100-6050-7090-0000</u>		EQUIPMENT SUPPLIES/M		88.89	
<u>5594568 CHECK 2</u>	Invoice	12/11/2019	EQUIPMENT MAINTENANCE	0.00	505.69	
	<u>100-6000-7090-6025</u>		EQUIPMENT SUPPLIES/M		352.15	
	<u>100-6050-7090-0000</u>		EQUIPMENT SUPPLIES/M		129.30	
	<u>100-6050-7090-0000</u>		EQUIPMENT SUPPLIES/M		24.24	
1227	CARROT-TOP INDUSTRIES INC	12/12/2019	Regular	0.00	861.41	104177
<b>Payable #</b>	<b>Payable Type</b>	<b>Post Date</b>	<b>Payable Description</b>	<b>Discount Amount</b>	<b>Payable Amount</b>	
	<b>Account Number</b>		<b>Account Name</b>		<b>Distribution Amount</b>	
<u>44246100 CHECK</u>	Invoice	12/11/2019	BUILDING MAINTENANCE	0.00	221.80	
	<u>100-6000-7085-6040</u>		BLDG MAINT - POLICE DE		221.80	
<u>44246300 CHECK</u>	Invoice	12/11/2019	BUILDING MAINTENANCE	0.00	240.65	
	<u>100-6000-7085-6025</u>		BLDG MAINT - CITY HALL		240.65	
<u>44276600 CHECK</u>	Invoice	12/11/2019	BUILDING MAINTENANCE	0.00	82.19	
	<u>100-6000-7085-6025</u>		BLDG MAINT - CITY HALL		82.19	
<u>44440200</u>	Invoice	12/11/2019	EQUIPMENT MAINTENANCE	0.00	316.77	
	<u>100-6000-7090-6025</u>		EQUIPMENT SUPPLIES/M		316.77	
1238	CDW GOVERNMENT, INC.	12/12/2019	Regular	0.00	1,784.55	104178

Check Report

Date Range: 12/06/2019 - 12/13/2019

2.

Vendor Number	Vendor Name	Payment Date	Payment Type	Discount Amount	Payment Amount	Num
Payable #	Payable Type	Post Date	Payable Description	Discount Amount	Payable Amount	
	Account Number	Account Name	Item Description	Distribution Amount		
<u>VRB6194</u>	Invoice	12/11/2019	COMPUTER SUPPLIES	0.00	38.08	
	<u>100-1230-7072-0000</u>		COMPUTER SUPPLIES/MA		38.08	
<u>VSV0527</u>	Invoice	12/11/2019	COMPUTER SUPPLIES FOR PUBLIC WORKS	0.00	124.27	
	<u>100-1230-7072-0000</u>		COMPUTER SUPPLIES/MA		124.27	
<u>VTW5382</u>	Invoice	12/11/2019	COMPUTER SUPPLIES FOR PUBLIC WORKS	0.00	1,622.20	
	<u>100-1230-7072-0000</u>		COMPUTER SUPPLIES/MA		1,622.20	
1285	CITY OF BANNING	12/12/2019	Regular	0.00	134.30	104179
Payable #	Payable Type	Post Date	Payable Description	Discount Amount	Payable Amount	
	Account Number	Account Name	Item Description	Distribution Amount		
<u>74105-54930 12/</u>	Invoice	12/12/2019	SHARED TRAFFIC SIGNAL UTILITY @ HS W	0.00	63.83	
	<u>100-3250-7010-0000</u>		UTILITIES		63.83	
<u>74105-54930 12/</u>	Invoice	12/12/2019	SHARED TRAFFIC SIGNAL UTILITY @ HS W	0.00	70.47	
	<u>100-3250-7010-0000</u>		UTILITIES		70.47	
1342	CR&R INC.	12/12/2019	Regular	0.00	8,718.60	104180
Payable #	Payable Type	Post Date	Payable Description	Discount Amount	Payable Amount	
	Account Number	Account Name	Item Description	Distribution Amount		
<u>0002167</u>	Invoice	12/12/2019	Street Sweeping Services	0.00	8,718.60	
	<u>100-3250-7068-0000</u>		CONTRACTUAL SERVICES		8,718.60	
1391	DEKRA-LITE IND.,INC.	12/12/2019	Regular	0.00	3,470.96	104181
Payable #	Payable Type	Post Date	Payable Description	Discount Amount	Payable Amount	
	Account Number	Account Name	Item Description	Distribution Amount		
<u>ARINV010116</u>	Invoice	12/12/2019	FALL 2019 INSTALLATION OF 13 MILITARY	0.00	3,470.96	
	<u>240-2350-7070-0000</u>		SPEC DEPT SUPPLIES - MI		3,470.96	
3305	DEPT OF THE CA HIGHWAY PATROL	12/12/2019	Regular	0.00	34,166.07	104182
Payable #	Payable Type	Post Date	Payable Description	Discount Amount	Payable Amount	
	Account Number	Account Name	Item Description	Distribution Amount		
<u>R18-655-0003</u>	Invoice	12/12/2019	TRAFFIC CONTROL FOR POTRERO BRIDGE	0.00	34,166.07	
	<u>500-0000-8030-0000</u>		INFRASTRUCTURE IMPRO		34,166.07	
1477	ENGINEERING RESOURCES OF SOUTHERN CALII	12/12/2019	Regular	0.00	14,506.53	104183
Payable #	Payable Type	Post Date	Payable Description	Discount Amount	Payable Amount	
	Account Number	Account Name	Item Description	Distribution Amount		
<u>53094</u>	Invoice	12/12/2019	INSPECTION SERVICES	0.00	315.00	
	<u>100-3100-7067-0000</u>		INSPECTIONS		315.00	
<u>53095</u>	Invoice	12/12/2019	INSPECTION SERVICES	0.00	131.25	
	<u>100-3100-7067-0000</u>		INSPECTIONS		131.25	
<u>53096</u>	Invoice	12/12/2019	INSPECTION SERVICES	0.00	210.00	
	<u>100-3100-7067-0000</u>		INSPECTIONS		210.00	
<u>53097</u>	Invoice	12/12/2019	INSPECTION SERVICES	0.00	918.75	
	<u>100-3100-7067-0000</u>		INSPECTIONS		918.75	
<u>53098</u>	Invoice	12/12/2019	INSPECTION SERVICES	0.00	52.50	
	<u>100-3100-7067-0000</u>		INSPECTIONS		52.50	
<u>53099</u>	Invoice	12/12/2019	INSPECTION SERVICES	0.00	787.50	
	<u>100-3100-7067-0000</u>		INSPECTIONS		787.50	
<u>53100</u>	Invoice	12/12/2019	INSPECTION SERVICES	0.00	52.50	
	<u>100-3100-7067-0000</u>		INSPECTIONS		52.50	
<u>53101</u>	Invoice	12/12/2019	INSPECTION SERVICES	0.00	525.00	
	<u>100-3100-7067-0000</u>		INSPECTIONS		525.00	
<u>53102</u>	Invoice	12/12/2019	INSPECTION SERVICES	0.00	52.50	
	<u>100-3100-7067-0000</u>		INSPECTIONS		52.50	
<u>53103</u>	Invoice	12/12/2019	INSPECTION SERVICES	0.00	603.75	



Check Report

Date Range: 12/06/2019 - 12/31/2019

2.

Vendor Number	Vendor Name	Payment Date	Payment Type	Discount Amount	Payment Amount	Num
	<u>100-3100-7067-0000</u>		INSPECTIONS		603.75	
<u>53104</u>	Invoice	12/12/2019	INSPECTION SERVICES	0.00	78.75	
	<u>100-3100-7067-0000</u>		INSPECTIONS		78.75	
<u>53105</u>	Invoice	12/12/2019	INSPECTION SERVICES	0.00	472.50	
	<u>100-3100-7067-0000</u>		INSPECTIONS		472.50	
<u>53106</u>	Invoice	12/12/2019	INSPECTION SERVICES	0.00	2,336.25	
	<u>100-3100-7067-0000</u>		INSPECTIONS		2,336.25	
<u>53107</u>	Invoice	12/12/2019	ENGINEERING PLAN CHECK & ON CALL SU	0.00	1,053.25	
	<u>100-3100-7063-0000</u>		PLAN CHECK FEES		1,053.25	
<u>53108</u>	Invoice	12/12/2019	ENGINEERING PLAN CHECK & ON CALL SU	0.00	375.57	
	<u>100-3100-7063-0000</u>		PLAN CHECK FEES		375.57	
<u>53109</u>	Invoice	12/12/2019	ENGINEERING PLAN CHECK & ON CALL SU	0.00	547.44	
	<u>100-3100-7063-0000</u>		PLAN CHECK FEES		547.44	
<u>53110</u>	Invoice	12/12/2019	ENGINEERING PLAN CHECK & ON CALL SU	0.00	1,607.30	
	<u>100-3100-7063-0000</u>		PLAN CHECK FEES		1,607.30	
<u>53111</u>	Invoice	12/12/2019	INSPECTION SERVICES	0.00	262.50	
	<u>100-3100-7067-0000</u>		INSPECTIONS		262.50	
<u>53112</u>	Invoice	12/12/2019	ENGINEERING PLAN CHECK & ON CALL SU	0.00	178.59	
	<u>100-3100-7063-0000</u>		PLAN CHECK FEES		178.59	
<u>53113</u>	Invoice	12/12/2019	ENGINEERING PLAN CHECK & ON CALL SU	0.00	1,373.79	
	<u>100-3100-7063-0000</u>		PLAN CHECK FEES		1,373.79	
<u>53114</u>	Invoice	12/12/2019	ENGINEERING PLAN CHECK & ON CALL SU	0.00	929.50	
	<u>100-3100-7063-0000</u>		PLAN CHECK FEES		929.50	
<u>53115</u>	Invoice	12/12/2019	ENGINEERING PLAN CHECK & ON CALL SU	0.00	1,642.34	
	<u>100-3100-7063-0000</u>		PLAN CHECK FEES		1,642.34	
1501	**Void**	12/12/2019	Regular	0.00	0.00	104184
	FAIRVIEW FORD	12/12/2019	Regular	0.00	32,246.83	104185
<b>Payable #</b>	<b>Payable Type</b>	<b>Post Date</b>	<b>Payable Description</b>	<b>Discount Amount</b>	<b>Payable Amount</b>	
	<b>Account Number</b>		<b>Account Name</b>		<b>Distribution Amount</b>	
<u>200152</u>	Invoice	12/12/2019	SOLID WASTE/RECYCLING VEHICLE	0.00	32,007.27	
	<u>100-3100-8060-0000</u>		VEHICLES		32,007.27	
<u>643907</u>	Invoice	12/11/2019	VEHICLE MAINTENANCE	0.00	239.56	
	<u>100-2050-7037-0000</u>		VEHICLE MAINTENANCE		239.56	
1522	FOX OCCUPATIONAL	12/12/2019	Regular	0.00	455.00	104186
<b>Payable #</b>	<b>Payable Type</b>	<b>Post Date</b>	<b>Payable Description</b>	<b>Discount Amount</b>	<b>Payable Amount</b>	
	<b>Account Number</b>		<b>Account Name</b>		<b>Distribution Amount</b>	
<u>113458</u>	Invoice	12/11/2019	EMPLOYEE MEDICAL SERVICES	0.00	455.00	
	<u>100-1240-6050-0000</u>		RECRUITMENT AND HIRI		210.00	
	<u>750-7100-6019-0000</u>		FIRST AID		40.00	
	<u>750-7200-6019-0000</u>		FIRST AID		80.00	
	<u>750-7300-6019-0000</u>		FIRST AID		80.00	
	<u>750-7400-6019-0000</u>		FIRST AID		45.00	
3860	FREEDOM FOREVER	12/12/2019	Regular	0.00	217.22	104187
<b>Payable #</b>	<b>Payable Type</b>	<b>Post Date</b>	<b>Payable Description</b>	<b>Discount Amount</b>	<b>Payable Amount</b>	
	<b>Account Number</b>		<b>Account Name</b>		<b>Distribution Amount</b>	
<u>BLDR7019-5426</u>	Invoice	12/11/2019	PERMIT CANCELLED, 80% REFUND OF PER	0.00	217.22	
	<u>100-0000-1310-0000</u>		BUILDING PERMITS AND I		217.22	
1533	FRONTIER COMMUNICATIONS	12/12/2019	Regular	0.00	154.71	104188
<b>Payable #</b>	<b>Payable Type</b>	<b>Post Date</b>	<b>Payable Description</b>	<b>Discount Amount</b>	<b>Payable Amount</b>	
	<b>Account Number</b>		<b>Account Name</b>		<b>Distribution Amount</b>	
<u>323-156-8188-02</u>	Invoice	12/11/2019	PHONE UTILITY	0.00	85.98	
	<u>100-1230-7015-6060</u>		TELEPHONE (4th ST YARD		85.98	

Check Report

Date Range: 12/06/2019 - 12/13/2019

2.

Vendor Number	Vendor Name	Payment Date	Payment Type	Discount Amount	Payment Amount	Num
<u>951-769-6032-08</u>	Invoice	12/11/2019	PHONE UTILITY	0.00	68.73	
	<u>100-1230-7015-5400</u>		TELEPHONE - SPORTS PAR		68.73	
3042	GOLDEN STAR TECHNOLOGY, INC	12/12/2019	Regular	0.00	9,190.00	104189
<b>Payable #</b>	<b>Payable Type</b>	<b>Post Date</b>	<b>Payable Description</b>	<b>Discount Amount</b>	<b>Payable Amount</b>	
<u>INV41282</u>	Invoice	12/12/2019	Golden Star Technology - IT Consulting Se	0.00	9,190.00	
	<u>100-1230-7068-6025</u>		CONTRACT SVC - CITY HA		4,595.00	
	<u>100-1230-7068-6040</u>		CONTRACT SVC - P.D.		4,595.00	
3861	GRACE GRANADOS	12/12/2019	Regular	0.00	40.00	104190
<b>Payable #</b>	<b>Payable Type</b>	<b>Post Date</b>	<b>Payable Description</b>	<b>Discount Amount</b>	<b>Payable Amount</b>	
<u>RCT 947014</u>	Invoice	12/11/2019	DEPOSIT REFUND	0.00	40.00	
	<u>100-0000-4590-0000</u>		BUILDING RENTAL		40.00	
3795	GV CONSTRUCTION, INC	12/12/2019	Regular	0.00	14,070.00	104191
<b>Payable #</b>	<b>Payable Type</b>	<b>Post Date</b>	<b>Payable Description</b>	<b>Discount Amount</b>	<b>Payable Amount</b>	
<u>1009</u>	Invoice	12/12/2019	DESIGN AND BUILD OF COUNCIL FURNITU	0.00	14,070.00	
	<u>500-0000-8990-0000</u>		CAPITAL OUTLAY		14,070.00	
3718	HAAKER EQUIPMENT COMPANY	12/12/2019	Regular	0.00	1,080.37	104192
<b>Payable #</b>	<b>Payable Type</b>	<b>Post Date</b>	<b>Payable Description</b>	<b>Discount Amount</b>	<b>Payable Amount</b>	
<u>W58274</u>	Invoice	12/12/2019	EQUIPMENT MAINTENANCE FOR VACTOR	0.00	1,080.37	
	<u>700-4050-7037-0000</u>		VEHICLE MAINTENANCE		1,080.37	
1624	HIGH TECH IRRIGATION, INC.	12/12/2019	Regular	0.00	1,745.23	104193
<b>Payable #</b>	<b>Payable Type</b>	<b>Post Date</b>	<b>Payable Description</b>	<b>Discount Amount</b>	<b>Payable Amount</b>	
<u>610974</u>	Invoice	12/11/2019	DEPT SUPPLIES	0.00	1,622.75	
	<u>100-6050-7070-5999</u>		SPEC DEPT EXP - ALL PAR		1,622.75	
<u>610974-2</u>	Invoice	12/11/2019	DEPT SUPPLIES	0.00	122.48	
	<u>100-6050-7070-5999</u>		SPEC DEPT EXP - ALL PAR		122.48	
1628	HINDERLITER, de LLAMAS, & ASSOC	12/12/2019	Regular	0.00	2,749.02	104194
<b>Payable #</b>	<b>Payable Type</b>	<b>Post Date</b>	<b>Payable Description</b>	<b>Discount Amount</b>	<b>Payable Amount</b>	
<u>0032449-IN</u>	Invoice	12/11/2019	SALES QUARTER 2 2019	0.00	2,749.02	
	<u>100-1200-7068-0000</u>		CONTRACTUAL SERVICES		2,749.02	
1643	HUNTINGTON COURT REPORTERS & TRANSCRI	12/12/2019	Regular	0.00	463.60	104195
<b>Payable #</b>	<b>Payable Type</b>	<b>Post Date</b>	<b>Payable Description</b>	<b>Discount Amount</b>	<b>Payable Amount</b>	
<u>32501</u>	Invoice	12/12/2019	Transcription Services	0.00	463.60	
	<u>100-2050-7068-0000</u>		CONTRACTUAL SERVICES		463.60	
1662	INFOSEND, INC	12/12/2019	Regular	0.00	2,397.88	104196
<b>Payable #</b>	<b>Payable Type</b>	<b>Post Date</b>	<b>Payable Description</b>	<b>Discount Amount</b>	<b>Payable Amount</b>	
<u>161634</u>	Invoice	12/11/2019	PROFESSIONAL SERVICES	0.00	2,397.88	
	<u>700-4050-7068-0000</u>		CONTRACTUAL SERVICES		2,397.88	
1679	INTERWEST CONSULTING GRP, INC.	12/12/2019	Regular	0.00	17,275.00	104197
<b>Payable #</b>	<b>Payable Type</b>	<b>Post Date</b>	<b>Payable Description</b>	<b>Discount Amount</b>	<b>Payable Amount</b>	
<u>53164</u>	Invoice	12/12/2019	INTERWEST GIS SERVICES	0.00	10,430.00	
	<u>100-1230-7071-0000</u>		SOFTWARE		10,430.00	
<u>54147</u>	Invoice	12/12/2019	INTERWEST GIS SERVICES	0.00	2,782.50	

Check Report

Date Range: 12/06/2019 - 12/13/2019

2.

Vendor Number	Vendor Name	Payment Date	Payment Type	Discount Amount	Payment Amount	Num
	<u>100-1230-7071-0000</u>	SOFTWARE	INTERWEST GIS SERVICES		2,782.50	
<u>54975</u>	Invoice	12/12/2019	INTERWEST GIS SERVICES	0.00	4,062.50	
	<u>100-1230-7071-0000</u>	SOFTWARE	INTERWEST GIS SERVICES		4,062.50	
3862	KIMBERLY LAMB	12/12/2019	Regular	0.00	45.00	104198
<b>Payable #</b>	<b>Payable Type</b>	<b>Post Date</b>	<b>Payable Description</b>	<b>Discount Amount</b>	<b>Payable Amount</b>	
	<b>Account Number</b>	<b>Account Name</b>	<b>Item Description</b>	<b>Distribution Amount</b>		
<u>RCT 948625</u>	Invoice	12/11/2019	DEPOSIT REFUND	0.00	45.00	
	<u>100-0000-4590-0000</u>	BUILDING RENTAL	DEPOSIT REFUND		45.00	
3247	KOA CORPORATION	12/12/2019	Regular	0.00	9,754.50	104199
<b>Payable #</b>	<b>Payable Type</b>	<b>Post Date</b>	<b>Payable Description</b>	<b>Discount Amount</b>	<b>Payable Amount</b>	
	<b>Account Number</b>	<b>Account Name</b>	<b>Item Description</b>	<b>Distribution Amount</b>		
<u>JB74058X15</u>	Invoice	12/12/2019	California Grade Sep Engineering Design S	0.00	9,754.50	
	<u>500-0000-7068-0000</u>	CONTRACTUAL SERVICE	California Grade Sep Engineerin		9,754.50	
1805	KONICA MINOLTA BUSINESS SOLUTIONS	12/12/2019	Regular	0.00	1,319.16	104200
<b>Payable #</b>	<b>Payable Type</b>	<b>Post Date</b>	<b>Payable Description</b>	<b>Discount Amount</b>	<b>Payable Amount</b>	
	<b>Account Number</b>	<b>Account Name</b>	<b>Item Description</b>	<b>Distribution Amount</b>		
<u>9006292661</u>	Invoice	12/11/2019	EQUIPMENT MAINTENANCE	0.00	249.92	
	<u>100-1230-7090-6026</u>	EQUIP SUPPLIES/MAINT (	EQUIPMENT MAINTENANCE		149.95	
	<u>700-4050-7090-0000</u>	EQUIPMENT SUPPLIES/M	EQUIPMENT MAINTENANCE		99.97	
<u>9006293122</u>	Invoice	12/11/2019	PRINTER SERVICES	0.00	1,069.24	
	<u>100-1230-7090-6025</u>	EQUIP SUPPLIES/MAINT (	EQUIPMENT MAINTENANCE		476.59	
	<u>100-1230-7090-6040</u>	EQUIP SUPPLIES/MAINT (	EQUIPMENT MAINTENANCE		247.84	
	<u>100-1230-7090-6045</u>	EQUIP SUPPLIES/MAINT (	EQUIPMENT MAINTENANCE		105.48	
	<u>750-7000-7090-0000</u>	EQUIPMENT SUPPLIES/M	EQUIPMENT MAINTENANCE		239.33	
1806	KONICA MINOLTA PREMIER FINANCE	12/12/2019	Regular	0.00	600.17	104201
<b>Payable #</b>	<b>Payable Type</b>	<b>Post Date</b>	<b>Payable Description</b>	<b>Discount Amount</b>	<b>Payable Amount</b>	
	<b>Account Number</b>	<b>Account Name</b>	<b>Item Description</b>	<b>Distribution Amount</b>		
<u>401119474</u>	Invoice	12/11/2019	EQUIPMENT RENTAL PAGEWIDE 4000 CO	0.00	600.17	
	<u>100-1230-7075-6026</u>	EQUIPMENT LEASING/RE	EQUIPMENT RENTAL PAGEWIDE		420.12	
	<u>700-4050-7075-0000</u>	EQUIPMENT LEASING/RE	EQUIPMENT RENTAL PAGEWIDE		180.05	
3271	KS STATEBANK	12/12/2019	Regular	0.00	11,830.77	104202
<b>Payable #</b>	<b>Payable Type</b>	<b>Post Date</b>	<b>Payable Description</b>	<b>Discount Amount</b>	<b>Payable Amount</b>	
	<b>Account Number</b>	<b>Account Name</b>	<b>Item Description</b>	<b>Distribution Amount</b>		
<u>3353429 01/01/2</u>	Invoice	12/12/2019	VACTOR TRUCK & PATCH TRUCK	0.00	11,830.77	
	<u>100-3250-8060-0000</u>	VEHICLES	VACTOR TRUCK & PATCH TRUCK		3,194.30	
	<u>710-0000-8060-0000</u>	VEHICLES	VACTOR TRUCK & PATCH TRUCK		8,636.47	
3798	L.A. MERRITT, INC	12/12/2019	Regular	0.00	1,960.00	104203
<b>Payable #</b>	<b>Payable Type</b>	<b>Post Date</b>	<b>Payable Description</b>	<b>Discount Amount</b>	<b>Payable Amount</b>	
	<b>Account Number</b>	<b>Account Name</b>	<b>Item Description</b>	<b>Distribution Amount</b>		
<u>21400</u>	Invoice	12/12/2019	HIGHLAND SPRINGS AVE AS BUILT SURVE	0.00	1,960.00	
	<u>100-3100-7068-0000</u>	CONTRACTUAL SERVICES	HIGHLAND SPRINGS AVE AS BUI		1,960.00	
1827	LANGUAGE TESTING INTERNATIONAL	12/12/2019	Regular	0.00	70.00	104204
<b>Payable #</b>	<b>Payable Type</b>	<b>Post Date</b>	<b>Payable Description</b>	<b>Discount Amount</b>	<b>Payable Amount</b>	
	<b>Account Number</b>	<b>Account Name</b>	<b>Item Description</b>	<b>Distribution Amount</b>		
<u>L31963-IN</u>	Invoice	12/11/2019	PROFESSIONAL SERVICES	0.00	70.00	
	<u>100-1240-7068-0000</u>	CONTRACTUAL SERVICES	PROFESSIONAL SERVICES		70.00	
3379	LAW OFFICES BURKE, WILLIAMS & SORENSEN,	12/12/2019	Regular	0.00	1,624.00	104205
<b>Payable #</b>	<b>Payable Type</b>	<b>Post Date</b>	<b>Payable Description</b>	<b>Discount Amount</b>	<b>Payable Amount</b>	
	<b>Account Number</b>	<b>Account Name</b>	<b>Item Description</b>	<b>Distribution Amount</b>		
<u>244175</u>	Invoice	12/12/2019	LEGAL SERVICE	0.00	1,624.00	
	<u>120-9663-7300-0000</u>	CONTRACTUAL SERVICES	LEGAL SERVICE		1,624.00	

Check Report

Date Range: 12/06/2019 - 12/31/2019

2.

Vendor Number	Vendor Name	Payment Date	Payment Type	Discount Amount	Payment Amount	Num
3863	LEE PENRICE	12/12/2019	Regular	0.00	81.56	104206
<b>Payable #</b>	<b>Payable Type</b>	<b>Post Date</b>	<b>Payable Description</b>	<b>Discount Amount</b>	<b>Payable Amount</b>	
	<b>Account Number</b>	<b>Account Name</b>	<b>Item Description</b>	<b>Distribution Amount</b>		
<u>07-009431-02</u>	Invoice	12/11/2019	REIMBURSE CREDIT ON UTILITY ACCOUNT	0.00	81.56	
	<u>100-0000-1400-0000</u>		A/R - UTILITIES		81.56	
1853	LEWIS BRISBOIS BISGAARD & SMITH LLP	12/12/2019	Regular	0.00	1,079.01	104207
<b>Payable #</b>	<b>Payable Type</b>	<b>Post Date</b>	<b>Payable Description</b>	<b>Discount Amount</b>	<b>Payable Amount</b>	
	<b>Account Number</b>	<b>Account Name</b>	<b>Item Description</b>	<b>Distribution Amount</b>		
<u>2450648</u>	Invoice	12/12/2019	LEGAL SERVICES	0.00	45.00	
	<u>120-9863-7300-0000</u>		CONTRACTUAL SERVICES		45.00	
<u>2450649</u>	Invoice	12/12/2019	LEGAL SERVICES	0.00	1,034.01	
	<u>120-9663-7300-0000</u>		CONTRACTUAL SERVICES		1,034.01	
1895	M BREY ELECTRIC INC	12/12/2019	Regular	0.00	1,226.80	104208
<b>Payable #</b>	<b>Payable Type</b>	<b>Post Date</b>	<b>Payable Description</b>	<b>Discount Amount</b>	<b>Payable Amount</b>	
	<b>Account Number</b>	<b>Account Name</b>	<b>Item Description</b>	<b>Distribution Amount</b>		
<u>5489</u>	Invoice	12/11/2019	PROFESSIONAL SERVICES	0.00	1,226.80	
	<u>100-6050-7068-5500</u>		CONTRACT SVC - STEWAR		1,226.80	
1901	MANNING & KASS, ELLROD, RAMIREZ	12/12/2019	Regular	0.00	6,831.04	104209
<b>Payable #</b>	<b>Payable Type</b>	<b>Post Date</b>	<b>Payable Description</b>	<b>Discount Amount</b>	<b>Payable Amount</b>	
	<b>Account Number</b>	<b>Account Name</b>	<b>Item Description</b>	<b>Distribution Amount</b>		
<u>657987</u>	Invoice	12/12/2019	LEGAL SERVICES	0.00	6,831.04	
	<u>120-9663-7300-0000</u>		CONTRACTUAL SERVICES		6,831.04	
3864	MARC HARGETT	12/12/2019	Regular	0.00	40.00	104210
<b>Payable #</b>	<b>Payable Type</b>	<b>Post Date</b>	<b>Payable Description</b>	<b>Discount Amount</b>	<b>Payable Amount</b>	
	<b>Account Number</b>	<b>Account Name</b>	<b>Item Description</b>	<b>Distribution Amount</b>		
<u>RCT 946814</u>	Invoice	12/11/2019	DEPOSIT REFUND	0.00	40.00	
	<u>100-0000-4590-0000</u>		BUILDING RENTAL		40.00	
3193	MISAC	12/12/2019	Regular	0.00	227.50	104211
<b>Payable #</b>	<b>Payable Type</b>	<b>Post Date</b>	<b>Payable Description</b>	<b>Discount Amount</b>	<b>Payable Amount</b>	
	<b>Account Number</b>	<b>Account Name</b>	<b>Item Description</b>	<b>Distribution Amount</b>		
<u>300003345</u>	Invoice	12/11/2019	MEMBERSHIP 2019-2020 COREY CRAWFO	0.00	130.00	
	<u>100-1230-7030-0000</u>		DUES & SUBSCRIPTIONS		130.00	
<u>300003355</u>	Invoice	12/11/2019	MEMBERSHIP 2019-2020 CHRIS LITWIN J	0.00	97.50	
	<u>100-1230-7030-0000</u>		DUES & SUBSCRIPTIONS		97.50	
2892	MOFFATT & NICHOL	12/12/2019	Regular	0.00	1,079.00	104212
<b>Payable #</b>	<b>Payable Type</b>	<b>Post Date</b>	<b>Payable Description</b>	<b>Discount Amount</b>	<b>Payable Amount</b>	
	<b>Account Number</b>	<b>Account Name</b>	<b>Item Description</b>	<b>Distribution Amount</b>		
<u>743506</u>	Invoice	12/12/2019	ENVIROMENTAL DOC SERVICES FOR PENN	0.00	579.00	
	<u>500-0000-7068-0000</u>		CONTRACTUAL SERVICE		579.00	
<u>743520</u>	Invoice	12/12/2019	ENVIROMENTAL/REGULATORY PERMITIN	0.00	500.00	
	<u>500-0000-7068-0000</u>		CONTRACTUAL SERVICE		500.00	
3796	MOORE & ASSOCIATES, INC	12/12/2019	Regular	0.00	15,024.46	104213
<b>Payable #</b>	<b>Payable Type</b>	<b>Post Date</b>	<b>Payable Description</b>	<b>Discount Amount</b>	<b>Payable Amount</b>	
	<b>Account Number</b>	<b>Account Name</b>	<b>Item Description</b>	<b>Distribution Amount</b>		
<u>19:441?</u>	Invoice	12/12/2019	Comprehensive Operations Analysis	0.00	15,024.46	
	<u>750-7000-7068-0000</u>		CONTRACTUAL SERVICES		15,024.46	
1984	NAPA AUTO PARTS	12/12/2019	Regular	0.00	747.72	104214
<b>Payable #</b>	<b>Payable Type</b>	<b>Post Date</b>	<b>Payable Description</b>	<b>Discount Amount</b>	<b>Payable Amount</b>	
	<b>Account Number</b>	<b>Account Name</b>	<b>Item Description</b>	<b>Distribution Amount</b>		
<u>082572</u>	Invoice	12/11/2019	VEHICLE MAINTENANCE	0.00	7.97	
	<u>750-7300-7037-0000</u>		VEHICLE MAINTENANCE		7.97	

Check Report

Date Range: 12/06/2019 - 12/31/2019

2.

Vendor Number	Vendor Name	Payment Date	Payment Type	Discount Amount	Payment Amount	Num
<u>089977</u>	Invoice	12/11/2019	VEHICLE MAINTENANCE	0.00	34.47	
	<u>750-7300-7037-0000</u>		VEHICLE MAINTENANCE VEHICLE MAINTENANCE		34.47	
<u>091237</u>	Credit Memo	12/11/2019	RETURNED PARTS	0.00	-19.40	
	<u>100-2050-7037-0000</u>		VEHICLE MAINTENANCE RETURNED PARTS		-19.40	
<u>092004</u>	Invoice	12/11/2019	VEHICLE MAINTENANCE	0.00	23.68	
	<u>100-3250-7037-0000</u>		VEHICLE MAINTENANCE VEHICLE MAINTENANCE		23.68	
<u>094844</u>	Invoice	12/11/2019	VEHICLE MAINTENANCE	0.00	14.12	
	<u>750-7800-7037-0000</u>		VEHICLE MAINTENANCE VEHICLE MAINTENANCE		14.12	
<u>095924</u>	Invoice	12/11/2019	VEHICLE MAINTENANCE	0.00	38.78	
	<u>750-7300-7037-0000</u>		VEHICLE MAINTENANCE VEHICLE MAINTENANCE		38.78	
<u>100391</u>	Invoice	12/11/2019	VEHICLE MAINTENANCE	0.00	414.83	
	<u>750-7700-7037-0000</u>		VEHICLE MAINTENANCE VEHICLE MAINTENANCE		414.83	
<u>105340</u>	Invoice	12/11/2019	VEHICLE MAINTENANCE	0.00	16.45	
	<u>100-3250-7037-0000</u>		VEHICLE MAINTENANCE VEHICLE MAINTENANCE		16.45	
<u>105383</u>	Invoice	12/11/2019	VEHICLE MAINTENANCE	0.00	46.32	
	<u>750-7300-7037-0000</u>		VEHICLE MAINTENANCE VEHICLE MAINTENANCE		46.32	
<u>106681</u>	Invoice	12/11/2019	VEHICLE MAINTENANCE	0.00	170.50	
	<u>750-7600-7037-0000</u>		VEHICLE MAINTENANCE VEHICLE MAINTENANCE		170.50	
2009	O'REILLY AUTO PARTS	12/12/2019	Regular	0.00	35.74	104215
<b>Payable #</b>	<b>Payable Type</b>	<b>Post Date</b>	<b>Payable Description</b>	<b>Discount Amount</b>	<b>Payable Amount</b>	
	<b>Account Number</b>		<b>Account Name</b>		<b>Distribution Amount</b>	
<u>2678-225799</u>	Invoice	12/11/2019	VEHICLE MAINTENANCE	0.00	35.74	
	<u>100-3100-7037-0000</u>		VEHICLE MAINTENANCE VEHICLE MAINTENANCE		35.74	
2026	PACIFIC ALARM SERVICE	12/12/2019	Regular	0.00	712.80	104216
<b>Payable #</b>	<b>Payable Type</b>	<b>Post Date</b>	<b>Payable Description</b>	<b>Discount Amount</b>	<b>Payable Amount</b>	
	<b>Account Number</b>		<b>Account Name</b>		<b>Distribution Amount</b>	
<u>R 151794</u>	Invoice	12/11/2019	SECURITY SERVICES	0.00	60.25	
	<u>100-6000-7087-6026</u>		SECURITY- CITY HALL BLD SECURITY SERVICES		60.25	
<u>R 151785</u>	Invoice	12/11/2019	SECURITY SERVICES	0.00	179.55	
	<u>700-4050-7087-007A</u>		SECURITY SERVICES SECURITY SERVICES		179.55	
<u>R 151787</u>	Invoice	12/11/2019	SECURITY SERVICES	0.00	163.50	
	<u>700-4050-7087-005X</u>		SECURITY SERVICES SECURITY SERVICES		163.50	
<u>R 151788</u>	Invoice	12/11/2019	SECURITY SERVICES	0.00	113.25	
	<u>100-6000-7087-6040</u>		SECURITY - POLICE DEPT SECURITY SERVICES		113.25	
<u>R 151789</u>	Invoice	12/11/2019	SECURITY SERVICES	0.00	58.25	
	<u>100-6000-7087-6040</u>		SECURITY - POLICE DEPT SECURITY SERVICES		58.25	
<u>R 151792</u>	Invoice	12/11/2019	SECURITY SERVICES	0.00	138.00	
	<u>700-4050-7087-005X</u>		SECURITY SERVICES SECURITY SERVICES		138.00	
2051	PAYCHEX HUMAN RESOURCES SERVICES	12/12/2019	Regular	0.00	700.00	104217
<b>Payable #</b>	<b>Payable Type</b>	<b>Post Date</b>	<b>Payable Description</b>	<b>Discount Amount</b>	<b>Payable Amount</b>	
	<b>Account Number</b>		<b>Account Name</b>		<b>Distribution Amount</b>	
<u>9949708 12/02/1</u>	Invoice	12/11/2019	TIMECLOCK CHARGES	0.00	700.00	
	<u>100-1240-7068-0000</u>		CONTRACTUAL SERVICES TIMECLOCK CHARGES		350.00	
	<u>700-4050-7068-0000</u>		CONTRACTUAL SERVICES TIMECLOCK CHARGES		70.00	
	<u>750-7000-7068-0000</u>		CONTRACTUAL SERVICES TIMECLOCK CHARGES		19.00	
	<u>750-7100-7068-0000</u>		CONTRACTUAL SERVICES TIMECLOCK CHARGES		7.00	
	<u>750-7200-7068-0000</u>		CONTRACTUAL SERVICES TIMECLOCK CHARGES		91.00	
	<u>750-7300-7068-0000</u>		CONTRACTUAL SERVICES TIMECLOCK CHARGES		140.00	
	<u>750-7400-7068-0000</u>		CONTRACTUAL EXPENSES TIMECLOCK CHARGES		9.00	
	<u>750-7600-7068-0000</u>		CONTRACTUAL SERVICES TIMECLOCK CHARGES		14.00	
2072	POLYDYNE, INC.	12/12/2019	Regular	0.00	5,745.57	104218

Check Report

Date Range: 12/06/2019 - 12/31/2019

2.

Vendor Number	Vendor Name	Payment Date	Payment Type	Discount Amount	Payment Amount	Num
Payable #	Payable Type	Post Date	Payable Description	Discount Amount	Payable Amount	
	Account Number	Account Name	Item Description	Distribution Amount		
1407853	Invoice	12/12/2019	CHEMICALS & SUPPLIES	0.00	5,745.57	
	700-4050-7070-0000	SPECIAL DEPT SUPPLIES	CHEMICALS & SUPPLIES		5,745.57	
2074	PRE-PAID LEGAL SERVICES INC	12/12/2019	Regular	0.00	737.25	104219
Payable #	Payable Type	Post Date	Payable Description	Discount Amount	Payable Amount	
	Account Number	Account Name	Item Description	Distribution Amount		
PD 11/22/19-12/	Invoice	12/11/2019	OPTIONAL EMPLOYEE SERVICES	0.00	737.25	
	100-0000-2045-0000	PRE PAID LEGAL	OPTIONAL EMPLOYEE SERVICES		737.32	
	100-0000-4825-0000	MISCELLANEOUS REVENU	OPTIONAL EMPLOYEE SERVICES		-0.07	
3652	PRUDENTIAL OVERALL SUPPLY	12/12/2019	Regular	0.00	206.25	104220
Payable #	Payable Type	Post Date	Payable Description	Discount Amount	Payable Amount	
	Account Number	Account Name	Item Description	Distribution Amount		
22888372	Invoice	12/12/2019	Prudential Uniforms	0.00	68.75	
	100-3250-7065-0000	UNIFORMS	UNIFORM MAINTENANCE		68.75	
22895542	Invoice	12/12/2019	Prudential Uniforms	0.00	68.75	
	100-3250-7065-0000	UNIFORMS	UNIFORM MAINTENANCE		68.75	
22899075	Invoice	12/12/2019	Prudential Uniforms	0.00	68.75	
	100-3250-7065-0000	UNIFORMS	UNIFORM MAINTENANCE		68.75	
2104	RAMONA HUMANE SOCIETY INC	12/12/2019	Regular	0.00	3,972.26	104221
Payable #	Payable Type	Post Date	Payable Description	Discount Amount	Payable Amount	
	Account Number	Account Name	Item Description	Distribution Amount		
COB11302 11/30	Invoice	12/12/2019	Ramona Humane Society - Sheltering Serv	0.00	3,972.26	
	100-2000-7068-0000	CONTRACTUAL SERVICES	Ramona Humane Society - Shelt		3,972.26	
2289	SIMPLIFILE	12/12/2019	Regular	0.00	687.00	104222
Payable #	Payable Type	Post Date	Payable Description	Discount Amount	Payable Amount	
	Account Number	Account Name	Item Description	Distribution Amount		
CATWAO-113020	Invoice	12/11/2019	PROFESSIONAL SERVICES	0.00	687.00	
	100-1200-7068-0000	CONTRACTUAL SERVICES	PROFESSIONAL SERVICES		593.00	
	100-3100-7068-0000	CONTRACTUAL SERVICES	PROFESSIONAL SERVICES		94.00	
2311	SOUTHERN CALIFORNIA EDISON	12/12/2019	Regular	0.00	20,856.99	104223
Payable #	Payable Type	Post Date	Payable Description	Discount Amount	Payable Amount	
	Account Number	Account Name	Item Description	Distribution Amount		
12/11/19	Invoice	12/11/2019	ELECTRIC UTILITY	0.00	20,856.99	
	100-3250-7010-0000	UTILITIES	ELECTRIC UTILITY		10,951.61	
	100-3250-7010-003X	UTILITIES (IA 3)	ELECTRIC UTILITY		2,441.22	
	100-3250-7010-006B	UTILITIES (IA 6B)	ELECTRIC UTILITY		1,827.41	
	100-3250-7010-007A	UTILITIES (IA 7A)	ELECTRIC UTILITY		10.25	
	100-3250-7010-007B	UTILITIES (IA 7B)	ELECTRIC UTILITY		74.61	
	100-3250-7010-008A	UTILITIES (IA 8A)	ELECTRIC UTILITY		399.52	
	100-3250-7010-008C	UTILITIES (IA 8C)	ELECTRIC UTILITY		567.07	
	100-3250-7010-011A	UTILITIES (IA 11A)	ELECTRIC UTILITY		167.80	
	100-3250-7010-014B	UTILITIES (IA 14B)	ELECTRIC UTILITY		33.36	
	100-3250-7010-014X	UTILITIES (IA 14)	ELECTRIC UTILITY		1,441.46	
	100-3250-7010-018X	UTILITIES (IA 18)	ELECTRIC UTILITY		141.42	
	100-3250-7010-019C	UTILITIES (IA 19C)	ELECTRIC UTILITY		2,178.44	
	100-3250-7010-06A1	UTILITIES (IA 6A1)	ELECTRIC UTILITY		622.82	
2378	SYMBOL ARTS	12/12/2019	Regular	0.00	694.25	104224
Payable #	Payable Type	Post Date	Payable Description	Discount Amount	Payable Amount	
	Account Number	Account Name	Item Description	Distribution Amount		
0343971-IN	Invoice	12/11/2019	ADVERTISING	0.00	694.25	
	100-1200-7020-0000	ADVERTISING	ADVERTISING		694.25	
2395	TERMINIX COMMERCIAL	12/12/2019	Regular	0.00	125.00	104225



Check Report

Date Range: 12/06/2019 - 12/13/2019

2.

Vendor Number	Vendor Name	Payment Date	Payment Type	Discount Amount	Payment Amount	NU
Payable #	Payable Type	Post Date	Payable Description	Discount Amount	Payable Amount	
	Account Number	Account Name	Item Description	Distribution Amount		
591284488	Invoice	12/11/2019	BUILDING MAINTENANCE	0.00	45.00	
	750-7300-7085-0000		BUILDING SUPPLIES/MAI		45.00	
391646525	Invoice	12/11/2019	BUILDING MAINTENANCE	0.00	80.00	
	100-6000-7035-6040		BLDG MAINT - POLICE DE		80.00	
2399	TETRA TECH INC	12/12/2019	Regular	0.00	1,225.00	104226
Payable #	Payable Type	Post Date	Payable Description	Discount Amount	Payable Amount	
	Account Number	Account Name	Item Description	Distribution Amount		
51514723	Invoice	12/12/2019	DESIGN & GEOTECH FOR SENECA SPRING	0.00	1,225.00	
	710-0000-7068-0000		CONTRACTUAL SERVICE		1,225.00	
2407	THE GAS COMPANY	12/12/2019	Regular	0.00	434.83	104227
Payable #	Payable Type	Post Date	Payable Description	Discount Amount	Payable Amount	
	Account Number	Account Name	Item Description	Distribution Amount		
03822937417 12/	Invoice	12/11/2019	GAS UTILITY	0.00	91.36	
	100-6000-7010-6041		UTILITIES - POLICE ANNEX		91.36	
05789544425 12/	Invoice	12/11/2019	GAS UTILITY	0.00	343.47	
	100-6000-7010-6045		UTILITIES - COMMUNITY		343.47	
2416	THE PRESS-ENTERPRISE	12/12/2019	Regular	0.00	215.40	104228
Payable #	Payable Type	Post Date	Payable Description	Discount Amount	Payable Amount	
	Account Number	Account Name	Item Description	Distribution Amount		
0011333341	Invoice	12/11/2019	ADVERTISING	0.00	36.00	
	100-1150-7066-0000		TRAVEL, EDUCATION, TRA		36.00	
0011333394	Invoice	12/11/2019	ADVERTISING	0.00	179.40	
	710-0000-7068-0000		CONTRACTUAL SERVICE		179.40	
3866	TIM GODSEY	12/12/2019	Regular	0.00	161.56	104229
Payable #	Payable Type	Post Date	Payable Description	Discount Amount	Payable Amount	
	Account Number	Account Name	Item Description	Distribution Amount		
05-005036-02	Invoice	12/11/2019	REIMBURSE CREDIT ON ACCOUNT	0.00	161.56	
	100-0000-1400-0000		A/R - UTILITIES		161.56	
2435	TLMA ADMINISTRATION COUNTY OF RIV	12/12/2019	Regular	0.00	505.45	104230
Payable #	Payable Type	Post Date	Payable Description	Discount Amount	Payable Amount	
	Account Number	Account Name	Item Description	Distribution Amount		
TL0000014981	Invoice	12/12/2019	SHARED TRAFFIC SIGNALS WITH RIVERSID	0.00	505.45	
	100-3250-7068-0000		CONTRACTUAL SERVICES		505.45	
2457	TYLER WORKS - TECHNOLOGIES	12/12/2019	Regular	0.00	50.00	104231
Payable #	Payable Type	Post Date	Payable Description	Discount Amount	Payable Amount	
	Account Number	Account Name	Item Description	Distribution Amount		
025-279129	Invoice	12/11/2019	MONTHLY FEE TO SUPPORT AND HOST W	0.00	50.00	
	100-1230-7071-0000		SOFTWARE		50.00	
2461	UNDERGROUND SERVICE ALERT	12/12/2019	Regular	0.00	173.10	104232
Payable #	Payable Type	Post Date	Payable Description	Discount Amount	Payable Amount	
	Account Number	Account Name	Item Description	Distribution Amount		
1120190050	Invoice	12/12/2019	DIG ALERT - SEWER	0.00	76.00	
	700-4050-7068-0000		CONTRACTUAL SERVICES		76.00	
18DSBFE6127	Invoice	12/12/2019	DIG ALERT - SEWER	0.00	97.10	
	700-4050-7063-0000		CONTRACTUAL SERVICES		97.10	
2484	VERIZON	12/12/2019	Regular	0.00	4,949.52	104233

Check Report

Date Range: 12/06/2019 - 12/13/2019

2.

Vendor Number	Vendor Name	Payment Date	Payment Type	Discount Amount	Payment Amount	Num
Payable #	Payable Type	Post Date	Payable Description	Discount Amount	Payable Amount	
	Account Number	Account Name	Item Description	Distribution Amount		
9843018359	Invoice	12/11/2019	PHONE UTILITY - CELL PHONES	0.00	4,151.31	
	<u>100-1230-7015-0000</u>	TELEPHONE	PHONE UTILITY - CELL PHONES		3,705.31	
	<u>750-7000-7015-0000</u>	TELEPHONE	PHONE UTILITY - CELL PHONES		446.00	
9843018360	Invoice	12/11/2019	PHONE UTILITY - TRANSIT TABLETS	0.00	798.21	
	<u>750-7200-7015-0000</u>	TELEPHONE	PHONE UTILITY - TRANSIT TABLE		798.21	
2518	VULCAN MATERIALS	12/12/2019	Regular	0.00	2,173.81	104234
Payable #	Payable Type	Post Date	Payable Description	Discount Amount	Payable Amount	
	Account Number	Account Name	Item Description	Distribution Amount		
72401311	Invoice	12/12/2019	ASPHALT & SUPPLIES	0.00	612.16	
	<u>100-3250-7070-0000</u>	SPECIAL DEPT SUPPLIES	ASPHALT & SUPPLIES		612.16	
72401312	Invoice	12/12/2019	ASPHALT & SUPPLIES	0.00	369.27	
	<u>100-3250-7070-0000</u>	SPECIAL DEPT SUPPLIES	ASPHALT & SUPPLIES		369.27	
72413319	Invoice	12/12/2019	ASPHALT & SUPPLIES	0.00	372.19	
	<u>100-3250-7070-0000</u>	SPECIAL DEPT SUPPLIES	ASPHALT & SUPPLIES		372.19	
72414893	Invoice	12/12/2019	ASPHALT & SUPPLIES	0.00	368.54	
	<u>100-3250-7070-0000</u>	SPECIAL DEPT SUPPLIES	ASPHALT & SUPPLIES		368.54	
72421063	Invoice	12/12/2019	ASPHALT & SUPPLIES	0.00	372.19	
	<u>100-3250-7070-0000</u>	SPECIAL DEPT SUPPLIES	ASPHALT & SUPPLIES		372.19	
72424250	Invoice	12/12/2019	ASPHALT & SUPPLIES	0.00	79.46	
	<u>100-3250-7070-0000</u>	SPECIAL DEPT SUPPLIES	ASPHALT & SUPPLIES		79.46	
3422	WAXIE SANITARY SUPPLY	12/12/2019	Regular	0.00	1,051.35	104235
Payable #	Payable Type	Post Date	Payable Description	Discount Amount	Payable Amount	
	Account Number	Account Name	Item Description	Distribution Amount		
78701563	Invoice	12/11/2019	BULDING SUPPLIES	0.00	202.01	
	<u>100-6000-7085-6032</u>	BLDG MAINT- CITY HALL B	BUILDING SUPPLIES		20.20	
	<u>100-6000-7085-6040</u>	BLDG MAINT - POLICE DE	BUILDING SUPPLIES		161.61	
	<u>100-6000-7085-6041</u>	BLDG MAINT - POLICE AN	BUILDING SUPPLIES		20.20	
78704876	Invoice	12/11/2019	BUILDING SUPPLIES	0.00	849.34	
	<u>100-6000-7085-6025</u>	BLDG MAINT - CITY HALL	BUILDING SUPPLIES		849.34	
2556	XYLEM WATER SOLUTIONS, INC	12/12/2019	Regular	0.00	5,973.30	104236
Payable #	Payable Type	Post Date	Payable Description	Discount Amount	Payable Amount	
	Account Number	Account Name	Item Description	Distribution Amount		
3556A97746	Invoice	12/12/2019	RAS PUMP #5 AT WWTP	0.00	5,973.30	
	<u>700-4050-7090-0000</u>	EQUIPMENT SUPPLIES/M	REPAIR RAS PUMP #5 AT WWTP		5,973.30	
2946	Z & K CONSULTANTS, INC.	12/12/2019	Regular	0.00	6,160.00	104237

Check Report

Date Range: 12/06/2019 - 12/13/2019

Vendor Number Payable #	Vendor Name Payable Type Account Number	Post Date	Payment Date Payable Description Account Name	Payment Type Item Description	Discount Amount Discount Amount	Payment Amount Payable Amount Distribution Amount	Num
103 11/01/19-11	Invoice 710-0000-7068-0000	12/12/2019	PROFESSIONAL ENGINEERING SERVICES	PROFESSIONAL ENGINEERING S	0.00	6,160.00	2.

Bank Code APBNK Summary

Payment Type	Payable Count	Payment Count	Discount	Payment
Regular Checks	162	74	0.00	385,664.37
Manual Checks	0	0	0.00	0.00
Voided Checks	0	1	0.00	0.00
Bank Drafts	0	0	0.00	0.00
EFT's	2	2	0.00	9,206.97
	<b>164</b>	<b>77</b>	<b>0.00</b>	<b>394,871.34</b>

### All Bank Codes Check Summary

Payment Type	Payable Count	Payment Count	Discount	Payment
Regular Checks	162	74	0.00	385,664.37
Manual Checks	0	0	0.00	0.00
Voided Checks	0	1	0.00	0.00
Bank Drafts	0	0	0.00	0.00
EFT's	2	2	0.00	9,206.97
	<b>164</b>	<b>77</b>	<b>0.00</b>	<b>394,871.34</b>

### Fund Summary

Fund	Name	Period	Amount
999	POOLED CASH	12/2019	394,871.34
			<b>394,871.34</b>

**Item Attachment Documents:****3. Approval of Minutes**

Minutes of 11.21.19 Workshop

Minutes of 12.03.19

Minutes of 12.19.17 Special Meeting and Workshop



**MINUTES**  
**City Council Meeting**  
**Thursday, November 21, 2019**  
**Council Chambers**  
**550 E 6th St. Beaumont, Ca**  
**Workshop Session: 6:00 PM**

**WORKSHOP SESSION**

**CALL TO ORDER at 6:05 p.m.**

**Present:** Mayor Martinez, Mayor Pro Tem Santos, Council Member Carroll, Council Member Lara, and Council Member White

Action on any requests for excused absence: **None**

Pledge of Allegiance

Approval/Adjustments to Agenda: **None**

Conflict of Interest Disclosure: **None**

**PUBLIC COMMENT PERIOD (ITEMS NOT ON THE AGENDA)**

*Any one person may address the City Council on any matter not on this agenda. If you wish to speak, please fill out a "Public Comment Form" provided at the back table and give it to the City Clerk. There is a three (3) minute time limit on public comments. There will be no sharing or passing of time to another person. State Law prohibits the City Council from discussing or taking actions brought up by your comments.*

**No speakers.**

**ACTION ITEMS**

*Approval of all Ordinances and Resolutions to be read by title only.*

1. Budget Workshop - Initiation of the 2020-21 Budget Building Process

Presentation of a survey that was conducted internally and the results. Also included the current financial condition and City Capital needs. Discussion by the Council of City services and concerns. Consensus to schedule future workshops to further discuss possible reduction, expansion or modification of City services as well as possible expanded or new revenues. Next workshop is scheduled for December 17, 2019 at 5:00 p.m.

**ADJOURNMENT**

**Adjournment of the City Council Workshop of November 21, 2019, at 7:43 p.m.**



The next regular meeting of the Beaumont City Council, Beaumont Financing Authority, the Beaumont Successor Agency (formerly RDA), the Beaumont Utility Authority, the Beaumont Parking Authority and the Beaumont Public Improvement Agency is scheduled for Tuesday, December 3, 2019, at 5:00 p.m. or thereafter as noted on the posted Agenda for Closed Session items in the City Council Board Room No. 5, followed by the regular meeting at 6:00 p.m. or thereafter as noted on the posted Agenda at City Hall.

Beaumont City Hall – Online [www.BeaumontCa.gov](http://www.BeaumontCa.gov)



**MINUTES**  
 City Council Meeting  
 Tuesday, December 3, 2019  
 Council Chambers  
 550 E 6th St. Beaumont, Ca  
 Closed Session: 5:00 PM  
 Regular Session: 6:00 PM

**CLOSED SESSION**

*A Closed Session of the City Council / Beaumont Financing Authority / Beaumont Utility Authority / Beaumont Successor Agency (formerly RDA)/Beaumont Parking Authority / Beaumont Public Improvement Authority may be held in accordance with state law which may include, but is not limited to, the following types of items: personnel matters, labor negotiations, security matters, providing instructions to real property negotiators and conference with legal counsel regarding pending litigation. Any public comment on Closed Session items will be taken prior to the Closed Session. Any required announcements or discussion of Closed Session items or actions following the Closed Session will be made in the City Council Chambers.*

**CALL TO ORDER at 5:02 p.m.**

Mayor Martinez, Mayor Pro Tem Santos, Council Member Carroll, Council Member Lara, and Council Member White

1. Public Comments Regarding Closed Session

**No speakers.**

2. Conference with Legal Counsel Regarding Pending Litigation — Pursuant to Government Code Section 54956.9(d)(1)and/or(2) and/or (3): Worker's Compensation Case No. COBT - 002935 and COBM - 0094

**No reportable action.**

3. Conference with Labor Negotiators - Pursuant to Government Code Section 54957.6 City Designated Representatives City Manager Todd Parton and Administrative Services Director Kari Mendoza. Employee Organizations:  
 Police Management  
 Managers/Professional/Technical as Individuals

**No reportable action.**

**Adjourn to Closed Session**

## REGULAR SESSION

### CALL TO ORDER at 6:04 p.m.

**Present:** Mayor Martinez, Mayor Pro Tem Santos, Council Member Carroll, Council Member Lara, and Council Member White

Report out from Closed Session: *see above*

Action on any Closed Session items: **None**

Action on any requests for excused absence: **None**

Pledge of Allegiance

Approval/Adjustments to Agenda: **None**

Conflict of Interest Disclosure: **None**

### ANNOUNCEMENTS/RECOGNITIONS/PROCLAMATIONS/CORRESPONDENCE

1. Introduction of New Police Employees

### PUBLIC COMMENT PERIOD (ITEMS NOT ON THE AGENDA)

*Any one person may address the City Council on any matter not on this agenda. If you wish to speak, please fill out a "Public Comment Form" provided at the back table and give it to the City Clerk. There is a three (3) minute time limit on public comments. There will be no sharing or passing of time to another person. State Law prohibits the City Council from discussing or taking actions brought up by your comments.*

*R. Berg - Asked for an update of a public records request.*

### COUNCIL REPORTS

- **Carroll** - Reported out from the Finance and Audit Meeting.
- **Lara** - Reported out from a WRCOG meeting, shared a positive comment from a resident regarding christmas lighting permits.
- **Martinez** - Reported out from an RCTC meeting, the City Thanksgiving dinner outreach program, and reported out from the RCA meeting.
- **Santos** - No report.
- **White** - No report.

2. Legislative Updates and Discussion

### ECONOMIC DEVELOPMENT UPDATE

Economic Development Committee Report Out and City Council Direction

### CITY TREASURER REPORT

Finance and Audit Committee report out.

### **CITY CLERK REPORT**

Gave a brief update on Mr. Berg's request.

### **CITY ATTORNEY REPORT**

No report.

### **CITY MANAGER REPORT**

Announced traffic signal improvements at 2nd Street and Commerce.

### **CONSENT CALENDAR**

*Items on the consent calendar are taken as one action item unless an item is pulled for further discussion here or at the end of action items.*

*Approval of all Ordinances and Resolutions to be read by title only.*

3. Ratification of Warrants
4. Approval of Minutes
5. Second Reading and Adoption of an Amendment to Table 17.03-3 Permitted Uses in Base Zone District and Addition of Chapter 17.18 Regarding Wireless Telecommunications Facilities
6. Approve the Second Reading of an Ordinance Repealing Chapter 13.20 of the Beaumont Municipal Code and Adopting by Reference in its Place Ordinance No. 8 of the Santa Ana Watershed Project Authority
7. Approval of Second Reading of "An Ordinance of the City Council of the City of Beaumont, California, Amending Section 8.12.240 of the Beaumont Municipal Code Regarding the Collection of Delinquent Solid Waste Handling Service Fees and Charges on The Tax Roll"
8. Second Reading of an Ordinance to Amend Chapter 15.20 of the Beaumont Municipal Code for the Adoption of the 2019 California Fire Code (California Code of Regulations Title 24, Part 9)
9. Second Reading of an Ordinance Amending Chapter 15 of the Beaumont Municipal Code for the Adoption of the 2019 California Building Standards Code (California Code of Regulations Title 24)
10. Performance Bond Acceptance and Security Agreement for Pardee Tract 37298-1 Street and Storm Drain Improvements

11. Performance Bond Acceptance and Security Agreements for San Gorgonio Village Street, Traffic Signal Improvements, and Survey Monumentation
12. Tentative Parcel Map No. 37660 TPM2019-0004, a Request to Subdivide Approximately 14.61 Acres into 7 Lots Ranging in Size from .97 Acres to 4.23 Acres for Finance and Conveyance Purposes, Located on the East and West Sides of Commerce Way Between 2nd and 1st Streets in the San Gorgonio Village Specific Plan
13. Final Approval of Parcel Map No. 37660 for SGV Beaumont, LLC Located in the San Gorgonio Village Specific Plan
14. Edward Byrne Memorial Justice Assistance Grant Program Fiscal Year 2019 Interlocal Agreement

**Moved by Council Member White  
Seconded by Mayor Martinez  
To approve the consent calendar.**

**Ayes:** Lara, Martinez, Carroll, White, and Santos  
**Approved by a unanimous vote.**

## **PUBLIC HEARINGS**

*Approval of all Ordinances and Resolutions to be read by title only*

15. Hold a Public Hearing and Consider an Amendment to Table 17.03-3 Permitted Uses in Base Zone District and Table 17.03-4 Permitted Uses in Overlay Zone Districts, Large Family Daycare

**Public Comment opened and closed at 6:36 p.m.**

**Moved by Council Member Lara  
Second by Council Member Carroll  
To approve Amendments to Table 17.03-3 Permitted Uses in  
Base Zone District and Table 17.03-4 Permitted Uses in  
Overlay Zone Districts for Large Family Daycares.**

**Ayes:** Lara, Martinez, Carroll, White, and Santos  
**Approved by a unanimous vote.**

16. Conduct a Public Hearing and Consider Development Agreement PLAN2019-0336 for a 2.89

Million Square Foot Industrial Business Park (Hidden Canyon Industrial Park); Located at the Western Terminus of Fourth Street, South of State Highway 60, East of Jack Rabbit Trail

**Public Comment opened 6:40 p.m.**

***B. McDonald*** - Gave a summary of the intentions for the property.

**Public Comment closed at 6:48 p.m.**

**Moved by Council Member Lara**

**Seconded by Council Member White**

**To approve Development Agreement PLAN2019-0336.**

**Ayes:** Lara, Martinez, Carroll, White, and Santos

**Approved by a unanimous vote.**

#### **ACTION ITEMS**

*Approval of all Ordinances and Resolutions to be read by title only.*

17. Consideration of First Amendment to Collection Services Agreement for the Provision of Residential and Commercial Garbage, Recyclable Materials and Organic Waste Collection Services between the City of Beaumont and Waste Management of the Inland Empire

**City Attorney John Pinkney recused himself on this item.**

**Moved by Council Member Lara**

**Seconded by Mayor Pro Tem Santos**

**To approve of the First Amendment to Collection Services Agreement for the provision of residential and commercial garbage, recyclable materials and organic waste collection services between the City of Beaumont and Waste Management of the Inland Empire.**

**Ayes:** Lara, Martinez, Carroll, White, and Santos

**Approved by a unanimous vote.**

18. Award of Contract for Employee Benefits Insurance Broker & Consulting Services

**Moved by Council Member Lara**

**Seconded by Council Member Carroll**

**To award a professional services agreement to Quote Frontier and authorize the Mayor to execute the agreement on**



**behalf of the City of Beaumont for three years with the option for two one-year extensions.**

**Ayes:** Lara, Martinez, Carroll, White, and Santos  
**Approved by a unanimous vote.**

19. Approve the Resolution Adopting by Reference the Pretreatment Program Enforcement Response Plan, Pretreatment Program Procedures and Pretreatment Program Policies of the Santa Ana Watershed Project Authority

**Moved by Mayor Martinez**  
**Seconded by Council Member Lara**  
**Waive the full reading and approve by title only, "A Resolution of the City Council of the City of Beaumont Adopting by Reference the Pretreatment Program Enforcement Response Plan, Pretreatment Program Policies and Pretreatment Program Policies of the Santa Ana Watershed Project Authority."**

**Ayes:** Lara, Martinez, Carroll, White, and Santos  
**Approved by a unanimous vote.**

20. Approve a Resolution Prohibiting the Provision of Wastewater Treatment Services Outside of the Corporate Boundaries of the City of Beaumont with Certain Exceptions

**Moved by Mike Lara**  
**Seconded by Nancy Carroll**  
**Waive the full reading and approve by title only, "A Resolution of the City Council of the City of Beaumont Prohibiting the Provision of Wastewater Treatment Services Outside of the Corporate Boundaries of the City of Beaumont with Certain Exceptions."**

**Ayes:** Lara, Martinez, Carroll, White, and Santos  
**Approved by a unanimous vote.**

21. Wastewater Treatment Plant Expansion/Renovation and Brine Pipeline Installation Project Status Update

**Moved by Council Member White  
Seconded by Council Member Lara  
To receive and file the project updates.**

**Ayes:** Lara, Martinez, Carroll, White, and Santos  
**Approved by a unanimous vote.**

22. Appointment of Mayor and Mayor Pro Tempore

**Moved by Mayor Martinez  
Seconded by Council Member Carroll  
To appoint Rey Santos as Mayor and  
To appoint Mike Lara as Mayor Pro Tempore.**

**Ayes:** Lara, Martinez, Carroll, White, and Santos  
**Approved by a unanimous vote.**

**FUTURE AGENDA ITEMS**

**ADJOURNMENT**

**Adjournment of the City Council of the December 3, 2019 Meeting at \_\_\_\_ p.m.**

The next regular meeting of the Beaumont City Council, Beaumont Financing Authority, the Beaumont Successor Agency (formerly RDA), the Beaumont Utility Authority, the Beaumont Parking Authority and the Beaumont Public Improvement Agency is scheduled for Tuesday, January 7, 2020, at 5:00 p.m. or thereafter as noted on the posted Agenda for Closed Session items in the City Council Board Room No. 5, followed by the regular meeting at 6:00 p.m. or thereafter as noted on the posted Agenda at City Hall.

Beaumont City Hall – Online [www.BeaumontCa.gov](http://www.BeaumontCa.gov)



**MINUTES**  
**City Council Meeting**  
**Tuesday, December 17, 2019**  
**Council Chambers**  
**550 E 6th St. Beaumont, Ca**  
**Closed Session: 5:30 PM**  
**Regular Session: 6:00 PM**

**CLOSED SESSION**

*A Closed Session of the City Council / Beaumont Financing Authority / Beaumont Utility Authority / Beaumont Successor Agency (formerly RDA)/Beaumont Parking Authority / Beaumont Public Improvement Authority may be held in accordance with state law which may include, but is not limited to, the following types of items: personnel matters, labor negotiations, security matters, providing instructions to real property negotiators and conference with legal counsel regarding pending litigation. Any public comment on Closed Session items will be taken prior to the Closed Session. Any required announcements or discussion of Closed Session items or actions following the Closed Session will be made in the City Council Chambers.*

**CALL TO ORDER 5:31 p.m.**

**Present:** Mayor Martinez, Mayor Pro Tem Santos, Council Member Lara, and Council Member White

Council Member Carroll was present at 5:48 p.m.

1. Public Comments Regarding Closed Session

**No speakers.**

2. Conference with Legal Counsel - Anticipated Litigation: Significant Exposure to Litigation Pursuant to Government Code Section 54956.9(d)(2) - One Claim: James Huss Jr., dba West SWPPP

**Motion by Council Member Lara**

**Second by Council Member White**

**To deny the claim.**

**Approved by a 4-0 vote.**

**Absent: Council Member Carroll**

**Adjourn to Closed Session**

## REGULAR SESSION

### CALL TO ORDER at 6:09 p.m.

**Present:** Mayor Martinez, Mayor Pro Tem Santos, Council Member Carroll, Council Member Lara, and Council Member White

Report out from Closed Session: *see above*

Action on any Closed Session items:

Action on any requests for excused absence: **None**

Pledge of Allegiance

Approval/Adjustments to Agenda: **None**

Conflict of Interest Disclosure: **None**

### PUBLIC COMMENT PERIOD (ITEMS NOT ON THE AGENDA)

*Any one person may address the City Council on any matter not on this agenda. If you wish to speak, please fill out a "Public Comment Form" provided at the back table and give it to the City Clerk. There is a three (3) minute time limit on public comments. There will be no sharing or passing of time to another person. State Law prohibits the City Council from discussing or taking actions brought up by your comments.*

**No speakers.**

### ACTION ITEMS

*Approval of all Ordinances and Resolutions to be read by title only.*

1. Approval of City Attorney Invoices for Month of November 2019

**Moved by Council Member White**

**Seconded by Council Member Lara**

**To approve invoices in the amount of \$106,148.99.**

**Ayes:** Mike Lara, Julio Martinez, Nancy Carroll, Lloyd White, and Rey Santos

**Approved by a unanimous vote.**

2. Discussion of Fiscal Year 2020-2021 Budget

*Discussion and input from Council on forecast models to bring forward to a future meeting.*

### ADJOURNMENT

**Adjournment of the City Council Special Meeting and Budget Workshop of December 17, 2019 at 8:01 p.m.**

The next regular meeting of the Beaumont City Council, Beaumont Financing Authority, the Beaumont Successor Agency (formerly RDA), the Beaumont Utility Authority, the Beaumont Parking Authority and the Beaumont Public Improvement Agency is scheduled for Tuesday, January 7, 2020, at 5:00 p.m. or thereafter as noted on the posted Agenda for Closed Session items in the City Council Board Room No. 5, followed by the regular meeting at 6:00 p.m. or thereafter as noted on the posted Agenda at City Hall.

Beaumont City Hall – Online [www.BeaumontCa.gov](http://www.BeaumontCa.gov)

**Item Attachment Documents:****4. Adopt an Amendment to Table 17.03-3 Permitted Uses in Base Zone District and Table 17.03-4 Permitted Uses in Overlay Zone Districts, Large Family Daycare**

## Recommended Action:

Waive the second full reading and approve by title only, "An Ordinance of the City of Beaumont Approving an Amendment and Addition to the City of Beaumont Municipal Code Pertaining to the Regulation of Large Family Daycares: Amending Table 17.03-3 'Permitted Uses for Base Zone Districts' and Table 17.03-4 Permitted Uses in Overlay Zone Districts."





## Staff Report

**TO:** Mayor, and City Council Members  
**FROM:** Christina Taylor, Community Development Director  
**DATE:** January 7, 2020  
**SUBJECT:** Adopt an Amendment to Table 17.03-3 Permitted Uses in Base Zone District and Table 17.03-4 Permitted Uses in Overlay Zone Districts, Large Family Daycare

### Background and Analysis:

The Municipal Code Chapter 17.03.120 of the City of Beaumont includes Table 17.03-3 for Permitted Uses in Base Zone Districts and Municipal Code chapter 17.03.150 includes Table 17.03-4 for Permitted Uses of Overlay Zone Districts. The purpose of these tables and the zoning code is to regulate uses throughout the City and ensure compatibility in and among zones.

The State of California legislature recently passed Senate Bill No. 234, taking effect January 1, 2020. This bill requires large family daycares to be treated as residential uses in residential zones and requires local jurisdictions to treat large family day cares the same as small family day cares. Small family daycares allow up to 6 children, are regulated by the State of California and do not require approvals by a local jurisdiction other than the Fire Department. Large family daycares allow up to 14 children and also require Fire Department clearance prior to operation. Currently, the Beaumont Municipal Code specifies conditional use permit approval by the Planning Commission for a large family day care to operate. As of January 1, 2020, Senate Bill No. 234 prohibits this requirement.

As a result of this legislation, staff has prepared an amendment to Title 17 Zoning, Tables 17.03-3 and 17.03-4. The proposed amendment removes the Conditional Use Permit (C) requirement and replaces it with Permitted (P) establishing large family day cares as a permitted use in all residential zones.

Table 17.03-3 Permitted Land Uses For Base Zone Districts									
	RC	PF	RR	RSF	RMF	CG	CC	M	CM
Daycare Centers, Large Family – 7 to 14 Children	N	N	C-P	C-P	C-P	N	N	N	N

Table 17.03-4 Permitted Land Uses For Overlay Zone Districts (continued)			
	6 <sup>th</sup> St Overlay	Beaumont Ave. Overlay	Urban Village Overlay
Daycare Centers, Large Family – 7 to 14 Children	C-P	C P	C P

On November 12, 2019, the City of Beaumont Planning Commission held a public hearing and forwarded a recommendation of approval of the proposed changes to the City Council. On December 3, 2019, Council held a public hearing and approved the first reading of the draft ordinance.

**Fiscal Impact:**

Cost of staff time to prepare the report and legal review approximately \$1,000.

**Recommended Action:**

Waive the second full reading and approve by title only, "An Ordinance of the City of Beaumont Approving an Amendment and Addition to the City of Beaumont Municipal Code Pertaining to the Regulation of Large Family Daycares: Amending Table 17.03-3 'Permitted Uses for Base Zone Districts' and Table 17.03-4 Permitted Uses in Overlay Zone Districts."

**Attachments:**

- A. Draft ordinance
- B. SB 234

ORDINANCE NO.

AN ORDINANCE OF THE CITY COUNCIL OF THE CITY OF BEAUMONT, CALIFORNIA AMENDING TABLE 17.03-3 "PERMITTED USES FOR BASE ZONE DISTRICTS" AND TABLE 17.03-4 "PERMITTED USES FOR OVERLAY ZONE DISTRICTS" WITHIN CHAPTER 17, "ZONING" OF THE BEAUMONT MUNICIPAL CODE

BE IT ORDAINED BY THE CITY COUNCIL OF THE CITY OF BEAUMONT, RIVERSIDE COUNTY, STATE OF CALIFORNIA AS FOLLOWS:

SECTION 1. CEQA. The City Council finds that the actions contemplated by this Ordinance are exempt from the California Environmental Quality Act ("CEQA") pursuant to 15061(b)(3). CEQA review is not required because there is no possibility that this Ordinance may have a significant effect upon the environment and the proposed text amendments constitute a minor alteration in a land use limitation under CEQA Guidelines Section 15305, and such a land use limitation is a permissible exercise of the City's zoning powers.

SECTION 2. Severability. The City Council hereby declares that if any provision, section, paragraph, sentence, or word of this Ordinance is rendered or declared to be invalid or unconstitutional by any final court action in a court of competent jurisdiction, or by reason of any preemptive legislation, such invalidity shall not affect the other provisions, sections, paragraphs, sentences, or words of this Ordinance, and to this end the provisions of this Ordinance are severable. The City Council declares that it would have adopted this Ordinance irrespective of the invalidity of any particular portion thereof and intends that the invalid portions should be severed and the balance of the Ordinance enforced.

SECTION 3. Prosecution of Prior Ordinances. Neither the adoption of this Ordinance nor the repeal of any other ordinance of this City shall in any manner affect the prosecution of any violation of any City ordinance or provision of the City of Beaumont Municipal Code, committed prior to the effective date hereof, nor be construed as a waiver of any penalty or the penal provisions applicable to any violation thereof.

SECTION 4. The City Council hereby amends Title 17, Table 17.03-3, entitled "Permitted Uses for Base Zone Districts" to the Beaumont Municipal Code, to modify Large Family Daycare to the table to read as follows.

Table 17.03-3 Permitted Land Uses For Base Zone Districts. Table with 10 columns (RC, PF, RR, RSF, RMF, CG, CC, M, CM) and 2 rows (headers and Daycare Centers, Large Family - 7 to 14 Children).

**SECTION 5.** The City Council hereby amends Title 17, Table 17.03-4, entitled “Permitted Uses for Overlay Zone Districts” to the Beaumont Municipal Code, to modify the table Large Family Daycares to read as follows.

<b>Table 17.03-4 Permitted Land Uses For Overlay Zone Districts (continued)</b>			
	<b>6<sup>th</sup> St Overlay</b>	<b>Beaumont Ave. Overlay</b>	<b>Urban Village Overlay</b>
Daycare Centers, Large Family – 7 to 14 Children	<u>GP</u>	<u>GP</u>	<u>GP</u>

**SECTION 6. Effective Date and Publication.** The Mayor shall sign and the City Clerk shall certify to the passage of this Ordinance and cause the same or a summary thereof to be published within 15 days after adoption in accordance with Government Code Section 36933. This Ordinance shall take effect 30 days after adoption in accordance with Government Code Section 36937.

NOW, THEREFORE, BE IT ORDAINED that the City Council of the City of Beaumont, California, approves an amendment to the City Code.

**INTRODUCED AND READ** for the first time and ordered posted at a regular meeting of the City Council of the City of Beaumont, California, held on the \_\_\_\_\_ day of \_\_\_\_\_, 2019, by the following roll call vote:

- AYES:
- NOES
- ABSENT
- ABSTAIN

**PASSED, APPROVED AND ADOPTED** at a regular meeting of the City Council of the City of Beaumont, California, held on the \_\_\_\_\_ day of \_\_\_\_\_, 2019.

- AYES:
- NOES:
- ABSENT:
- ABSTAIN:

\_\_\_\_\_  
Julio Martinez, Mayor

Attest: \_\_\_\_\_  
City Clerk

Approved as to form:

\_\_\_\_\_  
John O. Pinkney, City Attorney

**Senate Bill No. 234**

## CHAPTER 244

An act to amend Sections 1596.72, 1596.73, 1596.78, 1597.30, 1597.45, and 1597.54 of, to add Sections 1597.41, 1597.42, and 1597.455 to, to repeal Section 1597.47 of, and to repeal and add Sections 1597.40, 1597.46, and 1597.543 of, the Health and Safety Code, relating to family daycare homes.

[Approved by Governor September 5, 2019. Filed with Secretary of State September 5, 2019.]

## LEGISLATIVE COUNSEL'S DIGEST

SB 234, Skinner. Family daycare homes.

Under existing law, the California Child Day Care Facilities Act, the State Department of Social Services licenses and regulates family daycare homes. Under existing law, a small family daycare home, which may provide care for up to 8 children, is considered a residential use of property for purposes of all local ordinances. Existing law authorizes a city, county, or city and county to either classify a large family daycare home, which may provide care for up to 14 children, as residential use of the property or to provide a process for applying for a permit to use the property as a large family daycare home.

This bill would instead require a large family daycare home to be treated as a residential use of property for purposes of all local ordinances.

Existing law makes void every provision in a written instrument entered into relating to real property that purports to forbid or restrict the conveyance, encumbrance, leasing, or mortgaging of the real property for use or occupancy as a family daycare home for children and every restriction or prohibition in a written instrument as to the use or occupancy of the property as a family daycare home.

This bill would also make void an attempt to deny, restrict, or encumber the conveyance, leasing, or mortgaging of real property for use or occupancy as a family daycare home and a restriction related to the use or occupancy of the property as a family daycare home. The bill would prohibit a property owner or manager from refusing to sell or rent, or refusing to negotiate for the sale or rental of, or otherwise making unavailable or denying, a detached single-family dwelling, a townhouse, a dwelling unit within a dwelling, or a dwelling unit within a covered multifamily dwelling in which the underlying zoning allows for residential use to a person because that person is a family daycare provider. The bill would require the department to notify applicants for family daycare home licenses that specified housing discrimination remedies are available to a family daycare home provider, family daycare home provider applicant, or person who is claiming that any of these protections have been denied.

Existing law prohibits a local jurisdiction from imposing a business license, fee, or tax for the privilege of operating a small family daycare home.

This bill would extend that prohibition to large family daycare homes.

Existing law requires the State Fire Marshal to adopt building standards and regulations relating to the fire and life safety systems in family daycare provider homes.

This bill would require the State Fire Marshal to update those regulations in the next regulation adoption cycle, and every 3 years thereafter to conform to changes in these provisions. The bill would also require the State Fire Marshal to issue guidance on implementing the provisions prior to the publication of regulations, but not later than January 1, 2021, and would authorize guidance to be issued annually thereafter in years when the specified regulations are not updated.

The bill would also make technical and conforming changes.

*The people of the State of California do enact as follows:*

SECTION 1. Section 1596.72 of the Health and Safety Code is amended to read:

1596.72. The Legislature finds all of the following:

(a) That child daycare facilities can contribute positively to a child's emotional, cognitive, and educational development.

(b) That it is the intent of this state to provide a comprehensive, quality system for licensing child daycare facilities to ensure a quality childcare environment.

(c) That this system of licensure requires a special understanding of the unique characteristics and needs of the children served by child daycare facilities.

(d) That it is the intent of the Legislature to establish within the State Department of Social Services an organizational structure to separate licensing of child daycare facilities from those facility types administered under Chapter 3 (commencing with Section 1500).

(e) That good quality childcare services are an essential service for working parents.

(f) California has a tremendous shortage of regulated childcare, and only a small fraction of families who need childcare have it. Parents should be able to support their families without having to sacrifice their child's well-being.

(g) With childcare, families have more options for jobs and education to improve their prospects. Good, affordable childcare gives children a strong start and creates opportunities for families and communities.

SEC. 2. Section 1596.73 of the Health and Safety Code is amended to read:

1596.73. The purposes of this act are to:



- (a) Streamline the administration of childcare licensing and thereby increase the efficiency and effectiveness of this system.
- (b) Encourage the development of licensing staff with knowledge and understanding of children and childcare needs.
- (c) Provide providers of childcare with technical assistance about licensing requirements.
- (d) Enhance consumer awareness of licensing requirements and the benefits of licensed childcare.
- (e) Recognize that affordable, quality licensed childcare is critical to the well-being of parents and children in this state.
- (f) Promote the development and expansion of regulated childcare.

SEC. 3. Section 1596.78 of the Health and Safety Code is amended to read:

1596.78. (a) “Family daycare home” means a facility that regularly provides care, protection, and supervision for 14 or fewer children, in the provider’s own home, for periods of less than 24 hours per day, while the parents or guardians are away, and is either a large family daycare home or a small family daycare home.

(b) “Large family daycare home” means a facility that provides care, protection, and supervision for 7 to 14 children, inclusive, including children under 10 years of age who reside at the home, as set forth in Section 1597.465 and as defined in regulations.

(c) “Small family daycare home” means a facility that provides care, protection, and supervision for eight or fewer children, including children under 10 years of age who reside at the home, as set forth in Section 1597.44 and as defined in regulations.

(d) A small family daycare home or large family daycare home includes a detached single-family dwelling, a townhouse, a dwelling unit within a dwelling, or a dwelling unit within a covered multifamily dwelling in which the underlying zoning allows for residential uses. A small family daycare home or large family daycare home is where the daycare provider resides, and includes a dwelling or a dwelling unit that is rented, leased, or owned.

SEC. 4. Section 1597.30 of the Health and Safety Code is amended to read:

1597.30. The Legislature finds and declares all of the following:

- (a) The Legislature has a responsibility to ensure the health and safety of children in family homes that provide daycare.
- (b) There is an extreme shortage of regulated family daycare homes in California, and the number has decreased significantly since 2008.
- (c) There continues to be a growing need for child daycare facilities due to the increased number of working parents. Parents need childcare so they can work and attend school, and so their children can thrive.
- (d) Many parents prefer childcare located in their neighborhoods in family homes.
- (e) There should be a variety of childcare settings, including regulated family daycare homes, as suitable choices for parents.

(f) The licensing program to be operated by the state should be cost effective, streamlined, and simple to administer in order to ensure adequate care for children placed in family daycare homes, while not placing undue burdens on the providers.

(g) The state should maintain an efficient program of regulating family daycare homes that ensures the provision of adequate protection, supervision, and guidance to children in their homes.

(h) The state has a responsibility to promote the development and expansion of regulated family daycare homes to care for children in residential settings.

SEC. 5. Section 1597.40 of the Health and Safety Code is repealed.

SEC. 6. Section 1597.40 is added to the Health and Safety Code, to read:

1597.40. (a) It is the intent of the Legislature that family daycare homes for children should be situated in normal residential surroundings so as to give children the home environment that is conducive to healthy and safe development. It is the public policy of this state to provide children in a family daycare home the same home environment as provided in a traditional home setting.

(b) The Legislature declares this policy to be of statewide concern with the purpose of occupying the field. This act, the state building code, and the fire code, and regulations promulgated pursuant to those provisions, shall preempt local laws, regulations, and rules governing the use and occupancy of family daycare homes. Local laws, regulations, or rules shall not directly or indirectly prohibit or restrict the use of a facility as a family daycare home, including, but not limited to, precluding the operation of a family daycare home.

SEC. 7. Section 1597.41 is added to the Health and Safety Code, to read:

1597.41. (a) Every provision in a written instrument relating to real property that purports to restrict the conveyance, encumbrance, leasing, or mortgaging of the real property for use or occupancy as a family daycare home is void, and every restriction in that written instrument as to the use or occupancy of the property as a family daycare home is void.

(b) An attempt to deny, restrict, or encumber the conveyance, leasing, or mortgaging of real property for use or occupancy as a family daycare home is void. A restriction related to the use or occupancy of the property as a family daycare home is void. A property owner or manager shall not refuse to sell or rent, or refuse to negotiate for the sale or rental of, or otherwise make unavailable or deny, a detached single-family dwelling, a townhouse, a dwelling unit within a dwelling, or a dwelling unit within a covered multifamily dwelling in which the underlying zoning allows for residential use to a person because that person is a family daycare provider.

(c) Except as provided in subdivision (d), a restriction, whether by way of covenant, contract, condition upon use or occupancy, or by transfer of title to real property, that restricts directly or indirectly limits the acquisition, use, or occupancy of a detached single-family dwelling, a townhouse, a dwelling unit within a dwelling, or a dwelling unit within a covered

multifamily dwelling in which the underlying zoning allows for residential use as a family daycare home is void.

(d) (1) A prospective family daycare home provider who resides in a rental property shall provide 30 days' written notice to the landlord or owner of the rental property prior to the commencement of operation of the family daycare home.

(2) A family daycare home provider who has relocated an existing licensed family daycare home program to a rental property on or after January 1, 1997, may provide less than 30 days' written notice when the department approves the operation of the new location of the family daycare home in less than 30 days, or the home is licensed in less than 30 days, so that service to the children served in the former location not be interrupted.

(3) A family daycare home provider in operation on rental or leased property as of January 1, 1997, shall notify the landlord or property owner in writing at the time of the annual license fee renewal, or by March 31, 1997, whichever occurs later.

(4) Notwithstanding any other law, upon commencement of, or knowledge of, the operation of a family daycare home on an individual's property, the landlord or property owner may require the family daycare home provider to pay an increased security deposit for operation of the family daycare home. The increase in deposit may be required notwithstanding that a lesser amount is required of tenants who do not operate family daycare homes. The total security deposit charged shall not exceed the maximum allowable under existing law.

(5) Section 1596.890 does not apply to this subdivision.

(e) During the license application process for a small or large family daycare home, the department shall notify the applicant that the remedies and procedures in Article 2 (commencing with Section 12980) of Chapter 7 of Part 2.8 of Division 3 of Title 2 of the Government Code relating to fair housing are available to family daycare home providers, family daycare home provider applicants, and individuals who claim that any of the protections provided by this section or Section 1597.40, 1597.42, 1597.43, 1597.45, 1597.455, or 1597.46 have been denied.

(f) For the purpose of this section, "restriction" means a restriction imposed orally, in writing, or by conduct and includes prohibition.

(g) This section does not alter the existing rights of landlords and tenants with respect to addressing and resolving issues related to noise, lease violations, nuisances, or conflicts between landlords and tenants.

SEC. 8. Section 1597.42 is added to the Health and Safety Code, to read:

1597.42. The use of a home as a family daycare home, operated under the standards of state law, in a residentially zoned area shall be considered a residential use of property for the purposes of all local ordinances, regulations, and rules, and shall not fundamentally alter the nature of the underlying residential use.

SEC. 9. Section 1597.45 of the Health and Safety Code is amended to read:

1597.45. (a) The use of a home as a small or large family daycare home shall be considered a residential use of property and a use by right for the purposes of all local ordinances, including, but not limited to, zoning ordinances.

(b) A local jurisdiction shall not impose a business license, fee, or tax for the privilege of operating a small or large family daycare home.

(c) Use of a home as a small or large family daycare home shall not constitute a change of occupancy for purposes of Part 1.5 (commencing with Section 17910) of Division 13 (State Housing Law) or for purposes of local building codes.

(d) A small or large family daycare home shall not be subject to the provisions of Division 13 (commencing with Section 21000) of the Public Resources Code.

(e) The provisions of this chapter do not preclude a city, county, or other local public entity from placing restrictions on building heights, setback, or lot dimensions of a family daycare home, as long as those restrictions are identical to those applied to all other residences with the same zoning designation as the family daycare home. This chapter does not preclude a local ordinance that deals with health and safety, building standards, environmental impact standards, or any other matter within the jurisdiction of a local public entity, as long as the local ordinance is identical to those applied to all other residences with the same zoning designation as the family daycare home. This chapter also does not prohibit or restrict the abatement of nuisances by a city, county, or city and county. However, the ordinance or nuisance abatement shall not distinguish family daycare homes from other homes with the same zoning designation, except as otherwise provided in this chapter.

(f) For purposes of this chapter, “small family daycare home or large family daycare home” includes a detached single-family dwelling, a townhouse, a dwelling unit within a dwelling, or a dwelling unit within a covered multifamily dwelling in which the underlying zoning allows for residential uses. A small family daycare home or large family daycare home is where the family daycare provider resides, and includes a dwelling or dwelling unit that is rented, leased, or owned.

SEC. 10. Section 1597.455 is added to the Health and Safety Code, to read:

1597.455. (a) A small family daycare home shall not be subject to Article 1 (commencing with Section 13100) or Article 2 (commencing with Section 13140) of Chapter 1 of Part 2 of Division 12, except that a small family daycare home shall contain a fire extinguisher and smoke detector device that meet standards established by the State Fire Marshal.

(b) A small family daycare home for children shall have one or more carbon monoxide detectors in the facility that meet the standards established in Chapter 8 (commencing with Section 13260) of Part 2 of Division 12. The department shall account for the presence of these detectors during inspections.

SEC. 11. Section 1597.46 of the Health and Safety Code is repealed.

SEC. 12. Section 1597.46 is added to the Health and Safety Code, to read:

1597.46. (a) A large family daycare home shall abide by all standards, in addition to the requirements of the State Uniform Building Standards Code, that are specifically designed to promote fire and life safety in large family daycare homes. The State Fire Marshal shall adopt separate building standards specifically relating to the subject of fire and life safety in family daycare homes, which shall be published in Title 24 of the California Code of Regulations. These standards shall apply uniformly throughout the state and shall include, but not be limited to, all of the following:

(1) The requirement that a large family daycare home contain a fire extinguisher or smoke detector device, or both, that meets childcare standards established by the State Fire Marshal.

(2) Specification as to the number of required exits from the home.

(3) Specification as to the floor or floors on which childcare may be provided and the number of required exits on each floor.

(b) A large family daycare home for children shall have one or more carbon monoxide detectors in the facility that meet the standards established in Chapter 8 (commencing with Section 13260) of Part 2 of Division 12. The department shall account for the presence of these detectors during inspections.

(c) Enforcement of this section shall be in accordance with Sections 13145 and 13146. A city, county, city and county, or district shall not adopt or enforce a building ordinance or local rule or regulation relating to the subject of fire and life safety in large family daycare homes that is inconsistent with those standards adopted by the State Fire Marshal, except to the extent the building ordinance or local rule or regulation applies to all residences with the same zoning designation in which childcare is provided.

SEC. 13. Section 1597.47 of the Health and Safety Code is repealed.

SEC. 14. Section 1597.54 of the Health and Safety Code is amended to read:

1597.54. (a) All family daycare homes for children, shall apply for a license under this chapter, except that any home that, on June 28, 1981, had a valid and unexpired license to operate as a family daycare home for children under other provisions of law shall be deemed to have a license under this chapter for the unexpired term of the license, at which time a new license may be issued upon fulfilling the requirements of this chapter.

(b) An applicant for licensure as a family daycare home for children shall file with the department, pursuant to its regulations, an application on forms furnished by the department, which shall include, but not be limited to, all of the following:

(1) A brief statement confirming that the applicant is financially secure to operate a family daycare home for children. The department shall not require any other specific or detailed financial disclosure.

(2) (A) Evidence that the small family daycare home contains a fire extinguisher or smoke detector device, or both, that meets standards established by the State Fire Marshal under Section 1597.455, or evidence

that the large family daycare home meets the standards established by the State Fire Marshal under subdivision (a) of Section 1597.46.

(B) Evidence satisfactory to the department that there is a fire escape and disaster plan for the facility and that fire drills and disaster drills will be conducted at least once every six months. The documentation of these drills shall be maintained at the facility on a form prepared by the department and shall include the date and time of the drills.

(3) The fingerprints of any applicant of a family daycare home license, and any other adult, as required under subdivision (b) of Section 1596.871.

(4) Evidence of a current tuberculosis clearance, as defined in regulations that the department shall adopt, for any adult in the home during the time that children are under care. This requirement may be satisfied by a current certificate, as defined in subdivision (f) of Section 121525, that indicates freedom from infectious tuberculosis as set forth in Section 121525.

(5) Commencing September 1, 2016, evidence of current immunity or exemption from immunity, as described in Section 1597.622, for the applicant and any other person who provides care and supervision to the children.

(6) Evidence satisfactory to the department of the ability of the applicant to comply with this chapter and Chapter 3.4 (commencing with Section 1596.70) and the regulations adopted pursuant to those chapters.

(7) Evidence satisfactory to the department that the applicant and all other persons residing in the home are of reputable and responsible character. The evidence shall include, but not be limited to, a criminal record clearance pursuant to Section 1596.871, employment history, and character references.

(8) Other information as required by the department for the proper administration and enforcement of the act.

(c) Failure of the applicant to cooperate with the licensing agency in the completion of the application shall result in the denial of the application. Failure to cooperate means that the information described in this section and in regulations of the department has not been provided, or not provided in the form requested by the licensing agency, or both.

SEC. 15. Section 1597.543 of the Health and Safety Code is repealed.

SEC. 16. Section 1597.543 is added to the Health and Safety Code, to read:

1597.543. (a) The State Fire Marshal shall update the building and fire standards necessary to implement the sections of this chapter relating to life and fire safety, including, but not limited to, Sections 1597.455 and 1597.46, and shall publish the updates in the California Code of Regulations (CCR) in the next Title 19 and Title 24 CCR adoption cycle.

(b) Prior to the publication of the updates required by subdivision (a), but not later than January 1, 2021, the State Fire Marshal shall issue guidance on implementing the sections listed in subdivision (a).

(c) The State Fire Marshal shall update the regulations at least every three years to conform to changes in this chapter. The State Fire Marshal

may issue guidance on implementing this chapter annually in the years in which the regulations are not updated in Title 19 and Title 24 of the CCR.

O

94



**Item Attachment Documents:****5. Council Direction to Prepare a Report Pursuant to California Health and Safety Code Sections 13145 and 13146 to be Accepted by the Council**

## Recommended Action:

Direct staff to prepare the report for acceptance by the City Council at its January 21, 2020, regular meeting.



## Staff Report

**TO:** Mayor, and City Council Members  
**FROM:** Sean Thuilliez, Chief of Police  
**DATE:** January 7, 2020  
**SUBJECT:** Council Direction to Prepare a Report Pursuant to California Health and Safety Code Sections 13145 and 13146 to be Accepted by the Council

---

### Background and Analysis:

California Health and Safety Code Sections 13145 and 13146 require every city or county fire department or district providing fire protection services to enforce the fire code as adopted. Additionally, section 13146.2 requires the fire department to annually inspect every building used as a public or private school as well as all apartment houses, hotels, motels, and lodging houses for compliance. On September 27, 2018, Governor Brown approved Senate Bill 1205, which requires the fire department's compliance with the above-described inspection mandates..

Code Section 13146.4(b) requires that the report made pursuant to the statute shall occur when the administering authority discusses its annual budget, or at another time determined by the administering authority. Council direction is needed to establish a date in which the report will be accepted.

### Fiscal Impact:

No fiscal impact.

### Recommended Action:

Direct staff to prepare the report for acceptance by the City Council at its January 21, 2020, regular meeting.

**Item Attachment Documents:****6. Request for Destruction of Retention Met Records**

## Recommended Action:

Waive the full reading and adopt by title only, "A Resolution of the City of Beaumont Authorizing Destruction of Certain Records in Accordance with the Records Retention Schedule Adopted by City Council."



## Staff Report

**TO:** Mayor, and City Council Members  
**FROM:** Nicole Wheelwright, Deputy City Clerk  
**DATE:** January 7, 2020  
**SUBJECT:** Request for Destruction of Retention Met Records

---

### Background and Analysis:

As set forth in the Records Retention Schedule, adopted by City Council on October 2, 2018, certain records have met their retention and are no longer required to be kept on file. An on-going audit of records is being conducted, in which each file of records is being evaluated for retention status based on the contents. Records retention of each file is based on the document with the longest retention. Once a file has met its retention requirement it can be submitted for request of destruction and must be approved by the City Attorney, City Manager, City Clerk and brought to Council for final approval by way of resolution.

The attached request of destruction of certain records has met all approval requirements and is being presented for final approval by Council.

### Fiscal Impact:

No fiscal impact.

### Recommended Action:

Waive the full reading and adopt by title only, "A Resolution of the City of Beaumont Authorizing Destruction of Certain Records in Accordance with the Records Retention Schedule Adopted by City Council"

### Attachments:

- A. Resolution
- B. Request for Destruction of Retention Met Records

**RESOLUTION NO. 2020-**

**A RESOLUTION OF THE CITY OF BEAUMONT AUTHORIZING  
DESTRUCTION OF CERTAIN RECORDS IN ACCORDANCE  
WITH THE RECORDS RETENTION SCHEDULE ADOPTED BY  
CITY COUNCIL**

**WHEREAS**, on October 2, 2018 the City Council of the City of Beaumont (“City”) adopted Resolution No. 2018-51 entitled A Resolution of the City Council of the City of Beaumont, California, adopting a Records Retention Schedule, Authorizing Destruction of Certain City Records and Rescinding Resolutions 2012-01 and 1997-24; and

**WHEREAS**, the City’s Records Retention Schedule (“Schedule”) establishes a records management system which is a systematic control over the creation, acquisition, processing, use, protection, storage, and final disposition of all recorded information required by a municipal government to effectively conduct its business; and

**WHEREAS**, as set forth in the Schedule, City staff recommends that the documents described in Exhibit “A” attached hereto be authorized for destruction.

**NOW, THEREFORE, BE IT RESOLVED**, that the City of Beaumont authorizes that staff dispose of the documents described in Exhibit “A” attached hereto as authorized in the City of Beaumont’s Records Retention Schedule.

**MOVED, PASSED AND ADOPTED** this 7th day of January 2020.

AYES:

NOES:

ABSTAIN:

ABSENT:

**APPROVED:**

\_\_\_\_\_  
Rey Santos, Mayor

**ATTEST:**

\_\_\_\_\_  
Steven Mehlman, City Clerk

**APPROVED AS TO FORM:**

---

John O. Pinkney, City Attorney

**Exhibit A**  
**Request for Destruction of Records**



**CITY OF BEAUMONT**

To: City Attorney  
 From: Nicole Wheelwright, Deputy City Clerk  
 Subject: Request for Destruction of Records

I am requesting approval to destroy the records listed below because they have met the retention as specified in the City of Beaumont Retention Schedule. The records are not the subject of any claim, litigation, investigation, or audit.

\_\_\_\_\_  
 Department Head

\_\_\_\_\_  
 Date

DATE OF LAST DOCUMENT COMPLETED IN FOLDER	DESCRIPTION OF RECORD(S)	TOTAL RETENTION	RETENTION CODE NO.
09/06/2005	Project Progress Report – Noble Creek Park Improvements 702-04-01	Minimum of 2 years/no longer required	CC-011
06/25/2002	Certificate of Fee Exemption – Stewart park Playground Equipment 702-03-03	Minimum of 2 years/no longer required	CC-011
07/24/2009	Semi-Annual Report for Federal Grant – Sports Park 702-03-04	Minimum of 2 years/no longer required	CC-011
02/21/2006	Staff Report – Master Agricultural Reserve Plan 702-05-01	Minimum of 2 years/no longer required	CC-011
04/23/1998	Staff Report – World Changers Site Selection Committee 703-03-02	Minimum of 2 years/no longer required	CC-011
08/23/1994	Staff Report – Payment to School District for Block Grant Funds 704-01-04	Minimum of 2 years/no longer required	CC-011
03/06/1996	Correspondence from BUSD regarding Truancy Program 704-01-05	Minimum of 2 years/no longer required	CC-011
11/07/2000	Correspondence to BUSD regarding Safe Routes to Schools Program 704-01-07	Minimum of 2 years/no longer required	CC-011



06/06/2002	Correspondence to BUSD regarding Three Rings Elementary and Mountain View Middle Schools Will Service Sewer Letter 704-01-11	Minimum of 2 years/no longer required	CC-011	6.
06/14/2005	Correspondence from BUSD regarding proposal to close 5 <sup>th</sup> street 704-03-01	Minimum of 2 years/no longer required	CC-011	
06/17/2005	Correspondence from BUSD requesting fees to design an Aquatic Center 704-04-01	Minimum of 2 years/no longer required	CC-011	
12/05/1994	Correspondence regarding room rental 705-01-01	Minimum of 2 years/no longer required	CC-011	
02/03/2004	Staff Report – Authorizing submittal of application to Edison 800-01-01	Minimum of 2 years/no longer required	CC-011	
06/12/1995	Correspondence regarding a broken sewer line 801-02-01	Minimum of 2 years/no longer required	CC-011	
05/22/1995	Staff Report – Single Family Dwelling Sewer Connection 801-03-02	Minimum of 2 years/no longer required	CC-011	
05/06/1996	Staff Report – Placing Delinquent Sewer and Refuse Billing on County Tax Roll 801-03-03	Minimum of 2 years/no longer required	CC-011	
07/28/1994	Correspondence regarding costs of registering bonds and annual administration 1983-1 801-04-01	Minimum of 2 years/no longer required	CC-011	
04/28/1998	Staff Report – Authorizing submittal of application for construction loan for wastewater reclamation project 801-04-03	Minimum of 2 years/no longer required	CC-011	
05/12/1998	Staff Report – Sludge management 801-04-04	Minimum of 2 years/no longer required	CC-011	
01/04/1994	Correspondence regarding an alley sinkhole 807-01-01	Minimum of 2 years/no longer required	CC-011	
09/17/2001	Environmental Exemption – 6 <sup>th</sup> Street Widening Ph II 807-01-02	Minimum of 2 years/no longer required	CC-011	
09/25/1995	Staff Report – Approval of plans for Cherry Lane Alley Renovation 807-01-03	Minimum of 2 years/no longer required	CC-011	
06/30/1996	Correspondence regarding water supply irrigating Highland Springs slope 807-01-07	Minimum of 2 years/no longer required	CC-011	
09/23/1996	Staff Report – RDA concept plan review for 6 <sup>th</sup> Street Striping Project 807-01-08	Minimum of 2 years/no longer required	CC-011	

02/22/2000	Staff Report – Street Improvement Update 807-01-12	Minimum of 2 years/no longer required	CC-011	6.
01/07/1999	Staff Report – Request of Matching Funds for Highland Springs Road Improvements 807-01-13	Minimum of 2 years/no longer required	CC-011	
03/16/2000	Correspondence regarding a request to close Cherry Ave dirt extension N. of 11 <sup>th</sup>	Minimum of 2 years/no longer required	CC-011	
02/28/2001	Bid Documents for Oak View Street Improvements 807-01-16	2 years	AD-003	
03/19/2001	Correspondence regarding name change of 14 <sup>th</sup> Street 807-01-19	Minimum of 2 years/no longer required	CC-011	
07/17/2001	Staff Report - Approved plans and specs for Oak View Landscape improvements 807-01-21	Minimum of 2 years/no longer required	CC-011	
08/21/2001	Staff Report and Traffic Count for Sixth Street Rehabilitation 807-01-20	Minimum of 2 years/no longer required	CC-011	
02/04/2003	Road and Bridge Benefit Mitigation Fee Facility Fee Study 1001-08-01	Minimum of 2 years/no longer required	CC-011	
08/17/2010	Staff Report and Correspondence regarding the withdrawal from WRCOG 1001-06-01	Minimum of 2 years/no longer required	CC-011	
09/30/1996	Correspondence with the County of Riverside and Invoices regarding Beaumont Ave chip seal 807-01-51	Minimum of 2 years/no longer required	CC-011	
02/25/2002	Traffic Study of Orange Ave at 6 <sup>th</sup> Street 807-01-23	Minimum of 2 years/no longer required	CC-011	
Feb 1996	Unsigned Street Improvement Plans for Mountain View Middle School 807-02-01	Minimum of 2 years/no longer required	CC-011	
01/20/2004	Staff Report – Viele Avenue Street Closure for Railroad Crossing Improvements 807-04-01	Minimum of 2 years/no longer required	CC-011	
04/01/2004	Correspondence regarding four-way stop intersection at Viele and 6 <sup>th</sup> Street 807-05-01	Minimum of 2 years/no longer required	CC-011	
05/29/2002	Correspondence regarding a request for speed bumps in an alley 808-02-02	Minimum of 2 years/no longer required	CC-011	

APPROVALS:

\_\_\_\_\_  
City Attorney

\_\_\_\_\_  
Date

\_\_\_\_\_  
City Manager

\_\_\_\_\_  
Date

I certify that such destruction meets the requirements of the City's Records Retention Schedule and all applicable requirements of State and Federal law and have been approved by City Council by Resolution No. \_\_\_\_\_

\_\_\_\_\_  
City Clerk

\_\_\_\_\_  
Date of Records Destruction

**Item Attachment Documents:**

**7. Declaration of Surplus Property and Request for Disposal**

Recommended Action:

Approve disposal of identified City surplus property.



## Staff Report

**TO:** Mayor, and City Council Members  
**FROM:** Elizabeth Gibbs, Community Services Director  
**DATE:** January 7, 2020  
**SUBJECT:** Declaration of Surplus Property and Request for Disposal

---

### **Background and Analysis:**

Municipal Code Chapter 3.03, Section 010 specifically states that “a formal declaration that the property is surplus shall not be required.” With an asset inventory being maintained, surplus City property has been identified and a formal notification to City Council is reasonable.

All surplus property has been reviewed for possible reuse prior to requesting disposal. Disposal of surplus property will be made in the most economical and practical manner available.

### **Fiscal Impact:**

No significant impact.

### **Recommended Action:**

Approve disposal of identified City surplus property.

### **Attachments:**

A. Surplus Report

Assigned Asset Tag		Unit	VIN #	Serial No.	Make	Model	Description	Year	Engine	Fuel Type	Engine Size	License Plate	Mileage	Location
Dept	NO.													
PD	1026984		1FTYR44U92PA78171		FORD	RANGER 544423-8710	PICKUP TRUCK	2002		GAS		1026984		PD
CS	100372			102000036		4101	DISC CUTTER/OMC LINCOLN 30 GAL SPRAY TANK							CS
CS	N/A			250000253	TORO	74411	LAWN MOWER							CS
CS	100525			230007152	TORO	74176	LAWN MOWER							CS
CS	100523			250000318	TORO	30410	SMALL BATWING	2005						CS
CS	100557			210000473	TORO	30581	LAWN MOWER	2001						CS
CS						322W	ALL PRO							CS
CS				1285532		N/A	FMC PUMP							CS
CS	103082			250000318	TORO	30410	SMALL BATWING							CS
CS							RC-15AA RIM CLAMP							CS

**Item Attachment Documents:**

**8. Quarterly Status of City Council Travel and Training Reimbursements**

Recommended Action:

Receive and file.



## Staff Report

**TO:** Mayor, and City Council Members  
**FROM:** Nicole Wheelwright, Deputy City Clerk  
**DATE:** January 7, 2020  
**SUBJECT:** Quarterly Status of City Council Travel and Training Reimbursements

---

### **Background and Analysis:**

On August 20, 2019, City Council approved the allowance of a pre-approval travel expense reimbursement to each Council member in an amount not to exceed \$3,860 for Fiscal year 2019-2020. City Council also directed staff to report any such reimbursements on a quarterly basis. Attachment A reflects the reimbursements processed during October through December 2019. TEST OF CHANGES MADE TO REPORT

### **Fiscal Impact:**

The reimbursements are currently within the budgeted allotment.

### **Recommended Action:**

Receive and file.

### **Attachments:**

A. Travel Training and Meeting Reimb Quarterly Report



# Council Travel and Training Reimbursements Oct 1 - Dec 31 2019

## Council Travel Training and Local Meeting Budget

<i>FY 2019-2020 Budget</i>	
<i>Travel and Training and Local Meetings</i>	\$19,300.00
<b>Balance</b>	\$17,869.05

Date	Elected	Travel/Training/ Meeting	Reimbursed Amount	Notes
10/18/2019	Rey Santos	League of Ca Cities Conference	\$176.74	Mileage and Per Diem
10/23/2019	Julio Martinez	League of Ca Cities Conference	\$176.74	Mileage and Per Diem
10/23/2019	Michael Lara	League of Ca Cities Conference	\$657.50	Hotel and Mileage
10/30/2019	Lloyd White	League of Ca Cities Conference	\$230.48	Mileage and Parking
11/7/2019	Nancy Carroll	League of Ca Cities Conference	\$189.49	Mileage and Per Diem

**Item Attachment Documents:****9. Approve Implementation of National Community Survey Via Hard Copy Surveys with the Following Add-on Options: Larger Sample Size, Reminder Postcard, Spanish Translation, Custom Benchmark Comparisons, Open-Ended Question, and an In-Person Presentation****Recommended Action:**

Approve implementation of National Community Survey via hard copy surveys with the following add-on options: larger sample size, reminder postcard, Spanish translation, custom benchmark comparisons, open-ended question, and an in-person presentation with a budget not to exceed \$30,000.



## Staff Report

**TO:** Mayor, and City Council Members

**FROM:** Ashley Starr, Public Information Officer

**DATE:** Ashley 7, 2020

**SUBJECT:** Approve Implementation of National Community Survey Via Hard Copy Surveys with the Following Add-on Options: Larger Sample Size, Reminder Postcard, Spanish Translation, Custom Benchmark Comparisons, Open-Ended Question, and an In-Person Presentation

### Background and Analysis:

The National Community Survey (NCS) provides a comprehensive and accurate picture of livability and resident perspectives within the three pillars of a community: community characteristics, governance and participation. It also provides information across eight central facets of community: safety, mobility, natural environment, built environment, economy, recreation and wellness, education, enrichment and community engagement.

The NCS is an enterprise of National Research Center, Inc., and the International City/County Management Association (ICMA), and was developed to produce clear, unbiased, actionable results that local government leaders can rely on.

NCS uses scientific survey methods to guarantee valid findings and puts results into meaningful context. Drawing from a resident opinion database of over 30 million Americans, the NCS compares local results with benchmarks compiled from surveys conducted across the United States. The results of the survey can be used to improve service delivery, strengthen communications with community stakeholders, and identify clear priorities for use in strategic planning and budget setting.

City staff proposes to conduct ongoing surveys every three to five years in order to track trends, gauge citizen perceptions, and solicit feedback.

### Fiscal Impact:

#### NCS Timeline:

- Month 1 - Complete worksheet and generate sample questionnaire.
- Month 2 - Postcard notifications and surveys mailed to residents.
- Month 3 - Data collection and processing.
- Month 4 - Draft and final reports delivered.

The National Community Survey has three (3) survey options:

**Web Data Collection**

- 1,800 households; and
- Households contacts via mailed invitations using a random sample from a USPS address list.

**Hard Copy Surveys Sent by Mail**

- 1,700 households; and
- Mailed survey also available at no added cost.

**Open Participation Web Data Collection**

- All residents eligible,
- No random sampling and no mailings, and
- City sponsored advertising.

All options come standard with the following:

- Full report of results,
- Responses weighted to reflect characteristics of your entire community,
- Benchmarking against more than 500 citizen survey results,
- Tracking of results and response rates by geographic area,
- Opt-in web survey, and
- Custom questions specific to jurisdiction.

A variety of add-on options are available for each method. A 10% discount is given to International City/County Management Association (ICMA) member agencies of which Beaumont is a member. See attachment A for pricing.

**Recommended Action:**

Approve implementation of National Community Survey via hard copy surveys with the following add-on options: larger sample size, reminder postcard, Spanish translation, custom benchmark comparisons, open-ended question, and an in-person presentation with a budget not to exceed \$30,000.

**Attachments:**

- A. Survey and Add-on Option Pricing



### 2019 Pricing for The National Community Survey

Join hundreds of other local governments and get a representative picture of residents' needs and perspectives with The National Community Survey™ (The NCS™).

The NCS Basic Service Includes:

- [License to use the survey template.](#)
- Full report of results, plus multiple layers of reporting to meet the needs of different stakeholders
- Responses weighted to reflect characteristics of your entire community
- Benchmarking against more than 500 other community survey results
- Tracking of results and response rates by geographic area
- Opt-in web survey included in addition to the scientific, random-sampled survey
- Space reserved for custom questions specific to your jurisdiction, crafted with guidance from your NRC project manager
- \*Exclusive access to the [NRC Playbook of Strategies](#)
- \*Exclusive access to the [NRC Resource Group](#)

*\*Contact your Project Manager for access to the NRC Playbook of Strategies and NRC Resource Group.*

Web Data Collection	<b>HARD COPY SURVEYS SENT BY MAIL</b> most common choice	OPEN PARTICIPATION WEB DATA COLLECTION all residents are eligible
<b>\$14,120</b> \$12,705 DISCOUNTED PRICE*	<b>\$17,435</b> \$15,690 DISCOUNTED PRICE*	<b>\$10,190</b> \$9,170 DISCOUNTED PRICE*
Sample size of 1,800 households included	Sample size of 1,700 households included	You promote participation
Households contacted via mailed invitations using a random sample from a USPS address list	Mailed survey also available online at no added cost	No random sampling
		No mailings



## Add-On Options

	Full Price	Discounted Price*	Notes
<b>Larger Sample Size</b>	Varies	Varies	See below for example sample sizes
<b>Reminder Postcard (4th Mailing)</b>	Varies	Varies	See below for example sample sizes
<b>Demographic Subgroup Comparison Report</b>	\$1,015	\$910	Compare results by population demographics (age, sex, race/ethnicity, housing tenure and housing unit type)
<b>Geographic Subgroup Comparison Report</b>	\$1,015	\$910	Compare results by geographic area
<b>Spanish</b>	\$1015	\$910	Respondents can complete the survey online in Spanish
<b>Custom Benchmark Comparisons</b>	\$1,210	\$1,085	Benchmark results against communities meeting specific criteria
<b>One Open-ended Question</b>	\$2,375	\$2,135	Includes one open-ended question added to survey. Responses will be categorized and reported in a table under separate cover, accompanied by a complete list of verbatim responses.
<b>In-person Presentation</b>	\$3,890	\$3,500	Assumes location within 50 miles of int'l airport
<b>Next Steps Workshop</b>	\$6,070	\$5,460	Assumes location within 50 miles of int'l airport
<b>Compare Prior Results</b>	\$2,260	\$2,030	Compare current results to those of a previous survey (not The NCS)

## Example Sample Sizes

	Regular mailing (3 contacts)		Reminder postcard (4th contact)	
	Full Price	Discounted Price	Full Price	Discounted Price
<b>+0 (1,700 total)</b>	–	–	<b>\$1,075</b>	<b>\$965</b>
<b>+400 (2,100 total)</b>	<b>\$1,880</b>	<b>\$1,690</b>	<b>\$1,275</b>	<b>\$1,145</b>
<b>+800 (2,500 total)</b>	<b>\$3,310</b>	<b>\$2,975</b>	<b>\$1,470</b>	<b>\$1,320</b>
<b>+1,200 (2,900 total)</b>	<b>\$4,735</b>	<b>\$4,260</b>	<b>\$1,670</b>	<b>\$1,500</b>
<b>+1,600 (3,300 total)</b>	<b>\$6,165</b>	<b>\$5,545</b>	<b>\$1,865</b>	<b>\$1,675</b>

\*Please note all prices are subject to change. Pricing assumes up to four geographic subareas; let us know if you need a custom quote for more subareas.

### \*Discount Eligibility\*

You are eligible for a 10% discount on The NCS, The NES, The NBS or CASOA if you:

- ✓ Have conducted any of these surveys in the past
- ✓ Are an ICMA member
- ✓ Are an NLC member
- ✓ Are an Association of Government Accountants member

Not sure if you're eligible?

[Contact Us](#)

### Why Local Governments Should Survey Residents



LEARN MORE ABOUT THE NCS

National Research Center, Inc. (NRC) is a leading full-service survey research and evaluation firm focusing on the information requirements of the public sector, including local governments, health care providers, foundations and non-profit organizations. Visit our home on the web at [www.n-r-c.com](http://www.n-r-c.com). Check out our [News and Knowledge](#) page for more updates, tips and stories from NRC.

Like our content? Subscribe to The Civil Review:

SIGN UP



ADD COMMENT

You must be [logged in](#) to post a comment.

< PREV

NEXT >



- NATIONAL RESEARCH CENTER
- > THE NATIONAL COMMUNITY SURVEY
- > COMMUNITY ASSESSMENT SURVEY FOR OLDER ADULTS
- > THE NATIONAL BUSINESS SURVEY
- > THE NATIONAL EMPLOYEE SURVEY
- > NATIONAL POLICE SERVICES SURVEY
- > NRC EMPLOYMENT

- RESOURCES
- > GET STARTED
- > THE CIVIL REVIEW
- > NRC RESOURCE GROUP
- > NCS FAQ
- > COPYRIGHT INFORMATION
- > TERMS OF USE

GET IN TOUCH

2955 Valmont Road, Suite 300  
 Boulder, Colorado 80301  
 phone: 303.444.7863 | toll free: 877.467.2462  
 fax: 303.444.1145  
[nrc@n-r-c.com](mailto:nrc@n-r-c.com)



**Item Attachment Documents:****10. Updates of the Annual Slurry Seal Project (CIP2019-001), Alleyway Rehabilitation Project (CIP2018-003), Beaumont Avenue Rehabilitation Project (CIP2018-004 & CIP2019-002), Beaumont Avenue Signalization Study (CIP2019-017), and the City Crack Sealing Operation****Recommended Action:**

Receive and file updates for the Annual Slurry Seal Project (CIP2019-001), Alleyway Rehabilitation Project (CIP2018-003), Beaumont Avenue Rehabilitation Project (CIP2018-004 & CIP2019-002), Beaumont Avenue Signalization Study (CIP2019-017), and the City Crack Sealing Operation.





## Staff Report

**TO:** Mayor, and City Council Members  
**FROM:** Jeff Hart, Public Works Director  
**DATE:** January 07, 2020  
**SUBJECT:** Updates of the Annual Slurry Seal Project (CIP2019-001), Alleyway Rehabilitation Project (CIP2018-003), Beaumont Avenue Rehabilitation Project (CIP2018-004 & CIP2019-002), Beaumont Avenue Signalization Study (CIP2019-017), and the City Crack Sealing Operation

### **Background and Analysis:**

#### Annual Slurry Seal Project (CIP2019-001) Update:

The City's annual slurry seal project will apply slurry seal to approximately 213,800 square yards (7.1 centerline miles) of existing street surfaces throughout the City (refer to Attachment A for location and limits of the project). The slurry seal project funding is provided by a combination of Measure 'A' and road maintenance and rehabilitation account (RMRA) funds in accordance with the Road Repair and Accountability Act of 2017 (SB-1). The project has a budget of \$1,000,000.

On December 10, 2019, the Public Works department received the final plans and specifications for review. It is anticipated the project will be advertised for bidding in January and presented to City Council for award in February 2020. The project has a 60 calendar-day construction duration.

#### Alleyway Rehabilitation Project (CIP2018-003) Update:

The Alleyway Rehabilitation Project will remove and replace approximately 9,000 square feet of asphalt concrete (AC) along the alley, east of Beaumont Avenue, between 9th Street and 10th Street (refer to Attachment A for location and limits of the project). The Alleyway Rehabilitation Project funding is provided by alley in-lieu DIF funds, which has a budget allocation of \$34,000.

Michael Baker International (MBI), the design consultant, provided completed project and specifications plans at the end of December. It is anticipated that the project will be advertised for bidding in January and presented to City Council for award in February 2020. The project has a 60 calendar-day construction duration.

#### Beaumont Avenue Rehabilitation Project (CIP2018-004 & CIP2019-002) Update:

The Beaumont Avenue Rehabilitation Project will remove and replace approximately 40,000 square feet of AC, and grind and overlay approximately 525,000 square feet of existing AC with 3 inches of new AC paving. The combined efforts will place approximately 5,700 tons of new AC paving along 2.3 centerline miles of Beaumont Avenue. This project occurs along Beaumont Avenue, from 5th Street to Brookside Avenue (refer to Attachment A for location and limits of the project). Beaumont Avenue Rehabilitation Project funding is provided by a combination of Measure 'A' and SB-1 funds. This project has a budget of \$2,234,000, however, based on current funding levels and bid results, the project will be phased over the next few years.

Michael Baker International (MBI), the design consultant, provided completed project and specifications plans at the end of December. It is anticipated that the project will be advertised for bidding in January and presented to City Council for award in February 2020. The project has a 60 calendar-day construction duration.

#### Beaumont Avenue Signalization Study (CIP2019-017) Update:

On April 16, 2019, City Council awarded MBI the contract to perform a traffic study analyzing the intersection along Beaumont Avenue, from 6th Street to Oak Valley Parkway. The focus of the study was to determine which intersections, if any, can be signalized. The study was funded with Traffic Signal DIF funds with a budget of \$14,470.

MBI provided a 95% study on July 30, 2019, in which staff reviewed and identified several areas where additional analysis was required. MBI submitted a final study on December 6, 2019, in which staff reviewed and accepted. The total cost of the study, including the final invoice, is anticipated to not exceed \$14,470.

The results of the Beaumont Avenue Signalization Study show that traffic signal warrants are not currently met based on the Existing Year 2019 traffic volumes. The operations analysis results show that all locations currently operate at acceptable levels (LOS D or better overall, or on all individual movements). While signal warrants are not currently met, if growth occurs in the area, it is most likely that the intersections of Beaumont Avenue and E. 12th Street, and Beaumont Avenue and E. 8th Street will require signalization in the future.

An assessment of the left turn movements at the intersection of Beaumont Avenue and E. 6th Street showed that the eastbound and westbound left turn movements are below the volume thresholds which would require protected movements.

An evaluation of conversion from four-way stop conditions to two-way stop conditions shows that two (2) of the four (4) intersections analyzed are potential candidates for conversion based upon the level of service operations analysis. The potential candidates for a four-way to two-way stop conversion are Beaumont Avenue at 9th Street, and Beaumont Avenue at 10th Street. MBI is concluding the analysis on whether

these two potential intersections should be converted. It is anticipated that MBI will conclude the analysis in January.

City Crack Sealing Operation Update:

On May 21, 2019, City Council approved the purchase of a crack seal machine. Since then, City staff has performed crack sealing on approximately 16,100 linear feet (3.0 centerline miles) of existing AC paving. Furthermore, as part of the Fiscal Year 19/20, staff is projecting an additional 63,800 linear feet (12.1 centerline miles) of crack sealing (refer to Attachment A for location and limits of the Fiscal Year 19/20, City Crack Seal Operation). The City crack seal operation is funded by Measure 'A' and local funds.

**Fiscal Impact:**

The cost to prepare the staff report is approximately \$350.

**Recommended Action:**

Receive and file updates for the Annual Slurry Seal Project (CIP2019-001), Alleyway Rehabilitation Project (CIP2018-003), Beaumont Avenue Rehabilitation Project (CIP2018-004 & CIP2019-002), Beaumont Avenue Signalization Study (CIP2019-017), and the City Crack Sealing Operation.

**Attachments:**

- A. 19\_20 FY Street Capital Improvement Projects



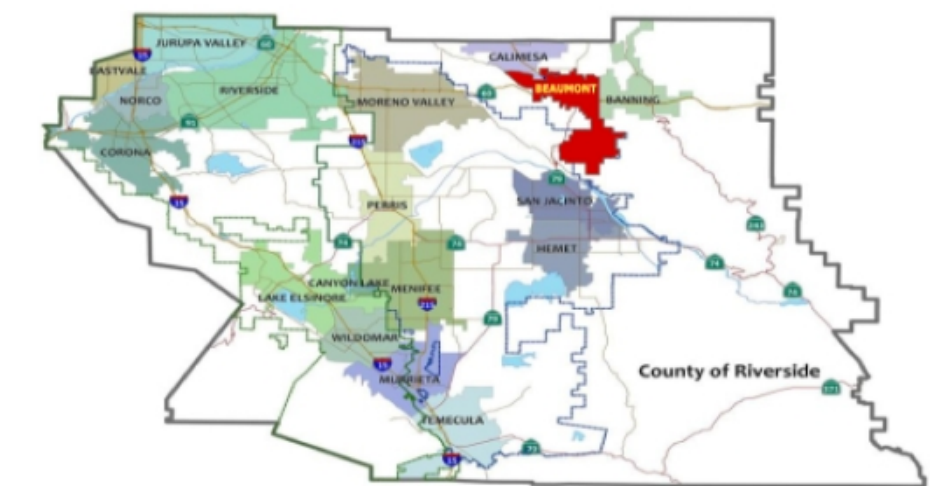

- LEGEND**
- Annual Slurry Seal Project (CIP2019-001)
  - Alleyway Rehabilitation Project (CIP2018-003)
  - Beaumont Avenue Rehabilitation Project (CIP2018-004 & 2019-002)
- 19/20 City Crack Sealing Operation**
- Completed
  - Anticipated
  - City Limits

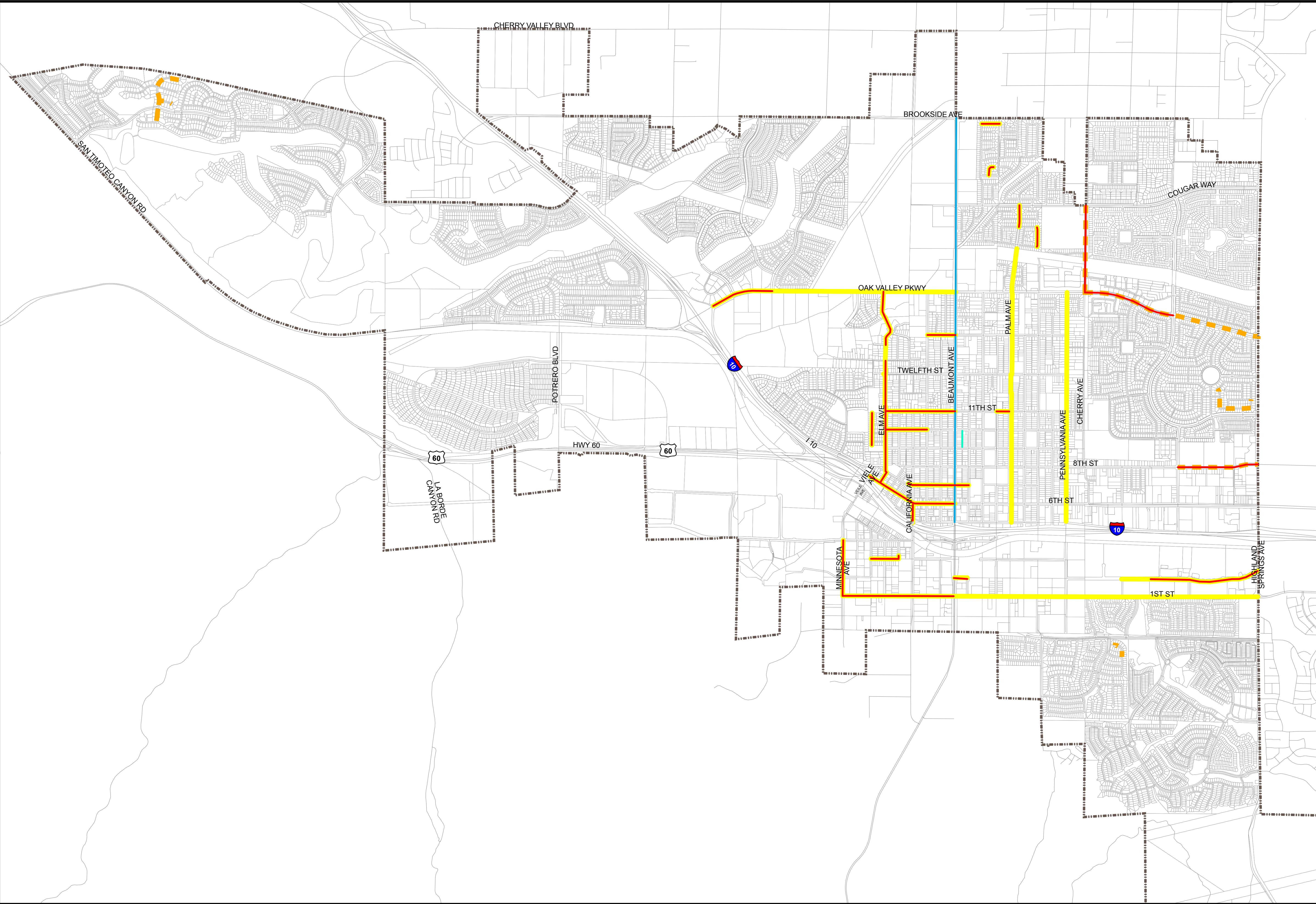

NOTE TO SCALE

Date Created: 12/13/19

**CITY OF BEAUMONT**  
**19/20 FY STREET CAPITAL IMPROVEMENT PROJECTS**  
**PUBLIC WORKS DEPARTMENT**

**CITY OF BEAUMONT**  
 Public Works Department  
 550 E. 6th Street  
 Beaumont, CA 92223  
 (951) 769-8522  
 BeaumontCa.gov



**Item Attachment Documents:****11. Approve the Purchase of One (1) F150 Super Crew Work Truck and One (1) F350 Super Crew Utility Truck in the Amount of \$74,760.75 from Fritts Ford**

## Recommended Action:

Approve staff to purchase one F150 Super Crew work trucks and one F350 Super Crew utility Bed truck in the amount of \$74,760.75 from Fritts Ford.



## Staff Report

**TO:** Mayor, and City Council Members  
**FROM:** Thaxton Van Belle, Chief Plant Operator  
**DATE:** January 7, 2020  
**SUBJECT:** Approve the Purchase of One (1) F150 Super Crew Work Truck and One (1) F350 Super Crew Utility Truck in the Amount of \$74,760.75 from Fritts Ford

### Background and Analysis:

The Wastewater Department requests the purchase of two new work truck – a half ton work truck and a one tone utility bed work truck. The acquisition of these vehicles was approved by Council in the Fiscal Year 19/20 budget. The Wastewater Department requested quotes from three dealers who sell Ford fleet trucks (Fairview Ford, Fritts Ford, and Sunrise Ford) to purchase one F15 Super Crew and one F350 Super Crew with utility bed.

The City received quotes from three (30 bidders 9see attached) – Fairview Ford, Fritts Ford, and Sunrise Ford. The lowest bidder for each truck was Fritts Ford, summarized below:

Sunrise Ford:  
 2019 F150 Super Crew \$30,064.10  
 2019 F350 Utility Bed \$48,993.67  
**Total: \$79,057.77**

Fairview Ford:  
 2020 F150 Super Crew \$28,021.60  
 2020 F350 Utility Bed \$47,415.52  
**Total \$75,437.12**

Fritts Ford:  
 2020 F150 Super Crew \$27,530.50  
 2020 F350 utility Bed \$47,230.25  
**Total \$74,760.75**

**Fiscal Impact:**

The total cost for purchasing the two work trucks is \$74,760.75 and will be funded from account #710-0000-8060-0000 and are within the budgeted allotment.

**Recommended Action:**

Approve staff to purchase one F150 Super Crew work trucks and one F350 Super Crew utility Bed truck in the amount of \$74,760.75 from Fritts Ford.

**Attachments:**

- A. 2020 Work Truck Quotes



16005 VALLEY BLVD., FONTANA, CA 92335  
FLEET OFFICE (909) 350-3043 FLEET FAX (909) 822-4199

### FLEET VEHICLE PURCHASE INVOICE

SOLD TO City of Beaumont DATE 11/21/2019  
Kevin Lee  
550 E 6th St  
PHONE 909-725-5047  
P.O. # 494057

YEAR 2019 MAKE Ford MODEL F-150  
VIN 1FTEW1CP4KKF03539 STOCK NUMBER FK5021

**TERMS:**

NET 30 DAYS NET DUE \$ 30064.10

MUST BE RECEIVED NO LATER THAN 12/21/2019

DELIVERY RECEIPT:  
I ACKNOWLEDGE THE RECEIPT OF THE ABOVE VEHICLE:

MAKE CHECKS PAYABLE TO:  
**SUNRISE FORD**  
16005 VALLEY BLVD.  
FONTANA, CA 92335

SUNRISE  
\$ 30,064<sup>10</sup>  
\$ 48,993<sup>67</sup>  
-----  
\$ 79,057<sup>77</sup>  
  
NOTE: 2019 MODEL YR

DATE \_\_\_\_\_  
PRICE 27780.75  
TAX 2159.60  
LIC. FEE 30.00  
DOC. FEE \$85.00  
TOTAL 30064.10  
LESS TRADE \_\_\_\_\_  
LESS DOWN \_\_\_\_\_  
NET DUE 30064.10





#1 Ford Commercial Vehicle Center Dealer in California  
Sunrise Ford Fontana: [\(909\) 787-2728](tel:9097872728)  
16005 Valley Blvd., Fontana, CA 92335

[← Back To Search Results](#)



**Price: \$39,305**

**[View Price Details](#)**

**2019 F-150 SuperCrew Cab 4x2, Pickup (Stock #FK5021)**

[← Back To Search Results](#)



Photos may be library images.

## Pricing Details

<b>MSRP</b>	<b>\$39,305</b>
-------------	-----------------

**Contact Sunrise Ford Fontana for more  
info.**

**(909) 787-2728**

**Vehicle available NOW in Fontana, CA**





16005 VALLEY BLVD., FONTANA, CA 92335  
FLEET OFFICE (909) 350-3043 FLEET FAX (909) 822-4199

### FLEET VEHICLE PURCHASE INVOICE

SOLD TO City of Beaumont DATE 11/21/2019  
Kevin Lee  
550 E 6th St  
PHONE 909-725-5047  
P.O. # 494068

YEAR 2019 MAKE Ford MODEL F-350  
VIN 1FD8W3F67KEG13457 STOCK NUMBER FK4959

**TERMS:**  
NET 30 DAYS NET DUE \$ 48993.67  
MUST BE RECEIVED NO LATER THAN 12/21/2019

DELIVERY RECEIPT:  
I ACKNOWLEDGE THE RECEIPT OF THE ABOVE VEHICLE:  
  
SIGNATURE \_\_\_\_\_ DATE \_\_\_\_\_  
  
FORD FLEET # \_\_\_\_\_  
  
RESALE # \_\_\_\_\_  
  
R.S. # \_\_\_\_\_  
  
BID # \_\_\_\_\_  
  
FLEET MANAGER & NUMBER \_\_\_\_\_

**MAKE CHECKS PAYABLE TO:**  
**SUNRISE FORD**  
**16005 VALLEY BLVD.**  
**FONTANA, CA 92335**  
  
PRICE 45348.80  
TAX 3521.12  
LIC. FEE 30.00  
DOC. FEE \$85.00  
TOTAL 48993.67  
  
LESS TRADE \_\_\_\_\_  
LESS DOWN \_\_\_\_\_  
NET DUE 48993.67



COMMERCIAL  
VEHICLE CENTER



#1 Ford Commercial Vehicle Center Dealer in California  
Sunrise Ford Fontana: [\(909\) 787-2728](tel:9097872728)  
16005 Valley Blvd., Fontana, CA 92335

[← Back To Search Results](#)



**Price: \$49,988**

**[View Price Details](#)**

**2019 F-350 Crew Cab 4x4, Scelzi Signature Service Body (Stock #FK4959)**

[← Back To Search Results](#)



# SCELZI

## TRUCK BODIES

11.

### Pricing Details

<b>MSRP</b>	<b>\$57,490</b>
Retail Customer Cash	- \$1,250
Sale Discount	- \$3,752
Ford Credit Retail Bonus Customer Cash	- \$1,000
Upfit Bonus Customer Cash	- \$1,000
2019 Commercial Vehicle Season Bonus Cash	- \$500
<b>Price</b>	<b>\$49,988</b>
Total Savings	\$7,502

**Contact Sunrise Ford Fontana for more  
info.  
(909) 787-2728**

**Vehicle available NOW in Fontana, CA**

**Disclaimer:**

All advertised vehicles are subject to actual dealer availability. Certain vehicles listed may not be available, or may have different prices. Prices exclude state tax, license, document preparation fee, smog fee, and finance charges, if applicable. Vehicle option and pricing are subject to change. Prices include all dealer incentives. Pricing and availability varies by dealership. Please check with your dealer for more information. Prices do not include dealer charges, such as advertising, that can vary by manufacturer or region, or costs for selling, preparing, displaying or financing the vehicle. Images displayed may not be representative of the actual trim level of a vehicle. Colors shown are the most accurate representation available. However, due to the limitations of web and monitor color display, we cannot guarantee that the colors depicted **143** exactly match the color of the car. Information provided is



A

FAIRVIEW

\$28,021<sup>60</sup>  
\$47,415<sup>52</sup>  
\$75,437<sup>12</sup>



FAIRVIEW FORD SALES, INC  
MET AND TRUCK CENTER  
10 WEST 2<sup>ND</sup> STREET  
P O BOX 1390  
SAN BERNARDINO CA 92402  
(909) 386-0281 FAX #: (909) 386-0292

VEHICLE ORDER CONFIRMATION

12/02/19 16:15:46  
Dealer: F71156  
Page: 1 of 2  
Price Level: 020

2020 F-SERIES SD

Order No: 0000 Priority: A4 Ord FIN: Order Type:  
Ord PEP: 630A Cust/Flt Name: BEAUMONT PO Number:

	RETAIL		RETAIL
W3F F350 4X4CRWCCSR	\$41250	90L PWR EQUIP GROUP	\$1125
	.179" WHEELBASE		TELE TT MIR-PWR
Z1 OXFORD WHITE		17F XL DECOR PKG	NC
A VNYL 40/20/40		18B PLAT RUNNING BD	445
S MEDIUM EARTH GR			11400# GVWR PKG
630A PREF EQUIP PKG		425 50 STATE EMISS	NC
	.XL TRIM	43C 110V/400W OUTLT	175
572 .AIR CONDITIONER	NC		
	.AMFM/MP3/CLK		
996 6.2L EFI V8 ENG	NC	TOTAL BASE AND OPTIONS	46020
44G 10-SPD AUTOMATC	NC	TOTAL	46020
TCH .LT275/65BSWAS18	NC		
X37 3.73 REG AXLE	NC		
512 SPARE TIRE/WHL2	350		
61J JACK	NC		

\* INCLUDES PACIFIC SERVICE BODY  
PER SPEC. \*

VEHICLE ORDER CONFIRMATION

12/02/19 16:15:54  
Dealer: F71156  
Page: 2 of 2  
Price Level: 020

2020 F-SERIES SD

Order No: 0000 Priority: A4 Ord FIN: Order Type:  
Ord PEP: 630A Cust/Flt Name: BEAUMONT PO Number:

	RETAIL		RETAIL
JOB #1 BUILD			
52B BRAKE CONTROLLER	270		
67E 240 AMP ALTRNTR	85		
REMARKS TRAILER			
96V XL VALUE PKG	725		
	.CRUISE CONTROL		
	SP FLT ACCT CR		
	FUEL CHARGE		
	PRICED DORA		
	DEST AND DELIV	1595	

SALES PRICE A+B \$ 43997<sup>00</sup>  
7.75% SALES TAX \$ 3409<sup>77</sup>  
CAL. TIRE FEE \$ 875  
DMV \$ EXEMPT  
TOTAL \$ 47,415<sup>52</sup>  
EACH.



**FAIRVIEW FORD SALES, INC**  
**FLEET AND TRUCK CENTER**  
**740 WEST 2<sup>ND</sup> STREET**  
**P O BOX 1390**  
**SAN BERNARDINO CA 92402**  
 PHONE #:(909) 386-0281 FAX #:(909) 386-0292

VEHICLE ORDER CONFIRMATION

12/02/19 15:55:51

Dealer: F71156

Page: 1 of 2

Price Level: 020

2020 F-150

Order No: 0000 Priority: B3 Ord FIN: Order Type:  
 Ord PEP: 101A Cust/Flt Name: BEAUMONT PO Number:

	RETAIL			RETAIL	
W1C	F150 4X2 CREW	\$35035		CA BOARD FEES	NC
	145" WHEELBASE			FRT LICENSE BKT	NC
YZ	OXFORD WHITE		168	FLOOR CARPET	145
W	CLTH BUCKT SEAT	295	422	CALIF EMISSIONS	NC
G	MED EARTH GRAY			SYNC	
101A	EQUIP GRP	2480			
	.XL SERIES			TOTAL BASE AND OPTIONS	41470
	.POWER EQUIP GRP			XL MID DISCOUNT	(750)
	.FORDPASS CONNCT			XL MID DISCT CHROME AP	(500)
	.CRUISE CONTROL			TOTAL	40220
99P	2.7L V6 ECOBST	995			
44G	ELEC 10-SPDAUTO				
	.245/70R-17 A/S				
X19	3.55 REG AXLE	NC			
	6360# GVWR				

\* EST. 90 DAY DELIVERY A.R.O. \*

VEHICLE ORDER CONFIRMATION

12/02/19 15:55:59

Dealer: F71156

Page: 2 of 2

Price Level: 020

2020 F-150

Order No: 0000 Priority: B3 Ord FIN: v Order Type:  
 Ord PEP: 101A Cust/Flt Name: BEAUMONT PO Number:

	RETAIL			RETAIL	
53B	CLASS IV HITCH	\$150		TOTAL	\$40220
86A	REMARKS TRAILER				
	XL CHROME PKG	775			
	.CHROME BUMPERS				
	.FOG LAMPS				
	.17" SILVER ALUM				
	SP FLT ACCT CR				
	FUEL CHARGE				
	PRICED DORA	NC			
	DEST AND DELIV	1595			

SALES PRICE \$ 25998<sup>00</sup>

7.75% SALES TAX \$ 2014<sup>85</sup>

CAL. TIRE FEE \$ 8<sup>75</sup>

DMV \$ EXEMPT

TOTAL \$ 28,021<sup>60</sup>

EACH.

TOTAL BASE AND OPTIONS	41470
XL MID DISCOUNT	(750)
XL MID DISCT CHROME AP	(500)





Prepared by: Vikiy Garay  
11/27/2019

Fritts Ford | 8000 Auto Drive Riverside California | 925044193

2020 F-150 4x2 SuperCrew Cab Styleside 5.5' box 145" WB XL (W1C)

Price Level: 20

## As Configured Vehicle

Code	Description
<b>Base Vehicle</b>	
W1C	Base Vehicle Price (W1C)
<b>Packages</b>	
101A	<p>Equipment Group 101A Mid</p> <p><i>Includes:</i></p> <ul style="list-style-type: none"> <li>- 3.55 Axle Ratio</li> <li>- Tires: P245/70R17 BSW A/S</li> <li>- Cloth 40/20/40 Front Seat <i>Includes 2-way manual driver/passenger adjustment and armrest.</i></li> <li>- Radio: AM/FM Stereo w/6 Speakers <i>Includes auxiliary audio input jack (not available with SYNC).</i></li> <li>- XL Power Equipment Group</li> <li>- Power Glass Sideview Mirrors w/Black Skull Caps <i>Includes manual-folding.</i></li> <li>- Illuminated Entry</li> <li>- MyKey</li> <li>- Perimeter Alarm</li> <li>- Power Door Locks <i>Includes flip key and integrated key transmitter keyless-entry (includes Autolock).</i></li> <li>- Power Tailgate Lock</li> <li>- Power Front &amp; Rear Windows</li> <li>- 4.2" Productivity Screen in Instrument Cluster <i>Includes compass.</i></li> <li>- FordPass Connect 4G Wi-Fi Modem <i>Includes 4G LTE Wi-Fi hotspot connects up to 10 devices, remotely start, lock and unlock vehicle, schedule specific times to remotely start vehicle, locate parked vehicle and check vehicle status. Note: Ford Telematics and Data Services Prep included for Fleet Only. FordPass Connect 4G Wi-Fi Modem provides data to support telematics and data services including but not limited to vehicle location, speed, idle time, fuel, vehicle diagnostics and maintenance alerts. Device enables telematics services through Ford or authorized providers. Activate at <a href="http://www.fleet.ford.com">www.fleet.ford.com</a> or call 833-FCS-FORD or 833-327-3673. Includes a complimentary trial subscription of 3 months or 3 gigabytes whichever comes first, wireless service plan required after trial subscription ends. Visit <a href="http://att.com/ford">att.com/ford</a> to start complimentary trial and sign up for a wireless service plan.</i></li> <li>- SYNC <i>Includes enhanced voice recognition communications and entertainment system, 911 assist, 4.2" LCD display in center stack, Applink and 1 smart charging USB port.</i></li> <li>- Cruise Control</li> </ul>
<b>Powertrain</b>	
99P	<p>Engine: 2.7L V6 EcoBoost</p> <p><i>Includes auto start-stop technology.</i></p> <p><i>Includes:</i></p> <ul style="list-style-type: none"> <li>- GVWR: 6,360 lbs Payload Package</li> </ul>
44G	<p>Transmission: Electronic 10-Speed Automatic</p> <p><i>Includes selectable drive modes: normal/tow-haul/snow-wet/EcoSelect/sport.</i></p>
X19	3.55 Axle Ratio

FRITTS

\$27,530<sup>50</sup>

\$47,230<sup>25</sup>

---

\$74,760<sup>75</sup>

Prices and content availability as shown are subject to change and should be treated as estimates only. Actual base vehicle, package and option pricing may vary from this estimate because of special local pricing, availability of equipment and other adjustments not reflected in the dealer's computer system. See salesperson for the most current information.





Prepared by: Vikiy Garay  
11/27/2019

Fritts Ford | 8000 Auto Drive Riverside California | 925044193

2020 F-150 4x2 SuperCrew Cab Styleside 5.5' box 145" WB XL (W1C)

Price Level: 20

## As Configured Vehicle (cont'd)

Code	Description
NONGV1	GVWR: 6,360 lbs Payload Package
<b>Wheels &amp; Tires</b>	
STDTR	Tires: P245/70R17 BSW A/S
64F	Wheels: 17" Silver Painted Aluminum
<b>Seats &amp; Seat Trim</b>	
C	Cloth 40/20/40 Front Seat <i>Includes 2-way manual driver/passenger adjustment and armrest.</i>
<b>Other Options</b>	
145WB	145" Wheelbase
STDRD	Radio: AM/FM Stereo w/6 Speakers <i>Includes auxiliary audio input jack (not available with SYNC).</i>
86A_	XL Chrome Appearance Package <i>Includes:</i> - Wheels: 17" Silver Painted Aluminum - Front & Rear Chrome Bumpers <i>Includes body-color front fascia.</i> - Fog Lamps
PAINT	Monotone Paint Application
595_	Fog Lamps
153	Front License Plate Bracket <i>Standard in states requiring 2 license plates, optional to all others.</i>
<b>Fleet Options</b>	
85A	XL Power Equipment Group <i>Includes:</i> - Power Glass Sideview Mirrors w/Black Skull Caps <i>Includes manual-folding.</i> - Illuminated Entry - MyKey - Perimeter Alarm - Power Door Locks <i>Includes flip key and integrated key transmitter keyless-entry (includes Autolock).</i> - Power Tailgate Lock - Power Front & Rear Windows
60M	FordPass Connect 4G Wi-Fi Modem Requires valid VIN code.

Prices and content availability as shown are subject to change and should be treated as estimates only. Actual base vehicle, package and option pricing may vary from this estimate because of special local pricing, availability or price adjustments not reflected in the dealer's computer system. See salesperson for the most current information.



Prepared by: Vikiy Garay  
11/27/2019

Fritts Ford | 8000 Auto Drive Riverside California | 925044193

2020 F-150 4x2 SuperCrew Cab Styleside 5.5' box 145" WB XL (W1C)

Price Level: 20

As Configured Vehicle (cont'd)

Code	Description
52P	<p>Includes 4G LTE Wi-Fi hotspot connects up to 10 devices, remotely start, lock and unlock vehicle, schedule specific times to remotely start vehicle, locate parked vehicle and check vehicle status. Note: Ford Telematics and Data Services Prep included for Fleet Only; FordPass Connect 4G Wi-Fi Modem provides data to support telematics and data services including but not limited to vehicle location, speed, idle time, fuel, vehicle diagnostics and maintenance alerts. Device enables telematics services through Ford or authorized providers. Activate at <a href="http://www.fleet.ford.com">www.fleet.ford.com</a> or call 833-FCS-FORD or 833-327-3673. Includes a complimentary trial subscription of 3 months or 3 gigabytes whichever comes first, wireless service plan required after trial subscription ends. Visit <a href="http://att.com/ford">att.com/ford</a> to start complimentary trial and sign up for a wireless service plan.</p>
17C	<p><b>SYNC</b> Includes enhanced voice recognition communications and entertainment system, 911 assist, 4.2" LCD display in center stack, Applink and 1 smart charging USB port.</p>
50S	<p><b>Front &amp; Rear Chrome Bumpers</b></p>
<b>Emissions</b>	<p>Includes body-color front fascia.</p>
422	<p><b>Cruise Control</b></p>
93N	<p><b>California Emissions System</b> Required code for California Emissions States registration. Optional code for Cross Border State dealers (Arizona, District of Columbia, Idaho, New Hampshire, Nevada, Ohio, Virginia and West Virginia).</p>
	<p><b>Dealer Order For California States Registration</b></p>
	<p>Not available for stock orders. Federal Emissions state dealers ordering a California Emissions system (422) are also required to use order code 93N to attest that the vehicle is to be registered in a California Emissions state. Note: It is a violation of federal law for a Federal Emissions state dealer to sell a vehicle with a California Emissions system for registration in a Federal Emissions state, unless the vehicle also meets EPA standards (i.e. 50-state emissions).</p>

2020 Ford F 150 crew cab, this is based on a factory order.

\$25,533.41  
\$ 8.75 Tire Fee  
\$ 9.50 CVR  
\$ 1,978.84 7.75% Sales Tax  
\$27,530.50

Thank you,

Vikiy Garay  
Fritts Ford



Prepared by: Vikiy Garay  
11/27/2019

Fritts Ford | 8000 Auto Drive Riverside California | 925044193

2020 F-350 Chassis 4x4 SD Crew Cab 179" WB SRW XL (W3F)

Price Level: 20

As Configured Vehicle

Code	Description
<b>Base Vehicle</b>	
W3F	Base Vehicle Price (W3F)
<b>Packages</b>	
630A	Order Code 630A Includes: - Engine: 6.2L 2-Valve SOHC EFI NA V8 (Flex-Fuel) - Transmission: TorqShift 10-Speed Automatic Includes selectable drive modes: normal, tow/haul, eco and deep sand/snow. - 3.73 Axle Ratio - GVWR: 11,400 lb Payload Package - Tires: LT275/65Rx18E BSW A/S - Wheels: 18" Argent Painted Steel Includes painted hub covers/center ornaments. - HD Vinyl 40/20/40 Split Bench Seat Includes center armrest, cupholder, storage and driver's side manual lumbar. - Radio: AM/FM Stereo w/MP3 Player Includes 6 speakers. - SYNC Communications & Entertainment System Includes enhanced voice recognition, 911 Assist, 4.2" LCD center stack screen, AppLink, 1 smart-charging USB-C port and steering wheel audio controls.
<b>Powertrain</b>	
996	Engine: 6.2L 2-Valve SOHC EFI NA V8 (Flex-Fuel)
44G	Transmission: TorqShift 10-Speed Automatic Includes selectable drive modes: normal, tow/haul, eco and deep sand/snow.
X37	3.73 Axle Ratio
STDGV	GVWR: 11,400 lb Payload Package Complete restrictions/requirements not available.
<b>Wheels &amp; Tires</b>	
TCH	Tires: LT275/65Rx18E BSW A/S
64F	Wheels: 18" Argent Painted Steel Includes painted hub covers/center ornaments.
512	Spare Tire, Wheel & Jack Required in Rhode Island. Excludes carrier. Includes: - 2-Ton Mechanical Jack

Prices and content availability as shown are subject to change and should be treated as estimates only. Actual base vehicle, package and option pricing may vary from this estimate because of special local pricing, availability of equipment and other factors. Dealer's computer system. See salesperson for the most current information.





Prepared by: Vikiy Garay  
11/27/2019

Fritts Ford | 8000 Auto Drive Riverside California | 925044193

2020 F-350 Chassis 4x4 SD Crew Cab 179" WB SRW XL (W3F)

Price Level: 20

As Configured Vehicle (cont'd)

Code	Description
<b>Seats &amp; Seat Trim</b>	
A	HD Vinyl 40/20/40 Split Bench Seat <i>Includes center armrest, cupholder, storage and driver's side manual lumbar.</i>
<b>Other Options</b>	
PAINT	Monotone Paint Application
179WB	179" Wheelbase
STDRD	Radio: AM/FM Stereo w/MP3 Player <i>Includes 6 speakers. Includes: - SYNC Communications &amp; Entertainment System Includes enhanced voice recognition, 911 Assist, 4.2" LCD center stack screen, AppLink, 1 smart-charging USB-C port and steering wheel audio controls.</i>
90L	Power Equipment Group <i>Deletes passenger side lock cylinder. Includes upgraded door-trim panel. Includes: - Accessory Delay - Advanced Security Pack Includes SecuriLock Passive Anti-Theft System (PATS) and inclination/intrusion sensors. - Trailer Tow Mirrors w/Power Heated Glass Includes manual telescoping, heated convex spotter mirror and integrated clearance lamps/turn signals. - MyKey Includes owner controls feature. - Power Front &amp; Rear Side Windows Includes 1-touch up/down driver/passenger window. - Power Locks - Remote Keyless Entry</i>
61J	2-Ton Mechanical Jack Required in Rhode Island.
52B	Trailer Brake Controller <i>Includes smart trailer tow connector. Verified to be compatible with electronic actuated drum brakes only.</i>
18B	Platform Running Boards
59H	Center High-Mounted Stop Lamp (CHMSL)
<b>Fleet Options</b>	
17F	XL Decor Group (LPO) Requires valid FIN code.

Prices and content availability as shown are subject to change and should be treated as estimates only. Actual base vehicle, package and option pricing may vary from this estimate because of special local pricing, availability of equipment and other factors. Dealer's computer system. See salesperson for the most current information.



Prepared by: Vikiy Garay  
11/27/2019

Fritts Ford | 8000 Auto Drive Riverside California | 925044193

2020 F-350 Chassis 4x4 SD Crew Cab 179" WB SRW XL (W3F)

Price Level: 20

As Configured Vehicle (cont'd)

Code	Description
96V_	<i>Includes:</i> - Bright Chrome Hub Covers & Center Ornaments - Chrome Front Bumper  XL Value Package (Fleet)  <i>Includes:</i> - XL Decor Group (LPO) - Bright Chrome Hub Covers & Center Ornaments - Chrome Front Bumper - Steering Wheel-Mounted Cruise Control

Emissions

425	50-State Emissions System
-----	---------------------------

Interior Colors

AS_01	Medium Earth Gray
-------	-------------------

Primary Colors

Z1_01	Oxford White
-------	--------------

2020 Ford F 350 Crew Cab, single Rear Wheel with Harbor Utility Body. This is based on a factory order.

\$43,816.22  
 \$ 8.75 Tire Fee  
 \$ 9.50 CVR  
 \$ 3,395.78 7.75% Sales Tax  
 \$47,230.25

Thank you

Vikiy Garay  
 Fritts Ford  
 951-353-8800

**Item Attachment Documents:****12. Approval of Payment for Fire Protection Services**

## Recommended Action:

Approval of payment of first quarter fire protection services to the County in the amount of \$952,444.77.



RIVERSIDE COUNTY FIRE DEPARTMENT  
IN COOPERATION WITH  
THE CALIFORNIA DEPARTMENT OF FORESTRY AND FIRE PROTECTION

12.

**Shawn C. Newman ~ Fire Chief**  
210 West San Jacinto Avenue • Perris, California 92570 • (951) 940-6900  
• Fax (951) 940-6770 • www.rvcfire.org

PROUDLY SERVING THE  
UNINCORPORATED AREAS  
OF RIVERSIDE COUNTY  
AND THE CITIES OF:

- BANNING
- BEAUMONT
- CANYON LAKE
- COACHELLA
- DESERT HOT SPRINGS
- EASTVALE
- INDIAN WELLS
- INDIO
- JURUPA VALLEY
- LAKE ELSINORE
- LA QUINTA
- MENIFEE
- MORENO VALLEY
- NORCO
- PALM DESERT
- PERRIS
- RANCHO MIRAGE
- RUBIDOUX CSD
- SAN JACINTO
- TEMECULA
- WILDOMAR

BOARD OF  
SUPERVISORS:

- KEVIN JEFFRIES  
DISTRICT 1
- KAREN SPIEGEL  
DISTRICT 2
- CHARLES WASHINGTON  
DISTRICT 3
- V. MANUEL PEREZ  
DISTRICT 4
- JEFF HEWITT  
DISTRICT 5

November 18, 2019

City of Beaumont  
Attn: City Manager  
550 E. Sixth Street  
Beaumont, CA 92223

RE: Fire Protection Services  
1<sup>st</sup> Qtr. FY 19/20

Please find enclosed invoice #233444 in the amount of \$952,444.77 for fire protection services provided for the period of July 1, through September 30, 2019. All costs are actual except for the Support Services which is based on your "FY 19/20 Cost Estimate".

Included in this quarter is the HR Overhead Cost, which will now be billed on a quarterly basis. In addition, we have summarized the format of the Non-Safety County Payroll report.

Payments can also be made via Wire Transfer or ACH, information as follows:

Union Bank  
1980 Saturn Street  
Monterey Park, CA 91755  
Account Name: Riverside County Treasurer  
ABA #: 122000496  
Account #: 0050173925

Reference information to be included on check, wire transfer or ACH :

**FPARC – City abbreviation, Invoice #, FY, Q# (ie: FPARC-BM,233444,19/20,Q1)**

If you have any questions regarding this billing, please contact Karen Gipson at (951) 940-6333.

Sincerely,  
Shawn C. Newman  
Riverside County Fire Chief

*Karen Gipson*

by:  
Karen Gipson  
Administrative Services Officer

KG: mrm  
Enclosures

cc: DC Todd Hopkins  
Chief Smith  
Chief Otterman

153

ST 738





# Riverside County Fire Department

210 West San Jacinto Avenue  
 Perris, CA 92570  
 Ph: (951) 940-6900  
 Fx: (951) 657-2662

# Invoice

FIRE PROTECTION SERVICES

12.

Date	Invoice #
11/15/2019	233444
<b>Make Remittance Payable to:</b>	
County of Riverside Fire Department 210 W. San Jacinto Ave. Perris, CA 92570	

City of Beaumont  
 Attn: City Manager  
 550 E. Sixth Street  
 Beaumont, CA 92223

**FIRE PROTECTION SERVICES FURNISHED FOR THE PERIOD OF: JUL - SEP FY 19/20 Q1**

Description	Amount
***** ACTUAL BILLING *****	
SAFETY STAFFING COST INCLUDING BENEFITS (CAL-Fire Employees):	
AO17 for the month of: JULY 2019	179,858.90
AO17 for the month of: AUGUST 2019	176,187.55
AO17 for the month of: SEPTEMBER 2019	142,967.74
Subtotal	499,014.19
State's Administrative Charge Pass Thru: 0.1169	58,334.76
Total Safety Staffing Cost	557,348.95
NON-SAFETY STAFFING COSTS (County Employees):	
For the 1st Qtr - Richard Horner	40,180.94
HR Overhead Charges - Qtr I	332.54
Subtotal	40,513.48
SUPPORT SERVICES (Cooperative Agreement):	
Quarterly Service Delivery Costs (\$780,744.00 Yearly)	195,186.00
Subtotal	195,186.00
FIRE ENGINE USE AGREEMENT:	
Fire Engine - 2 (\$25,800.00 each = \$51,600.00 Yearly)	12,900.00
Subtotal	12,900.00
TAX CREDIT:	
NOT APPLICABLE	0.00
Subtotal	0.00
MISCELLANEOUS COSTS & DIRECT CHARGES:	
Banning - Sta # 20 Cooperative Agreement PCA # 37129	145,220.45
1st Qtr Direct Charges	6,626.95
1st Qtr Direct Journals	0.00
AMR Transport Costs Reimb.: Q1 FY 19/20	-5,351.06
Subtotal	146,496.34
INVOICE SUBTOTAL	952,444.77

**Please Pay this Amount**

**\$952,444.77**

FOR INTERNAL USE ONLY:

27002- \_\_\_\_\_ - \$ \_\_\_\_\_

27004- \_\_\_\_\_ - \$ \_\_\_\_\_

2700200000-230100- \$ \_\_\_\_\_ FP\_HAZMAT\_VEH



AO17

California Department of Forestry and Fire Protection

Billing Period: 7/1/2019

RRU	SOUTHERN REGION	INDEX 3100	PCA 37101	RIVERSIDE COUNTY-BEAUMONT
-----	-----------------	------------	-----------	---------------------------

<b>Gross Expenditures:</b>		\$179,858.90 ✓
<b>Administrative Charge:</b>	.0647	11,636.87
<b>Statewide Pro Rata:</b>	.0522	9,388.63
		<hr/>
<b>GRAND TOTAL:</b>		<b>\$200,884.40</b>

Prepared by: <i>Maria Silva</i>	Date Sent to Accounting:
Approved by: <i>Barry L. Eden</i>	Date: 9/30/2019

Print Date: 09/26/2019 5:04PM Ver 1.8

RRU	SOUTHERN REGION	INDEX 3100	PCA 37101	RIVERSIDE COUNTY-BEAUMONT	12.
-----	-----------------	------------	-----------	---------------------------	-----

**Safety - BU (08)**  
**PERSONNEL SALARIES**

<u>CLASS</u>	<u>SERIAL</u>	<u>NAME</u>	<u>%</u>	<u>SALARY</u>	<u>DAYS</u>	<u>HOURS</u>	<u>AMOUNT</u>
FIRE APPARATUS ENGINEER	201	BALESTRACCI, PIETRO D	100.00	4,342.00	22.00	0.00	4,342.00
FIRE APPARATUS ENGINEER	200	ROHRABAUGH, JOHN R	100.00	4,597.00	22.00	0.00	4,597.00
FIRE APPARATUS ENGINEER (PARAMEDIC)	642	DUTTON, RYAN	100.00	5,325.00	22.00	0.00	5,325.00
FIRE APPARATUS ENGINEER (PARAMEDIC)	646	JUAREZ II, GUADALUPE	100.00	5,325.00	22.00	0.00	5,325.00
FIRE CAPTAIN	624	GHILONI, RICHARD M	100.00	5,822.40	22.00	0.00	5,822.40
FIRE FIGHTER II	281	ALVAREZ, PABLO	100.00	4,484.00	22.00	0.00	4,484.00
FIRE FIGHTER II	762	CLIFFORD, EDDIE D	100.00	4,872.88	22.00	0.00	4,872.88
FIRE FIGHTER II	758	HOLMES, JACOB B	100.00	4,484.00	22.00	0.00	4,484.00
FIRE FIGHTER II (PARAMEDIC)	638	HAYS, DEVON D	100.00	4,872.00	22.00	0.00	4,872.00
FIRE FIGHTER II (PARAMEDIC)	712	MCDERMOTT, KYLE D	100.00	4,797.00	22.00	0.00	4,797.00
FIRE FIGHTER II (PARAMEDIC)	710	MEZA, RENEE	100.00	4,396.00	22.00	0.00	4,396.00
FIRE FIGHTER II (PARAMEDIC)	203	OCONNOR, CHRISTOPHER J	100.00	4,797.00	22.00	0.00	4,797.00
Total:							58,114.28
Staff Benefits 0.9160:							53,232.68
Total with Benefits:							\$111,346.96

RRU	SOUTHERN REGION	INDEX 3100	PCA 37101	RIVERSIDE COUNTY-BEAUMONT	12.
-----	-----------------	------------	-----------	---------------------------	-----

**UNIFORM - SAFETY**

<u>CLASS</u>	<u>NAME</u>	<u>DESCRIPTION</u>	<u>RATE</u>	<u>%</u>	<u>AMOUNT</u>
FIRE APPARATUS ENGINEER	BALESTRACCI, PIETRO D	Permanent Fulltime Wearer	177.50	100.00	177.50
FIRE APPARATUS ENGINEER	ROHRABAUGH, JOHN R	Permanent Fulltime Wearer	177.50	100.00	177.50
FIRE APPARATUS ENGINEER (PARAM	DUTTON, RYAN	Permanent Fulltime Wearer	177.50	100.00	177.50
FIRE APPARATUS ENGINEER (PARAM	JUAREZ II, GUADALUPE	Permanent Fulltime Wearer	177.50	100.00	177.50
FIRE CAPTAIN	GHILONI, RICHARD M	Permanent Fulltime Wearer	177.50	100.00	177.50
FIRE FIGHTER II	ALVAREZ, PABLO	Permanent Fulltime Wearer	177.50	100.00	177.50
FIRE FIGHTER II	CLIFFORD, EDDIE D	Permanent Fulltime Wearer	177.50	100.00	177.50
FIRE FIGHTER II	HOLMES, JACOB B	Permanent Fulltime Wearer	177.50	100.00	177.50
FIRE FIGHTER II (PARAMEDIC)	HAYS, DEVON D	Permanent Fulltime Wearer	177.50	100.00	177.50
FIRE FIGHTER II (PARAMEDIC)	MCDERMOTT, KYLE D	Permanent Fulltime Wearer	177.50	100.00	177.50
FIRE FIGHTER II (PARAMEDIC)	MEZA, RENEE	Permanent Fulltime Wearer	177.50	100.00	177.50
FIRE FIGHTER II (PARAMEDIC)	OCONNOR, CHRISTOPHER J	Permanent Fulltime Wearer	177.50	100.00	177.50
Total:					2,130.00
Staff Benefits :0.0145					30.89
Total with Benefits:					\$2,160.89

RRU	SOUTHERN REGION	INDEX 3100	PCA 37101	RIVERSIDE COUNTY-BEAUMONT	12.
-----	-----------------	------------	-----------	---------------------------	-----

**EXTENDED DUTY WEEK COMP - SAFETY**

<u>CLASS</u>	<u>SERIAL</u>	<u>NAME</u>	<u>WP</u>	<u>SALARY</u>	<u>HOURS</u>	<u>RATE</u>	<u>AMOUNT</u>
FIRE APPARATUS ENGINEER	201	BALESTRACCI, PIETRO D	407	4,342.00	38.00	26.87	1,021.06
FIRE APPARATUS ENGINEER	201	BALESTRACCI, PIETRO D	407	4,226.00	38.00	26.15	993.70
FIRE APPARATUS ENGINEER	200	ROHRABAUGH, JOHN R	407	4,474.00	38.00	27.68	1,051.84
FIRE APPARATUS ENGINEER	200	ROHRABAUGH, JOHN R	407	4,597.00	38.00	28.44	1,080.72
FIRE APPARATUS ENGINEER (PAF	642	DUTTON, RYAN	407	5,682.00	38.00	35.15	1,335.70
FIRE APPARATUS ENGINEER (PAF	642	DUTTON, RYAN	407	5,825.00	38.00	36.50	1,387.00
FIRE APPARATUS ENGINEER (PAF	646	JUAREZ II, GUADALUPE	407	5,682.00	38.00	35.15	1,335.70
FIRE APPARATUS ENGINEER (PAF	646	JUAREZ II, GUADALUPE	407	5,825.00	38.00	36.03	1,369.14
FIRE CAPTAIN	624	GHILONI, RICHARD M	407	5,668.93	38.00	35.07	1,332.66
FIRE CAPTAIN	624	GHILONI, RICHARD M	407	5,822.40	38.00	36.02	1,368.76
FIRE FIGHTER II	281	ALVAREZ, PABLO	407	4,364.00	38.00	27.00	1,026.00
FIRE FIGHTER II	281	ALVAREZ, PABLO	407	4,484.00	38.00	27.74	1,054.12
FIRE FIGHTER II	762	CLIFFORD, EDDIE D	407	4,744.48	38.00	29.36	1,115.68
FIRE FIGHTER II	762	CLIFFORD, EDDIE D	407	4,872.88	38.00	30.15	1,145.70
FIRE FIGHTER II	758	HOLMES, JACOB B	407	4,364.00	38.00	27.00	1,026.00
FIRE FIGHTER II	758	HOLMES, JACOB B	407	4,484.00	38.00	27.74	1,054.12
FIRE FIGHTER II (PARAMEDIC)	638	HAYS, DEVON D	407	5,244.00	38.00	32.45	1,233.10
FIRE FIGHTER II (PARAMEDIC)	638	HAYS, DEVON D	407	5,372.00	38.00	33.23	1,262.74
FIRE FIGHTER II (PARAMEDIC)	712	MCDERMOTT, KYLE D	407	5,236.26	38.00	32.39	1,230.82
FIRE FIGHTER II (PARAMEDIC)	712	MCDERMOTT, KYLE D	407	5,540.26	38.00	34.28	1,302.64
FIRE FIGHTER II (PARAMEDIC)	710	MEZA, RENEE	407	4,933.00	38.00	30.51	1,159.38
FIRE FIGHTER II (PARAMEDIC)	710	MEZA, RENEE	407	5,051.00	38.00	31.25	1,187.50
FIRE FIGHTER II (PARAMEDIC)	203	OCONNOR, CHRISTOPHER J	407	5,019.00	38.00	31.05	1,179.90
FIRE FIGHTER II (PARAMEDIC)	203	OCONNOR, CHRISTOPHER J	407	5,147.00	38.00	31.85	1,210.30
Total:							28,464.28
Staff Benefits .5504:							15,666.74
Total with Benefits:							\$44,131.02

**OVERTIME - SAFETY**

<u>CLASS</u>	<u>SERIAL</u>	<u>NAME</u>	<u>WP</u>	<u>SALARY</u>	<u>HOURS</u>	<u>RATE</u>	<u>AMOUNT</u>
FIRE APPARATUS ENGINEER	797	GARCIA, ALEXANDER	407	5,299.00	24.00	32.78	786.72
FIRE APPARATUS ENGINEER	626	MINOR, BRETT L	407	4,916.00	48.00	30.41	1,459.68
FIRE APPARATUS ENGINEER	693	OCONNELL, DAVID A	407	5,049.00	24.00	31.23	749.52
FIRE APPARATUS ENGINEER	200	ROHRABAUGH, JOHN R	407	4,474.00	2.25	27.68	62.28
FIRE APPARATUS ENGINEER	200	ROHRABAUGH, JOHN R	407	4,597.00	24.00	28.44	682.56
FIRE APPARATUS ENGINEER (PAF	642	DUTTON, RYAN	407	5,825.00	3.00	36.50	109.50
FIRE APPARATUS ENGINEER (PAF	646	JUAREZ II, GUADALUPE	407	5,682.00	24.00	35.15	843.60

RRU	SOUTHERN REGION	INDEX 3100	PCA 37101	RIVERSIDE COUNTY-BEAUMONT	12.
-----	-----------------	------------	-----------	---------------------------	-----

**OVERTIME - SAFETY**

<u>CLASS</u>	<u>SERIAL</u>	<u>NAME</u>	<u>WP</u>	<u>SALARY</u>	<u>HOURS</u>	<u>RATE</u>	<u>AMOUNT</u>
FIRE APPARATUS ENGINEER (PAF)	646	JUAREZ II, GUADALUPE	407	5,825.00	72.00	36.03	2,594.16
FIRE APPARATUS ENGINEER (PAF)	662	MUSSELMAN, ROBERT A	407	6,050.00	24.00	37.43	898.32
FIRE CAPTAIN	203	MECKELBORG, IAN A	407	5,710.80	24.00	35.33	847.92
FIRE CAPTAIN	636	PARKER, DANIEL W	407	5,661.00	44.00	35.03	1,541.32
FIRE CAPTAIN (PARAMEDIC)	625	DAVIS, KRISTOFER L	407	6,512.00	24.00	40.29	966.96
FIRE FIGHTER II	281	ALVAREZ, PABLO	407	4,364.00	72.00	27.00	1,944.00
FIRE FIGHTER II	758	HOLMES, JACOB B	407	4,484.00	1.50	27.74	41.61
FIRE FIGHTER II	782	LABBEE, CHRISTIAN W	407	4,484.00	24.00	27.74	665.76
FIRE FIGHTER II (PARAMEDIC)	638	HAYS, DEVON D	407	5,244.00	46.75	32.45	1,517.04
FIRE FIGHTER II (PARAMEDIC)	712	MCDERMOTT, KYLE D	407	5,236.26	24.00	32.39	777.36
FIRE FIGHTER II (PARAMEDIC)	712	MCDERMOTT, KYLE D	407	5,540.26	25.50	34.28	874.14
FIRE FIGHTER II (PARAMEDIC)	710	MEZA, RENEE	407	4,933.00	28.00	30.51	854.28
FIRE FIGHTER II (PARAMEDIC)	203	OCONNOR, CHRISTOPHER J	407	5,019.00	48.00	31.05	1,490.40
FIRE FIGHTER II (PARAMEDIC)	203	OCONNOR, CHRISTOPHER J	407	5,147.00	49.00	31.85	1,560.65
FIRE FIGHTER II (PARAMEDIC)	657	WILLIMAN, BRIAN D	407	3,946.00	26.00	24.41	634.66
						Total:	21,902.44
						Staff Benefits .0145:	317.59
						Total with Benefits:	\$22,220.03





AO17

California Department of Forestry and Fire Protection

Billing Period: 8/1/2019

RRU	SOUTHERN REGION	INDEX 3100	PCA 37101	RIVERSIDE COUNTY-BEAUMONT
-----	-----------------	------------	-----------	---------------------------

Gross Expenditures: \$176,187.55 ✓

Administrative Charge: .0647 11,399.33

Statewide Pro Rata: .0522 9,196.99

GRAND TOTAL: \$196,783.87

Prepared by: <i>Maria Silva</i>	Date Sent to Accounting:
Approved by: <i>Samuel Owen</i>	Date: 9/30/2019

Print Date: 09/27/2019 11:25AM Ver 1.8



RRU	SOUTHERN REGION	INDEX 3100	PCA 37101	RIVERSIDE COUNTY-BEAUMONT	12.
-----	-----------------	------------	-----------	---------------------------	-----

**Safety - BU (08)**  
**PERSONNEL SALARIES**

<u>CLASS</u>	<u>SERIAL</u>	<u>NAME</u>	<u>%</u>	<u>SALARY</u>	<u>DAYS</u>	<u>HOURS</u>	<u>AMOUNT</u>
FIRE APPARATUS ENGINEER	201	BALESTRACCI, PIETRO D	100.00	4,342.00	22.00	0.00	4,342.00
FIRE APPARATUS ENGINEER	200	ROHRABAUGH, JOHN R	100.00	4,597.00	22.00	0.00	4,597.00
FIRE APPARATUS ENGINEER (PARAME	642	DUTTON, RYAN	100.00	5,325.00	22.00	0.00	5,325.00
FIRE APPARATUS ENGINEER (PARAME	646	JUAREZ II, GUADALUPE	100.00	5,325.00	22.00	0.00	5,325.00
FIRE CAPTAIN	624	GHILONI, RICHARD M	100.00	5,822.40	22.00	0.00	5,822.40
FIRE FIGHTER II	281	ALVAREZ, PABLO	100.00	4,484.00	8.00	0.00	1,630.55
FIRE FIGHTER II	762	CLIFFORD, EDDIE D	100.00	4,872.88	22.00	0.00	4,872.88
FIRE FIGHTER II	758	HOLMES, JACOB B	100.00	4,484.00	22.00	0.00	4,484.00
FIRE FIGHTER II (PARAMEDIC)	638	HAYS, DEVON D	100.00	4,872.00	22.00	0.00	4,872.00
FIRE FIGHTER II (PARAMEDIC)	712	MCDERMOTT, KYLE D	100.00	4,797.00	8.00	0.00	1,744.36
FIRE FIGHTER II (PARAMEDIC)	710	MEZA, RENEE	100.00	4,396.00	22.00	0.00	4,396.00
FIRE FIGHTER II (PARAMEDIC)	203	OCONNOR, CHRISTOPHER J	100.00	4,797.00	22.00	0.00	4,797.00
Total:							52,208.19
Staff Benefits 0.9160:							47,822.70
Total with Benefits:							\$100,030.89

RRU	SOUTHERN REGION	INDEX 3100	PCA 37101	RIVERSIDE COUNTY-BEAUMONT	12.
-----	-----------------	------------	-----------	---------------------------	-----

**UNIFORM - SAFETY**

<u>CLASS</u>	<u>NAME</u>	<u>DESCRIPTION</u>	<u>RATE</u>	<u>%</u>	<u>AMOUNT</u>
FIRE APPARATUS ENGINEER	BALESTRACCI, PIETRO D	Permanent Fulltime Wearer	177.50	100.00	177.50
FIRE APPARATUS ENGINEER	ROHRABAUGH, JOHN R	Permanent Fulltime Wearer	177.50	100.00	177.50
FIRE APPARATUS ENGINEER (PARAM	DUTTON, RYAN	Permanent Fulltime Wearer	177.50	100.00	177.50
FIRE APPARATUS ENGINEER (PARAM	JUAREZ II, GUADALUPE	Permanent Fulltime Wearer	177.50	100.00	177.50
FIRE CAPTAIN	GHILONI, RICHARD M	Permanent Fulltime Wearer	177.50	100.00	177.50
FIRE FIGHTER II	CLIFFORD, EDDIE D	Permanent Fulltime Wearer	177.50	100.00	177.50
FIRE FIGHTER II	HOLMES, JACOB B	Permanent Fulltime Wearer	177.50	100.00	177.50
FIRE FIGHTER II (PARAMEDIC)	HAYS, DEVON D	Permanent Fulltime Wearer	177.50	100.00	177.50
FIRE FIGHTER II (PARAMEDIC)	MEZA, RENEE	Permanent Fulltime Wearer	177.50	100.00	177.50
FIRE FIGHTER II (PARAMEDIC)	OCONNOR, CHRISTOPHER J	Permanent Fulltime Wearer	177.50	100.00	177.50
Total:					1,775.00
Staff Benefits :0.0145					25.74
Total with Benefits:					\$1,800.74

RRU	SOUTHERN REGION	INDEX 3100	PCA 37101	RIVERSIDE COUNTY-BEAUMONT	12.
-----	-----------------	------------	-----------	---------------------------	-----

**EXTENDED DUTY WEEK COMP - SAFETY**

<u>CLASS</u>	<u>SERIAL</u>	<u>NAME</u>	<u>WP</u>	<u>SALARY</u>	<u>HOURS</u>	<u>RATE</u>	<u>AMOUNT</u>
FIRE APPARATUS ENGINEER	201	BALESTRACCI, PIETRO D	408	4,342.00	76.00	26.87	2,042.12
FIRE APPARATUS ENGINEER	200	ROHRABAUGH, JOHN R	408	4,597.00	76.00	28.44	2,161.44
FIRE APPARATUS ENGINEER (PAF)	642	DUTTON, RYAN	408	5,825.00	76.00	36.50	2,774.00
FIRE APPARATUS ENGINEER (PAF)	646	JUAREZ II, GUADALUPE	408	5,825.00	76.00	36.03	2,738.28
FIRE CAPTAIN	624	GHILONI, RICHARD M	408	5,822.40	76.00	36.02	2,737.52
FIRE FIGHTER II	281	ALVAREZ, PABLO	408	4,484.00	76.00	27.74	2,108.24
FIRE FIGHTER II	762	CLIFFORD, EDDIE D	408	4,872.88	76.00	30.15	2,291.40
FIRE FIGHTER II	758	HOLMES, JACOB B	408	4,484.00	76.00	27.74	2,108.24
FIRE FIGHTER II (PARAMEDIC)	638	HAYS, DEVON D	408	5,372.00	76.00	33.23	2,525.48
FIRE FIGHTER II (PARAMEDIC)	712	MCDERMOTT, KYLE D	408	5,540.26	76.00	34.28	2,605.28
FIRE FIGHTER II (PARAMEDIC)	710	MEZA, RENEE	408	5,051.00	76.00	31.25	2,375.00
FIRE FIGHTER II (PARAMEDIC)	203	OCONNOR, CHRISTOPHER J	408	5,147.00	76.00	31.85	2,420.60
Total:							28,887.60
Staff Benefits .5504:							15,899.74
Total with Benefits:							\$44,787.34

**OVERTIME - SAFETY**

<u>CLASS</u>	<u>SERIAL</u>	<u>NAME</u>	<u>WP</u>	<u>SALARY</u>	<u>HOURS</u>	<u>RATE</u>	<u>AMOUNT</u>
FIRE APPARATUS ENGINEER	201	BALESTRACCI, PIETRO D	408	4,342.00	121.00	26.87	3,251.27
FIRE APPARATUS ENGINEER	688	ESTRADA, HUMBERTO M	408	4,783.00	24.00	29.60	710.40
FIRE APPARATUS ENGINEER	745	JOHNSON, LAWRENCE C	408	5,049.00	24.00	31.23	749.52
FIRE APPARATUS ENGINEER	729	MAGANA, JAMES M	408	4,338.00	15.75	26.84	422.73
FIRE APPARATUS ENGINEER	626	MINOR, BRETT L	408	5,049.00	24.00	31.23	749.52
FIRE APPARATUS ENGINEER	200	ROHRABAUGH, JOHN R	408	4,597.00	48.00	28.44	1,365.12
FIRE APPARATUS ENGINEER (PAF)	653	CARPENTER, KYLE R	408	5,839.00	24.00	36.12	866.88
FIRE APPARATUS ENGINEER (PAF)	642	DUTTON, RYAN	408	5,825.00	76.00	36.50	2,774.00
FIRE APPARATUS ENGINEER (PAF)	637	JOHNSON, ADAM W	408	5,466.00	22.75	33.81	769.18
FIRE APPARATUS ENGINEER (PAF)	646	JUAREZ II, GUADALUPE	408	5,825.00	24.00	36.03	864.72
FIRE APPARATUS ENGINEER (PAF)	633	KATULS, JUSTIN A	408	5,825.00	24.00	36.03	864.72
FIRE CAPTAIN	624	GHILONI, RICHARD M	408	5,822.40	52.00	36.02	1,873.04
FIRE CAPTAIN	755	HINMAN, JOSHUA A	408	5,805.00	24.00	35.91	861.84
FIRE CAPTAIN (PARAMEDIC)	609	SABA, PAUL J	408	6,435.00	24.00	39.81	955.44
FIRE FIGHTER I	901	SCHWEIZER, ALEXANDER S	408	3,273.00	1.75	20.25	35.44
FIRE FIGHTER II	281	ALVAREZ, PABLO	408	4,484.00	24.00	27.74	665.76
FIRE FIGHTER II	762	CLIFFORD, EDDIE D	408	4,872.88	24.00	30.15	723.60
FIRE FIGHTER II	212	HENDRIX, MICHAEL D	408	4,753.84	24.00	29.42	706.08
FIRE FIGHTER II	782	LABBEE, CHRISTOPHER	408	4,484.00	24.00	27.74	665.76

RRU	SOUTHERN REGION	INDEX 3100	PCA 37101	RIVERSIDE COUNTY-BEAUMONT	12.
-----	-----------------	------------	-----------	---------------------------	-----

**OVERTIME - SAFETY**

<u>CLASS</u>	<u>SERIAL</u>	<u>NAME</u>	<u>WP</u>	<u>SALARY</u>	<u>HOURS</u>	<u>RATE</u>	<u>AMOUNT</u>
FIRE FIGHTER II	761	MORGAN, ALADDIN K	408	4,484.00	24.00	27.74	665.76
FIRE FIGHTER II (PARAMEDIC)	650	CARR, JEREMY K	408	4,288.00	48.00	26.52	1,272.96
FIRE FIGHTER II (PARAMEDIC)	638	HAYS, DEVON D	408	5,372.00	72.00	33.23	2,392.56
FIRE FIGHTER II (PARAMEDIC)	712	MCDERMOTT, KYLE D	408	5,540.26	99.50	34.28	3,410.86
FIRE FIGHTER II (PARAMEDIC)	203	OCONNOR, CHRISTOPHER J	408	5,147.00	48.00	31.85	1,528.80
						Total:	29,145.96
						Staff Benefits .0145:	422.62
						Total with Benefits:	\$29,568.58

AO17

California Department of Forestry and Fire Protection



Billing Period: 9/1/2019

RRU	SOUTHERN REGION	INDEX 3100	PCA 37101	RIVERSIDE COUNTY-BEAUMONT
-----	-----------------	------------	-----------	---------------------------

Gross Expenditures:		\$142,967.74 ✓
Administrative Charge:	.0647	9,250.01
Statewide Pro Rata:	.0522	7,462.92
<b>GRAND TOTAL:</b>		<b>\$159,680.67</b>

Prepared by: <i>Maria Silva</i>	Date Sent to Accounting:
Approved by: <i>Brian Owen</i>	Date: 10/24/19

Print Date: 10/23/2019 2:03PM Ver 1.8

RRU	SOUTHERN REGION	INDEX 3100	PCA 37101	RIVERSIDE COUNTY-BEAUMONT	12.
-----	-----------------	------------	-----------	---------------------------	-----

**Safety - BU (08)**  
**PERSONNEL SALARIES**

<u>CLASS</u>	<u>SERIAL</u>	<u>NAME</u>	<u>%</u>	<u>SALARY</u>	<u>DAYS</u>	<u>HOURS</u>	<u>AMOUNT</u>
FIRE APPARATUS ENGINEER	201	BALESTRACCI, PIETRO D	100.00	4,342.00	22.00	0.00	4,342.00
FIRE APPARATUS ENGINEER	200	ROHRABAUGH, JOHN R	100.00	4,597.00	22.00	0.00	4,597.00
FIRE APPARATUS ENGINEER (PARAME	642	DUTTON, RYAN	100.00	5,325.00	22.00	0.00	5,325.00
FIRE APPARATUS ENGINEER (PARAME	646	JUAREZ II, GUADALUPE	100.00	5,325.00	22.00	0.00	5,325.00
FIRE CAPTAIN	624	GHILONI, RICHARD M	100.00	5,822.40	22.00	0.00	5,822.40
FIRE FIGHTER II	762	CLIFFORD, EDDIE D	100.00	4,872.88	22.00	0.00	4,872.88
FIRE FIGHTER II	758	HOLMES, JACOB B	100.00	4,484.00	22.00	0.00	4,484.00
FIRE FIGHTER II (PARAMEDIC)	638	HAYS, DEVON D	100.00	4,872.00	22.00	0.00	4,872.00
FIRE FIGHTER II (PARAMEDIC)	710	MEZA, RENEE	100.00	4,396.00	22.00	0.00	4,396.00
FIRE FIGHTER II (PARAMEDIC)	710	MEZA, RENEE	100.00	4,396.00	0.00	0.00	-4,396.00
FIRE FIGHTER II (PARAMEDIC)	203	OCONNOR, CHRISTOPHER J	100.00	4,797.00	22.00	0.00	4,797.00
Total:							44,437.28
Staff Benefits 0.9160:							40,704.55
Total with Benefits:							\$85,141.83

RRU	SOUTHERN REGION	INDEX 3100	PCA 37101	RIVERSIDE COUNTY-BEAUMONT	12.
-----	-----------------	------------	-----------	---------------------------	-----

**UNIFORM - SAFETY**

<u>CLASS</u>	<u>NAME</u>	<u>DESCRIPTION</u>	<u>RATE</u>	<u>%</u>	<u>AMOUNT</u>
FIRE APPARATUS ENGINEER	BALESTRACCI, PIETRO D	Permanent Fulltime Wearer	177.50	100.00	177.50
FIRE APPARATUS ENGINEER	ROHRABAUGH, JOHN R	Permanent Fulltime Wearer	177.50	100.00	177.50
FIRE APPARATUS ENGINEER (PARAM	DUTTON, RYAN	Permanent Fulltime Wearer	177.50	100.00	177.50
FIRE APPARATUS ENGINEER (PARAM	JUAREZ II, GUADALUPE	Permanent Fulltime Wearer	177.50	100.00	177.50
FIRE CAPTAIN	GHILONI, RICHARD M	Permanent Fulltime Wearer	177.50	100.00	177.50
FIRE FIGHTER II	CLIFFORD, EDDIE D	Permanent Fulltime Wearer	177.50	100.00	177.50
FIRE FIGHTER II	HOLMES, JACOB B	Permanent Fulltime Wearer	177.50	100.00	177.50
FIRE FIGHTER II (PARAMEDIC)	HAYS, DEVON D	Permanent Fulltime Wearer	177.50	100.00	177.50
FIRE FIGHTER II (PARAMEDIC)	MEZA, RENEE	Permanent Fulltime Wearer	177.50	100.00	177.50
FIRE FIGHTER II (PARAMEDIC)	OCONNOR, CHRISTOPHER J	Permanent Fulltime Wearer	177.50	100.00	177.50
Total:					1,775.00
Staff Benefits :0.0145					25.74
Total with Benefits:					\$1,800.74



RRU	SOUTHERN REGION	INDEX 3100	PCA 37101	RIVERSIDE COUNTY-BEAUMONT	12.
-----	-----------------	------------	-----------	---------------------------	-----

**EXTENDED DUTY WEEK COMP - SAFETY**

<u>CLASS</u>	<u>SERIAL</u>	<u>NAME</u>	<u>WP</u>	<u>SALARY</u>	<u>HOURS</u>	<u>RATE</u>	<u>AMOUNT</u>	
FIRE APPARATUS ENGINEER	201	BALESTRACCI, PIETRO D	409	4,342.00	76.00	26.87	2,042.12	
FIRE APPARATUS ENGINEER	200	ROHRABAUGH, JOHN R	409	4,597.00	76.00	28.44	2,161.44	
FIRE APPARATUS ENGINEER (PAF)	642	DUTTON, RYAN	409	5,825.00	76.00	36.03	2,738.28	
FIRE APPARATUS ENGINEER (PAF)	646	JUAREZ II, GUADALUPE	409	5,825.00	76.00	36.03	2,738.28	
FIRE CAPTAIN	624	GHILONI, RICHARD M	409	5,822.40	76.00	36.02	2,737.52	
FIRE FIGHTER II	762	CLIFFORD, EDDIE D	409	4,872.88	76.00	30.15	2,291.40	
FIRE FIGHTER II	758	HOLMES, JACOB B	409	4,484.00	76.00	27.74	2,108.24	
FIRE FIGHTER II (PARAMEDIC)	638	HAYS, DEVON D	409	5,372.00	76.00	33.23	2,525.48	
FIRE FIGHTER II (PARAMEDIC)	710	MEZA, RENEE	409	5,051.00	76.00	31.25	2,375.00	
FIRE FIGHTER II (PARAMEDIC)	203	OCONNOR, CHRISTOPHER J	409	5,147.00	76.00	31.85	2,420.60	
Total:								24,138.36
Staff Benefits .5504:								13,285.75
Total with Benefits:								\$37,424.11

**OVERTIME - SAFETY**

<u>CLASS</u>	<u>SERIAL</u>	<u>NAME</u>	<u>WP</u>	<u>SALARY</u>	<u>HOURS</u>	<u>RATE</u>	<u>AMOUNT</u>
FIRE APPARATUS ENGINEER	201	BALESTRACCI, PIETRO D	409	4,342.00	48.00	26.87	1,289.76
FIRE APPARATUS ENGINEER	510	ESPARZA, MICHAEL A	409	5,348.22	24.00	33.09	794.16
FIRE APPARATUS ENGINEER	745	JOHNSON, LAWRENCE C	409	5,049.00	48.00	31.23	1,499.04
FIRE APPARATUS ENGINEER	712	LIEBERUM, CHASE P	409	4,827.67	24.00	29.87	716.88
FIRE APPARATUS ENGINEER	200	ROHRABAUGH, JOHN R	409	4,597.00	48.00	28.44	1,365.12
FIRE APPARATUS ENGINEER	746	VASQUEZ, CARLOS A	409	4,974.00	47.50	30.77	1,461.58
FIRE APPARATUS ENGINEER (PAF)	642	DUTTON, RYAN	409	5,825.00	30.00	36.03	1,080.90
FIRE APPARATUS ENGINEER (PAF)	636	GEBHARDT, JACOB E	409	5,590.00	24.00	34.58	829.92
FIRE APPARATUS ENGINEER (PAF)	646	JUAREZ II, GUADALUPE	409	5,825.00	144.00	36.03	5,188.32
FIRE APPARATUS ENGINEER (PAF)	633	KATULS, JUSTIN A	409	5,825.00	24.00	36.03	864.72
FIRE APPARATUS ENGINEER (PAF)	631	WIER, JEREMY C	409	5,675.00	31.00	35.10	1,088.10
FIRE CAPTAIN	624	GHILONI, RICHARD M	409	5,822.40	56.00	36.02	2,017.12
FIRE FIGHTER II	762	CLIFFORD, EDDIE D	409	4,872.88	16.00	30.15	482.40
FIRE FIGHTER II	758	HOLMES, JACOB B	409	4,484.00	32.00	27.74	887.68
FIRE FIGHTER II	761	MORGAN, ALADDIN K	409	4,484.00	24.00	27.74	665.76
FIRE FIGHTER II	686	VERWIEL, MATTHEW T	409	3,548.00	24.00	21.95	526.80
FIRE FIGHTER II	209	WALDRON, THOMAS R	409	4,484.00	24.00	27.74	665.76
FIRE FIGHTER II	202	WEIDEMANN, KRISTOFER T	409	4,484.00	24.00	27.74	665.76
FIRE FIGHTER II (PARAMEDIC)	638	HAYS, DEVON D	409	5,372.00	50.00	33.23	1,661.50
FIRE FIGHTER II (PARAMEDIC)	203	OCONNOR, CHRISTOPHER J	409	5,147.00	72.00	31.85	2,293.20

RRU	SOUTHERN REGION	INDEX 3100	PCA 37101	RIVERSIDE COUNTY-BEAUMONT	12.
-----	-----------------	------------	-----------	---------------------------	-----

Total: 26,044.48  
Staff Benefits .0145: 377.64  
Total with Benefits: \$26,422.12

RRU	SOUTHERN REGION	INDEX 3100	PCA 37101	RIVERSIDE COUNTY-BEAUMONT	12.
-----	-----------------	------------	-----------	---------------------------	-----

**RETROACTIVE CHARGES**

Safety - 08

**PERSONNEL SALARIES**

<u>CLASS</u>	<u>SERIAL</u>	<u>NAME</u>		<u>%</u>	<u>SALARY</u>	<u>DAYS</u>	<u>HOURS</u>	<u>AMOUNT</u>	
FIRE FIGHTER II (PARAMEDIC)	712	MCDERMOTT, KYLE D	08/01/2019	100.00	4,872.00	0.00	0.00	27.27	
FIRE FIGHTER II (PARAMEDIC)	712	MCDERMOTT, KYLE D	07/01/2019	100.00	4,872.00	0.00	0.00	37.50	
FIRE FIGHTER II (PARAMEDIC)	710	MEZA, RENEE	08/01/2019	100.00	4,396.00	0.00	0.00	-4,196.18	
								Total:	-4,131.41
								Staff Benefits .9160:	-3,784.37
								Total with Benefits:	\$-7,915.78

RRU	SOUTHERN REGION	INDEX 3100	PCA 37101	RIVERSIDE COUNTY-BEAUMONT	12.
-----	-----------------	------------	-----------	---------------------------	-----

**RETROACTIVE CHARGES**

**EXTENDED DUTY WEEK COMP - SAFETY**

<u>CLASS</u>	<u>SERIAL</u>	<u>NAME</u>	<u>WP</u>	<u>SALARY</u>	<u>HOURS</u>	<u>RATE</u>	<u>AMOUNT</u>	
FIRE FIGHTER II (PARAMEDIC)	712	MCDERMOTT, KYLE D	408	5,540.26	70.00	0.46	32.20	
							Total:	32.20
							Staff Benefits .5504:	17.72
							Total with Benefits:	\$49.92

**OVERTIME - SAFETY**

<u>CLASS</u>	<u>SERIAL</u>	<u>NAME</u>	<u>WP</u>	<u>SALARY</u>	<u>HOURS</u>	<u>RATE</u>	<u>AMOUNT</u>	
FIRE FIGHTER II (PARAMEDIC)	712	MCDERMOTT, KYLE D	408	5,540.26	96.00	0.46	44.16	
							Total:	44.16
							Staff Benefits .0145:	0.64
							Total with Benefits:	\$44.80



**FY 19/20 OVERHEAD FOR COUNTY PERSONNEL AND WARRANT SERVICES - BEAUMONT**

	Per Warrant	
ACO Payroll Fee Per Warrant	4.49	
x Total Qtr Warrants	7	
<b>Total Per Warrant</b>	<b>31.43</b>	
Annual Personnel Cost	1,204.42	
÷ Total Personnel	1.00	
<b>Per Personnel Cost</b>	<b>1,204.42</b>	

	No. of Pay Periods	Annual Personnel Count	New Hire Physical
Richard Horner	7	0.27	0
<b>TOTALS</b>	<b>7</b>	<b>0.27</b>	-

	Cost / Warrant	# of Warrants Issued	
Warrant Costs	\$ 4.49	7	31.43

	Yrly Cost / Per Personnel	# of Personnel	Quarterly
Personnel Costs	\$ 1,204.42	1.00	301.11

	Cost / For Physical		
New Hire Physical Costs	\$ 200.00	0	-

**TOTAL PERSONNEL COSTS** **332.54**

The "ACO per Warrant Fee" is actual.

The "ACO Annual Personnel Cost" is calculated based on 173 previous fiscal years total number of Personnel. This amount will be reconciled to actual fiscal year Personnel total in the 4th Qtr Invoice.

**ENGINE 20 STAFFING - PCA# 37129**

Qtr 1

<b>FY 19/20 Banning</b>		
Banning - Sta# 20		
<b>Support Services FY 19/20</b>		
Exh. "A" Administrative Operational	163,208.00	
Medic Program	23,355.00	
Support Services Annual Costs	186,563.00	
Support Services - Quarterly Costs	186,563.00	\$ 46,640.75
Retroactive Charges	\$0.00	\$0.00
July AO-17 PCA37129	127,660.27	
August AO-17 PCA37129	132,102.83	
September AO-17 PCA37129	129,257.50	
<b>Subtotal 1st Qtr (AO-17)</b>		389,020.60
<b>Subtotal 1st Qtr</b>	<b>\$</b>	<b>435,661.35</b>
<b>Breakdown by City</b>		
City of Banning - 1/3rd		\$ 145,220.45
City of Beaumont 1/3rd		\$ 145,220.45
County of Riverside 1/3rd		\$ 145,220.45
Balance	<b>\$</b>	<b>435,661.35</b>

yellow = input



AO17

California Department of Forestry and Fire Protection



Billing Period: 7/1/2019

RRU	SOUTHERN REGION	INDEX 3100	PCA 37129	BANNING WEST STATION 20
-----	-----------------	------------	-----------	-------------------------

Gross Expenditures:		\$114,298.75
Administrative Charge:	.0647	7,395.13
Statewide Pro Rata:	.0522	5,966.39
<b>GRAND TOTAL:</b>		<b>\$127,660.27</b>

Prepared by: <i>Maria Silva</i>	Date Sent to Accounting:
Approved by: <i>Sam L. Owen</i>	Date: <i>9/30/2019</i>

Print Date: 09/26/2019 5:58PM Ver 1.8

RRU	SOUTHERN REGION	INDEX 3100	PCA 37129	BANNING WEST STATION 20	12.
-----	-----------------	------------	-----------	-------------------------	-----

**Safety - BU (08)****PERSONNEL SALARIES**

<u>CLASS</u>	<u>SERIAL</u>	<u>NAME</u>	<u>%</u>	<u>SALARY</u>	<u>DAYS</u>	<u>HOURS</u>	<u>AMOUNT</u>
FIRE APPARATUS ENGINEER	693	OCONELL, DAVID A	100.00	5,049.00	22.00	0.00	5,049.00
FIRE APPARATUS ENGINEER (PARAME	631	WIER, JEREMY C	100.00	5,325.00	22.00	0.00	5,325.00
FIRE CAPTAIN	603	ARIZAGA, MICHAEL L	100.00	5,934.00	22.00	0.00	5,934.00
FIRE FIGHTER II	761	MORGAN, ALADDIN K	100.00	4,484.00	22.00	0.00	4,484.00
FIRE FIGHTER II	739	SILVEIRA, KEITH J	100.00	4,484.00	22.00	0.00	4,484.00
FIRE FIGHTER II (PARAMEDIC)	722	CORLETT, DAVID T	100.00	3,988.00	22.00	0.00	3,988.00
FIRE FIGHTER II (PARAMEDIC)	281	MORRIS, JUSTIN L	100.00	4,797.00	22.00	0.00	4,797.00
Total:							34,061.00
Staff Benefits 0.9160:							31,199.88
Total with Benefits:							\$65,260.88

RRU	SOUTHERN REGION	INDEX 3100	PCA 37129	BANNING WEST STATION 20	12.
-----	-----------------	------------	-----------	-------------------------	-----

**UNIFORM - SAFETY**

<u>CLASS</u>	<u>NAME</u>	<u>DESCRIPTION</u>	<u>RATE</u>	<u>%</u>	<u>AMOUNT</u>
FIRE APPARATUS ENGINEER	OCONNELL, DAVID A	Permanent Fulltime Wearer	177.50	100.00	177.50
FIRE APPARATUS ENGINEER (PARAM	WIER, JEREMY C	Permanent Fulltime Wearer	177.50	100.00	177.50
FIRE CAPTAIN	ARIZAGA, MICHAEL L	Permanent Fulltime Wearer	177.50	100.00	177.50
FIRE FIGHTER II	MORGAN, ALADDIN K	Permanent Fulltime Wearer	177.50	100.00	177.50
FIRE FIGHTER II	SILVEIRA, KEITH J	Permanent Fulltime Wearer	177.50	100.00	177.50
FIRE FIGHTER II (PARAMEDIC)	CORLETT, DAVID T	Permanent Fulltime Wearer	177.50	100.00	177.50
FIRE FIGHTER II (PARAMEDIC)	MORRIS, JUSTIN L	Permanent Fulltime Wearer	177.50	100.00	177.50
Total:					1,242.50
Staff Benefits :0.0145					18.02
Total with Benefits:					\$1,260.52

RRU	SOUTHERN REGION	INDEX 3100	PCA 37129	BANNING WEST STATION 20	12.
-----	-----------------	------------	-----------	-------------------------	-----

**EXTENDED DUTY WEEK COMP - SAFETY**

<u>CLASS</u>	<u>SERIAL</u>	<u>NAME</u>	<u>WP</u>	<u>SALARY</u>	<u>HOURS</u>	<u>RATE</u>	<u>AMOUNT</u>	
FIRE APPARATUS ENGINEER	693	OCONNELL, DAVID A	407	5,049.00	38.00	31.23	1,186.74	
FIRE APPARATUS ENGINEER	693	OCONNELL, DAVID A	407	4,916.00	38.00	30.41	1,155.58	
FIRE APPARATUS ENGINEER (PAF)	631	WIER, JEREMY C	407	5,675.00	38.00	35.10	1,333.80	
FIRE APPARATUS ENGINEER (PAF)	631	WIER, JEREMY C	407	5,532.00	38.00	34.22	1,300.36	
FIRE CAPTAIN	603	ARIZAGA, MICHAEL L	407	5,934.00	38.00	36.71	1,394.98	
FIRE CAPTAIN	603	ARIZAGA, MICHAEL L	407	5,777.55	38.00	35.75	1,358.50	
FIRE FIGHTER II	721	LIEBERUM, CHASE P	407	4,483.67	19.00	27.74	527.06	
FIRE FIGHTER II	761	MORGAN, ALADDIN K	407	4,484.00	38.00	27.74	1,054.12	
FIRE FIGHTER II	761	MORGAN, ALADDIN K	407	4,364.00	38.00	27.00	1,026.00	
FIRE FIGHTER II	739	SILVEIRA, KEITH J	407	4,484.00	38.00	27.74	1,054.12	
FIRE FIGHTER II	739	SILVEIRA, KEITH J	407	4,364.00	38.00	27.00	1,026.00	
FIRE FIGHTER II (PARAMEDIC)	722	CORLETT, DAVID T	407	4,443.00	38.00	27.48	1,044.24	
FIRE FIGHTER II (PARAMEDIC)	722	CORLETT, DAVID T	407	4,336.00	38.00	26.82	1,019.16	
FIRE FIGHTER II (PARAMEDIC)	281	MORRIS, JUSTIN L	407	5,297.00	38.00	32.78	1,245.64	
FIRE FIGHTER II (PARAMEDIC)	281	MORRIS, JUSTIN L	407	4,993.00	38.00	30.89	1,173.82	
Total:								16,900.12
Staff Benefits .5504:								9,301.83
Total with Benefits:								\$26,201.95

**OVERTIME - SAFETY**

<u>CLASS</u>	<u>SERIAL</u>	<u>NAME</u>	<u>WP</u>	<u>SALARY</u>	<u>HOURS</u>	<u>RATE</u>	<u>AMOUNT</u>
FIRE APPARATUS ENGINEER	201	BALESTRACCI, PIETRO D	407	4,226.00	24.00	26.15	627.60
FIRE APPARATUS ENGINEER	510	ESPARZA, MICHAEL A	407	5,162.82	24.00	31.94	766.56
FIRE APPARATUS ENGINEER	745	JOHNSON, LAWRENCE C	407	5,049.00	24.00	31.23	749.52
FIRE APPARATUS ENGINEER	745	JOHNSON, LAWRENCE C	407	4,916.00	24.00	30.41	729.84
FIRE APPARATUS ENGINEER	693	OCONNELL, DAVID A	407	5,049.00	24.00	31.23	749.52
FIRE APPARATUS ENGINEER	200	ROHRABAUGH, JOHN R	407	4,474.00	48.00	27.68	1,328.64
FIRE APPARATUS ENGINEER	746	VASQUEZ, CARLOS A	407	4,974.00	19.50	30.77	600.02
FIRE APPARATUS ENGINEER (PAF)	640	BUCKLEY, SEAN P	407	5,757.00	24.00	35.61	854.64
FIRE APPARATUS ENGINEER (PAF)	650	MURRAY, STEVEN D	407	5,464.00	18.75	33.80	633.75
FIRE CAPTAIN	603	ARIZAGA, MICHAEL L	407	5,777.55	24.00	35.75	858.00
FIRE CAPTAIN	506	POTTER, JOSHUA S	407	5,655.00	72.00	34.98	2,518.56
FIRE CAPTAIN (PARAMEDIC)	605	LANE, ERIC R	407	6,446.13	24.00	39.87	956.88
FIRE FIGHTER II	762	CLIFFORD, EDDIE D	407	4,744.48	25.50	29.36	748.68
FIRE FIGHTER II	758	HOLMES, JACOB B	407	4,364.00	51.00	27.00	1,377.00
FIRE FIGHTER II	721	LIEBERUM, CHASE P	407	4,483.67	14.00	27.74	388.36
FIRE FIGHTER II	701	POSEY, BRETT C	407	4,439.00	24.00	27.47	659.28

RRU	SOUTHERN REGION	INDEX 3100	PCA 37129	BANNING WEST STATION 20	12.
-----	-----------------	------------	-----------	-------------------------	-----

**OVERTIME - SAFETY**

<u>CLASS</u>	<u>SERIAL</u>	<u>NAME</u>	<u>WP</u>	<u>SALARY</u>	<u>HOURS</u>	<u>RATE</u>	<u>AMOUNT</u>
FIRE FIGHTER II	739	SILVEIRA, KEITH J	407	4,484.00	48.00	27.74	1,331.52
FIRE FIGHTER II	209	WALDRON, THOMAS R	407	4,484.00	25.25	27.74	700.44
FIRE FIGHTER II (PARAMEDIC)	650	CARR, JEREMY K	407	3,946.00	24.00	24.41	585.84
FIRE FIGHTER II (PARAMEDIC)	721	LOPEZ, GABRIEL R	407	5,372.00	48.00	33.23	1,595.04
FIRE FIGHTER II (PARAMEDIC)	721	LOPEZ, GABRIEL R	407	5,244.00	24.00	32.45	778.80
FIRE FIGHTER II (PARAMEDIC)	712	MCDERMOTT, KYLE D	407	5,236.26	24.00	32.39	777.36
FIRE FIGHTER II (PARAMEDIC)	281	MORRIS, JUSTIN L	407	4,993.00	6.00	30.89	185.34
FIRE FIGHTER II (PARAMEDIC)	693	TIMBOL, DARYL C	407	5,158.00	24.00	31.91	765.84
Total:							21,267.03
Staff Benefits .0145:							308.37
Total with Benefits:							\$21,575.40



AO17

California Department of Forestry and Fire Protection

Billing Period: 8/1/2019

RRU	SOUTHERN REGION	INDEX 3100	PCA 37129	BANNING WEST STATION 20
-----	-----------------	------------	-----------	-------------------------

Gross Expenditures: \$118,276.33

Administrative Charge: .0647 7,652.48

Statewide Pro Rata: .0522 6,174.02

**GRAND TOTAL: \$132,102.83**

Prepared by: <i>Maria Silva</i>	Date Sent to Accounting:
Approved by: <i>Emily L. Owen</i>	Date: 9/30/2019

Print Date: 09/27/2019 11:44AM Ver 1.8

RRU	SOUTHERN REGION	INDEX 3100	PCA 37129	BANNING WEST STATION 20	12.
-----	-----------------	------------	-----------	-------------------------	-----

**Safety - BU (08)**  
**PERSONNEL SALARIES**

<u>CLASS</u>	<u>SERIAL</u>	<u>NAME</u>	<u>%</u>	<u>SALARY</u>	<u>DAYS</u>	<u>HOURS</u>	<u>AMOUNT</u>
FIRE APPARATUS ENGINEER	693	OCONELL, DAVID A	100.00	5,049.00	22.00	0.00	5,049.00
FIRE APPARATUS ENGINEER (PARAME	631	WIER, JEREMY C	100.00	5,325.00	22.00	0.00	5,325.00
FIRE CAPTAIN	603	ARIZAGA, MICHAEL L	100.00	5,934.00	22.00	0.00	5,934.00
FIRE FIGHTER II	281	ALVAREZ, PABLO	100.00	4,484.00	14.00	0.00	2,853.45
FIRE FIGHTER II	761	MORGAN, ALADDIN K	100.00	4,484.00	22.00	0.00	4,484.00
FIRE FIGHTER II	739	SILVEIRA, KEITH J	100.00	4,484.00	22.00	0.00	4,484.00
FIRE FIGHTER II (PARAMEDIC)	722	CORLETT, DAVID T	100.00	3,988.00	22.00	0.00	3,988.00
FIRE FIGHTER II (PARAMEDIC)	281	MORRIS, JUSTIN L	100.00	4,797.00	22.00	0.00	4,797.00
Total:							36,914.45
Staff Benefits 0.9160:							33,813.64
Total with Benefits:							\$70,728.09



RRU	SOUTHERN REGION	INDEX 3100	PCA 37129	BANNING WEST STATION 20	12.
-----	-----------------	------------	-----------	-------------------------	-----

**UNIFORM - SAFETY**

<u>CLASS</u>	<u>NAME</u>	<u>DESCRIPTION</u>	<u>RATE</u>	<u>%</u>	<u>AMOUNT</u>
FIRE APPARATUS ENGINEER	OCONNELL, DAVID A	Permanent Fulltime Wearer	177.50	100.00	177.50
FIRE APPARATUS ENGINEER (PARAM	WIER, JEREMY C	Permanent Fulltime Wearer	177.50	100.00	177.50
FIRE CAPTAIN	ARIZAGA, MICHAEL L	Permanent Fulltime Wearer	177.50	100.00	177.50
FIRE FIGHTER II	ALVAREZ, PABLO	Permanent Fulltime Wearer	177.50	100.00	177.50
FIRE FIGHTER II	MORGAN, ALADDIN K	Permanent Fulltime Wearer	177.50	100.00	177.50
FIRE FIGHTER II	SILVEIRA, KEITH J	Permanent Fulltime Wearer	177.50	100.00	177.50
FIRE FIGHTER II (PARAMEDIC)	CORLETT, DAVID T	Permanent Fulltime Wearer	177.50	100.00	177.50
FIRE FIGHTER II (PARAMEDIC)	MORRIS, JUSTIN L	Permanent Fulltime Wearer	177.50	100.00	177.50
				Total:	1,420.00
				Staff Benefits :0.0145	20.59
				Total with Benefits:	\$1,440.59

RRU	SOUTHERN REGION	INDEX 3100	PCA 37129	BANNING WEST STATION 20	12.
-----	-----------------	------------	-----------	-------------------------	-----

**EXTENDED DUTY WEEK COMP - SAFETY**

<u>CLASS</u>	<u>SERIAL</u>	<u>NAME</u>	<u>WP</u>	<u>SALARY</u>	<u>HOURS</u>	<u>RATE</u>	<u>AMOUNT</u>
FIRE APPARATUS ENGINEER	693	OCONNELL, DAVID A	408	5,049.00	76.00	31.23	2,373.48
FIRE APPARATUS ENGINEER (PAF	631	WIER, JEREMY C	408	5,675.00	76.00	35.10	2,667.60
FIRE CAPTAIN	603	ARIZAGA, MICHAEL L	408	5,934.00	76.00	36.71	2,789.96
FIRE FIGHTER II	761	MORGAN, ALADDIN K	408	4,484.00	76.00	27.74	2,108.24
FIRE FIGHTER II	739	SILVEIRA, KEITH J	408	4,484.00	76.00	27.74	2,108.24
FIRE FIGHTER II (PARAMEDIC)	722	CORLETT, DAVID T	408	4,443.00	76.00	27.48	2,088.48
FIRE FIGHTER II (PARAMEDIC)	281	MORRIS, JUSTIN L	408	5,297.00	76.00	32.78	2,491.28
Total:							16,627.28
Staff Benefits .5504:							9,151.65
Total with Benefits:							\$25,778.93

**OVERTIME - SAFETY**

<u>CLASS</u>	<u>SERIAL</u>	<u>NAME</u>	<u>WP</u>	<u>SALARY</u>	<u>HOURS</u>	<u>RATE</u>	<u>AMOUNT</u>
FIRE APPARATUS ENGINEER	510	ESPARZA, MICHAEL A	408	5,348.22	48.00	33.09	1,588.32
FIRE APPARATUS ENGINEER	745	JOHNSON, LAWRENCE C	408	5,049.00	28.50	31.23	890.06
FIRE APPARATUS ENGINEER	693	OCONNELL, DAVID A	408	5,049.00	25.00	31.23	780.75
FIRE APPARATUS ENGINEER (PAF	646	JUAREZ II, GUADALUPE	408	5,825.00	24.00	36.03	864.72
FIRE CAPTAIN	507	BERNARDO, EVAN C	408	5,898.26	48.00	36.48	1,751.04
FIRE CAPTAIN	665	VICK, LANDON D	408	5,298.00	48.00	32.78	1,573.44
FIRE FIGHTER II	702	HUDSON, MICHAEL R	408	4,648.68	24.00	28.76	690.24
FIRE FIGHTER II	735	KIRK, THOMAS J	408	4,789.00	9.00	29.63	266.67
FIRE FIGHTER II	782	LABBEE, CHRISTIAN W	408	4,484.00	48.00	27.74	1,331.52
FIRE FIGHTER II	761	MORGAN, ALADDIN K	408	4,484.00	24.00	27.74	665.76
FIRE FIGHTER II	739	SILVEIRA, KEITH J	408	4,484.00	75.75	27.74	2,101.31
FIRE FIGHTER II	202	WEIDEMANN, KRISTOFER T	408	4,484.00	24.00	27.74	665.76
FIRE FIGHTER II	707	ZAVALA, ENRIQUE R	408	4,559.00	24.00	28.20	676.80
FIRE FIGHTER II (PARAMEDIC)	722	CORLETT, DAVID T	408	4,443.00	75.00	27.48	2,061.00
FIRE FIGHTER II (PARAMEDIC)	281	MORRIS, JUSTIN L	408	5,297.00	28.00	32.78	917.84
FIRE FIGHTER II (PARAMEDIC)	203	OCONNOR, CHRISTOPHER J	408	5,147.00	24.00	31.85	764.40
FIRE FIGHTER II (PARAMEDIC)	724	TAYLOR, TRAVIS A	408	4,288.00	39.75	26.52	1,054.17
FIRE FIGHTER II (PARAMEDIC)	657	WILLIMAN, BRIAN D	408	4,288.00	24.00	26.52	636.48
FIRE FIGHTER II (PARAMEDIC)	614	ZELAYA, NESTOR G	408	4,537.00	27.00	28.07	757.89
Total:							20,038.17
Staff Benefits .0145:							290.55
Total with Benefits:							\$20,328.72



AO17

California Department of Forestry and Fire Protection

Billing Period: 9/1/2019

RRU	SOUTHERN REGION	INDEX 3100	PCA 37129	BANNING WEST STATION 20
-----	-----------------	------------	-----------	-------------------------

<b>Gross Expenditures:</b>		\$115,728.81
<b>Administrative Charge:</b>	.0647	7,487.65
<b>Statewide Pro Rata:</b>	.0522	6,041.04
		<hr/>
<b>GRAND TOTAL:</b>		<b>\$129,257.50</b>

Prepared by: <i>Maria Silva</i>	Date Sent to Accounting:
Approved by: <i>Benny Owen</i>	Date: 10/24/2019

Print Date: 10/23/2019 2:15PM Ver 1.8

RRU	SOUTHERN REGION	INDEX 3100	PCA 37129	BANNING WEST STATION 20	12.
-----	-----------------	------------	-----------	-------------------------	-----

**Safety - BU (08)**  
**PERSONNEL SALARIES**

<u>CLASS</u>	<u>SERIAL</u>	<u>NAME</u>	<u>%</u>	<u>SALARY</u>	<u>DAYS</u>	<u>HOURS</u>	<u>AMOUNT</u>
FIRE APPARATUS ENGINEER	693	OCONNELL, DAVID A	100.00	5,049.00	22.00	0.00	5,049.00
FIRE APPARATUS ENGINEER (PARAME	631	WIER, JEREMY C	100.00	5,325.00	22.00	0.00	5,325.00
FIRE APPARATUS ENGINEER (PARAME	631	WIER, JEREMY C	100.00	5,325.00	0.00	0.00	-5,325.00
FIRE CAPTAIN	603	ARIZAGA, MICHAEL L	100.00	5,934.00	22.00	0.00	5,934.00
FIRE FIGHTER II	281	ALVAREZ, PABLO	100.00	4,484.00	22.00	0.00	4,484.00
FIRE FIGHTER II	761	MORGAN, ALADDIN K	100.00	4,484.00	22.00	0.00	4,484.00
FIRE FIGHTER II	739	SILVEIRA, KEITH J	100.00	4,484.00	22.00	0.00	4,484.00
FIRE FIGHTER II (PARAMEDIC)	722	CORLETT, DAVID T	100.00	3,988.00	22.00	0.00	3,988.00
FIRE FIGHTER II (PARAMEDIC)	281	MORRIS, JUSTIN L	100.00	4,797.00	22.00	0.00	4,797.00
						Total:	33,220.00
						Staff Benefits 0.9160:	30,429.52
						Total with Benefits:	\$63,649.52

RRU	SOUTHERN REGION	INDEX 3100	PCA 37129	BANNING WEST STATION 20	12.
-----	-----------------	------------	-----------	-------------------------	-----

**UNIFORM - SAFETY**

<u>CLASS</u>	<u>NAME</u>	<u>DESCRIPTION</u>	<u>RATE</u>	<u>%</u>	<u>AMOUNT</u>
FIRE APPARATUS ENGINEER	OCONNELL, DAVID A	Permanent Fulltime Wearer	177.50	100.00	177.50
FIRE APPARATUS ENGINEER (PARAM	WIER, JEREMY C	Permanent Fulltime Wearer	177.50	100.00	177.50
FIRE CAPTAIN	ARIZAGA, MICHAEL L	Permanent Fulltime Wearer	177.50	100.00	177.50
FIRE FIGHTER II	ALVAREZ, PABLO	Permanent Fulltime Wearer	177.50	100.00	177.50
FIRE FIGHTER II	MORGAN, ALADDIN K	Permanent Fulltime Wearer	177.50	100.00	177.50
FIRE FIGHTER II	SILVEIRA, KEITH J	Permanent Fulltime Wearer	177.50	100.00	177.50
FIRE FIGHTER II (PARAMEDIC)	CORLETT, DAVID T	Permanent Fulltime Wearer	177.50	100.00	177.50
FIRE FIGHTER II (PARAMEDIC)	MORRIS, JUSTIN L	Permanent Fulltime Wearer	177.50	100.00	177.50
				Total:	1,420.00
				Staff Benefits :0.0145	20.59
				Total with Benefits:	\$1,440.59

RRU	SOUTHERN REGION	INDEX 3100	PCA 37129	BANNING WEST STATION 20	12.
-----	-----------------	------------	-----------	-------------------------	-----

**EXTENDED DUTY WEEK COMP - SAFETY**

<u>CLASS</u>	<u>SERIAL</u>	<u>NAME</u>	<u>WP</u>	<u>SALARY</u>	<u>HOURS</u>	<u>RATE</u>	<u>AMOUNT</u>
FIRE APPARATUS ENGINEER	693	OCONNELL, DAVID A	409	5,049.00	76.00	31.23	2,373.48
FIRE APPARATUS ENGINEER (PAF)	631	WIER, JEREMY C	409	5,675.00	49.00	35.10	1,719.90
FIRE APPARATUS ENGINEER (PAF)	631	WIER, JEREMY C	409	5,825.00	27.00	36.03	972.81
FIRE CAPTAIN	603	ARIZAGA, MICHAEL L	409	5,934.00	76.00	36.71	2,789.96
FIRE FIGHTER II	281	ALVAREZ, PABLO	409	4,484.00	76.00	27.74	2,108.24
FIRE FIGHTER II	761	MORGAN, ALADDIN K	409	4,484.00	76.00	27.74	2,108.24
FIRE FIGHTER II	739	SILVEIRA, KEITH J	409	4,484.00	76.00	27.74	2,108.24
FIRE FIGHTER II (PARAMEDIC)	722	CORLETT, DAVID T	409	4,443.00	76.00	27.48	2,088.48
FIRE FIGHTER II (PARAMEDIC)	281	MORRIS, JUSTIN L	409	5,297.00	76.00	32.78	2,491.28
Total:							18,760.63
Staff Benefits .5504:							10,325.85
Total with Benefits:							\$29,086.48

**OVERTIME - SAFETY**

<u>CLASS</u>	<u>SERIAL</u>	<u>NAME</u>	<u>WP</u>	<u>SALARY</u>	<u>HOURS</u>	<u>RATE</u>	<u>AMOUNT</u>
FIRE APPARATUS ENGINEER	705	REILLY, JOSEPH E	409	5,129.00	48.00	31.73	1,523.04
FIRE APPARATUS ENGINEER	624	RYE, TRAVIS J	409	5,098.74	72.00	31.55	2,271.60
FIRE APPARATUS ENGINEER (PAF)	646	JUAREZ II, GUADALUPE	409	5,825.00	48.00	36.03	1,729.44
FIRE APPARATUS ENGINEER (PAF)	650	MURRAY, STEVEN D	409	5,464.00	24.00	33.80	811.20
FIRE APPARATUS ENGINEER (PAF)	635	SEASE, ROBYN M	409	5,798.00	24.00	35.87	860.88
FIRE APPARATUS ENGINEER (PAF)	631	WIER, JEREMY C	409	5,675.00	72.00	35.10	2,527.20
FIRE CAPTAIN	603	ARIZAGA, MICHAEL L	409	5,934.00	7.00	36.71	256.97
FIRE CAPTAIN	624	GHILONI, RICHARD M	409	5,822.40	24.00	36.02	864.48
FIRE CAPTAIN	645	ORTON JR, MICHAEL S	409	5,710.80	24.00	35.33	847.92
FIRE CAPTAIN	698	WILLIAMS, KEVIN M	409	5,350.23	24.00	33.09	794.16
FIRE FIGHTER II	762	CLIFFORD, EDDIE D	409	4,872.88	24.00	30.15	723.60
FIRE FIGHTER II	761	MORGAN, ALADDIN K	409	4,484.00	24.00	27.74	665.76
FIRE FIGHTER II	739	SILVEIRA, KEITH J	409	4,484.00	54.00	27.74	1,497.96
FIRE FIGHTER II	202	WEIDEMANN, KRISTOFER T	409	4,484.00	24.00	27.74	665.76
FIRE FIGHTER II (PARAMEDIC)	211	BAZACAS, SEAN S	409	4,288.00	48.00	26.52	1,272.96
FIRE FIGHTER II (PARAMEDIC)	281	MORRIS, JUSTIN L	409	5,297.00	72.00	32.78	2,360.16
FIRE FIGHTER II (PARAMEDIC)	724	TAYLOR, TRAVIS A	409	4,288.00	24.00	26.52	636.48
Total:							20,309.57
Staff Benefits .0145:							294.49
Total with Benefits:							\$20,604.06

RRU	SOUTHERN REGION	INDEX 3100	PCA 37129	BANNING WEST STATION 20	12.
-----	-----------------	------------	-----------	-------------------------	-----

**OPERATING EXPENSES AND EQUIPMENT**

	<u>CATEGORY</u>	<u>REMARKS</u>	<u>RATE</u>	<u>%</u>	<u>AMOUNT</u>
ADMIN	TRAVEL	SEE EXPENDITURE REPORT	948.16	100.00	948.16
				Total:	<u>\$948.16</u>



Svc Loc	PO No.	Invoice Number	Acctg Date	Supplier Name		12.	Amount
37129		TEA002557512	7/8/2019	JEREMY C WIER			0.00
37129		TEA002643338	7/12/2019	BRIAN K BLACK			\$536.92
37129		TEA002643338	7/12/2019	BRIAN K BLACK			\$111.24
37129		TEA002590994	7/18/2019	BRIAN K BLACK			\$150.00
							<b>\$948.16</b>

FY 19/20 EXPENDITURES

Item	Sum Amount	Name	Descr	Invoice No
11.46		US Bank National Association	CREDIT CARD PURCHASES FOR AUTO	869015966930
247.89		US Bank National Association	CREDIT CARD PURCHASES FOR DIES	869015966930
232.04		US Bank National Association	CREDIT CARD PURCHASES FOR DIES	869015966934
26.82		Verizon Wireless	VZW Acct.# 271365173-00001	9829828871
26.82		Verizon Wireless	VZW Acct.# 271365173-00001	9831805056
29.63		Verizon Wireless	VZW-ACCT.# -00001 - JULY.2019	9833777624
27.13		Verizon Wireless	VZW-ACCT.# -00001 - AUG.2019	9835765376
396.20		Zoll Medical Corporation	PART# 8900-0400 CPR stat padz	2849829
138.61		Zoll Medical Corporation	PART# 8900-0004 Four (4) pack	2900874
58.99		Zoll Medical Corporation	PART # 8900-0402 - CPR stat;pa	2900874
16.98		Zoll Medical Corporation	PART# 8000-000901-01 X-Series	2901828
180.48		Zoll Medical Corporation	PART # 8300-0002-01 - Dual Lum	2901828
113.72		Zoll Medical Corporation	PART # REUSE-12-2MQ - Cuff, Lg	2901828
84.90		Zoll Medical Corporation	PART# 8900-0006 Six (6) ECG el	2908479
	6,626.95			

6,626.95
6,626.95

35.47 Riverside Rubber Stamp and Engraving HORNER - CITY OF BEAUMONT 19-99472

FY 19/20 EXPENDITURES

Item Amount	Name	Descr	Invoice No
631.44	AT&T	AT&T BIG BILL FY 18-19	000013122780
639.76	AT&T	AT&T BIG BILL FY 19-20	000013404196
631.44	AT&T	AT&T BIG BILL FY 19-20	000013249384
639.76	AT&T	AT&T BIG BILL FY 19-20	000013549687
150.72	Beaumont Do It Best Home Center	FS#66 STATION SUPPLIES	473855
70.71	Beaumont Do It Best Home Center	FS#66 STATION SUPPLIES	473638
67.82	Beaumont Do It Best Home Center	FS#66 STATION SUPPLIES	474685
59.28	Frontier	LANDLINE SERVICE FS#66	951-845-3718-041477-5
45.92	Frontier	LANDLINE SERVICE FS#66	951-845-3718-041477-5
7.37	Life Assist	ALS, FIRST AID AND SAFETY MEDI	926681
(0.14)	Life Assist	Discount Earned	926681
0.14	Life Assist	Discount Earned Memo	926681
9.25	Life Assist	NON EXPENDABLE, FIRST AID AND	927958
9.25	Life Assist	NON EXPENDABLE, FIRST AID AND	928006
21.54	Life Assist	NON EXPENDABLE, FIRST AID AND	928571
259.00	Life Assist	NON EXPENDABLE, FIRST AID AND	931499
56.58	Life Assist	ALS, FIRST AID AND SAFETY MEDI	931499
78.60	Life Assist	NON EXPENDABLE, FIRST AID AND	936056
175.24	Life Assist	NON EXPENDABLE, FIRST AID AND	938777
726.38	Life Assist	ALS, FIRST AID AND SAFETY MEDI	938777
2.37	Qwest Communications Co	Long distance carrier	1470507083
2.59	Qwest Communications Co	Long distance carrier	1472518997
4.47	Qwest Communications Co	Long distance carrier	1474682018
4.45	Qwest Communications Co	Long distance carrier	1476661076
37.99	Sprint	SPRINT-DC ACCT.# 976398813	976398813-137
37.99	Sprint	SPRINT-DC ACCT.# 976398813	976398813-138
97.56	Sprint	SPRINT WRLSS Acct.# 538375318	538375318-210
101.90	Sprint	SPRINT WRLSS Acct.# 538375318	538375318-211
37.99	Sprint	JUNE2019-SPRINT D.C.-ACCT.#976	976398813-139
37.99	Sprint	JULY2019-SPRINT D.C.-ACCT.#976	976398813-140
37.99	Sprint	AUG.2019-SPRINT D.C.-ACCT.#976	976398813-141
95.72	Sprint	JULY2019-SPRINTWRLSS-ACCT.#538	538375318-212
103.32	Sprint	AUG.2019-SPRINTWRLSS-ACCT.#538	538375318-213
152.89	US Bank National Association	CREDIT CARD PURCHASES FOR DIES	869015966926

INVOICE NUMBER: 538375318-210-213

SPRINT WIRELESS - ACCT.# 538375318

BILL TO	DEPT ID	ASSIGNED TO	PHONE NUMBER	329570	329572	333057	333058	Total
	2700403660	E266 - DURA XT	951-232-4271	25.03	25.00	25.31	25.31	50.73
		E66 CELLPHONE	951-906-9155	72.53	76.90	70.41	78.01	135.33
	2700403660	Total		97.56	101.90	95.72	103.32	186.06
Grand Total - BEAUMONT				97.56	101.90	95.72	103.32	186.06

## Actual AMR Transport cost Reimbursement for FY19/20

Q1 Jul - Sep 2019

Agency	Incident Count	Percentage	Pmt Breakdown
Banning	-730	3.17%	(7,311.58)
<b>Beaumont</b>	<b>-534</b>	<b>2.32%</b>	<b>(5,351.06)</b>
Coachella	-384	1.67%	(3,851.84)
Desert Hot Springs	-299	1.30%	(2,998.44)
Eastvale	-608	2.64%	(6,089.14)
La Quinta	-578	2.51%	(5,789.30)
Lake Elsinore	-990	4.30%	(9,917.92)
Menifee	-1,883	8.18%	(18,867.12)
Moreno Valley	-3,225	14.01%	(32,313.97)
Norco	-421	1.83%	(4,220.88)
Perris	-1,275	5.54%	(12,777.97)
Rubidoux	-437	1.90%	(4,382.34)
Riverside County	-8,407	36.52%	(84,233.14)
San Jacinto	-1,045	4.54%	(10,471.48)
Temecula	-1,772	7.70%	(17,760.00)
Wildomar	-430	1.87%	(4,313.14)
<b>Total</b>	<b>-23,019</b>	<b>100.00%</b>	<b>(230,649.33)</b>

\$ **(146,416.19) Contract City CREDIT allocation (2700400000)**

\$ (84,233.14) Riverside County (2700234010)

\$ (230,649.33)

Date Prepared: 11/12/2019

City allocation provided by Jennifer Veik.

NOTE: Enter Percentage only.

COST ESTIMATE

FOR THE CITY OF BEAUMONT  
DATED OCTOBER 8, 2019 FOR FY2019/2020

CITY BUDGETED EXHIBIT "A" ESTIMATE

FISCAL YEAR 2019/2020

TOTAL CITY BUDGET ESTIMATE FOR FY2019/2020

\$4,416,365

\$4,416,365

COST ESTIMATE

FOR THE CITY OF BEAUMONT  
 DATED OCTOBER 8, 2019 FOR FY 2019/2020

Removed Fleet Support cost for Squad 66 per email from City dated 05/13/2019

\*See notation below for estimate assumptions

STA #66	CAPTAIN'S	CAPTAIN'S MEDICS	ENGINEERS	ENGINEER MEDICS	FF I/IS	FF II MEDICS	TOTALS					
Medic Engine	240,547	1	211,087	1	241,591	1	545,971	3	418,930	2	1,658,125	8
Medic Squad			422,174	2	241,591	1			418,930	2	1,082,695	5
<b>SUBTOTALS</b>	<b>240,547</b>		<b>633,262</b>		<b>483,183</b>		<b>545,971</b>	<b>3</b>	<b>837,859</b>	<b>4</b>	<b>2,740,820</b>	<b>13</b>
<b>SUBTOTAL STAFF</b>	<b>1</b>				<b>2</b>			<b>3</b>		<b>3</b>		
<b>FIRE SAFETY SPECIALIST (PCN 00006967)</b>					<b>149,450</b>		<b>each</b>				<b>149,450</b>	<b>1</b>

SUPPORT SERVICES

Administrative/Operational	20,401	per assigned Staff **	270,721	13.27
Volunteer Program	6,890	Per Entiry Allocation	6,890	1
Medic Program		Medic FTE/Defib Basis	50,712	6
Battalion Chief Support	76,282	27 FTE per Station	76,282	1
ECC Support		Calls/Station Basis	120,063	
Fleet Support	63,334	per Fire Suppression Equip	63,334	1
Comm/IT Support		Calls/Station Basis	166,972	
Hazmat Support			25,770	
<b>SUPPORT SERVICES SUBTOTAL</b>			<b>780,744</b>	

<b>ESTIMATED DIRECT CHARGES</b>			78,854	
<b>FIRE ENGINE USE AGREEMENT</b>		25,800 each engine	51,600	2
<b>COOPERATIVE FIRE ENGINE 20 STAFFING SHARE AGREEMENT (PCA 37129)</b>			614,896	
<b>(*Engine 20 Staffing on separate additional Exhibit "1A")</b>				

TOTAL STAFF COUNT	13
TOTAL ESTIMATED CITY BUDGET	<b>\$4,416,365</b>

SUPPORT SERVICES	13.0	Assigned Staff	
Administrative & Operational Services	0.27	Battalion Chief Support	
	**	13.27	Total Assigned Staff
		1	Fire Stations



Finance			
Training			
Data Processing			
Accounting			
Personnel			
	Procurement	3,617	Number of Calls
	Emergency Services	6	Assigned Medic FTE
	Fire Fighting Equip.	2	Monitors/Defibs
	Office Supplies/Equip.	1	Hazmat Stations
		18	Number of Hazmat Calls

Volunteer Program - Support staff, Workers Comp, and Personal Liability Insurance

Medic Program - Support staff, Training, Certification, Case Review & Reporting, Monitor/Defibrillator replacement cycle.

Battalion Chief Support - Pooled BC coverage for Cities/Agencies that do not include BC staffing as part of their contracted services.

Fleet Support - Support staff, automotive costs, vehicle/engine maintenance, fuel costs

Emergency Command Center Support - Dispatch services costs

Communications / IT Support - Support staff, communications, radio maintenance, computer support functions

Facility Support - Facility maintenance staff with associated operating costs.

Hazmat Program - Support staff, operating costs, and vehicle replacement

**FY 19/20 ESTIMATED POSITION SALARIES TOP STEP**

346,133	DEPUTY CHIEF	25,800	FIRE ENGINE
341,591	DIV CHIEF	20,401	SRVDEL
279,701	BAT CHIEF	6,890	VOL DEL
240,547	CAPT	7,785	MEDIC FTE
273,939	CAPT MEDIC	2,001	MEDIC MONITORS/DEFIBS REPLACEMENT
211,087	ENG	76,282	BATT DEL
241,591	ENG/MEDIC	18,136	ECC STATION
181,990	FF II	28,18	ECC CALLS
209,465	FF II/MEDIC	63,334	FLEET SUPPORT
143,245	FIRE SAFETY SUPERVISOR	25,222	COMM/IT STATION
149,450	FIRE SAFETY SPECIALIST	39,19	COMM/IT CALLS
129,636	FIRE SYSTEMS INSPECTOR	1,890	FACILITY STATION
75,832	OFFICE ASSISTANT III	533,86	FACILITY FTE
91,145	SECRETARY I	4,775	HAZMAT STATION
116,074	EMERGENCY SVC COORDINATOR	1,063,85	HAZMAT CALLS
235,538	COUNTY FIRE MARSHAL	1,845	HAZMAT VEHICLE REPLACEMENT
171,825	COUNTY DEPUTY FIRE MARSHAL		

**\*Cost Assumptions:**

- All Salaries based on 19/20 REVISED Salary, Pay Differential's dated February 13, 2019
- Support Services based on 19/20 Board Approved Cost Allocation
- Benefits based on FINAL Rate Matrix emailed August 2019.



COST ESTIMATE

ENGINE 20 STAFFING COSTS SHARED BETWEEN THE CITIES OF  
BANNING, **BEAUMONT**, AND THE COUNTY OF RIVERSIDE  
DATED OCTOBER 8, 2019 FOR FY2019/2020

CITY BUDGETED COST ESTIMATE

FISCAL YEAR 2019/2020

TOTAL CITY BUDGET ESTIMATE FOR FY2019/2020

\$1,844,688

\$1,844,688

COST ESTIMATE

ENGINE 20 STAFFING COSTS SHARED BETWEEN THE CITIES OF BANNING, BEAUMONT, AND THE COUNTY OF RIVERSIDE  
 DATED OCTOBER 8, 2019 FOR FY 2019/2020

*\*See notation below for estimate assumptions*

	CAPTAIN'S	CAPTAIN'S	ENGINEER'S	ENGINEER	FF II'S	FF II	TOTALS
	MEDICS	MEDICS	MEDICS	MEDICS	MEDICS	MEDICS	
<b>STA #20</b>							
Medic Engine	240,547	1	211,087	1	241,591	1	545,971
						3	418,930
						2	1,658,125
<b>SUBTOTALS</b>	<b>240,547</b>		<b>211,087</b>		<b>241,591</b>		<b>545,971</b>
						3	418,930
<b>SUBTOTAL STAFF</b>	<b>1</b>		<b>1</b>		<b>1</b>		<b>3</b>
						2	1,658,125
							<u>1,658,125</u>
							8
<b>SUPPORT SERVICES</b>							
Administrative/Operational							20,401 per assigned Staff **
Medic Program							7,785 per assigned Medics
							<u>163,208</u>
							23,355
							<u>186,563</u>
							3
							8
<b>SUPPORT SERVICES SUBTOTAL</b>							
<b>TOTAL STAFF COUNT</b>							
<b>TOTAL ESTIMATED CITY BUDGET</b>							
							<u><u>\$1,844,688</u></u>

City of Banning Share 1/3	<u>\$614,896</u>
County of Riverside Share 1/3	<u>\$614,896</u>
City of Beaumont Share 1/3	<u>\$614,896</u>

FY19/20 COST ESTIMATE  
 FOR THE E20 STAFFING  
 COST SHARING  
 2 of 3

**SUPPORT SERVICES**  
**Administrative & Operational Services**

8.00 Assigned Staff

Finance		**	8.00	Total Assigned Staff
Training				
Data Processing				
Accounting				
Personnel				
	Procurement			
	Emergency Services			
	Fire Fighting Equip.			
	Office Supplies/Equip.			

Medic Program - Support staff, Training, Certification, Case Review & Reporting  
 (PCA 37129)

**FY 18/19 POSITION SALARIES TOP STEP**

346,133	DEPUTY CHIEF	25,800	FIRE ENGINE
341,591	DIV CHIEF	20,401	SRVDEL
279,701	BAT CHIEF	6,890	VOL DEL
240,547	CAPT	7,785	MEDIC FTE
273,939	CAPT MEDIC	2,001	MEDIC MONITORS/DEFIBS REPLACEMENT
211,087	ENG	76,282	BATT DEL
241,591	ENG/MEDIC	18,136	ECC STATION
181,990	FF II	28.18	ECC CALLS
209,465	FF II/MEDIC	63,334	FLEET SUPPORT
143,245	FIRE SAFETY SUPERVISOR	25,222	COMM/IT STATION
149,450	FIRE SAFETY SPECIALIST	39.19	COMM/IT CALLS
129,636	FIRE SYSTEMS INSPECTOR	1,890	FACILITY STATION
75,832	OFFICE ASSISTANT III	533.86	FACILITY FTE
91,145	SECRETARY I	4,775	HAZMAT STATION
116,074	EMERGENCY SVC COORDINATOR	1,063.85	HAZMAT CALLS
235,538	COUNTY FIRE MARSHAL	1,845	HAZMAT VEHICLE REPLACEMENT
171,825	COUNTY DEPUTY FIRE MARSHAL		

**\*Cost Assumptions:**

- All Salaries based on 19/20 REVISED Salary, Pay Differentials dated February 13, 2019
- Support Services based on 19/20 Board Approved Cost Allocation
- Benefits based on FINAL Rate Matrix emailed August 2019.

Beaumont

SUBMITTAL TO THE BOARD OF SUPERVISORS  
COUNTY OF RIVERSIDE, STATE OF CALIFORNIA



12.

(ID # 8855)

**MEETING DATE:**

Tuesday, January 29, 2019

**FROM :** AUDITOR CONTROLLER:

**SUBJECT:** AUDITOR CONTROLLER: County/Flood Payroll Warrant/Direct Deposit General Support Services Fee, Districts: All. [\$0]

**RECOMMENDED MOTION:** That the Board of Supervisors:

1. Approves the County/Flood Payroll Warrant/Direct Deposit general support services rate of \$4.49 per warrant.

**ACTION:** Policy

  
Paul A. Angulo, County Auditor-Controller 1/15/2019

---

MINUTES OF THE BOARD OF SUPERVISORS

200

**SUBMITTAL TO THE BOARD OF SUPERVISORS COUNTY OF RIVERSIDE,  
STATE OF CALIFORNIA**

12.

**BACKGROUND:**

**Summary**

The proposed County/Flood Payroll Warrant/Direct Deposit General Support Services Fee rate increase of 10 cents to \$4.49 from previous FY 2018/19 rate of \$4.39. Attachment A provides a schedule of estimated transaction charges for FY 2019/20.

<b>FINANCIAL DATA</b>	<b>Current Fiscal Year:</b>	<b>Next Fiscal Year:</b>	<b>Total Cost:</b>	<b>Ongoing Cost</b>
COST	\$	\$	\$	\$
NET COUNTY COST	\$	\$	\$	\$
<b>SOURCE OF FUNDS:</b> Departmental Budget.			<b>Budget Adjustment:</b>	No
			<b>For Fiscal Year:</b>	2019/20

**C.E.O. RECOMMENDATION:** Approve

**BACKGROUND:**

**Summary (continued)**

The proposed rate was prepared in accordance with Board Policy B-4 and Board Policy B-28. A detailed analysis supporting the calculation is available at the Office of the Auditor-Controller.

**Impact on Residents and Businesses**

Approval of the proposed rate will allow the Auditor-Controller's Payroll Division to continue to assist its customers with the payroll function. This support will contribute to the overall efficiency of departmental operations and will allow each department to better serve Riverside County residents.

**ATTACHMENT A. County/Flood Payroll Transaction Charge FY 19/20 Projection**

  
 Stephanie P. [unclear], Principal Management Analyst      1/23/2019

201

SUBMITTAL TO THE BOARD OF SUPERVISORS  
COUNTY OF RIVERSIDE, STATE OF CALIFORNIA



IT 12.  
3.43  
(ID # 8838)

MEETING DATE:

Tuesday, January 29, 2019

FROM : HUMAN RESOURCES:

SUBJECT: HUMAN RESOURCES: Human Resources General Fund Rate Charge for Fiscal Year 2019-20, All Districts. [\$24,687,709- Departmental Budgets 100%]

RECOMMENDED MOTION: That the Board of Supervisors:

1. Approve the Assistant County Executive Officer/Human Resources Director's recommendations for Human Resources rates charged to departments for FY 2019/20, as outlined in Attachment A, and authorize the use of the methodology which sets the annual rates based on filled positions as outlined in Attachment B.

ACTION: Policy

  
Brandia Dendericks, Assistant CEO / Human Resources Director 1/17/2019

---

MINUTES OF THE BOARD OF SUPERVISORS

On motion of Supervisor Hewitt, seconded by Supervisor Perez and duly carried by unanimous vote, IT WAS ORDERED that the above matter is approved as recommended.

Ayes: Jeffries, Spiegel, Washington, Perez and Hewitt  
Nays: None  
Absent: None  
Date: January 29, 2019  
xc: HR

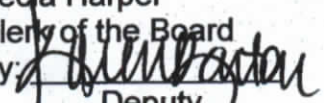
Keaja Harper  
Clerk of the Board  
By:   
Deputy

**SUBMITTAL TO THE BOARD OF SUPERVISORS COUNTY OF RIVERSIDE,  
STATE OF CALIFORNIA**

12.

**BACKGROUND:**

**Summary**

The Human Resources Department is funded primarily through direct billing of each department for services provided based on the number of filled positions and additional services requested by each department.

[REDACTED]				
<b>COST</b>	\$ 0	\$24,687,709	\$24,687,709	\$
<b>NET COUNTY COST</b>	\$ 0	\$0	\$0	\$
<b>SOURCE OF FUNDS: Departmental Budgets 100%</b>			<b>Budget Adjustment: No</b>	
			<b>For Fiscal Year: 19/20</b>	

**C.E.O. RECOMMENDATION:** Approve

The proposed FY 2019/20 Human Resources General Fund rate (rate) has increased from the FY 2018/19. In the rate development for FY 2018/19, agreements for additional staff to perform specialized services for departments were removed. However, it quickly became apparent that these services were going to continue, and HR has worked with departments to begin some of those agreements again. As such, those agreements were added back into the rates for affected departments for FY 2019/20. Those agreements equate to an 8.6% increase. Most departments' rates increased by 7.6% due to increases in legal services, rent, salaries and benefits, and other costs of doing business. These two increases combine to an average increase of 16.2%. The rate is applied to departments based on their employee count. Departments will experience changes in the total amount charged based on year-to-year changes in their staffing.

The Human Resources Department recognizes the value of a highly-qualified and talented workforce and the role our department plays in ensuring this. In FY 2019/20, the Human Resources Department will focus on efficiency, speed, attracting quality candidates, and the candidate and departmental experiences during the recruiting process. Our department will also focus on the employee relations segment of our work looking at efficiency and consistency, risk mitigation, training, and prevention. Across the department we will focus on the consolidation of services, application of LEAN methods for process improvement, metrics for decision making, marketing and communication, onboarding and orientation, and improved collaboration with our stakeholders. We will also monitor the changing health care landscape and adjust as needed.

**SUBMITTAL TO THE BOARD OF SUPERVISORS COUNTY OF RIVERSIDE,  
STATE OF CALIFORNIA**

12.

By approving these rates, the Board of Supervisors will allow the Human Resources Department to proceed with providing essential services to the County departments, including strategic planning for the future of Riverside County's workforce.



**SUBMITTAL TO THE BOARD OF SUPERVISORS COUNTY OF RIVERSIDE,  
STATE OF CALIFORNIA**

12.

**Impact on Residents and Businesses**

There is no direct impact on residents and businesses as these rates are internal to County departments.

**SUPPLEMENTAL:**

**Additional Fiscal Information**

A comparison to the prior year's rate is presented in Attachment A.

**ATTACHMENTS:**

**ATTACHMENT A. HUMAN RESOURCES RATES**

**ATTACHMENT B. METHODOLOGY FOR HUMAN RESOURCES RATE**

  
Alex Gann 1/23/2019

County of Riverside  
Human Resources Rates  
FY 2019/2020

Attachment A

12.

Fund	Dept ID	Department Name	Count 8/13/2018	2019-20 RATE	Count 9/12/2017	2016-19 RATE	RATE Change	RATE Change (%)
10000	1000100000	Board of Supervisors	56	\$ 65,361	54	\$ 57,940	\$ 7,421	11.6%
10000	1000200000	Assessment Appeals Board	3	3,502	5	5,365	(1,863)	-35.5%
10000	1100100000	Executive Office	26	30,346	25	26,824	3,522	11.9%
10000	1104400000	Grand Jury	0	-	1	1,073	(1,073)	-100.0%
10000	1105000000	Executive Office NPDES	1	1,167	0	-	1,167	100.0%
22000	1130300000	Human Resources Air Quality Division	2	2,334	2	2,146	188	7.6%
45960	1130700000	Human Resources Property Insurance	1	1,167	1	1,073	94	7.6%
46100	1130800000	Human Resources Workers' Compensation Ins	48	56,024	48	51,503	4,521	7.6%
46000	1130900000	Human Resources Medical Malpractice Ins	2	2,334	2	2,146	188	7.6%
45960	1131000000	Human Resources General Liability Insurance	25	29,179	28	30,043	(864)	-4.0%
46040	1131300000	Human Resources Safety Loss Control	17	19,842	16	17,168	2,674	14.3%
47000	1131800000	Human Resources Temporary Assignment Prog	23	26,845	31	33,262	(6,417)	-20.2%
45800	1132000000	Human Resources Exclusive Care	40	46,687	41	43,992	2,695	4.9%
46100	1132200000	Human Resources Employee Assistance Svcs	12	14,006	12	12,876	1,130	7.6%
46120	1132900000	Human Resources Occupational Health	15	17,507	17	16,240	(733)	-5.1%
46120	1133000000	Human Resources Culture of Health	3	3,502	3	3,219	283	7.6%
22050	1150100000	Community Facility Districts (CFD)	4	4,669	4	4,292	377	7.6%
10000	1200100000	Assessor	171	199,585	183	196,353	3,232	0.5%
10000	1200200000	Assessor Clerk Recorder	165	192,582	161	172,748	19,834	10.2%
45100	1200300000	Assessor Records Mgmt & Archives Program	0	-	10	10,730	(10,730)	-100.0%
33600	1200400000	Assessor CREST	10	11,672	11	11,803	(131)	-2.2%
45100	1200500000	Assessor Archives	0	-	1	1,073	(1,073)	-100.0%
10000	1300100000	Auditor Controller	55	64,194	53	56,867	7,327	11.6%
10000	1300200000	Auditor Controller Internal Audit	8	9,337	8	8,584	753	7.6%
10000	1300300000	Auditor Controller Payroll	20	23,343	17	16,240	5,103	26.6%
10000	1400100000	Treasurer Tax Collector	98	114,382	97	104,078	10,304	8.7%
10000	1500100000	County Counsel	73	85,203	75	80,473	4,730	4.7%
10000	1700100000	Registrar of Voters	32	37,349	29	31,116	6,233	18.7%
21100	1900100000	EDA Administration	40	46,687	46	49,357	(2,670)	-6.5%
21350	1900200000	EDA Community Development HUD Grants	11	12,839	11	11,803	1,036	7.6%
21550	1900300000	EDA Workforce Development	57	66,528	59	63,305	3,223	3.9%
40600	1900400000	EDA Housing Authority	104	121,385	115	123,391	(2,006)	-2.7%
21200	1900700000	EDA Library Services	4	4,669	1	1,073	3,596	330.3%
21100	1901000000	EDA Economic Development	16	18,675	16	17,168	1,507	7.6%
22100	1910700000	EDA Aviation	11	12,839	9	9,657	3,182	31.5%
22200	1920100000	EDA Fair and National Date Festival	6	7,003	7	7,511	(508)	-7.8%
10000	1930100000	EDA Edward Dean Museum	2	2,334	2	2,146	188	7.6%
10000	2000100000	Emergency Management Department	60	70,030	62	66,524	3,506	4.1%
10000	2200100000	District Attorney	663	773,831	661	730,692	43,139	4.7%
10000	2300100000	Child Support Services (DCSS)	261	304,630	262	281,118	23,512	7.2%
10000	2400100000	Public Defender	220	256,776	230	246,783	9,993	2.9%
10000	2500100000	Sheriff Administration	52	60,693	54	57,840	2,753	3.6%
10000	2500200000	Sheriff Support Services	316	366,824	316	339,058	29,766	7.6%
10000	2500300000	Sheriff Patrol	1527	1,782,262	1599	1,715,678	66,584	2.7%
10000	2500400000	Sheriff Corrections	1313	1,532,489	1366	1,465,676	66,813	3.4%
10000	2500500000	Sheriff Court Services	180	210,090	182	195,280	14,810	6.4%
10000	2500600000	Sheriff CAC Security	3	3,502	3	3,219	283	7.6%
10000	2500700000	Sheriff Ben Clark Training Center	61	71,197	57	61,159	10,038	15.1%
10000	2501000000	Sheriff Coroner	58	67,696	57	61,159	6,537	9.5%
10000	2501100000	Sheriff Public Administrator	16	18,675	15	16,095	2,580	14.7%
22250	2505100000	Sheriff CAL ID Program	29	33,848	30	32,189	1,659	4.0%
10000	2600100000	Probation Juvenile Institutions	310	361,821	357	383,050	(21,229)	-6.6%
10000	2600200000	Probation Field Services	513	598,756	533	571,893	26,863	3.5%
10000	2600700000	Probation Administration	68	79,367	69	74,035	5,332	6.0%
10000	2700200000	Fire Protection	198	231,099	208	223,178	7,921	2.4%
10000	2700400000	Fire Protection Contract Services	32	37,349	33	35,406	1,941	4.3%
10000	2800100000	Agricultural Commissioner	51	59,525	48	51,503	8,022	14.3%
51215	2900100000	LAFCO	5	5,836	3	3,219	2,617	78.3%
20200	3100200000	TLMA Administration	46	53,690	50	53,648	42	-1.0%
20200	3100300000	TLMA Consolidated Counter Services	20	23,343	20	21,459	1,884	7.6%
20250	3110100000	TLMA Building & Safety	31	36,182	31	33,262	2,920	7.6%
10000	3120100000	TLMA Planning	24	28,012	22	23,605	4,407	17.3%

County of Riverside  
Human Resources Rates  
FY 2019/2020

Attachment

12.

Fund	Dept ID	Department Name	Count		Count		RATE	RATE
			9/13/2018	2019-20 RATE	9/12/2017	2018-19 RATE	Change	Change (%)
20000	3130100000	TLMA Transportation	292	340,812	269	288,629	52,183	16.8%
20260	3130200000	TLMA Surveyor	29	33,848	29	31,116	2,732	7.6%
20008	3130700000	TLMA Transportation Equipment Garage ISF	21	24,510	23	24,678	(168)	-1.8%
22650	3130800000	TLMA ALUC	3	3,502	3	3,219	283	7.6%
10000	3140100000	TLMA Code Enforcement	34	39,684	37	39,700	(16)	-1.2%
10000	4100100000	RUHS Behavioral Health Public Guardian	37	43,185	34	36,481	6,704	17.1%
10000	4100200000	RUHS Behavioral Health Treatment	1173	1,369,085	1158	1,242,498	126,587	9.0%
10000	4100300000	RUHS Behavioral Health Detention	130	151,732	132	141,632	10,100	5.9%
10000	4100400000	RUHS Behavioral Health Administration	255	746,742	255	323,607	423,135	128.6%
10000	4100500000	RUHS Behavioral Health Substance Abuse	178	207,756	187	200,645	7,111	2.4%
10000	4200100000	RUHS Public Health	463	941,712	448	480,690	461,022	93.7%
10000	4200200000	RUHS California Children's Services	135	157,567	139	149,143	8,424	4.5%
10000	4200400000	Environmental Health	177	206,588	181	194,207	12,381	5.2%
10000	4200600000	Animal Services	196	228,764	206	221,032	7,732	2.3%
40050	4300100000	RUHS Regional Medical Center	2718	4,519,291	2652	3,016,512	1,502,779	48.0%
10000	4300200000	RUHS Medical Indigent Service Program	32	37,349	32	34,335	3,014	7.6%
10000	4300300000	RUHS Detention Health Services	245	285,956	238	255,367	30,589	10.7%
40090	4300600000	RUHS Community Health Clinics	378	441,189	325	348,715	92,474	100.0%
40200	4500100000	Waste Management	182	212,424	179	192,061	20,363	9.4%
10000	5100100000	Dept of Public Social Services	3758	4,534,668	3911	4,343,575	191,093	3.2%
21050	5200100000	Community Action Agency	18	21,009	18	19,313	1,696	7.6%
21050	5200200000	Community Action Agency Energy Program	30	35,015	34	36,481	(1,466)	-5.1%
21050	5200300000	Community Action Agency Other Programs	1	1,167	1	1,073	94	7.6%
21450	5300100000	Office on Aging Title III	53	61,860	56	60,086	1,774	1.8%
10000	5400100000	Veteran Services	15	17,507	17	18,240	(733)	-5.1%
10000	6300100000	Cooperative Extension	5	5,836	4	4,292	1,544	34.5%
10000	7200100000	Facilities Management	41	47,854	39	41,846	6,008	13.1%
47200	7200200000	Facilities Management Custodial Services	154	179,744	168	180,259	(515)	-1.4%
47210	7200300000	Facilities Management Maintenance	160	186,747	151	162,018	24,729	14.0%
47220	7200400000	Facilities Management Real Estate	25	29,179	26	27,897	1,282	3.4%
10000	7200500000	Facilities Management Project Mgt Office	25	29,179	27	28,970	209	-0.4%
10000	7200600000	Facilities Management Energy	1	1,167	2	2,146	(979)	-46.2%
10000	7200700000	Facilities Management Parking	20	23,343	15	16,095	7,248	43.4%
10000	7300100000	Purchasing	29	33,848	24	25,751	8,097	30.0%
45700	7300400000	Purchasing Supply Services	4	4,669	4	4,292	377	7.6%
45300	7300500000	Purchasing Fleet Services	49	57,191	53	56,867	324	-0.5%
45620	7300600000	Purchasing Central Mail Services	8	9,337	10	10,730	(1,393)	-13.9%
45500	7400100000	Riverside County Information Technology	342	399,171	334	358,372	40,799	10.1%
45520	7400600000	RCIT Communication Solutions	31	36,182	30	32,189	3,993	11.2%
22570	7400900000	RCIT Geographical Information System	6	7,003	7	7,511	(508)	-7.8%
24625	915201	EDA CSA 152 NPDES	19	22,176	21	22,532	(356)	-2.7%
23010	915202	EDA CSA Administration Operating	9	10,504	9	9,657	847	7.6%
40200	943001	WRMD Operating	17	19,842	19	20,386	(544)	-3.8%
25540	931250	Parks	106	123,720	102	109,443	14,277	11.8%
51335	935001	Riverside County Habitat Conservation Agency (RCHCA)	3	3,502	3	3,219	283	7.6%
25800	938001	Children & Families First Commission	33	38,516	40	42,919	(4,403)	-11.3%
51000	946001	Saltion Sea Authority Payroll	3	3,502	1	1,073	2,429	222.7%
15100	947200	Flood Control District	216	252,108	234	251,075	1,033	-0.7%
22800	985101	Public Authority Administration	3	3,502	3	3,219	283	7.6%
22800	985110	PA Registry	8	9,337	77	13,949	(4,612)	-33.8%
22800	985120	IHSS Public Authority Operations	54	63,027	0	68,670	(5,643)	-9.2%
		<b>Total</b>		<b>\$ 24,687,709</b>		<b>\$ 21,243,877</b>	<b>\$ 3,443,832</b>	<b>16.2%</b>
		<b>Total employee count</b>	<b>19142</b>		<b>19456</b>			



County of Riverside  
Human Resources Rates FY 19-20  
ATTACHMENT B

## METHODOLOGY FOR HUMAN RESOURCES RATE

1. The Human Resources positions to be funded for the year are identified, budgeted at estimated step (assuming 5.5% step increases) with a 46.3% factor for benefit costs. Salaries are based on 2096 hours of pay.
2. The HR infrastructure positions are categorized by services provided and to whom:

### INFRASTRUCTURE:

- Employee Services (Records)
- Operations
- Accounting
- Classification/Compensation
- Talent Acquisition Center of Expertise
- Talent Management Center of Expertise\*
- Benefits\*
- Administration

\* While part of the infrastructure of the department, the majority of benefits is funded by fees and a portion of Talent Management Center of Expertise is funded by NCC.

3. The HR departmental services teams are combined into two teams – Business Partners and services teams.
4. The total cost for services and supply budget is calculated, then reduced by offsetting revenue.
5. One rate per position is calculated by dividing total cost (not reimbursed from other sources)/total filled positions at the time of rate development. Departments are charged based on filled positions.
6. A report of filled positions for each DeptID is taken semiannually in November and May. If a department's number of filled positions increases by five or more, their charges for the remainder of the current fiscal year are adjusted upward, based on an equivalent per employee charge. Reductions in staffing will be treated the same as increases.



## Staff Report

**TO:** Mayor, and City Council Members  
**FROM:** Jeffrey Mohlenkamp, Finance Director  
**DATE:** January 7, 2020  
**SUBJECT:** Approval of Payment for Fire Protection Services

---

### Background and Analysis:

The City contracts with the County of Riverside (County) for fire protection services. These services are delivered by the California Department of Forestry and Fire Protection (Cal Fire). The County has submitted the billing for the costs of service for the first quarter of FY 2019-20 covering the period of July 1, 2019, through September 30, 2019, in the amount of \$952,444.77.

Staff has reviewed the invoice and supporting detail of the billing, Attachment 1. The costs are in compliance with our contract and are within the budgeted amount. The budget for fire protection service for the fiscal year is \$4,390,200.

### Fiscal Impact:

The cost of fire protection services is fully budgeted for FY 2019-20. This first quarter billing is within the budgeted amount and is for services already rendered by the County and Cal Fire. There is no fiscal impact from this item.

### Recommended Action:

Approval of payment of first quarter fire protection services to the County in the amount of \$952,444.77.

### Attachments:

- A. Fire Services Invoice - FY 2019-20 1st Qtr

**Item Attachment Documents:****13. City Council Approval of Change Order No. 12 for the Wastewater Treatment Plant Upgrade/Expansion in the Amount Not to Exceed \$91,417.26**

## Recommended Action:

Approval of Change Order No. 12 for the Wastewater Treatment Plant Upgrade/Expansion in the amount not to exceed \$91,417.26.



## Staff Report

**TO:** Mayor, and City Council Members  
**FROM:** Kristine Day, Assistant City Manager  
**DATE:** January 7, 2020  
**SUBJECT:** City Council Approval of Change Order No. 12 for the Wastewater Treatment Plant Upgrade/Expansion in the Amount Not to Exceed \$91,417.26

---

### Background and Analysis:

#### Wastewater Treatment Plant Change Order No. 12:

##### Item #1 - RO-Sulfuric Acid Chemical Piping Material Change:

The sulfuric acid piping at the Tank Farm #1 was designed and specified to be PVDF pipe anticipating a certain level of chemical concentration. After further discussions with staff, it was determined for operational peak performance and cost savings a higher chemical concentration would be better suited. Alloy 20 piping was evaluated as an alternative to PVDF piping which provides a higher degree of service reliability for the chemical concentration to be used. As a result, staff recommended making this change. Due to potential delay costs of \$3,000 per day, staff presented this change order item to the Mayor for approval on December 17, 2017.

The cost for this work is \$1,514.16.

##### Item #2 - Solids Feed Pump TE/TSH Thermocouple Elements:

Thermocouple temperature elements are safety features on the motors in the event a motor runs dry. The electrical plans called out for these devices but the pump plan did not. As a result, staff recommends adding these in order to protect the motors.

The cost for this work is \$2,354.10.

**Item #3 - Solids Handling Bldg. Changes:**

The chemical storage equipment in the solids handling building is proposed to be modified from smaller storage totes to bulk tanks. This was part of the owner initiated change order which was presented to the City Council on May 7, 2019. The original bid called for three chemical tote stands which would each hold a 250 gallon tote. The new design is for a single bulk storage tank (6,500 gallon capacity) with an original estimate on May 7, 2019 of \$75,000. During the design process, a pump system was added as well as modifications to the floor drain system and one of the radiant heaters. This change will significantly reduce operator time spent changing out chemical totes and will reduce the cost of chemicals due to buying in bulk. Additionally, this change will improve operator safety due to not having to change out totes using a forklift and minimizing spillage of polymer.

The cost for this work is \$87,549.00.

**Summary of Change Order No. 12 Costs:**

The cumulative costs associated with this change order is in the amount not to exceed \$91,417.26 and will not impact the project schedule. The costs for the change order are as summarized below:

Item	Cost
Item #1 - RO-Sulfuric Acid Chemical Piping Material Change	\$1,514.16
Item #2 - Solids Feed Pump TE/TSH Thermocouple Elements	\$2,354.10
Item #3 - Solids Handling Bldg. Changes	\$87,549.00
<b>Total:</b>	<b>\$91,417.26</b>

**Wastewater Treatment Plant Change Order Summary:**

CO No.	Description	Reason for Change	Amount
1	MBR System Improvements	Enhance the performance of MBR System	\$149,741.00
2	RO System Electrical Modifications & Storm Drain System Material Change	Design & Material Updates	(\$245.00)
3	New Aeration Basin 1 through 3 Excavation	Conflict with Existing Utilities	\$19,998.00
4	Structural and Mechanical Modifications	Pre-Selected Submittals	\$57,450.64



5	Vactor Truck Dump Station Modifications	Conflict with Construction	NTE \$15,000.00
6	EDI/Fine Coarse Bubble Diffuser Equipment	Design Change	\$24,298.00
7	Various Changes – MBR/RO Structural, Site Civil & Headworks SCADA Design Modifications	Design Changes	\$59,167.49
8	Various Changes - Demolition, Piping Realignment, Material Change, and Electric Actuated Valve Voltage Change	Unforeseen Conditions and Value Engineering	\$7,942.00
9	Various Changes - Solids Handling Bldg. Conveyor Capacity Increase, Electrical Yard Vaults Cover Changes, Additional Pothole Investigation and Existing Duct Bank Removal, and Yard Utilities	Design Changes, Conflict with Construction, Owner Requested Changes	\$138,531.73
10	MBR Chemical Area Changes & Other Misc. Changes and Inclement Weather Impact Nov-18 to May-19	Owner Requested Changes & Inclement Weather	\$596,031.05
11	Frontier Internet Provider Duct Bank Modifications, 30-inch MBR & 20-inch Plant Effluent Pipeline Elevation and Alignment Modifications, Additional Safety Required Handrail at Retaining Wall and Generator	Design Changes, & Conflict with Construction	\$81,128.29
12	RO-Sulfuric Acid Chemical Piping Material Change, Solids Feed Pump TE/TSH Thermocouple Elements, Solids Handling Bldg. Changes	Design Changes, Owner Requested Changes	\$91,417.26

<b>WWTP Contingency</b>	<b>Budget Amount</b>	<b>Change Orders 1-12</b>	<b>Remaining</b>
	<b>\$4,000,000.00</b>	<b>\$1,240,460.46</b>	<b>\$2,759,539.54</b>

**Fiscal Impact:**

Wastewater Treatment Plant Expansion/Renovation:

The project accounting below represents the status of funds should the change order be approved by City Council. A contingency balance of \$2,759,539.54 would remain should City Council approve this item.

<b>WWTP</b>	<b>Budget Amount</b>	<b>Paid to Date</b>	<b>Remaining</b>
Design	\$2,709,798.23	\$2,556,828.66	\$152,969.57
Construction Management	\$5,308,585.72	\$2,620,177.77	\$2,688,407.95
Equipment	\$252,906.00	\$253,293.50	(\$387.50)
Permits	\$324,776.76	\$79,058.64	\$245,718.12
Construction	\$53,910,737.00	\$26,788,463.64	\$27,122,273.36
Contingency	\$4,000,000.00	\$418,810.11	\$3,581,189.89
<b>Total</b>	<b>\$66,506,803.71</b>	<b>\$32,716,632.32</b>	<b>\$33,790,171.39</b>

**Recommended Action:**

Approval of Change Order No. 12 for the Wastewater Treatment Plant Upgrade/Expansion in the amount not to exceed \$91,417.26.

**Attachments:**

- A. Change Order No. 12 - Lyles



# City of Beaumont Wastewater Treatment Plant Salt Mitigation Upgrade Project Change Order No. 12

Dec 16, 2019

		Amount	Calendar Days	Comp. Date
<b>Contractor:</b>	W.M. Lyles Co.	<b>Original Contract:</b>	\$ 53,312,000.00	820 1/26/2021
<b>Project Name:</b>	Wastewater Treatment Plant Salt Mitigation Upgrade Project	<b>Previous Approved Changes:</b>	\$1,132,168.20	95 5/1/2021
<b>Contract No.:</b>	C18-80	<b>This Change: Amount</b>	\$91,417.26	0
<b>CO Number:</b>	12	<b>Revised Contract:</b>	\$54,535,585.46	915 5/1/2021
		<b>Previous Phase 1 Completion Date</b>		4/26/2020
		<b>Revised Phase 1 Completion Date</b>		4/26/2020

This change order covers changes to the subject contract as described herein. The Contractor shall supply all labor, equipment and materials to complete the Change Order items for the lump sum price agreed upon herein. All Change Order items must be submitted to the City for approval prior to fabrication.

Item No.	PCO No.	Description of Changes	Amount	Phase 1 Time Extension (CD*)	Phase 2 / Project Completion Time Extension (CD*)
1	25	DCM-17, CLAR-23, WML COP-026R1 RO-Sulfuric Acid Chemical Piping Material Change	\$1,514.16	0	0
2	29	RFI #094, WML COP-029 Solids Feed Pump TE/TSH Thermocouple Elements	\$2,354.10	0	0
3	30	DCM #16, CLAR-20, WML COP-030 Solids Handling Bldg. Changes	\$87,549.00	0	0
4			\$0.00	0	0
<b>NET CHANGE IN CONTRACT AMOUNT – INCREASE (OR-DECREASE)</b>			<b>\$91,417.26</b>	<b>0</b>	<b>0</b>

\*Calendar Days

The amount of the Contract will be increased/decreased by the amount of Ninety-One Thousand Four Hundred Seventeen Dollars and twenty-six cents (\$91,417.26). The Contract Time will be increased by zero (0) calendar days.

The Contractor agrees to furnish all labor, equipment and materials and to perform all other necessary work, inclusive of the directly or indirectly related work, within the approved time extension required to complete the above Change Order items. The undersigned Contractor approves the foregoing Change Order as to the changes, if any, in the Contract Price specified for each item including any and all supervision costs and other miscellaneous costs relating to the change in Work, and as to the extension of time allowed, if any, for the completion of the entire Work on account of said Change Order. The City and the Contractor hereby agree that this Change Order constitutes full mutual accord and satisfaction for all time, all costs, and all impacts related directly or indirectly to this Change Order. The Contractor hereby agrees that this Change Order represents the full equitable adjustment owed under the Contract, and further agrees on behalf of himself and all subcontractors to waive all right to file any further claims or request for equitable adjustment arising out of or as a result of this Change Order or the cumulative effect of this Change Order on the performance of the overall Work under the Contract. This document will become a supplement of the contract and all provisions will apply hereto. It is understood that the Change Order shall be effective when approved by the City.

**Recommended:** Charles J. Janda, Date: 12-16-2019  
MWH Constructors, Senior Resident Engineer

**Accepted:** [Signature], Date: 12-16-19  
W.M. Lyles Co. Contractor

**Approved:** \_\_\_\_\_, Date: \_\_\_\_\_  
Albert A. Webb Associates, Program Manager

**Approved:** \_\_\_\_\_, Date: \_\_\_\_\_  
City of Beaumont, City Manager

**Water Treatment Plant Salt Mitigation Upgrade Project**  
**Technical Justification:**

PCO-25	
Design Adjustment: CLAR-23 / DCM-17 WML COP-026R1	RO Chemical - Sulfuric Acid Piping Material Change

City of Beaumont (Owner) has directed the Engineer to evaluate a potential alternative for currently specified PVDF piping for sulfuric acid service (93 to 96% concentration). As noted in Clarification #12, the sulfuric acid piping at the Tank Farm #1 was specified to be PVDF pipe and inside the MBR building 2" X 1/2" PVDF Proline piping (double containment). Alloy 20 piping was evaluated as an alternative that would potentially offer cost savings compared to PVDF piping and also provide a higher degree of service reliability (PVDF does not perform well if the sulfuric acid is above the design concentration of 96%).

Following the evaluation, it was determined that Alloy 20 piping may be used in lieu of currently specified PVDF piping. In addition, following shall apply:

Design and Scope Changes:

- Alloy 20 piping shall be Sch 40 piping with ID matching the current design.
- Alloy 20 piping shall be butt welded except at locations where it connects to valves and appurtenances. At these locations, connections shall be flanged. All gasket materials shall be compatible for sulfuric acid service (90% to 100% concentration).
- Based on the input from Owner, exposed Sulfuric Acid piping in the MBR building and Tank Farm shall not have double containment and shall be single wall, sch 40, 1/2" ID, Alloy 20 pipe. As noted in Clarification 12.1, buried Sulfuric Acid service piping shall be double contained piping consisting of SCH 80 CPVC containment pipe and 1/2" (ID) Tygon 2375-C tubing.
- Valves and appurtenances (strainers and injection quill) currently shown in the plans shall remain with following changes:
  - o Provide a cost for Alloy 20 valves and appurtenances with flanged connections.
  - o In order to potentially avoid additional costs and long lead times PVDF valves and strainers as currently specified may be acceptable (with flanged connections). Please provide a cost for this alternate option.
- Post field fabrication, piping system shall receive pickle and passivation protection both internal and external.
- Sulfuric Acid chemical pump skid piping shall be changed from CPVC material to PVDF.

Cost Impact:

The contractor's initial quote offered a cost credit of -\$19,969.00 excluding pickling & passivation. Design Engineer review comments required pickling & passivation for both internal and external of piping system, which required additional fittings, labor cost and outside vendor. MWHC evaluated the extra cost proposal by the Contractor.

MWHC recommends a contract cost increase of \$1,514.16 to be executed in a change order for changes to the complete sulfuric acid chemical dosing system; MBR\RO Building deliver piping, Pumping Skid and Sulfuric Acid Storage Tank Piping.

## CITY OF BEAUMONT WWTP SALT MITIGATION UPGRADE PROJECT

**CHANGE ORDER PROPOSAL (COP) # 026R1  
(By Contractor)**

<b>To (Engineer/CM):</b> MWH Constructors Attention: Charles Reynolds Phone: 702-497-8024 Email: Charles.w.reynolds@mwhconstructors.com	<b>From (Contractor):</b> W.M. Lyles Co. Attention: Juan C. Ahumada Phone: 951-972-2056 Email: jahumada@wmlylesco.com
<b>PCO/DCM No.:</b> DCM no.17	
<b>Subject:</b> RO Chemical – Sulfuric Acid Piping Material Change	
<b>Reference Documents:</b> Clarification no. 17	
<b>DESCRIPTION</b>	
<p>Please review the attached change order proposal associated with the piping changes indicated in clarification no. 17. Below is a summary of these changes.</p> <p>Changing of the above grade sulfuric acid piping material from double contained PVDF to butt-welded alloy 20.</p> <p>In our proposal we are including flanged PVDF diaphragm valves in lieu of ball valves on the sulfuric acid piping. Cut sheets for the diaphragm valves check valve and strainers which we have taken into consideration in our pricing is included in this proposal.</p> <p>Also, included in this proposal is the additional costs associated from H2O Innovations for changing the piping on the sulfuric acid skid to PVDF as indicated in the email from Boris Petkovic dated 11/08/19.</p> <p>This proposal is valid for 30 days.</p>	
<b>COST ESTIMATE</b>	
Total additional cost of \$1,514.16, see attached breakdown.	
<b>SCHEDULE IMPACT</b>	
None	

<b>Received by MWH Constructors (Date):</b>	
<b>RESPONSE</b>	
<b>Response By:</b>	<b>Date:</b>

Final Distribution: Juan C. Ahumada, W.M. Lyles Co.  
Brian Knoll, Webb Associates  
MWH Inspector

W. M. Lyles Co.  
 42142 Roick Drive  
 Temecula, CA 92590

Date: 2-Oct-19

Reference #: Clarification No. 17 r1

Attention: Charles W. Reynolds

JOB LOCATION: City of Beaumont WWTP Slat Mitigation Upgrade Project

DESCRIPTION: RO Chemical - Sulfuric Acid Piping Material Change

Item:		Unit	Total MH	Total MH Cost	Eq. Cost	Material	Subcont.	Total Cost
1	Pipe Installation	LS	-16	\$ (1,234.40)	\$ (515.52)	\$ (11,281.23)	\$ 15,700.00	\$ 2,668.84
		LS	0	\$ -	\$ -	\$ -	\$ -	\$ -
Total Costs			-16	\$ (1,234.40)	\$ (515.52)	\$ (11,281.23)	\$ 15,700.00	\$ 2,668.84

Subtotal		\$	2,668.84
Mark-up - Labor	15%	\$	(185.16)
Mark-up - Equipment	15%	\$	(77.33)
Mark-up - Materials	15%	\$	(1,692.19)
Mark-up - Subcontractor	5%	\$	785.00
Bond	1.0%	\$	14.99
<b>Total This Change Order</b>		<b>\$</b>	<b>1,514.16</b>

Comments:





Location	Size	Description	Qty	Unit	Unit Price	Total
Tank Fill	2"	Flanged Female Camlock fitting (316SS)	2	EA	\$ 305.21	\$ 610.42
Tank Fill	2"	Alloy 20 Weld Neck Flange	8	EA	\$ 210.06	\$ 1,680.45
Tank Fill	2"	Alloy 20 Butt Weld 90°	3	EA	\$ 106.39	\$ 319.18
Tank Fill	2"	Alloy 20 Pipe	16	LF	\$ 60.70	\$ 971.17
Tank OF	2"	Alloy 20 Weld Neck Flange	1	EA	\$ 86.14	\$ 86.14
Tank OF	2"	Alloy 20 Butt Weld 90°	1	EA	\$ 106.39	\$ 106.39
Tank OF	2"	Alloy 20 Pipe	8	LF	\$ 60.70	\$ 485.58
Tank Outlet	2"	Alloy 20 Weld Neck Flange	4	EA	\$ 210.06	\$ 840.22
Tank Outlet	2"	Alloy 20 Butt Weld 90°	1	EA	\$ 106.39	\$ 106.39
Tank Outlet	2"	Alloy 20 Butt Weld 45°	1	EA	\$ 86.14	\$ 86.14
Tank Outlet	2"	Alloy 20 Butt Weld Tee	1	EA	\$ 214.15	\$ 214.15
Tank Outlet	2"x1/2"	Alloy 20 Butt Reducer	1	EA	\$ 115.94	\$ 115.94
Tank Outlet	2 1/2"	316SS Blind Flange w/1" hole	1	EA	\$ 88.66	\$ 88.66
Tank Outlet	1/2"	Alloy 20 Plain End x Threaded Nipple	1	EA	\$ 47.74	\$ 47.74
Tank Outlet	1/2"	Alloy 20 Threaded Coupling	1	EA	\$ 41.46	\$ 41.46
Tank Outlet	1/2"	PVDF Male NPT x Tube Adapter	1	EA	\$ 4.77	\$ 4.77
Tank Outlet	2 1/2"	CPVC Vanstone Flange	1	EA	\$ 17.88	\$ 17.88
Skid Feed	2"	CPVC Vanstone Flange	1	EA	\$ 8.63	\$ 8.63
Skid Feed	2"	316SS Blind Flange w/1" hole	1	EA	\$ 75.02	\$ 75.02
Skid Feed	1/2"	Alloy 20 Plain End x Threaded Nipple	1	EA	\$ 47.74	\$ 47.74
Skid Feed	1/2"	Alloy 20 Threaded Coupling	1	EA	\$ 41.46	\$ 41.46
Skid Feed	1/2"	PVDF Male NPT x Tube Adapter	1	EA	\$ 4.77	\$ 4.77
Skid Feed	1/2"	Alloy 20 Weld Neck Flange	1	EA	\$ 54.56	\$ 54.56
Skid Feed	1/2"	Alloy 20 Butt Weld 90°	4	EA	\$ 46.04	\$ 184.14
Skid Feed	1/2"	Alloy 20 Pipe	5	LF	\$ 18.68	\$ 93.42
Skid Discharge	1/2"	Alloy 20 Weld Neck Flange	4	EA	\$ 54.56	\$ 218.24
Skid Discharge	1/2"	Alloy 20 Pipe	140	LF	\$ 18.68	\$ 2,615.69
Skid Discharge	1/2"	Alloy 20 Butt Weld 90°	23	EA	\$ 46.04	\$ 1,058.81
Skid Discharge	1/2"	Alloy 20 Butt Weld Tee	1	EA	\$ 119.62	\$ 119.62
Additional	1/2"	Alloy 20 Weld Neck Flange	16	EA	\$ 54.56	\$ 872.96
Additional	1/2"	316SS BNG w/Viton Gaskets	16	EA	\$ 12.25	\$ 196.00
Misc	2 1/2"	316SS BNG w/Viton Gaskets	1	EA	\$ 28.60	\$ 28.60
Misc	2"	316SS BNG w/Viton Gaskets	5	EA	\$ 24.50	\$ 122.50
Misc	1/2"	316SS BNG w/Viton Gaskets	14	EA	\$ 12.25	\$ 171.50
Valves	1/2"	Flanged PVDF Diaphragm Valve	2	EA	\$ 233.51	\$ 467.02
Valves	2"	Flanged PVDF Diaphragm Valve	3	EA	\$ 725.58	\$ 2,176.75
Valves	2"	Flanged PVDF Check Valve	1	EA	\$1,047.01	\$ 1,047.01
Valves	2"	PVDF Strainer	2	EA	\$2,101.52	\$ 4,203.04
Consumable		Welding Rod	1	LS	\$ 300.00	\$ 300.00
Consumable		Welding Gas	1	LS	\$ 200.00	\$ 200.00
Total						\$20,130.16





1048 La Mirada Court  
 Vista, CA 92081  
 (760) 598-2206

DATE: 8-Nov-19

Quote No : CO-007rev1

**Quote**

**Client :** Administrator, City of Beaumont  
 Client PO# : \_\_\_\_\_  
 Contact : Amer Jakher  
 Project MR# : \_\_\_\_\_  
 City : Beaumont, CA  
 Country : USA  
 Telephone : 951 769 8520

**Project Information:**  
 Project Name: City of Beaumont RO System  
 Project Number: U18865  
 Location: Beaumont, CA  
 Client : City of Beaumont  
 Contact : [borisp@aguaeng.com](mailto:borisp@aguaeng.com)

Quantity	Unit	Description	Unit price	Amount
		Chemical Dosing Skids, each with 2 on-line redundant dosing pumps, piping, valves, instruments, frame, PLC and HMI programming - One (1) ammonia sulfate skid and one (1) sulfuric acid skid (parts and labor).	\$ 37,926.00	\$ 37,926.00
<p>The total in this updated change order reflects an additional \$9,146 to the original change order amount (\$28,780) to change the valves, fittings, piping and materials on the sulfuric skid to PVDF/PFA/Viton for suitability for 93%-98% sulfuric acid.</p>				
<p>At this time, H2O does not feel that this change will cause a delay in the construction of the project and are therefore, not requesting an extension to the Contract Time. However, H2O reserves the right to review the impact of this change along with all other changes on the Contract Time at a future date.</p>				

Total without tax	\$ 37,926.00
Admin fee	\$ -
<b>TOTAL</b>	<b>\$ 37,926.00</b>

\*Please note that taxes are not included and will be added as applicable

**Payment**  
 - As per existing contract  
 \_\_\_\_\_  
 \_\_\_\_\_  
 \_\_\_\_\_

**Prepared by**  
 \_\_\_\_\_  
 Dan Dragland  
 \_\_\_\_\_  
 11/8/2019  
 Date Signature

**Authorized by**  
 \_\_\_\_\_  
 \_\_\_\_\_  
 Date Signature

**Notes**  
 \_\_\_\_\_  
 \_\_\_\_\_  
 \_\_\_\_\_



**QUOTATION**

13.

**Billing Inquiries:** (951) 340-4444

**Sell To:**  
 W M Lyles Company J  
 P O Box 4377  
 Attn: Karen Higham  
 Fresno, CA 93744

**Ship To:**  
 W M Lyles Company J  
 14903 River Road  
 Corona, CA 92880

**Page:** 1 of 2  
**Bid Number:** 6680282  
**Quote Date:** 10/15/2019  
**Entered By:** Francisco Alvarado  
**Description:** FA1-CHANGE ORDER-MICHEAL BOSNER

**Account Number:** 079562  
**Contact Name:**  
**Contact Phone:** (951) 973-7393

Note: The following does not include Shipping & Handling, Tax, or other applicable charges.

Product #	Description/Notes	Uom	Qty	Price	Total
/ML302585426	2" ALLOY 20 WELD NECK FLANGE 150# STD TEXAS	EA	13	210.0560	2,730.73
/ML302585427	2" ALLOY 20 BW 90 TEXAS	EA	5	106.3920	531.96
/ML302585429	2" SMLS S40 ALLOY 20 PIPE TEXAS	FT	40	60.6980	2,427.92
/ML302585430	2" ALLOY 20 BW 45 TEXAS	EA	1	86.1355	86.14
/ML302585687	2" ALLOW 20 BW TEE TEXAS	EA	1	214.1480	214.15
/ML302585697	2" X 1/2" ALLOY 20 BW REDUCER TEXAS	EA	1	115.9400	115.94
/ML302585700	2-1/2" 316SS BLIND FLANGE WITH 1" IPS HOLE IN THE CENTER	EA	1	88.6600	88.66
/ML302585701	1/2"X6" ALLOY 20 NIPPLE TOE SCH 40	EA	2	47.7400	95.48
/ML302585703	1/2" 3M ALLOY 20 THR COUPLING TX	EA	2	41.4645	82.93
/ML302585716	2" 316SS BLIND FLANGE W/ 1" IPS HOLE IN THE CENTER	EA	1	75.0200	75.02
/ML302585719	1/2" ALLOY 20 WELDNECK FLANGE 150LB STD TEXAS	EA	5	54.5600	272.80
/ML302585725	1/2" ALLOY 20 BW 90 TEXAS	EA	27	46.0350	1,242.95
/ML302585736	1/2" ALLOY 20 PIPE CUT AT 5'	FT	5	18.6835	93.42
/ML302585737	1/2" ALLOY 20 PIPE SRL	FT	140	18.6835	2,615.69
/ML302585738	1/2" ALLOY 20 BW TEE TX	EA	1	119.6195	119.62
	PVDF DIAPHRAGM VALVES				
070.158584	1/2 PVDF/PPG FLG DIA VLV TEF	EA	1	233.5120	233.51
070.158589	2 PVDF/PPG FLG DIA VLV TEF	EA	1	725.5840	725.58
5117.020	PVDF/VIT B CK VLV 2" FLG ASAHI SUGGESTED GASKETS	EA	1	1,047.0064	1,047.01
3862.005	TEF AV GSK 1/2"	EA	1	17.0632	17.06
3862.020	TEF AV GSK 2"	EA	1	26.5408	26.54
	Y STRAINER				
5329.620	PVDF LINE STRAINER 2" FLG	EA	1	2,101.5200	2,101.52

QUOTATION

13.



Billing Inquiries: (951) 340-4444

Sell To:  
 W M Lyles Company J  
 P O Box 4377  
 Attn: Karen Higham  
 Fresno, CA 93744

Page: 2 of 2  
 Bid Number: 6680282  
 Quote Date: 10/15/2019  
 Entered By: Francisco Alvarado  
 Description: FA1-CHANGE ORDER-MICHEAL BOSNER

Account Number: 079562  
 Contact Name:  
 Contact Phone: (951) 973-7393

Ship To:  
 W M Lyles Company J  
 14903 River Road  
 Corona, CA 92880

Note: The following does not include Shipping & Handling, Tax, or other applicable charges.

Product #	Description/Notes	Uom	Qty	Price	Total
200.243303	2"S/STEEL T316 MALE KAMLOK X FLANGE	EA	1	212.8550	212.86
1300D520	Q-D GSKT 2" VIT	EA	1	10.4020	10.40
0703.197	PVDF HOSE ADPT 1/2"MT X 3/4"H	EA	2	3.4485	6.90
0930.027	O-CLIP 1" 304SS	EA	2	1.3230	2.65
3655G020	CPVC VAN STONE FLG N80 2" SLOANE	EA	1	8.6292	8.63
3655G025	CPVC VAN STONE FLG N80 2.5" SLOA	EA	1	17.8767	17.88
	---- Package Subtotal: 15,203.95				

Subtotal: 15,203.95

225

SOLD TO:  
 WM LYLES COMPANY  
 PO BOX 4377  
 FRESNO, CA. 93744-4377



JOB ADDRESS:  
 WP-WESTERN PACIFIC  
 13326 ELLIOT AVE  
 CHINO CA 91710

# Quote

Date  
 10/16/2019

www.WestPacProducts.com  
 Bolts-Gaskets-Strut/Fittings-PipeSupports

Quote #	Beaumont	Rep	SP	FOB	Chino Ca.
Description	Qty	U/M	Cost	Total	
1/2" 150# FF 1/8" VITON GASKETS	5	ea	5.00	25.00T	
2-1/2" 150# FF 1/8" VITON GASKETS	1	ea	18.00	18.00T	
2" 150# FF 1/8" VITON GASKETS	14	ea	14.00	196.00T	
1/2" 150# BOLT SET 316 STAINLESS STEEL	5	ea	7.25	36.25T	
2" 150# BOLT SET 316 STAINLESS STEEL	14	ea	10.50	147.00T	
2 1/2" 150# BOLT SET 316 STAINLESS STEEL	1	ea	10.60	10.60T	
SanBerdo-new7.75			7.75%	33.55	
			<b>Total</b>	\$466.40	

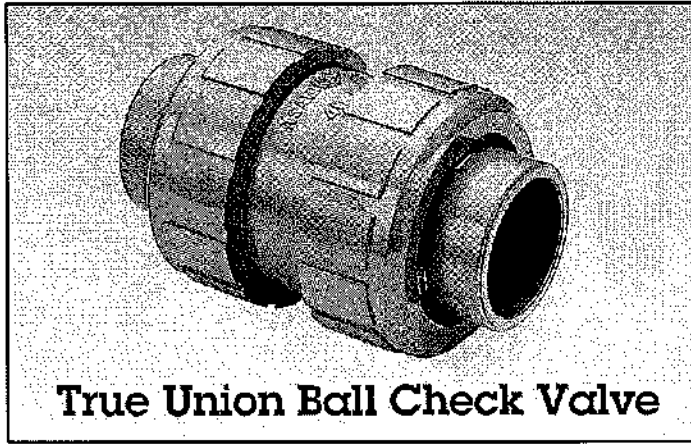

**True Union Ball Check Valve**

**Specifications**

**Sizes:** True Union: 1/2" - 2"  
Single Union: 3" - 4"

**Models:** Socket, Threaded, Flanged (ANSI), Butt End

**Bodies:** PVC, CPVC, PP and PVDF

**Seats:** EPDM, FKM, PTFE

**Seals:** EPDM, FKM, PTFE

**Option:** Foot Valve

**Sizes 1/2" - 4" PVC/EPDM/FKM Models  
NSF-61 Certified**

**Standard Features (Sizes 1/2" - 2")**

- Uniseat/seal of EPDM or FKM
- Ball is the only moving part. It unseats to permit flow in one direction but seals against seat to prevent back flow
- May be used vertically or horizontally
- Minimum shut-off of 5psi
- All sizes rated for full vacuum service
- Solid thermoplastic ball

**Options:**

- PTFE coated FKM uniseat/seal
- Spring-loaded ball to assist ball in seating faster

**Parts List – True Union (Sizes 1/2" - 2")**

PARTS			
NO.	DESCRIPTION	PCS.	MATERIAL
1	Body	1	PVC, CPVC, PP, PVDF
2	Ball	1	PVC, CPVC, PP, PVDF
3	End Connector	2	PVC, CPVC, PP, PVDF
4	Union Nut	2	PVC, CPVC, PP, PVDF
5	Stop Ring (A)	1	PVC, CPVC, PP, PVDF
8	Stop Ring (B)*	1	PVDF
9	Seat	1	EPDM, FKM, PTFE
10	O-Ring	1	EPDM, FKM, PTFE
3a	Ring**	1	Stainless Steel 304

\* Used for flanged end.  
\*\* Used for CPVC body, threaded end; 1/2" - 1".

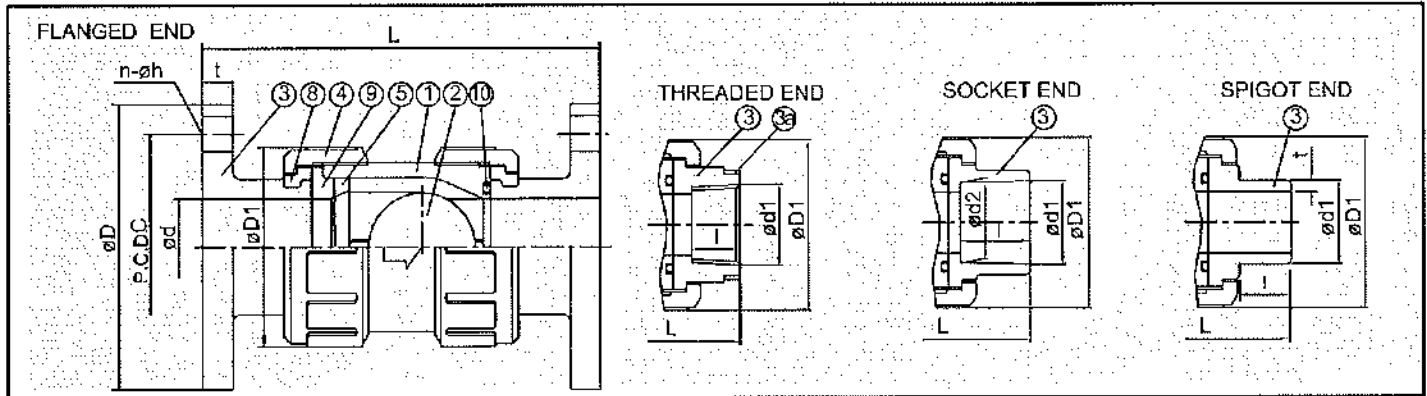

**Dimensions (Sizes 1/2" - 2") (in.)**

NOMINAL SIZE	FLANGED							THREADED							SOCKET							SPIGOT (BUTT END)								
	ANSI CLASS 150														PVC, CPVC			PP, PVDF (DIN)				PP, PVDF (IPS)				PP, PVDF				
															ASTM SCH 80			DIN 16962								DIN 3442			PP	PVDF
	D	C	n	h	L	t		d1	L	L	d	D1	d1	h	L	d1	d2	L	d1	L	d1	L	d1	L	t	t	L			
1/2	15	3.50	2.38	4	0.62	3.12	0.17	1/2 - 14NPT	0.59	3.39	0.59	1.99	0.948	0.836	0.858	3.43	0.768	0.765	0.87	3.19	0.83	0.87	3.31	0.787	0.728	0.068	0.075	4.0		
3/4	20	3.88	2.75	4	0.62	3.10	0.55	3/4 - 14NPT	0.67	4.08	0.79	2.36	1.058	1.040	0.718	3.85	0.985	0.957	0.63	3.70	1.03	1.00	4.43	0.984	0.866	0.106	0.075	4.3		
1	25	4.26	3.12	4	0.62	3.10	0.55	1 - 11-1/2NPT	0.79	4.45	0.98	2.76	1.325	1.310	0.875	4.87	1.240	1.202	0.71	4.10	1.30	1.13	4.35	1.260	0.866	0.118	0.064	4.7		
1 1/4	32	4.84	3.50	4	0.62	3.10	0.55	1 1/4 - 11-1/2NPT	0.87	5.00	1.27	3.78	1.670	1.655	0.938	4.92	-	-	-	-	-	-	-	-	-	-	-	-		
1 1/2	40	5.00	3.88	4	0.62	3.10	0.55	1 1/2 - 11-1/2NPT	0.95	5.84	1.57	3.78	1.912	1.894	1.094	5.94	1.947	1.937	0.93	5.82	1.89	1.57	5.57	1.868	0.866	0.181	0.118	5.7		
2	50	6.00	4.75	4	0.75	3.43	0.63	2 - 11-1/2NPT	1.10	8.87	2.01	4.17	2.367	2.289	1.156	8.77	2.461	2.445	1.06	6.89	2.36	1.50	6.48	2.480	1.417	0.228	0.118	8.5		

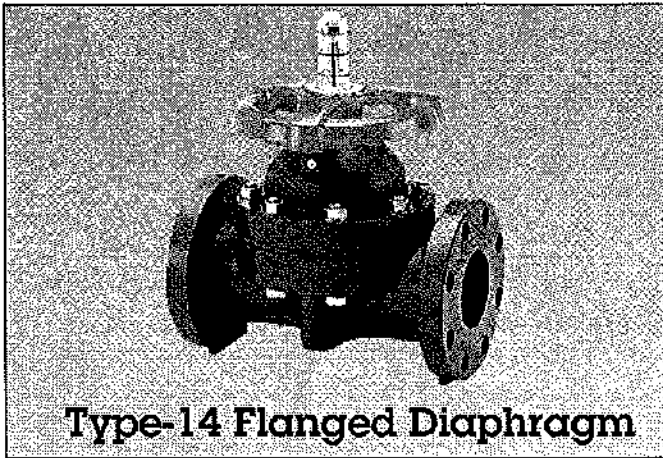

**Type-14 Flanged Diaphragm**

**Standard Features (Sizes 1/2" - 2")**

- Flanged (ANSI) face-to-face dimensions are equivalent to most commonly used metallic valves
- Rugged body and bonnet are of solid thermoplastic for maximum corrosion resistance
- Uniquely designed body and bonnet together with diaphragms of new sealing designs by computer dynamic analysis for superior sealing
- Weir design for excellent throttling
- Bubble-tight sealing, even in applications such as slurries or suspended particles
- Bonnet seals to protect internal from corrosive environments
- Built-in travel stop to prevent overtightening or compressive strain on diaphragm
- Integrally molded bottom stand for simple yet firm panel mounting
- Indicator at the top for indication of valve position and prevention of overtightening
- PVDF gas barrier, which protects EPDM backing from gas permeation, is standard for all valves with PTFE diaphragm
- Low profile
- Bayonet structure to connect compressor and diaphragm - Easy diaphragm replacement

**Options**

- 2" square nut
- Stem extensions (single and two-piece design)
- Locking device for tamper proofing
- Chainwheel operator

**Specifications**

**Sizes:** 1/2" - 4"  
**Body Materials:** PVC, UPVC, PP and PVDF  
**Bonnet Materials:** PVC, PP, PPG and PVDF  
**Diaphragms:** EPDM and 3-Layer EPDM/PVDF/PTFE  
 Also available in Nitrile and FKM

**End Connection:** Flanged  
**Operator:** Handwheel

**Parts Type-14 Flanged (Sizes 1/2" - 2")**

PARTS			
NO.	DESCRIPTION	PCS.	MATERIAL
1	Body	1	<del>PVC, PP, PPG, PVDF</del>
2	Bonnet	1	<del>PVC, PPG, PP, PVDF</del>
3	Diaphragm	1	<del>EPDM, PTFE, FKM</del>
3a	Diaphragm Metal Insert	1	Stainless Steel 304
4	Cushion*	1	EPDM
5	PVDF Gas Barrier*	1	PVDF
6	Compressor	1	PVDF
7	Joint	1	Stainless Steel 304
8	Stem	1	Copper Alloy
9	Sleeve	1	Copper Alloy
10	Hand Wheel	1	PP
11	Gauge Cover	1	PC
12	Name Plate	1	PVC
13	Retaining Ring C Type	1	Stainless Steel 304
14	O-Ring (A)	1	EPDM
15	C-Ring (B)	1	EPDM
16	Thrust Ring (A)	1	UHMWPE
17	Thrust Ring (B)	1	UHMWPE
18	Bolt, Nut, Washer	4 Sets	Stainless Steel 304
20	Stopper (A)	1	Copper Alloy
21	Screw	1	Stainless Steel 304

\* Used on PTFE diaphragm.

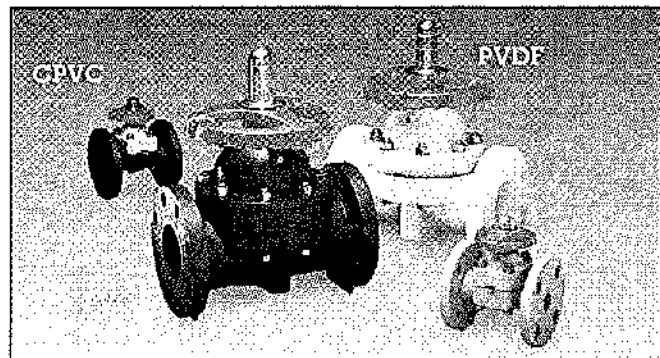



# Type-14 Flanged Diaphragm Valves

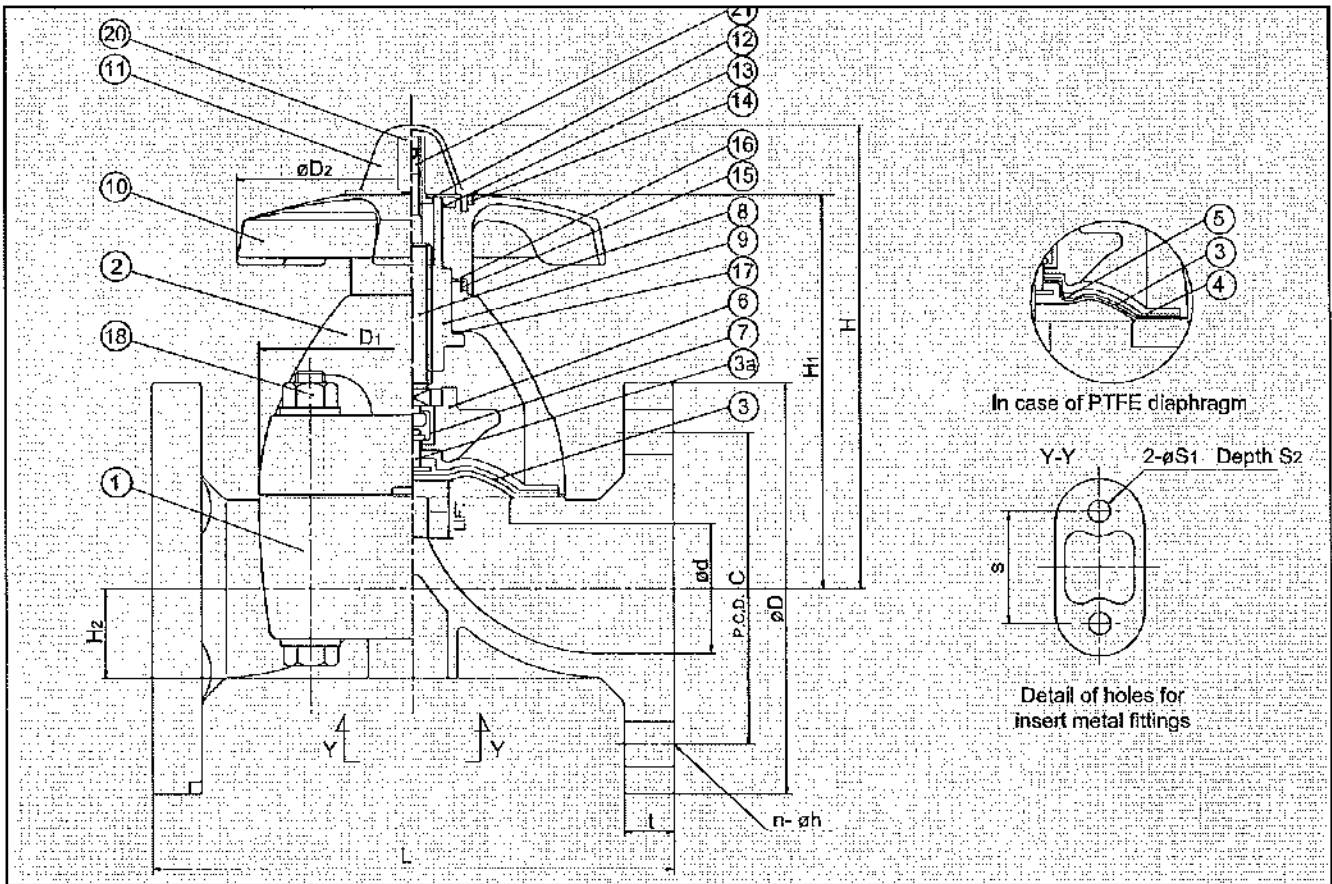

Dimensions Type-14 Flanged (Sizes 1/2" - 2") (in.)

NOMINAL SIZE		ANSI CLASS 150															
INCHES	mm	d	C	D	n	h	D1	D2	L	L	f	H	H1	H2	S	S1	S2
1/2	15	0.63	2.38	3.50	4	0.62	2.13 x 2.60	3.46	0.39	4.25	0.43	4.09	3.39	0.48	0.98	0.28	0.51
3/4	20	0.79	2.75	3.88	4	0.62	2.13 x 2.60	3.46	0.39	5.88	0.51	4.17	3.46	0.57	0.98	0.28	0.51
1	25	0.98	3.12	4.26	4	0.62	2.64 x 3.15	3.46	0.47	5.88	0.59	4.37	3.66	0.73	0.98	0.28	0.51
1-1/4	32	1.26	3.50	4.62	4	0.62	2.64 x 3.15	3.46	0.47	6.38	0.63	4.57	3.82	0.89	0.98	0.28	0.51
1-1/2	40	1.57	3.88	5.00	4	0.62	4.25 x 4.25	6.14	0.63	6.94	0.69	6.97	5.67	1.08	1.77	0.35	0.59
2	50	2.05	4.75	6.00	4	0.75	4.84 x 4.84	6.14	0.88	7.94	0.79	7.52	6.22	1.42	1.77	0.35	0.59

Pressure vs. Temperature psi, water, non-shock

Cv Values /Wt.

NOMINAL SIZE	PVC				CPVC				PP				PVDF				NOMINAL SIZE		Cv	WT. FLG. (lbs)
	ALL DIAPHRAGMS		ALL DIAPHRAGMS		ALL DIAPHRAGMS		ALL DIAPHRAGMS		PTFE DIAPHRAGM				INCHES	mm						
	30° F	106° F	38° F	108° F	141° F	178° F	5° F	106° F	141° F	178° F	40° F	141° F			178° F	211° F				
1/2	15	150	100	150	115	85	40	150	115	85	70	150	120	95	70	1/2	15	4.8	1.50	
3/4	20	150	100	150	115	85	40	150	115	85	70	150	120	95	70	3/4	20	5.3	1.90	
1	25	150	100	150	115	85	40	150	115	85	70	150	120	95	70	1	25	8.5	2.40	
1-1/4	32	150	100	150	115	85	40	150	115	85	70	150	120	95	70	1-1/4	32	11	3.10	
1-1/2	40	150	100	150	115	85	40	150	115	85	70	150	120	95	70	1-1/2	40	26	6.20	
2	50	150	100	150	115	85	40	150	115	85	70	150	120	95	70	2	50	43	8.00	

# Type 14 Flanged

# Diaphragm Valves

## Parts Type 14 Flanged (2-1/2" – 4")

PARTS			
NO.	DESCRIPTION	PCS.	MATERIAL
1	Body	1	PVC, CPVC, PP, PVDF
2	Bonnet	1	PVC, PPG, PP, PVDF
3	Diaphragm	1	EPDM, PTFE, Others
3a	Diaphragm Metal Insert	1	Stainless Steel 304
4	Cushion*	1	EPDM
5	PVDF Gas Barrier*	1	PVDF
6	Compressor	1	PVDF
8	Stem	1	Copper Alloy
8a	Indicating Rod	1	Stainless Steel 304
9	Sleeve	1	Copper Alloy
10	Hand Wheel	1	PP
11	Gauge Cover	1	PC
12	Name Plate	1	PVC
13	Retaining Ring (C Type)	1	Stainless Steel 304
14	O-Ring (A)	1	EPDM
15	O-Ring (B)	1	EPDM
16	Thrust Ring (A)	1	UHMWPE
17	Thrust Ring (B)	1	UHMWPE
18	Bolt, Nut, Washer	4 Sets	Stainless Steel 304
20	Stopper (A)	1	Copper Alloy
88	Grease Nipple	1	Copper Alloy
89	Compressor Pin	1	Stainless Steel 304
90	Stud Bolt, Nut	4 Sets	Stainless Steel 304, Others
94	Metal of Compressor	1	Stainless Steel 304 <sup>1</sup>
1a	Inserted Nut	4	Copper Alloy <sup>2</sup>

\* Used on PTFE diaphragm

<sup>1</sup> Used for PVDF body

<sup>2</sup> Used for PVC, CPVC, PP bodies

## Troubleshooting

### What if fluid leaks when valve is fully closed?

1. Travel stop not set correctly. Adjust it per the Asahi Operation and Maintenance manual.
2. Solids built up inside valve. Clean inside, including weir and diaphragm.
3. Diaphragm and/or weir are worn or damaged. Change the part(s).

### What if valve cannot be fully opened?

1. Diaphragm is not properly engaged with compressor. Check engagement per Operation and Maintenance manual.

### What if fluid leaks to atmosphere?

1. Bonnet bolts not properly torqued. Re-torque according to Operation and Maintenance manual.
2. Line pressure exceeds maximum recommended line pressure. Check or reduce system line pressure.
3. Diaphragm has ruptured or has been chemically attacked. Replace diaphragm.

## Sample Specification

All Type-14 flanged diaphragm valves shall be of solid thermoplastic construction for body and bonnet with molded flanged ends. The valves shall come standard with a position indicator, travel stop (to prevent overtightening) and bonnet O-ring sealing arrangement. The valve shall be weir type with a square bonnet body sealing design and bayonet connection diaphragm (1/2" - 2") or round bonnet body sealing design (2-1/2" - 4"). All PTFE diaphragms shall be supplied with a PVDF gas barrier between the layers of EPDM and PTFE for aggressive chemical service. The face-to-face dimensions shall conform to Type G. PVC conforming to ASTM D1784 Cell Classification 12454-A, CPVC conforming to ASTM D1784 Cell Classification 23567A, PP conforming to ASTM D4101 Cell Classification PP0210B67272, PPG (bonnet only) conforming to ASTM D4101 Cell Classification PP0110M20A21130, and PVDF conforming to ASTM D3222 Cell Classification Type II. PVC, CPVC, PP and PVDF shall be rated to 150psi for elastomeric and PTFE diaphragms at 70° F., as manufactured by Asahi/America, Inc.

FLUOR-O-FLO®  
**PVDF & PTFE Y-Strainers**  
**Removable PTFE Strainer Cartridge with Fluoropolymer Screen**  
**Flanged • NPT • Tri-Clamp • Socket Weld**

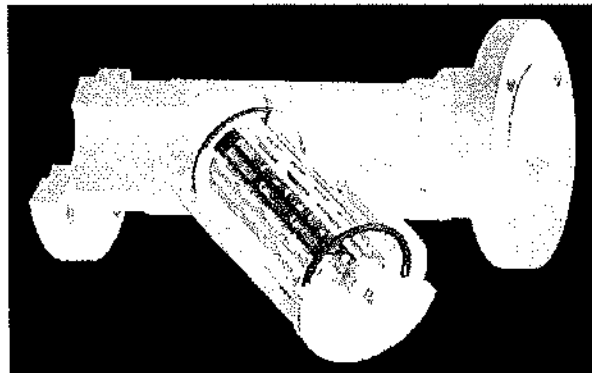

Micromold's Y-Strainers remove particles or debris from process lines handling extremely corrosive or high-purity fluids. To ensure maximum corrosion resistance and purity, all wetted materials are fluoroplastics.

PVDF Y-Strainers are available in 1/8" through 4" and PTFE Y-Strainers are available in 1/8" through 3" pipe sizes.

Easily cleaned, removable PTFE cartridges securely support ETFE screens in standard 11, 17, 30 or 51 mesh sizes. Standard PEEK screens available in mesh sizes ranging from 400 to 65 (12 to 155 microns). Other mesh sizes and types available on special order.

Open area ratio of screen to pipe meets or exceeds 2:1 for all sizes when used with a mesh having a minimum 48% open area.

Standard end connections fit NPT threaded, Tri-Clamp, flanged, and socket- or butt-weld (PVDF only) piping systems. We can provide virtually any connection (True-Union, etc.) on special order.

Units may be installed either horizontally or vertically.

Also available:

FLUOR-O-FLO® PVDF & PTFE Y-Strainers

- Sales Bulletin
- Installation and Maintenance Guide
- Strainer Screens Technical Bulletin



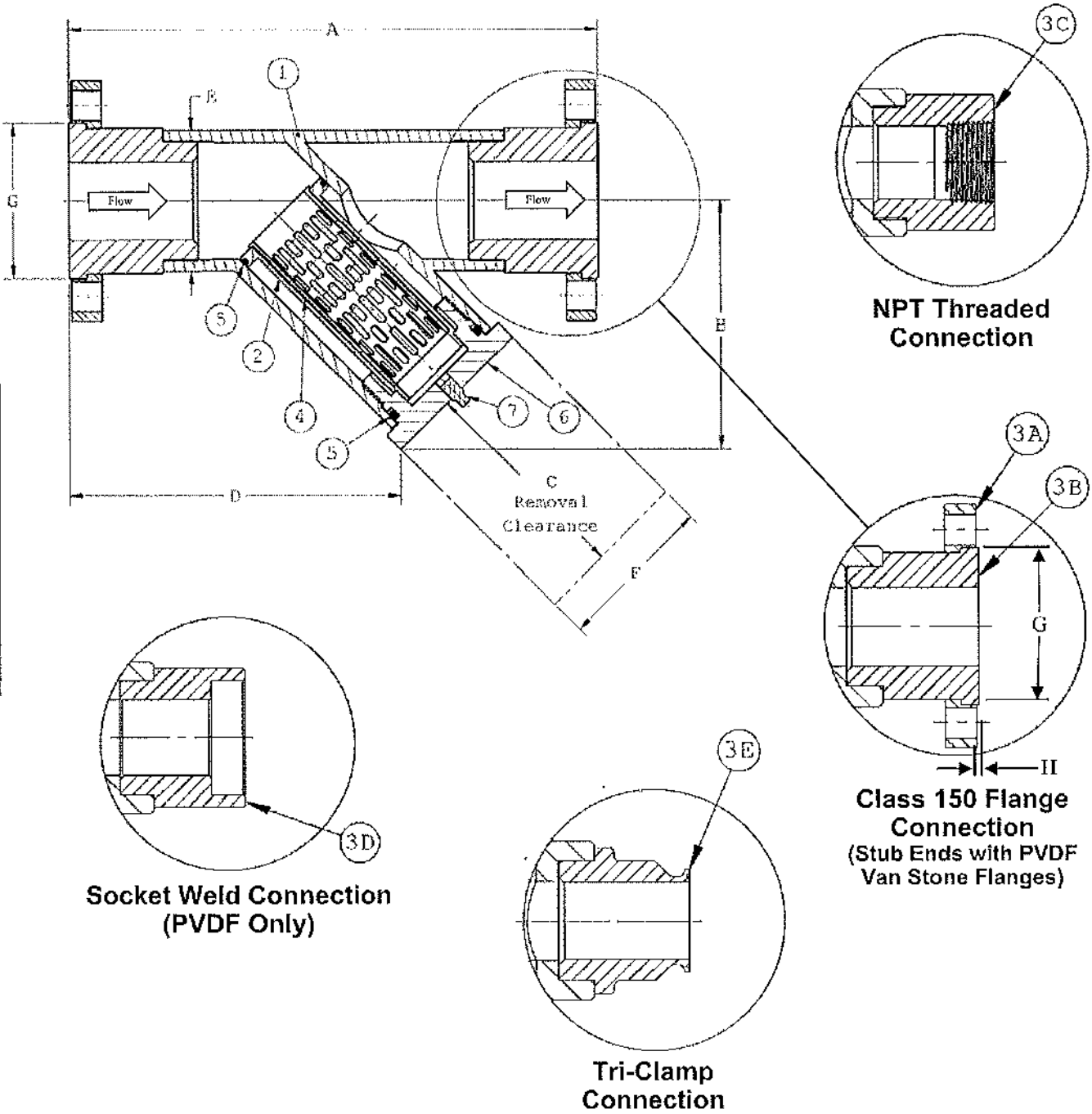

**Connection Availability and Size Ranges**

Strainer Material	NPT	Flanged	Socket Weld	Tri-Clamp
PVDF	<del>1/8" - 4"</del>	<del>1/2" - 4"</del>	<del>3/8" - 4"</del>	<del>1/2" - 4"</del>
PTFE	<del>1/8" - 3"</del>	<del>1/2" - 3"</del>	<del>N/A</del>	<del>1/2" - 3"</del>

All flanges are Van Stone type with stub ends (rotatable)



**Dimensions\***

Nominal Pipe Size	A	B	C	D	E (PVDF)	E (PTFE)	F	G	H	PLUG NPT
<del>1/8</del>	<del>8.3</del>	<del>2.8</del>	<del>2.9</del>	<del>4.7</del>	<del>1.32</del>	<del>1.50</del>	<del>1.60</del>	<del>NA</del>	<del>NA</del>	<del>1/8</del>
<del>1/4</del>	<del>8.3</del>	<del>2.8</del>	<del>2.9</del>	<del>4.7</del>	<del>1.32</del>	<del>1.50</del>	<del>1.60</del>	<del>NA</del>	<del>NA</del>	<del>1/8</del>
<del>3/8</del>	<del>8.3</del>	<del>2.8</del>	<del>2.9</del>	<del>4.7</del>	<del>1.32</del>	<del>1.50</del>	<del>1.60</del>	<del>NA</del>	<del>NA</del>	<del>1/8</del>
<del>1/2</del>	<del>8.3</del>	<del>2.8</del>	<del>2.9</del>	<del>4.7</del>	<del>1.32</del>	<del>1.50</del>	<del>1.60</del>	<del>1.62</del>	<del>0.065</del>	<del>1/8</del>
<del>3/4</del>	<del>9.9</del>	<del>3.5</del>	<del>3.7</del>	<del>5.5</del>	<del>1.90</del>	<del>2.00</del>	<del>2.20</del>	<del>1.99</del>	<del>0.065</del>	<del>1/8</del>
<del>1</del>	<del>9.9</del>	<del>3.5</del>	<del>3.7</del>	<del>5.5</del>	<del>1.90</del>	<del>2.00</del>	<del>2.20</del>	<del>2.37</del>	<del>0.065</del>	<del>1/8</del>
<del>1-1/4</del>	<del>11.1</del>	<del>5.5</del>	<del>5.8</del>	<del>7.4</del>	<del>2.88</del>	<del>2.88</del>	<del>3.00</del>	<del>2.74</del>	<del>0.065</del>	<del>1/8</del>
<del>1-1/2</del>	<del>11.1</del>	<del>5.5</del>	<del>5.8</del>	<del>7.4</del>	<del>2.88</del>	<del>2.88</del>	<del>3.00</del>	<del>3.12</del>	<del>0.065</del>	<del>1/8</del>
<del>2</del>	<del>12.2</del>	<del>6.3</del>	<del>6.2</del>	<del>7.7</del>	<del>3.50</del>	<del>3.75</del>	<del>3.94</del>	<del>3.87</del>	<del>0.065</del>	<del>1/8</del>
<del>3</del>	<del>14.7</del>	<del>8.9</del>	<del>8.7</del>	<del>9.9</del>	<del>5.00</del>	<del>5.25</del>	<del>5.44</del>	<del>5.12</del>	<del>0.065</del>	<del>1/4</del>
<del>4</del>	<del>17.3</del>	<del>11.5</del>	<del>10.7</del>	<del>11.9</del>	<del>6.63</del>	<del>N/A</del>	<del>7.20</del>	<del>6.62</del>	<del>0.065</del>	<del>1/4</del>

\* All dimensions shown in inches

**Construction**

Item No.	PVDF Y-Strainers	PTFE Y-Strainers
1	PVDF Body	MICROFLON™ PTFE Body
2	PTFE Cartridge	PTFE Cartridge
3A	PVDF Flange (Other materials available)	PVDF Flange (Other materials available)
3B	PVDF Stub End	PTFE Stub End
3C	PVDF NPT Connector	PTFE NPT Connector
3D	PVDF Socket Weld Connector	Not Available
3E	PVDF Tri-Clamp Connector	PTFE Tri-Clamp Connector
4	Fluoropolymer Screen	Fluoropolymer Screen
5	FEP Encapsulated Silicone Rubber O-Ring	FEP Encapsulated Silicone Rubber O-Ring
6	PVDF Knurled Cap	PTFE Knurled Cap
7	PTFE Drain Plug	PTFE Drain Plug

**Engineering Specifications**

FLUOR-O-FLO® Y-Strainers shall be (PVDF or virgin PTFE) construction with (socket weld, NPT threaded, Tri-Clamp, or flanged) end connections. The strainers shall have covers removable without the use of tools to facilitate cleaning, and have an FEP encapsulated silicone rubber o-ring seal. Strainer to have a (1/8" or 1/4") NPT removable drain plug. Strainers to have a minimum 2:1 ratio of open area to the size-corresponding cross-sectional pipe area when used with a mesh screen having a minimum open area of 48%. Strainers shall have a removable PTFE strainer cartridge with FEP encapsulated silicone rubber o-ring seal that is secured to and removable with the cover. Strainer cartridges shall have perforated PTFE inner and outer cartridge components to secure screen mesh. As manufactured by MICROMOLD PRODUCTS, INC.



**Michael Bonser**

---

**From:** Boris Petkovic <boris.petkovic@aquang.com>  
**Sent:** Friday, November 8, 2019 8:48 AM  
**To:** Michael Bonser; Dan Dragland  
**Cc:** Blair Kariniemi; Justin Logan; Juan Ahumada  
**Subject:** RE: Beaumont Submittal updates

Dan,  
We are okay for you to proceed in providing an updated cost proposal for the PVDF sulfuric acid skid.  
Thanks.  
Regards,

**Boris Petkovic, PE**  
Project Engineer

AQUA Engineering  
533 W 2600 S Suite 275, Bountiful, UT 84010  
C: 801.386.1502 | D: 801.683.3734  
O: 801.299.1327 | F: 801.299.0153

[aquang.com](http://aquang.com)

NOTICE: This email message is for the sole use of the intended recipient(s) and may contain confidential and privileged information. Any unauthorized review, use, disclosure, or distribution is prohibited. If you are not the intended recipient, please contact the sender by reply email and destroy all copies of the original message. The information transmitted (including attachments) is covered by the Electronics Communications Privacy Act, 18 U.S.C. 2510-2521.

---

**From:** Michael Bonser <mbonser@wmlylesco.com>  
**Sent:** Friday, November 8, 2019 9:23 AM  
**To:** Dan Dragland <Dan.Dragland@h2oinnovation.com>; Boris Petkovic <boris.petkovic@aquang.com>  
**Cc:** Blair Kariniemi <Blair.Kariniemi@h2oinnovation.com>; Justin Logan <justin.logan@aquang.com>; Juan Ahumada <jahumada@wmlylesco.com>  
**Subject:** RE: Beaumont Submittal updates

Dan/Boris,

We would like to formally submit the proposal for the changes to the sulfuric acid system mentioned in the email below. Are we at a point where we can get a formal proposal from H2O? If so, can you please send it over to us.

Thanks,

Michael Bonser | Project Manager  
W. M. LYLES CO. | Southern Division  
42142 Roick Dr. | Temecula, CA 92590  
O 951-973-7393 | C 951-757-2330  
[www.wmlyles.com](http://www.wmlyles.com)

-----  
Please access the hyperlink below for an important electronic communications disclaimer:  
[http://www.lylesgroup.com/disclaimer\\_lsc.html](http://www.lylesgroup.com/disclaimer_lsc.html)  
-----

---

**From:** Dan Dragland <[Dan.Dragland@h2oinnovation.com](mailto:Dan.Dragland@h2oinnovation.com)>  
**Sent:** Thursday, November 7, 2019 7:49 PM  
**To:** Boris Petkovic <[boris.petkovic@aquang.com](mailto:boris.petkovic@aquang.com)>; Justin Logan <[justin.logan@aquang.com](mailto:justin.logan@aquang.com)>; Juan Ahumada

<[jahumada@wmlylesco.com](mailto:jahumada@wmlylesco.com)>; Michael Bonser <[mbonser@wmlylesco.com](mailto:mbonser@wmlylesco.com)>

**Cc:** Blair Kariniemi <[Blair.Kariniemi@h2oinnovation.com](mailto:Blair.Kariniemi@h2oinnovation.com)>

**Subject:** RE: Beaumont Submittal updates

Yes, a protective shield is included on the sulfuric skid.

**Dan Dragland**

Project Manager



Tel.: 760.598.2206 x107

Cell: 760.639.9290

Fax: 760.598.2208

[dan.dragland@h2oinnovation.com](mailto:dan.dragland@h2oinnovation.com)

[www.h2oinnovation.com](http://www.h2oinnovation.com)

1048 La Mirada Court, Vista, CA 92081, United States

---

**From:** Boris Petkovic <[boris.petkovic@aquang.com](mailto:boris.petkovic@aquang.com)>

**Sent:** Thursday, November 7, 2019 4:11 PM

**To:** Dan Dragland <[Dan.Dragland@h2oinnovation.com](mailto:Dan.Dragland@h2oinnovation.com)>; Justin Logan <[justin.logan@aquang.com](mailto:justin.logan@aquang.com)>; Juan Ahumada <[jahumada@wmlylesco.com](mailto:jahumada@wmlylesco.com)>; Michael Bonser <[mbonser@wmlylesco.com](mailto:mbonser@wmlylesco.com)>

**Cc:** Blair Kariniemi <[Blair.Kariniemi@h2oinnovation.com](mailto:Blair.Kariniemi@h2oinnovation.com)>

**Subject:** RE: Beaumont Submittal updates

Thanks Dan.

Does the sulfuric acid skid include the protection cover?

Regards,

**Boris Petkovic, PE**

Project Engineer

AQUA Engineering

533 W 2600 S Suite 275, Bountiful, UT 84010

C: 801.386.1502 | D: 801.683.3734

O: 801.299.1327 | F: 801.299.0153

[aquang.com](http://aquang.com)

NOTICE: This email message is for the sole use of the intended recipient(s) and may contain confidential and privileged information. Any unauthorized review, use, disclosure, or distribution is prohibited. If you are not the intended recipient, please contact the sender by reply email and destroy all copies of the original message. The information transmitted (including attachments) is covered by the Electronics Communications Privacy Act, 18 U.S.C. 2510-2521.

---

**From:** Dan Dragland <[Dan.Dragland@h2oinnovation.com](mailto:Dan.Dragland@h2oinnovation.com)>

**Sent:** Thursday, November 7, 2019 4:51 PM

**To:** Boris Petkovic <[boris.petkovic@aquang.com](mailto:boris.petkovic@aquang.com)>; Justin Logan <[justin.logan@aquang.com](mailto:justin.logan@aquang.com)>; Juan Ahumada <[jahumada@wmlylesco.com](mailto:jahumada@wmlylesco.com)>; Michael Bonser <[mbonser@wmlylesco.com](mailto:mbonser@wmlylesco.com)>

**Cc:** Blair Kariniemi <[Blair.Kariniemi@h2oinnovation.com](mailto:Blair.Kariniemi@h2oinnovation.com)>

**Subject:** Beaumont Submittal updates

All, here are the updates. We will have an updated P&ID and sulfuric skid drawing very soon.

U18865-C01-0001,08 (P&ID's): In progress.

13.

U18865-C05-0001,05 (Equipment list):

<https://h2oinnovation.fileserverapp.com/files/8d4847c25c72702b69d1d810df1e6e3b.pdf>

U18865-C14-0001,05 (Instrument list):

<https://h2oinnovation.fileserverapp.com/files/a085e2982a5a06e8c51696c3331b2cba.pdf>

U18865-C20-0001,06 (Valve list):

<https://h2oinnovation.fileserverapp.com/files/964ec3913e120f35691990112037a5a4.pdf>

U18865-B01-0803,01 (Ammonium sulfate skid):

<https://h2oinnovation.fileserverapp.com/files/96a448ba9b4324fc9939bbeda1f7568e.pdf>

U18865-B01-0802,01 (Sulfuric acid skid): In progress.

U18865-C06-0014,03 (Chemical metering pumps):

<https://h2oinnovation.fileserverapp.com/files/dd85150fa6f197a9a7594bc483d16b52.pdf>

U18865-C06-0013,01 (Calibration column): Approved, no resubmittal required.

The ammonium sulfate skid is virtually identical to the other chemical skids that were already built and delivered. I will confirm once we update the sulfuric drawing if the sulfuric acid skid anchorage remains the same. I see no reason it would change, but since it would be a different skid, we are running it past the structural engineer.

The sulfuric skid that was quoted assumed a concentration of 78%. The CPVC piping and valve/fitting materials for the quoted sulfuric skid have a "fair" rating for 93%-98% sulfuric. That is not to say "unacceptable," but it would be much safer to use PVDF/PFA/Viton (fluoro) materials.

Changing all the valves, fittings and exposed materials would be a change order as fluoro is much more expensive. The amount would not be insignificant. From our review of the material and the amounts of each (valves, fittings), I can say it would be upwards of \$9000. Would that be acceptable?

Dan

**Dan Dragland**

Project Manager



Tel.: 760.598.2206 x107

Cell: 760.639.9290

Fax: 760.598.2208

[dan.dragland@h2oinnovation.com](mailto:dan.dragland@h2oinnovation.com)

[www.h2oinnovation.com](http://www.h2oinnovation.com)

1048 La Mirada Court, Vista, CA 92081, United States





**Technical Justification:**

PCO-29	
Design Adjustment: RFI-094 WML COP-029	Solids Feed Pump TE/TSH Thermocouple Elements
<p>Engineer response to RFI-094 confirmed that thermocouple temperature elements are required on the motors of the Solids Feed Pumps for monitoring pump flow and motor status. Contract Specification did not require these pump motors to include temperature sensors.</p> <p><u>Design and Scope Changes:</u></p> <ul style="list-style-type: none"> <li>• Temperature elements for monitoring the pump stator temperature and are to be tied into plant SCADA as shown on PI-20. These elements and associated controllers should be provided by the pump supplier.</li> <li>• Note that the contract documents (PI-20, E-24, CE-08 and CE-19) shows the contractor’s responsibility for connecting these elements to the LCPS and the only change to the work is the inclusion of the temperature elements and controllers from the pump supplier).</li> </ul> <p><u>Cost Impact:</u></p> <p>MWHC recommends a contract cost increase of \$2,354.10 to be executed in a change order for changes to the motors of the Solids Feed Pumps.</p>	

CITY OF BEAUMONT WWTP SALT MITIGATION UPGRADE PROJECT

CHANGE ORDER PROPOSAL (COP) # 029  
(By Contractor)

<b>To (Engineer/CM):</b> MWH Constructors Attention: Charles Reynolds Phone: 702-497-8024 Email: Charles.w.reynolds@mwhconstructors.com	<b>From (Contractor):</b> W.M. Lyles Co. Attention: Juan C. Ahumada Phone: 951-972-2056 Email: jahumada@wmlylesco.com
<b>PCO/DCM No.:</b> RFI #094	
<b>Subject:</b> Solids Feed Pump TE/TSHs	
<b>Reference Documents:</b> RFI #094	
<b>DESCRIPTION</b>	
Please review the attached change order proposal associated with the added TEs and their corresponding TSHs for the solids feed pumps as referenced in RFI #094.  This proposal is valid for 30 days.	
<b>COST ESTIMATE</b>	
Total Cost \$ 2,354.10, see attached breakdown.	
<b>SCHEDULE IMPACT</b>	
None	
<b>Received by MWH Constructors (Date):</b>	

**RESPONSE**

--

**Response By:**

**Date:**

Final Distribution: Juan C. Ahumada, W.M. Lyles Co.  
Brian Knoll, Webb Associates  
MWH Inspector

W. M. Lyles Co.  
 42142 Roick Drive  
 Temecula, CA 92590

Date: 21-Nov-19

Reference #: RFI #094

Attention: Charles W. Reynolds

JOB LOCATION: City of Beaumont WWTP Slat Mitigation Upgrade Project

DESCRIPTION: Solids Feed Pumps TE/TSHs

Item:	Unit	Total MH	Total MH Cost	Eq. Cost	Material	Subcont.	Total Cost
1 Solids Feed Pumps TE/TSHs	LS	0	\$ -	\$ -	\$ 2,026.78	\$ -	\$ 2,026.78
Total Costs		0	\$ -	\$ -	\$ 2,026.78	\$ -	\$ 2,026.78

Subtotal		\$ 2,026.78
Mark-up - Labor	15%	\$ -
Mark-up - Equipment	15%	\$ -
Mark-up - Materials	15%	\$ 304.02
Mark-up - Subcontractor	5%	\$ -
Bond	1.0%	\$ 23.31
<b>Total This Change Order</b>		<b>\$ 2,354.10</b>

Comments:



**CONTRACTOR'S REQUEST FOR INFORMATION (RFI) #094**

<b>To (Engineer):</b> MWH Constructors Attention: Charles Reynolds Phone: 702-497-8024 Email: Charles.w.reynolds@stantec.com	
<b>From (Contractor):</b> W.M. Lyles Co. Attention: Michael Bonser Phone: 951-757-2330 Email: mbonser@wmlylesco.com	
<b>Subject:</b> Solids Feed Pumps TE/TSHs	
<b>Reference:</b> E-24, PI-20	<b>Specification (Section and Page):</b> 432357
<b>REQUEST</b>	
<b>Information is requested as follows:</b>	
<p>P&amp;ID drawing PI-20 shows temperature elements TE-8101, 8102 &amp; 8103 on the solids feed pumps. Each TE has a corresponding TSH in LCP-8101. Drawing E-24 shows a signal coming from a “pump bearing thermocouple” going to a thermocouple controller inside of LCP-8101.</p> <p>Specification section 432357 does not provide any information on the TEs or corresponding TSHs for the sludge pumps. Please provide a specification or information on these items and clarify the purpose of them.</p>	
<b>Information Requested By (Name):</b> W.M. Lyles Co.	<b>Date:</b> 09/25/2019
<b>Response Requested By (Date):</b> 10/02/2019	
<b>Received by CM (Date):</b>	
<b>RESPONSE</b>	
<b>Response to Information Request:</b>	
<p>The temperature elements shown are for monitoring the pump stator temperature and are to be tied into plant SCADA as shown on PI-20. These elements and associated controllers should be provided by the pump supplier. See the attached cutsheets for reference in specifying the equipment.</p> <p>Note that the contract documents (PI-20, E-24, CE-08 and CE-19) shows the contractor’s responsibility for connecting these elements to the LCPS and the only change to the work is the inclusion of the temperature elements and controllers from the pump supplier.</p>	
<b>Response By (Name):</b> D. Stephens, AQUA Engineering	<b>Date:</b> 10/7/19

Final Distribution:

October 31, 2019

**To: WMLYLES CO**  
**42142 RIOCK DR.**  
**TEMECULA, CA 92590**  
**ATTN: ADAM HICKMAN**  
[ahickman@wmlylesco.com](mailto:ahickman@wmlylesco.com)

**VIA: EMAIL**

**Re: BEAUMONT, CITY OF**  
**SALT MITIGATION PROJ.**

**Bid Date:** 8/1/18 @ 3 PM

Dear Adam,

We are pleased to offer the following for your consideration:

<u>ITEM</u>	<u>SECTION</u>	<u>DESCRIPTION</u>	<u>PRICE</u>
4	432357	<p align="center"><b>PROGRESSING CAVITY PUMPS</b>  <b><u>ADDER FOR RUN DRY PROTECTION</u></b></p> <p><i>Run Dry Protection consists of a temperature prove mounted in the stator and a temperature controller Omron E5CSV-RIT provided loose for customer to mount in their control panel.</i></p> <p>Three (3) units of cast iron construction, 1800 RPM, TEFC Motor, Class F insulation, rated for 250gpm @ 50psi, in line base plate mounted, Start Up and Training Assistance as manufactured by <b>NETZSCH</b>. Please see the attached manufacturers' scope letter for details.</p>	\$1,881.00

Note:

**GENERAL NOTES:**

1. No taxes included in above pricing
2. Pricing valid for thirty (30) days from date of bid.





3. Price is F.O.B. factory with freight to jobsite included. Freight charges cannot be broken out of pricing.
4. Proposal subject to GMI Terms & Conditions attached and/or terms and conditions of individual companies quoted.
5. If this proposal makes reference to certain section numbers in the specifications, these are listed for reference only. We will not be responsible for furnishing all the equipment in these sections, but only that equipment which is specifically listed in our proposal; nor will we furnish any items of equipment which are omitted from the engineer's drawings or specifications unless specifically listed in our proposal.
6. It is the contractor's responsibility to thoroughly review the individual supplier's scope letters to ensure that they are in compliance with the specifications and all addenda. Neither Gierlich-Mitchell, Inc., nor their suppliers will be held responsible for any deficiencies between the manufacturer's proposal and the specifications, including all addenda.

Thank you for giving us the opportunity to quote you on this project. If you have any comments or questions, please feel free to contact our office at (714) 236-6070.

Respectfully yours,  
**GIERLICH-MITCHELL, INC.**

Tim Brekke  
Sales Engineer

**TERMS AND CONDITIONS OF SALE**

Proposal No.

- 1. ACCEPTANCE.** This proposal is submitted to Purchaser subject to the terms and conditions hereinafter set forth. There are no agreements or representations, verbal or otherwise, outside of this proposal. Upon the acceptance hereof by Purchaser by signing an acceptance copy of this proposal and returning the same to Seller and upon execution of this proposal by an authorized representative of Seller, this proposal shall become a binding contract
- 2. DELIVERIES.** GIERLICH-MITCHELL, Inc. shall not be liable for delays in delivery due to fire, flood, natural causes, labor trouble (including strikes, slowdowns and lockouts), war, Government regulation, riot, civil disorders, interruption of or delay in transportation, power failure, inability to obtain materials and supplies, accidents, acts of God, or any other cause beyond Seller's reasonable control. Please let us know the delivery date required for this equipment. We will process this order using all means possible to insure "on time" delivery. Any information regarding delays in your schedule that will affect our equipment, must be made available to us. In most instances, our factories can delay shipment of equipment within reasonable limits to meet a revised schedule. Job delay information not passed on to us in time for us to reschedule delivery will not be considered sufficient cause to delay payment to us. If shipment is delayed at request of Purchaser or by Governmental actions, payment becomes due when the factory is ready to make shipment.
- 3. PAYMENT.** Terms are 15% upon submittal approval, 85% Net 30 days from date of shipment invoice. Interest charges of 1.5% per month will be added to any past due invoices. Seller may ship on a "when ready" basis and partial invoice that equipment shipped. Partial invoices are bound by the same terms and conditions as those invoices submitted upon complete shipment of equipment.
- 4. BACKCHARGES** not authorized by GIERLICH-MITCHELL, INC. written purchase order will not be honored.
- 5. RETENTIONS** not previously approved in writing by GIERLICH-MITCHELL, INC. will not be honored.
- 6. RESPONSIBILITY.** GIERLICH-MITCHELL, INC. shall not be responsible for damage to equipment if misused, stored or improperly installed. GIERLICH-MITCHELL, INC. SHALL NOT BE LIABLE FOR CONSEQUENTIAL, LIQUIDATED OR OTHER SPECIAL DAMAGES, CONSEQUENTIAL DAMAGES FOR THE PURPOSES OF THIS AGREEMENT SHALL INCLUDE BUT NOT BE LIMITED TO, LOSS OF USE, INCOME OR PROFIT, OR LOSS OF DAMAGE TO PROPERTY (INCLUDING, BUT WITHOUT LIMITATION, PRODUCTS MANUFACTURED, PROCESSED OR TRANSPORTED BY THE USE OF THE EQUIPMENT) OCCASIONED BY OR ARISING OUT OF THE OPERATION, USE, INSTALLATION, REPAIR OR REPLACEMENT OF THE EQUIPMENT OR OTHERWISE. Breach of any term or condition of this contract shall not be deemed to invalidate the remainder of this contract.
- 7. WARRANTY.** For benefit of the original user, GIERLICH-MITCHELL, INC., warrants all new equipment to be free from defects in material and workmanship; and will replace or repair, F.O.B. at its factories or other location designated by it, any part or parts returned to it which GIERLICH-MITCHELL, Inc. examination shall show to have failed under normal use and service by the original user within one year following initial shipment to the Purchaser. This warranty does not cover parts damaged by maintenance, installation, modification or adjustment. Such repair or replacement shall be free of charge for items except for those items that are consumable and normally replaced during maintenance.

THIS WARRANTY IS EXPRESSLY MADE BY GIERLICH-MITCHELL, INC. AND ACCEPTED BY PURCHASER IN LIEU OF ALL OTHER WARRANTIES, WHETHER WRITTEN, ORAL, EXPRESS, IMPLIED OR STATUTORY.

This warranty shall not apply to equipment or parts thereof which have been altered or repaired without GIERLICH-MITCHELL, INC. authorization or damaged by improper installation or application, or subject to misuse, abuse, neglect or accident. This warranty applies only to equipment manufactured and sold by GIERLICH-MITCHELL, INC. In cases where equipment is manufactured by others, the manufacturer's warranty shall take precedence.

- 8. TAXES.** Prices are exclusive of all taxes, federal, state, local of any kind of nature.
- 9. PRICE PROTECTION.** Unless otherwise set forth herein, prices are firm based upon the following conditions:
- Receipt of a valid order within thirty (30) days from date or proposal.
  - Receipt of drawings and specifications necessary to proceed within one week of purchase order.
  - Receipt of customer's complete written approval and release for production within four weeks after approval drawings are submitted by GIERLICH-MITCHELL, INC.

Prices will be increased a maximum of one percent per month for any additional time required by contractor.

**10. TRANSPORTATION.** Unless otherwise set forth herein, all prices are F.O.B. our factories with full freight allowed. The consignee must report all claims for damages in transit to the carrier.

**11. COMPLIANCE WITH LAWS.** Purchaser shall be solely responsible for securing any necessary permits under and for compliance with all safety, health, sanitation and other laws, ordinances and regulations in connection with the installation and operation of the equipment.

**12. INDEMNIFICATION.** It is understood that Seller has relied upon data furnished by and on behalf of Purchaser with respect to the safety aspects of the equipment and that is Purchaser's responsibility to assure that the equipment will, when installed and put in use, be in compliance with safety requirements fixed by law and otherwise legally adequate to safeguard against injuries or damage to persons or property. Purchaser hereby agrees to defend, indemnify and hold harmless Seller, its' agents and employees, against any and all losses, costs, damages, claims, liabilities or expenses, including but not limited to reasonably attorney's fees arising out of or use or operation of the same, except claims for repair or replacement of defective parts as provided in Paragraph 7 hereof.

**13. RETURN GOODS.** Goods may not be returned without previous written permission. Returned material must be sent prepaid and is subject to a re-stocking charge.

**14. CANCELLATION.** The purchaser may cancel his order only upon written notice and payment of reasonable cancellation charges, taking into account expenses, commitments already made, and anticipated profit.

**15. TITLE.** Title to equipment specified herein, and to any and all additions and accessories thereto and substitutions therefore, shall remain with Seller until the purchase price thereof is paid in full.

**16. LIEN INFORMATION.** Please provide if applicable.



This signed acceptance of this quotation constitutes a contract and order to purchase in accordance with all Terms and Conditions referred to herein. Buyers purchase order is acceptable, providing purchase order references Terms and Conditions contained herein.

**Project:** BEAUMONT, CITY OF- SALT MITIGATION PROJ.

Accepted: \_\_\_\_\_

Accepted: Gierlich-Mitchell, Inc

Signature: \_\_\_\_\_

Signature: \_\_\_\_\_

By: \_\_\_\_\_

By: \_\_\_\_\_

Date: \_\_\_\_\_

Date: \_\_\_\_\_

## STP3 TEMPERATURE PROBE



The Temperature Sensors is a sensor element PT100 that converts the temperature of the fluid into an electrical signal.

Temperature Sensor - PT100

Characteristics:

Construction: 316 stainless steel rod.

Temperature ranges: -50 ... + 250 ° C.

Electrical connection: DIN 43650 connector

Electrical Terminal: 3 Wire

Sensor element: PT100

Accuracy: Class A

Protection: IP-65

Advantages

High reliability.

Construction and optional special assemblies.

Transmitter in the head.

Thread as specified.

Applications

Temperature measurement in industrial processes.

# Temperature Controllers

# E5CSV

13.

CSM\_E5CSV\_DS\_E\_7\_3

## Easy Setting Using DIP Switch and Simple Functions in DIN 48 × 48 mm-size Temperature Controllers

- Easy setting using DIP switch.
- Models with two alarms added to Series, ideal for temperature alarm applications.
- Universal-input (thermocouple/platinum resistance thermometer) models also available.
- Clearly visible digital display with character height of 13.5 mm.
- Models available with black in addition to white cases.
- RoHS compliant.



For the most recent information on models that have been certified for safety standards, refer to your OMRON website.

 Refer to *Safety Precautions for All Temperature Controllers*.

Refer to *E5CS/E5CSV Operation* for operating procedures.

## Model Number Structure

### ■ Model Number Legend

#### Models with Terminal Blocks

E5CSV-□□□□-□  
1 2 3 4 5

#### 1. Control Outputs

- R: Relay
- Q: Voltage for driving SSR

#### 2. Alarm Outputs

- Blank: No alarm
- 1: 1 alarm
- 2: 2 alarms

#### 3. Input

- KJ: Thermocouple
- P: Platinum resistance thermometer
- T: Thermocouple/platinum resistance thermometer (universal-input)

#### 4. Power Supply Voltage

- Blank: 100 to 240 VAC
- D: 24 VAC/VDC

#### 5. Case Color

- Blank: Black
- W: Light gray

**Note:** A functional explanation is provided here for illustration, but models are not necessarily available for all possible combinations. Refer to *Ordering Information* when ordering.

#### Examples

- Relay control output, without alarm, thermocouple input, light gray case: E5CSV-RKJ-W
- Relay control output, one alarm output, platinum resistance thermometer input, black case: E5CSV-R1P-W



## Ordering Information

### ■ List of Models

**Case Color: Light Gray, Thermocouple or Platinum Resistance Thermometer,  
Power Supply Voltage: 100 to 240 VAC**

Size	Type	Control modes	Alarms	Outputs	Model with thermocouple	Model with platinum resistance thermometer
E5CSV 48 x 48mm	Terminal block	ON/OFF or PID	1	Relay	E5CSV-R1KJ-W	E5CSV-R1P-W
				Voltage (for driving SSR)	E5CSV-Q1KJ-W	E5CSV-Q1P-W

**Case Color: Light Gray, Thermocouple, Power Supply Voltage: 24 VAC/VDC**

Size	Type	Control modes	Alarms	Outputs	Model with thermocouple
E5CSV 48 x 48mm	Terminal block	ON/OFF or PID	1	Relay	E5CSV-R1KJD-W

**Case Color: Light Gray, Universal-input, Power Supply Voltage: 100 to 240 VAC**

Size	Type	Control modes	Alarms	Outputs	Model with universal-input (thermocouple or platinum resistance thermometer)
E5CSV 48 x 48mm	Terminal block	ON/OFF or PID	0	Relay	E5CSV-RT
				Voltage (for driving SSR)	E5CSV-QT
			1	Relay	E5CSV-R1T
				Voltage (for driving SSR)	E5CSV-Q1T
			2 (See note.)	Relay	E5CSV-R2T
				Voltage (for driving SSR)	E5CSV-Q2T

**Note:** There is no alarm output 2 mode switch. The default setting for alarm output 2 is for the upper limit alarm mode. To change the setting, change the alarm type for alarm output 2 in initial setting level 5. For details, refer to the "E5CSV/E5CS-U Digital Temperature Controller User's Manual" (Cat. No. H140-E1-01).

**Case Color: Black, Universal-input, Power Supply Voltage: 24 VAC/VDC**

Size	Type	Control modes	Alarms	Outputs	Model with universal-input (thermocouple or platinum resistance thermometer)
E5CSV 48 x 48mm	Terminal block	ON/OFF or PID	0	Relay	E5CSV-RTD
				Voltage (for driving SSR)	E5CSV-QTD
			1	Relay	E5CSV-R1TD
				Voltage (for driving SSR)	E5CSV-Q1TD
			2 (See note.)	Relay	E5CSV-R2TD
				Voltage (for driving SSR)	E5CSV-Q2TD

**Note:** There is no alarm output 2 mode switch. The default setting for alarm output 2 is for the upper limit alarm mode. To change the setting, change the alarm type for alarm output 2 in initial setting level 5. For details, refer to the "E5CSV/E5CS-U Digital Temperature Controller User's Manual" (Cat. No. H140-E1-01).

### ■ Accessories (Order Separately)

#### Protective Cover

Type	Model
Hard Protective Cover	Y92A-48B

#### Terminal Cover

Model
E53-COV10

#### Terminal Cover

(For Controllers after the design change scheduled for October 2010)

Model
E53-COV17

**Note:** The E53-COV10 Terminal Cover cannot be mounted to Controllers that are manufactured after the design change scheduled for October 2010

#### DIN Track Mounting Adapter

Model
Y92F-52

#### Rubber Packing

Model
Y92S-29

**Note:** The Rubber Packing is provided with the Digital Controller.

# Specifications

## ■ Ratings

Supply voltage	100 to 240 VAC, 50/60 Hz 24 VAC, 50/60 Hz; 24 VDC
Operating voltage range	85% to 110% of rated supply voltage
Power consumption	100 to 240 VAC: 5 VA 24 VAC: 3 VA, 24 VDC: 2 W
Sensor input	Thermocouple input type: K, J, L Platinum resistance thermometer input type: Pt100, JPt100 Universal-input (thermocouple/platinum resistance thermometer) type: K, J, L, T, U, N, R, Pt100, JPt100
Control output	Relay output Voltage output (for driving the SSR)
	SPST-NO, 250 VAC, 3A (resistive load) 12 VDC, 21 mA (with short-circuit protection circuit)
Control method	ON/OFF or 2-PID (with auto-tuning)
Alarm output	SPST-NO, 250 VAC, 1A (resistive load)
Setting method	Digital setting using front panel keys
Indication method	7-segment digital display (character height: 13.5 mm) and deviation indicators
Other functions	<ul style="list-style-type: none"> <li>• Setting change prohibit (key protection)</li> <li>• Input shift</li> <li>• Temperature unit change (°C/°F)</li> <li>• Direct/reverse operation</li> <li>• Temperature range, Sensor switching (K/J/L, Pt100/JPt100)</li> <li>• Switching is performed between a thermocouple and platinum resistance thermometer for universal-input models.</li> <li>• Control period switching</li> <li>• 8-mode alarm output</li> <li>• Sensor error detection</li> </ul>
Ambient operating temperature	-10 to 55°C (with no condensation or icing); with 3-year guarantee: -10 to 50°C
Ambient operating humidity	25% to 85%
Storage temperature	-25 to 65°C (with no condensation or icing)

Note: 1. Do not use an inverter output as the power supply. (Refer to *Safety Precautions for All Temperature Controllers*.)  
2. Models for 24 VAC/DC can also be manufactured.

## ■ Characteristics

Setting accuracy	Thermocouple (See note 1.): (±0.5% of indication value or ±1°C, whichever is greater) ±1 digit max. Platinum resistance thermometer (See note 2.): (±0.5% of indication value or ±1°C, whichever is greater) ±1 digit max.	
Indication accuracy (ambient temperature of 23°C)		
Influence of temperature	R thermocouple inputs: (±1% of PV or ±10°C, whichever is greater) ±1 digit max. Other thermocouple inputs: (±1% of PV or ±4°C, whichever is greater) ±1 digit max.	
Influence of voltage	Platinum resistance thermometer inputs: (±1% of PV or ±2°C, whichever is greater) ±1 digit max.	
Hysteresis (for ON/OFF control)	0.2% FS (0.1% FS for universal-input (thermocouple/platinum resistance thermometer) models)	
Proportional band (P)	1 to 999°C (automatic adjustment using auto-tuning/self-tuning)	
Integral time (I)	1 to 1,999 s (automatic adjustment using auto-tuning/self-tuning)	
Derivative time (D)	1 to 1,999 s (automatic adjustment using auto-tuning/self-tuning)	
Alarm output range	Absolute-value alarm: Same as the control range Other: 0 to input setting range full scale (°C or °F) Alarm hysteresis: 0.2°C or °F (fixed)	
Control period	2/20 s	
Sampling period	500 ms	
Insulation resistance	20 MΩ min. (at 500 VDC)	
Dielectric strength	2,000 VAC, 50/60 Hz for 1 min between current-carrying terminals of different polarity	
Vibration resistance	Malfunction	10 to 55 Hz, 20 m/s <sup>2</sup> for 10 min each in X, Y, and Z directions
	Destruction	10 to 55 Hz, 0.75-mm single amplitude for 2 hr each in X, Y, and Z directions
Shock resistance	Malfunction	100 m/s <sup>2</sup> min., 3 times each in 6 directions
	Destruction	300 m/s <sup>2</sup> min., 3 times each in 6 directions
Life expectancy	Electrical	100,000 operations min. (relay output models)
Weight	Approx. 120 g (Controller only)	
Degree of protection	Front panel: Equivalent to IP66; Rear case: IP20; Terminals: IP00	
Memory protection	EEPROM (non-volatile memory) (number of writes: 1,000,000)	
EMC	EMI Radiated:	EN 55011 Group 1 Class A
	EMI Conducted:	EN 55011 Group 1 Class A
	ESD Immunity:	EN 61000-4-2: 4 kV contact discharge (level 2) 8 kV air discharge (level 3)
	Radiated Electromagnetic Field Immunity:	EN 61000-4-3: 10 V/m (80-1000 MHz, 1.4-2.0 GHz amplitude modulated) (level 3) 10 V/m (900 MHz pulse modulated)
	Conducted Disturbance Immunity:	EN 61000-4-6: 3 V (0.15 to 80 MHz) (level 2)
	Noise Immunity (First Transient Burst Noise):	EN 61000-4-4
	Burst Immunity:	2 kV power-line (level 3), 1 kV I/O signal-line (level 3)
	Surge Immunity:	EN 61000-4-5: Power line: Normal mode 1 kV; Common mode 2 kV Output line (relay output): Normal mode 1 kV; Common mode 2 kV
Voltage Dip/Interrupting Immunity:	EN 61000-4-11 0.5 cycle, 100% (rated voltage)	
Approved standards	UL 61010-1 (listing) CSA C22.2 No.1010-1	
Conformed standards	EN 61326, EN 61010-1, IEC 61010-1 VDE 0106 Part 100 (finger protection), when the terminal cover is mounted.	

Note: 1. The following exceptions apply to thermocouples.  
• U, L: ±2°C ±1 digit max.  
• R: ±3°C ±1 digit max. at 200°C or less  
2. The following exceptions apply to platinum resistance thermometers.  
Input set values 0, 1, 2, 3 for E5CSV: 0.5% FS ±1 digit max.



## Temperature Range

### Thermocouple Input Models

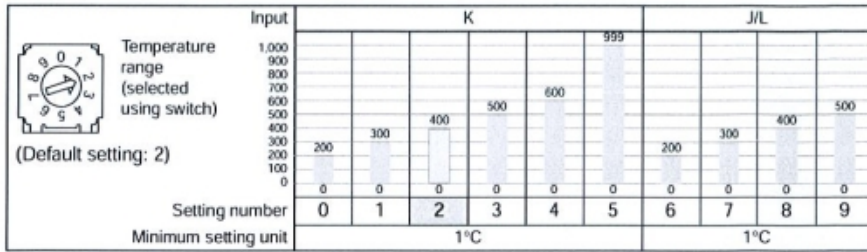

The shaded value indicates the default setting status.

### Platinum Resistance Thermometer Input Models

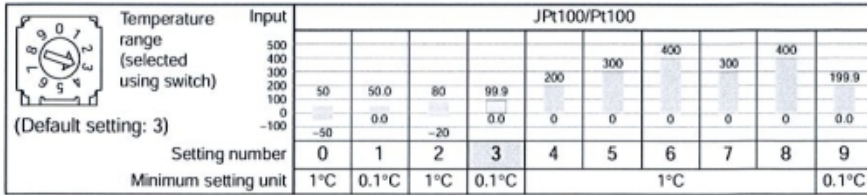

The shaded value indicates the default setting status.

### Universal-input (Thermocouple/Platinum Resistance Thermometer) Models

- Using Thermocouple Sensors, Control Mode Switch 5: OFF

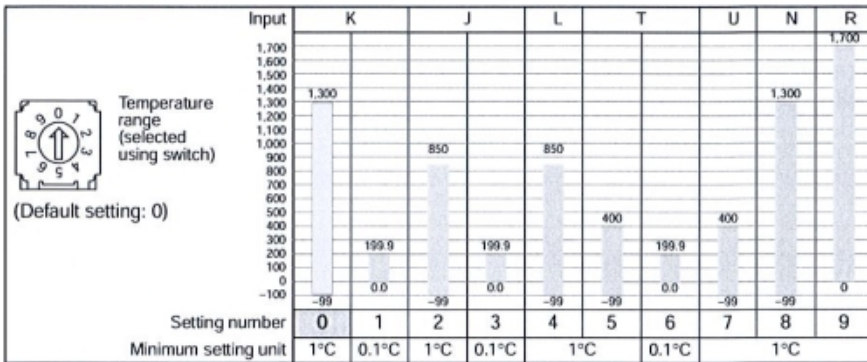

The shaded value indicates the default setting status.

- Using Platinum Resistance Thermometers, Control Mode Switch 5: ON

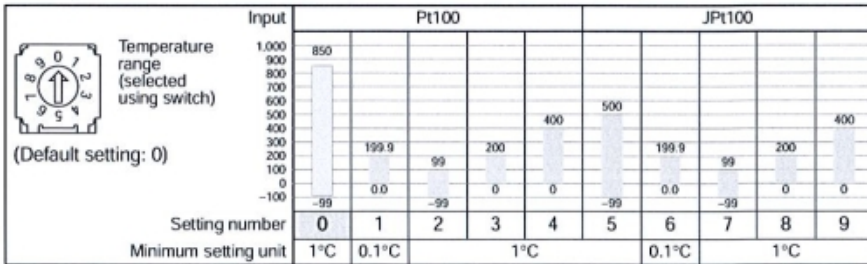

The shaded value indicates the default setting status.

## External Connection Diagram

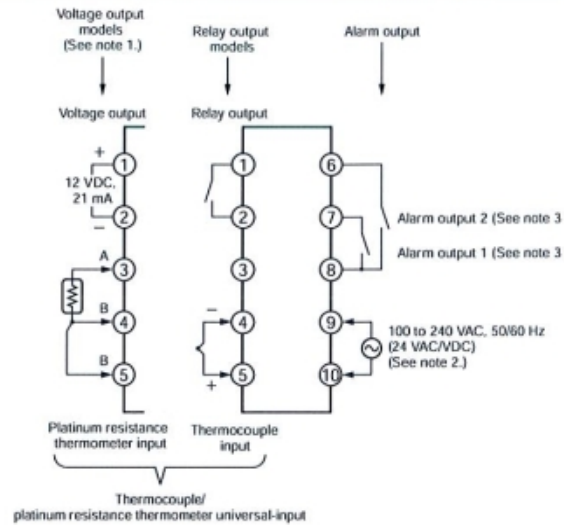

- Note:**
1. The voltage output (12 VDC, 21 mA) is not electrically isolated from the internal circuits. When using a grounding thermocouple, do not connect output terminals 1 or 2 to ground. Otherwise, unwanted current paths will cause measurement errors.
  2. Models with 100 to 240 VAC and 24 VAC/VDC are separate. Models using 24 VDC have no polarity.
  3. The number of alarm outputs depends on the model.

## Nomenclature

### E5CSV Models with Terminal Blocks



# Dimensions

Note: All units are in millimeters unless otherwise indicated.

## Controller

E5CSV

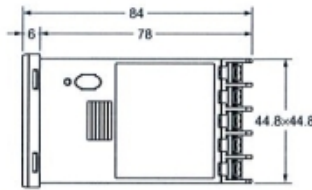

Panel Cutout Dimensions

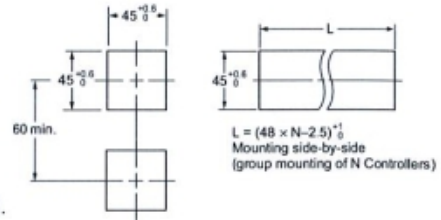

Note: Terminals cannot be removed.

### E5CSV + Adapter for Flush Mounting (Provided)

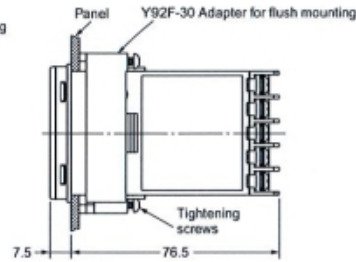
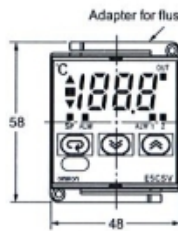

- Note: 1. The recommended panel thickness is 1 to 4 mm.
- 2. Group mounting is possible in one direction only.

### DIN Track Mounting Adapter

Y92F-52 Note: This Adapter cannot be used together with the Terminal Cover. Remove the Terminal Cover to use the Adapter.

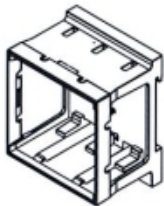

Mounted to E5CSV

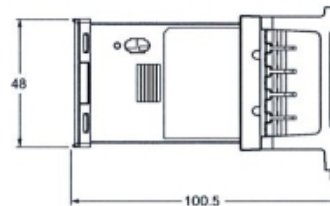
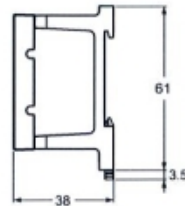

## ■ Accessories (Order Separately)

### Hard Protective Cover

The Y92A-48B Protective Cover (hard type) is available for the following applications.

- To protect the set from dust and dirt.
- To prevent the panel from being accidentally touched causing displacement of set values.
- To provide effective protection against water droplets.



### Terminal Cover

#### E53-COV10

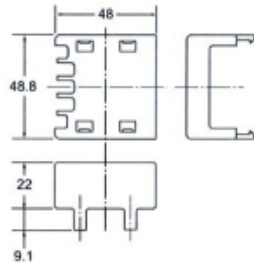

#### E53-COV17

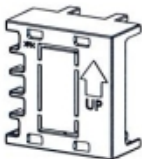

(For Controllers after the design change scheduled for October 2010)

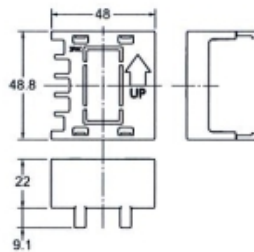

### Rubber Packing

#### Y92S-29 (for DIN48 × 48)



Order the Rubber Packing separately if it becomes lost or damaged. The Rubber Packing can be used to achieve an IP66 degree of protection for models with terminal blocks.

(Deterioration, shrinking, or hardening of the rubber packing may occur depending on the operating environment. Therefore, periodic replacement is recommended to ensure the level of waterproofing specified in NEMA4. The time for periodic replacement depends on the operating environment. Be sure to confirm this point at your site. Consider one year a rough standard. OMRON shall not be liable for the level of water resistance if the customer does not perform periodic replacement.)

The Rubber Packing does not need to be attached if a waterproof structure is not required.

## Safety Precautions

Refer to *Safety Precautions for All Temperature Controllers*.

Refer to *E5CS/E5CSV Operation* for operating procedures.

ALL DIMENSIONS SHOWN ARE IN MILLIMETERS.

To convert millimeters into inches, multiply by 0.03937. To convert grams into ounces, multiply by 0.03527.

In the interest of product improvement, specifications are subject to change without notice.



## Read and Understand This Catalog

Please read and understand this catalog before purchasing the products. Please consult your OMRON representative if you have any questions or comments.

## Warranty and Limitations of Liability

### WARRANTY

OMRON's exclusive warranty is that the products are free from defects in materials and workmanship for a period of one year (or other period if specified) from date of sale by OMRON.

OMRON MAKES NO WARRANTY OR REPRESENTATION, EXPRESS OR IMPLIED, REGARDING NON-INFRINGEMENT, MERCHANTABILITY, OR FITNESS FOR PARTICULAR PURPOSE OF THE PRODUCTS. ANY BUYER OR USER ACKNOWLEDGES THAT THE BUYER OR USER ALONE HAS DETERMINED THAT THE PRODUCTS WILL SUITABLY MEET THE REQUIREMENTS OF THEIR INTENDED USE. OMRON DISCLAIMS ALL OTHER WARRANTIES, EXPRESS OR IMPLIED.

### LIMITATIONS OF LIABILITY

OMRON SHALL NOT BE RESPONSIBLE FOR SPECIAL, INDIRECT, OR CONSEQUENTIAL DAMAGES, LOSS OF PROFITS OR COMMERCIAL LOSS IN ANY WAY CONNECTED WITH THE PRODUCTS, WHETHER SUCH CLAIM IS BASED ON CONTRACT, WARRANTY, NEGLIGENCE, OR STRICT LIABILITY.

In no event shall the responsibility of OMRON for any act exceed the individual price of the product on which liability is asserted.

IN NO EVENT SHALL OMRON BE RESPONSIBLE FOR WARRANTY, REPAIR, OR OTHER CLAIMS REGARDING THE PRODUCTS UNLESS OMRON'S ANALYSIS CONFIRMS THAT THE PRODUCTS WERE PROPERLY HANDLED, STORED, INSTALLED, AND MAINTAINED AND NOT SUBJECT TO CONTAMINATION, ABUSE, MISUSE, OR INAPPROPRIATE MODIFICATION OR REPAIR.

## Application Considerations

### SUITABILITY FOR USE

OMRON shall not be responsible for conformity with any standards, codes, or regulations that apply to the combination of products in the customer's application or use of the products.

At the customer's request, OMRON will provide applicable third party certification documents identifying ratings and limitations of use that apply to the products. This information by itself is not sufficient for a complete determination of the suitability of the products in combination with the end product, machine, system, or other application or use.

The following are some examples of applications for which particular attention must be given. This is not intended to be an exhaustive list of all possible uses of the products, nor is it intended to imply that the uses listed may be suitable for the products:

- Outdoor use, uses involving potential chemical contamination or electrical interference, or conditions or uses not described in this catalog.
- Nuclear energy control systems, combustion systems, railroad systems, aviation systems, medical equipment, amusement machines, vehicles, safety equipment, and installations subject to separate industry or government regulations.
- Systems, machines, and equipment that could present a risk to life or property.

Please know and observe all prohibitions of use applicable to the products.

NEVER USE THE PRODUCTS FOR AN APPLICATION INVOLVING SERIOUS RISK TO LIFE OR PROPERTY WITHOUT ENSURING THAT THE SYSTEM AS A WHOLE HAS BEEN DESIGNED TO ADDRESS THE RISKS, AND THAT THE OMRON PRODUCTS ARE PROPERLY RATED AND INSTALLED FOR THE INTENDED USE WITHIN THE OVERALL EQUIPMENT OR SYSTEM.

### PROGRAMMABLE PRODUCTS

OMRON shall not be responsible for the user's programming of a programmable product, or any consequence thereof.

## Disclaimers

### CHANGE IN SPECIFICATIONS

Product specifications and accessories may be changed at any time based on improvements and other reasons.

It is our practice to change model numbers when published ratings or features are changed, or when significant construction changes are made. However, some specifications of the products may be changed without any notice. When in doubt, special model numbers may be assigned to fix or establish key specifications for your application on your request. Please consult with your OMRON representative at any time to confirm actual specifications of purchased products.

### DIMENSIONS AND WEIGHTS

Dimensions and weights are nominal and are not to be used for manufacturing purposes, even when tolerances are shown.

### PERFORMANCE DATA

Performance data given in this catalog is provided as a guide for the user in determining suitability and does not constitute a warranty. It may represent the result of OMRON's test conditions, and the users must correlate it to actual application requirements. Actual performance is subject to the OMRON Warranty and Limitations of Liability.

### ERRORS AND OMISSIONS

The information in this document has been carefully checked and is believed to be accurate; however, no responsibility is assumed for clerical, typographical, or proofreading errors, or omissions.

2012.12

In the interest of product improvement, specifications are subject to change without notice.

**OMRON Corporation**  
Industrial Automation Company

<http://www.ia.omron.com/>



Technical Justification:

PCO-30	
Design Adjustment: CLAR-20 / DCM-16 WML COP-030	Solids Handling Building Changes
<p><u>Owner Requested Changes:</u></p> <p>The chemical storage equipment is being upgraded to provide a more cost-effective bulk chemical delivery and an improved chemical handling system inside the Solids Handling Building.</p> <p><u>Design and Scope Changes:</u></p> <p>This clarification addresses changes to the design in the Solids Handling Building, including the replacement of the (3) storage totes in the previous design with a polymer bulk storage tank. The current specification section 434143, HDXLPE Storage Tanks, applies to the new polymer tank. The tank characteristics are as follows:</p> <ul style="list-style-type: none"> <li>Tag Number: ME-8601</li> <li>Chemical Stored: Polymer</li> <li>Capacity: 6650 gal</li> <li>Diameter: 10'-2"</li> <li>Height: 14'-3"</li> <li>Heat Tracing: No</li> <li>Insulation: No</li> </ul> <p>Fitting Materials: Bellows Transition (base drains only)/B.O.S.S./PVC/SS/EPDM</p> <p>Equipment associated with the storage tank has been added, including a progressive cavity pump for polymer recirculation (P-8603). The current specification section 432357, Progressing Cavity Pumps, applies to this new pump with the following exception: The pump shall be designed for continuous and intermittent pumping of dewatering polymer, as opposed to the pumping of sludge, as described in section 1.1.A.1.</p> <p>Modifications have been made to the floor drain system and one of the radiant heaters, to accommodate these changes. Additionally, one of the overhead doors has been removed.</p> <p>Portions of the mezzanine have been removed, including one of the staircases. Other minor modifications have been made, associated to this removal.</p> <p>Equipment has been added, and modifications have been made in the Electrical Room to accommodate these changes.</p> <p>Miscellaneous electrical changes and additions are also included.</p> <p><u>Cost Impact:</u></p> <p>MWHC recommends a contract cost increase of \$87,549.00 to be executed in a change order for changes to the Solids Handling Building.</p>	

**CITY OF BEAUMONT WWTP SALT MITIGATION UPGRADE PROJECT**

**CHANGE ORDER PROPOSAL (COP) # 030  
(By Contractor)**

<b>To (Engineer/CM):</b> MWH Constructors Attention: Charles Reynolds Phone: 702-497-8024 Email: Charles.w.reynolds@mwhconstructors.com	<b>From (Contractor):</b> W.M. Lyles Co. Attention: Adam Hickman Phone: 559-801-1874 Email: ahickman@wmlylesco.com
<b>PCO/DCM No.:</b> DCM No. 16	
<b>Subject:</b> Solids Handling Building Changes	
<b>Reference Documents:</b> Clarification no. 20	
<b>DESCRIPTION</b>	
<p>Please review the attached change order associated with changes included in clarification no. 20. This change order addresses the changes in the Solids Handling Building. These cover the removal of the Polymer Totes and Stands, associated piping modifications, hand rail and stair removal, platform modifications, removal of an overhead door and building modifications, modifications to the existing drain system, addition of a chemical tank and associated piping, addition of a progressive cavity pump. In addition electrical changes and modification associated with the above changes.</p>	
Notes/Exclusions:	
<ul style="list-style-type: none"> <li>• Chemically resistant anchors or hardware</li> </ul>	
<b>COST ESTIMATE</b>	
Total cost \$ 87,549.00 – see attached breakdown	
<b>SCHEDULE IMPACT</b>	
None	
<b>Received by MWH Constructors (Date):</b>	



**RESPONSE**

**Response By:**

**Date:**

Final Distribution: Juan C. Ahumada, W.M. Lyles Co.  
Brian Knoll, Webb Associates  
MWH Inspector

W. M. Lyles Co.  
 42142 Roick Drive  
 Temecula, CA 92590

Date: 29-Nov-19

Reference #: Clarification 20 - DCM #16

Attention: Charles W. Reynolds

JOB LOCATION: City of Beaumont WWTP Salt Mitigation Upgrade Project

DESCRIPTION: Solids Handling Building Chemical Changes

Item:	Unit	Total MH	Total MH Cost	Eq. Cost	Material	Subcont.	Total Cost
1	1 LS	-46	\$ (3,608.60)	\$ (659.63)	\$ (10,381.96)	\$ (10,590.00)	\$ (25,240.19)
2	1 LS	83	\$ 6,372.07	\$ 1,161.92	\$ 66,402.69	\$ 14,967.67	\$ 88,904.35
3	1 LS	94	\$ 7,526.48	\$ 854.86	\$ 1,593.62	\$ 2,319.00	\$ 12,293.96
4	1 LS	0	\$ -	\$ -	\$ -	\$ -	\$ -
5	1 LS	0	\$ -	\$ -	\$ -	\$ -	\$ -
6	1 LS	0	\$ -	\$ -	\$ -	\$ -	\$ -
Total Costs		131	\$ 10,289.96	\$ 1,357.15	\$ 57,614.35	\$ 6,696.67	\$ 75,958.13

262

Subtotal	\$	75,958.13
Mark-up - Labor	15%	\$ 1,543.49
Mark-up - Equipment	15%	\$ 203.57
Mark-up - Materials	15%	\$ 8,642.15
Mark-up - Subcontractor	5%	\$ 334.83
Bond	1.0%	\$ 866.82
<b>Total This Change Order</b>	<b>\$</b>	<b>87,549.00</b>

Comments:









3000 YOUNGFIELD ST. SUITE 275 WHEAT RIDGE, CO 80215  
Ph. (720)508-3819 FAX (720)409-3843

## **CHANGE ORDER NO.3**

PTP #918-248-3

**Location: WWTP Salt Mitigation Upgrades – Beaumont, CA**

**To: W.M Lyles Co.**

**Date: 10/31/2019**

**Attn: Adam Hickman**

**Request for Change Order, Your Purchase Order No. 55.1173-4022**

**Please adjust the above referenced Purchase Order to reflect the following changes:  
Delete the south stair in the Solids Handling Bldg per Clarification 20. Note: C/O No.1 & No.2 are still out for approval. C/O No.3 will be based as if C/O No.1 & No.2 are approved.**

### **C.O. No.1 10-02-19 Pending**

**Credit for removing 315 LF of toe board at the Aeration Basins.**

**Original Contract: = \$97,371.00**

**Credit = <\$720.00> Note: Received verbal approval from Oscar Mendoza 10-30-19**

**Revised contract: = \$96,651.00**

### **C.O. No.2 10-18-19 Pending**

**Add rail at the retaining wall. No toe Board required.**

**Contract: 2,621 L.F. = \$97,371.00**

**Add rail: + 126 L.F. = \$4,900.00**

**2,747L.F. = \$102,271.00**

**= \$720.00 C.O. #1 Credit Pending**

**Revise Contract = \$101,551.00**

### **C.O. No.3 10-30-19 Pending**

**Delete stair per Clarification 20 at the Solids Handling Building**

**Contract: 2,747L.F. = \$102,271.00 Pending with C.O. #2**

**Delete Rail: -40 L.F. = <\$1,489.00>**

**Revised: 2,707L.F. = \$100,782.00**

**= \$720.00 C.O. #1 Credit Pending**

**Revised Contract = \$100,062.00**

**Peak to Peak Engineered Railings**

**Ray Muniz**

**[RMuniz@peaktopeakrailings.com](mailto:RMuniz@peaktopeakrailings.com)**

**(720)508-3819 Ext: 104**

**Accepted \_\_\_\_\_**

**Date \_\_\_\_\_**



**GMAT Inc dba Inland Overhead Door Company**  
**12401 S La Cadena Dr Colton CA 92324**  
**909-783-3131 fax 909-783-3478**

**Subcontractor Change Order**

Project:	CITY OF BEAUMONT-WASTEWATER TREATMENT
Contract:	PLANT SALT MITIGATION UPGRADE PROJECT 715 W 4TH ST BEAUMONT CA 92223
Date:	10/22/2019

**Subcontractor:** GMAT Inc. dba Inland Overhead Door Company

**Contract for:** W.M. Lyles Company Contractor  
P.O. Box 4377 Fresno CA 93744  
55.1173.010

DELETE ONE (1) 12x12 COILING DOOR AT SOILDS HANDLING BUILDING

Contract Amount		<u>\$33,500.00</u>
CHANGE ORDER 1		4,800.00
Change Order 2		<u>-5,100.00</u>
Sub Total		<u>33,200.00</u>
Total Contract Amount		<u>\$33,200.00</u>

Subcontractor Sign-Date

Contractor Sign-Date

 Ryan Sherrill

\_\_\_\_\_

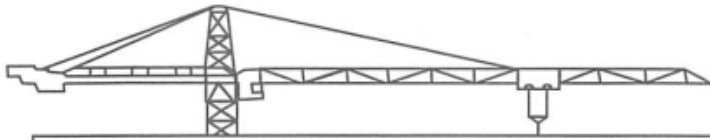

# ALLIED STEEL CO., INC.

*Structural Steel & Miscellaneous Metal Fabricators*



October 31, 2019

W.M. Lyles Co.  
42142 Roick Dr.  
Temecula, CA 92590

Attn: Mr. Adam Hickman

Re: City of Beaumont WWTP

Subject: Solids Handling Building Changes  
Clarification 20

This change eliminated one stair and supporting columns along with a portion of the platform on the Solids Handling Building for the above referenced project. The following is a cost breakdown for this change. Please note that the shop drawings is an increased cost but all else is a cost decrease.

Material credit (includes tax)	<\$ 1,330.00>
Shop labor credit (22) MH x \$ 85.00 =	<\$ 1,870.00>
Grating credit (includes tax)	<\$ 2,930.00>
Detailing costs (8) MH x \$ 80.00 =	\$ 640.00
<b>TOTAL CREDIT</b>	<b>&lt;\$ 5,490.00&gt;</b>

Please issue Allied Steel a change order for <\$ 5,490.00> to eliminate this work from our subcontract.

Sincerely,

Brian P. Chapman  
President







FERGUSON WATERWORKS #1083  
 11909 TECH CENTER COURT  
 POWAY, CA 92064-7139

Phone: 858-391-3700  
 Fax: 858-391-5958

Deliver To:  
 From: Nick Grantham  
 Comments:

13.

11:31:29 OCT 28 2019

Page 1 of 1

FERGUSON WATERWORKS #1083

Price Quotation  
 Phone: 858-391-3700  
 Fax: 858-391-5958

**Bid No:** B353916  
**Bid Date:** 10/28/19  
**Quoted By:** XNG

**Cust Phone:** 559-487-7926  
**Terms:** NET 10TH PROX

**Customer:** WM LYLES CO  
 551173-BEAUMONT WW TRTMT  
 PO BOX 4377  
 FRESNO, CA 93744

**Ship To:** WM LYLES CO  
 551173-BEAUMONT WW TRTMT  
 PO BOX 4377  
 FRESNO, CA 93744

**Cust PO#:** TRENCH DRAIN QUOTE

**Job Name:** 55.1173-BEAUMONT WW TRTMT

Item	Description	Quantity	Net Price	UM	Total
NDS091	6X48 D/SLOPE CHAN # 091	2	119.570	EA	239.14
NDS092	6X48 D/SLOPE CHAN # 092	2	119.570	EA	239.14
NDS224	D/SLOPE DRN END CAP	2	15.015	EA	30.03
NDS126	BOT OUT ADPT D/SLOPE	1	34.160	EA	34.16
NDS200H	24X6 DI DURA SLOPE GRATE FRM	6	41.328	EA	247.97
NDS232	2 SLOT DI GRATE	6	55.270	EA	331.62
NDS123	END CAP & DI FRM GRATE SCRW 12 PK	3	5.370	PK	16.11
MUL043235	4 PVC SWR GXG 90 ELL	2	12.740	EA	25.48
MUL063307	6X4 PVC SWR GXG WYE	1	28.330	EA	28.33
MUL063304	4 PVC SWR GXG WYE	1	13.970	EA	13.97

**Net Total:** \$1205.95  
**Tax:** \$118.77  
**Freight:** \$283.49  
**Total:** \$1608.21

Quoted prices are based upon receipt of the total quantity for immediate shipment (48 hours). SHIPMENTS BEYOND 48 HOURS SHALL BE AT THE PRICE IN EFFECT AT TIME OF SHIPMENT UNLESS NOTED OTHERWISE. QUOTES FOR PRODUCTS SHIPPED FOR RESALE ARE NOT FIRM UNLESS NOTED OTHERWISE.

CONTACT YOUR SALES REPRESENTATIVE IMMEDIATELY FOR ASSISTANCE WITH DBE/MBE/WBE/SMALL BUSINESS REQUIREMENTS.

Seller not responsible for delays, lack of product or increase of pricing due to causes beyond our control, and/or based upon Local, State and Federal laws governing type of products that can be sold or put into commerce. This Quote is offered contingent upon the Buyer's acceptance of Seller's terms and conditions, which are incorporated by reference and found either following this document, or on the web at <https://www.ferguson.com/content/website-info/terms-of-sale>  
 Govt Buyers: All items are open market unless noted otherwise.

LEAD LAW WARNING: It is illegal to install products that are not "lead free" in accordance with US Federal or other applicable law in potable water systems anticipated for human consumption. Products with \*NP in the description are NOT lead free and can only be installed in non-potable applications. Buyer is solely responsible for product selection.  
 WATER FLOW RATE NOTICE: Lavatory Faucets with flow rates over 0.5 GPM are not allowed for 'public use' in California.



HOW ARE WE DOING? WE WANT YOUR FEEDBACK!

Scan the  or use the link below to complete a survey about your bids:

<https://survey.medallia.com/?bidsorder&fc=1083&on=25463>



**QUOTATION**

13.

**Billing Inquiries:** (951) 340-4444

Sell To:  
 W M Lyles Company J  
 P O Box 4377  
 Attn: Karen Higham  
 Fresno, CA 93744

**Page:** 1 of 1  
**Bid Number:** 6686160  
**Quote Date:** 10/30/2019  
**Entered By:** Darryl McCormick - 001  
**Description:** DEM-BEAUMONT CLARIFICATION

Ship To:  
 W M Lyles Company J  
 14903 River Road  
 Corona, CA 92880

**Account Number:** 079562  
**Contact Name:**  
**Contact Phone:** (951) 973-7393

Note: The following does not include Shipping & Handling, Tax, or other applicable charges.

Product #	Description/Notes	Uom	Qty	Price	Total
3806G025	PVC 90 EL N80 2.5" S SLOANE	EA	4	4.8006	19.20
3817G025	PVC 45 EL N80 2.5" S SLOANE	EA	2	10.1682	20.34
5090A025	PVC/EPDM TU B VLV 2.5" S ASAHI TYPE-21 230PSI	EA	2	158.3680	316.74
5109S025	PVC/EPDM TU B CK VLV 2.5" S	EA	1	208.6070	208.61
3855G025	PVC VAN STONE FLG N80 2.5"S	EA	3	8.1000	24.30
3836G025	PVC MALE ADPT N80 2.5"	EA	1	6.4125	6.41
3905H025	PVC HIGH-QUALITY PIPE N80 2.5"	EA	60	2.5326	151.96
3806G020	PVC 90 EL N80 2" S SLOANE	EA	10	2.0520	20.52
3801G020	PVC TEE N80 2" S SLOANE	EA	1	7.3062	7.31
5090A020	PVC/EPDM TU B VLV 2" SXT ASAHI TYPE-21 230PSI	EA	1	71.7605	71.76
3905H020	PVC HIGH-QUALITY PIPE N80 2"	EA	60	1.5410	92.46
3855G020	PVC VAN STONE FLG N80 2" S	EA	2	5.2461	10.49
5351.020	PVC LINE STRAINER 2" S YS10200S	EA	1	159.9156	159.92
5109S020	PVC/EPDM TU B CK VLV 2" SXT	EA	1	181.9216	181.92
1304.020	Q-D MALE CPLR 2"MT PP BLK	EA	1	12.8700	12.87
3835G020	PVC FEM ADPT N80 2" SXT SLOANE	EA	1	7.3926	7.39
0512.150	HERCO BRAID TUBING 2" FD GRD HD HEAVY-DUTY K3156-H32 X 50	EA	10	4.9200	49.20
3860.307	316SS BOLT PACK FOR 2" FLG BOLTS = 5/8" X 3"LONG	EA	1	12.9640	12.96
3863.020	EPDM AV GSK 2"	EA	1	6.7865	6.79
3860.308	316SS FLG BOLT PACK 2.5" - 3" BOLTS = 5/8" X 3.25"	EA	1	14.6685	14.67
3863.025	EPDM AV GSK 2.5"	EA	1	6.7865	6.79
UNISTRUT/CLAMPS					
1950A653	1-5/8" UNISTRUT SLOTTED 304SS	EA	20	9.2000	184.00
1987A103	SS UNISTRUT CLAMP 2" (2-3/8" OD)	EA	8	5.8200	46.56
/GFN02588205	SS UNISTRUT CLAMP 2-1/2"2-5/8 OD	EA	7	6.9245	48.47
/GFN02588206	SS POST BASE	EA	7	68.2000	477.40
	---- Package Subtotal:		2,159.04		

**Subtotal:** 2,159.04

**QUOTATION**

13.



**Billing Inquiries:** (951) 340-4444

Sell To:  
 W M Lyles Company J  
 P O Box 4377  
 Attn: Karen Higham  
 Fresno, CA 93744

**Page:** 1 of 1  
**Bid Number:** 6695383  
**Quote Date:** 11/25/2019  
**Entered By:** Jasmine Penaloza - 045  
**Description:** JP3 | PLASTIC | AHICKMAN

**Account Number:** 079562  
**Contact Name:** ADAM HICKMAN  
**Contact Phone:** (951) 973-7393

Ship To:  
 W M Lyles Company J  
 14903 River Road  
 Corona, CA 92880

Note: The following does not include Shipping & Handling, Tax, or other applicable charges.

Product #	Description/Notes	Uom	Qty	Price	Total
3855S030	PVC VAN STONE FLG N80 3" S SPEAR	EA	2	9.2008	18.40
3905H030	PVC HIGH-QUALITY PIPE N80 3"	EA	20	2.7900	55.80
5351.020	PVC LINE STRAINER 2" S YS10200S	EA	1	140.8212	140.82
5060H020	+PHO+ PVC/EPDM TU B VLV 2" SXT +++++++ PHASING OUT ++++++	EA	2	75.5405	151.08
5060H025	PVC/EPDM TU B VLV 2.5" S HAYWARD	EA	1	167.5240	167.52
5060H030	PVC/EPDM TU B VLV 3" S HAYWARD	EA	1	173.4145	173.41
5102H020	PVC/VIT TU B CK VLV 2" SXT	EA	1	105.8155	105.82
5102H025	PVC/VIT TU B CK VLV 2.5" S	EA	1	240.5095	240.51
	---- Package Subtotal: 1,053.36				

**Subtotal:** 1,053.36

272

<b>To:</b> W.M. Lyles Temecula, CA  <b>Attn:</b>  <b>Subject:</b> 55.1173-4024 - Beaumont Clarification 20	<b>Offer</b>	JB-B000374484
	<b>Date</b>	11/22/2019
	<b>Your contacts:</b>	
	Internal sales	Joseph Benjamin
	Phone:	(610) 280-1281
	Fax:	(610) 363-0971
	Email:	<a href="mailto:Joseph.Benjamin@NETZSCH.com">Joseph.Benjamin@NETZSCH.com</a>
	External sales	Andreas Schmidt
	Phone:	(484) 502-8115
Email:	<a href="mailto:Andreas.Schmidt@NETZSCH.com">Andreas.Schmidt@NETZSCH.com</a>	

### Pump Quotation - Commercial

Thank you for your inquiry, we are pleased to offer suitable pumps with our payment and delivery terms:

Pos.	Description	Quantity	Unit price (net in USD)	Total price (net in USD)
0010	NETZSCH NEMO Progressive Cavity Pump model NM031BY01L06B with a 3 hp motor and reducer mounted inline on a Carbon Steel - 1020 baseplate as per the technical.	1	\$5,267	\$5,267
0020	**Shipping and Insurance to California			\$321

Delivery Time <sup>3</sup> :	6-8 weeks	Payment Terms:	Net 30	Total Offer:	\$5,588
------------------------------	-----------	----------------	--------	--------------	---------

#### Optional Price Adders:

	Unit price (List in USD)	Unit price (net in USD)
Protection against dry running by installing a thermal protection device to monitor the operating temperature of the stator. (Probe shipped mounted in stator and controller shipped loose)	\$1,170	\$819

2. When corresponding, please refer to the offer number.

3. For details see Delivery on Page 2 for details

# NETZSCH Pumps North America, LLC.



<b>Offer</b>	JB-B000374484
<b>Date</b>	11/22/2019

### Delivery shipping and payment conditions:

#### Delivery:

The listed lead time is based on the specific design requirements, current inventory, or standard manufacturing lead times. All pumps are subject to prior sale. Please consult factory at the time of order to obtain a lead time.

#### Shipping:

**Total Gross Weight (lbs.) for all pumps offered:** 150 lbs.

**Shipping Terms:** EXW Exton, PA

**Est. transit time:** 7 working days

*\*\*Note: If customer schedules and arranges his own Shipping, shipping details to be provided at time of order.*

**Offer validity:** December 22, 2019

**Payment conditions:** Net 30

#### Warranty and Terms of Sale:

For a period of 12 months from the date of shipment, or transfer of ownership, NETZSCH Pumps North America, LLC provides a warranty against defective materials or improper workmanship. This quotation is limited to NETZSCH Pumps North America, LLC terms and condition of sale. No other terms and conditions will be accepted.

For information concerning our Terms and Conditions of Sale, and complete warranty information for NETZSCH Equipment and Accessory Items (Motors, Reducers, etc.) please review our current Terms and Conditions of Sale by clicking this link.



We trust our offer is of interest and look forward to discussing this with you in the near future.

Yours sincerely,

**Joseph Benjamin**

Sales Application Engineer

#### NETZSCH Pumps North America, LLC

Phone: 001 (610) 363-8010  
 Direct dial: 001 (610) 280-1281  
 Fax: 001 (610) 363-0971  
 E-Mail: [Joseph.Benjamin@NETZSCH.com](mailto:Joseph.Benjamin@NETZSCH.com)  
 Website: <http://www.pumps.NETZSCH.com>

NETZSCH Pumps North America, LLC.  
119 Pickering Way  
Exton, PA 19341

Trademarks by NETZSCH Pumps North America, LLC:  
M.Champ, TORNADO, TORNADO (Picture), N-IPO S, N-ELOR, abP-Module,  
pmT Pilot, NEMO, iFD Stator, NEMOLAST, T.AGRI, T.ENVI, T.PROC, T.RURA, T.SANO  
C.Pro, NE, NEMO CERATEC, M-Ovas, Blue-grey design, uNS-Seal.

Tel: +1 610-363-8010  
Fax: +1 610-363-0971  
Email: [npa@NETZSCH.com](mailto:npa@NETZSCH.com)  
Website: [www.pumps.NETZSCH.com](http://www.pumps.NETZSCH.com)



Adam Hickman  
 W.M. Lyles Company  
 42142 Roick Drive  
 Temecula, CA 92590  
 951-973-7393 ext  
[ahickman@wmlylesco.com](mailto:ahickman@wmlylesco.com)

Quote Number: DSN1216Q  
 Tank: 6650 Gallon Double Wall Safe Tank  
 Specification: 434143

Dear Adam,

Thank you for the opportunity to provide the following quote. The tank and all of the accessories are per the specification noted. We also included pricing for the radar level control units.

**BEAUMONT WWTP SALT MITIGATION UPGRADE- Tank/ Radar**

Spec Section	Title and Description
<b>434143</b>	<p><b>HIGH DENSITY CROSS-LINKED POLYETHYLENE STORAGE TANK</b></p> <ul style="list-style-type: none"> <li><b>(1) 6,650 Gallon Poly Processing Double Wall Safe Tank</b></li> <li>Safe Surge Manway</li> <li>FRP Ladder</li> <li>SST Seismic Restraints with CA Wet Stamped Job Specific Calculations</li> <li>Float Level Indication</li> <li>Fittings per specification</li> <li>PTFE Flexi Joints</li> <li>Material and Tank Testing</li> <li>3.2 B, C,D,E Field Service Technician one person one day included</li> <li>10' Dia. X 14'-4" Tall</li> </ul> <p><b>No Exceptions taken to specification 434143</b></p>
<b>Radar Level</b>	<p><b>Flowline</b>            Echo Pulse LR20 Radar Liquid Level Transmitter with 316L Antenna and PTFE inner shield-  <b>No Exceptions to the spec</b></p>
Spec Section	Comment
3.2 A and 3.3	Field Testing and Installation by Others (1 day site inspection/ training is included)
General	Anchor bolts by others
General	Piping beyond vessel connections is not included
Standard Terms	25% with order / balance 70% N20 after shipment / 5% retention 90 days
Sales Tax	Sales tax will be billed at the rate in effect at the time of shipment and not included above
Disclosure	Items not specifically identified within proposal are not included

**Tank Pricing**

6650 Double Wall Safe Tank and all accessories noted in specification \$46,440.  
 Freight for tank \$3,100.  
 Radar \$2,590.  
 Freight for Radar ...\$40.

**Terms and Conditions**

Shipment	4-5 weeks- Tanks and Radar
Manufacturer's Warranty	Tanks: 3 years and 5 years per specification Radar: 1 year
FOB Point	Tank: Poly Processing Factory Radar: Flowline Factory
Prices Effective	30 days
Freight	Quoted as an option
Sales Tax	Not included unless otherwise indicated
Sales Tax	Will be charged unless a resale card is on file (CA)
Freight Billing	To be by purchaser specified at time of order placement
Terms	25% with order, balance net 20 days after shipment - OAC
Cancellation Charges	100% after fabrication commences
Damaged Freight	Must be noted on the freight bill to establish liability
Off-Loading / Installation	By others
Anchor Bolts	Not included unless otherwise indicated
Flange Gaskets / Bolt Kits	Not included unless otherwise indicated
Flexible Connections	Required for most connections to preserve tank warranty
Missing Parts	Claims must be made within 30 days of delivery

Thank you,

*Doug Roughen*

Doug Roughen | 3300 E. 19th Street | Signal Hill, CA 90755 | 562-986-5238 FAX 562-986-5246  
**Cell 949-633-9499 Preferred**





**G&W BUILDER** 13. **C.**  
 General Contractor  
 And Engineers  
 Lic. No. 457076 A & B

557 MERCURY LANE • BREA, CA 92821 • (714) 529-9935 • FAX (714) 529-0795

# REQUEST FOR CHANGE ORDER

**DATE:** October 29, 2019

**TO:** W.M Lyles CO      **PROJECT:** Wastewater Treatment Plant Salt Mitigation Upgrade Project  
**ATTENTION:** Mr. Adam Hickman      **REQUEST:** #02  
**ADDITIONAL INFORMATION ATTACHED:** No **PAGES:** 1 (INCLUDING THIS PAGE) **CONTRACT #:** 55.1173.002

	DESCRIPTION: Changes made to Solids Handling Building	AMOUNT
1.	Remove 12' x 12' Framed Opening and infill with IMP wall panel.	
2.	Relocate radiant heater to center bay.	
3.	Additional Labor to install girts and panels.	
<b>TOTAL ADD</b>		<b>\$2,000.00</b>

**REASON FOR CHANGES:**  
 1. Client has requested we infill the roll up door and move the radiant heater over a bay.  
  
 Previous Contract Total: \$1,624,523.00  
 New Contract Total: \$1,626,523.00

Requested by: Bill M. Greer 9/4/19  
 Sign and Date

Accepted by: \_\_\_\_\_  
 Sign and Date



Southern Contracting Company  
P.O. Box 445 San Marcos, CA 92079-0445  
Tel 760-744-0760 Fax 760-744-6475  
website: www.southerncontracting.com  
email: info@southerncontracting.com

## Change Order Request

**103801 — Wastewater Treatment Plant Salt Mitigation Upgrade**

**COR Subject: Solids Handling Chnages**

**To** Juan C. Ahumada  
W.M. Lyles  
42142 Roick Drive  
Temecula, CA 92590  
951-973-7393

**Contract No: 55.1173**  
**COR Number: 103801-COR#015**  
**COR Revision Number: 0**

**COR Date: 11/6/2019**  
**Work Type: Price / Do Not Proceed**

**Return To** Dan Alcantar  
Southern Contracting Company  
760-744-0760x621  
619-778-0681  
DAlcantar@southerncontracting.com

**Other Reference No: DCM#016**  
**CLAR#020**  
**Days Valid: 5**

### Scope Of Work / Time Extension Request

The work associated with DCM16 CLAR 20 is a change to Southern Contracting Company's scope of work in which a change in Contract Price and Time is to be considered. Accordingly, Southern Contracting Company requests a Contract Change Order in the amount of \$11,467.67

Scope of Work is as follows:

- Provide labor and materials to install conduit and wire to the new Polymer Tank ME-8601 for the Motor and Level Element. Install LCP-8603.
- This work includes changes to MCC-SH, Level Element LIT-8601. Documentation and drawing updates.

Exclusions:

- Digging, backfill, concrete formed or poured, dry packing, surface restoration, permits, inspections.

Change in time: NA

Southern Contracting reserves all rights to additional costs and time for changes not identified in the documents furnished, and is not responsible for additional costs or time for work which is not part of our contract scope of work, unless stipulated above. Should additional information or clarification be required, please contact me at your convenience.

### Summary

**Total: \$11,467.67**

**Reservation of Rights**

This COR does not include any amount for impacts such as interference, disruptions, rescheduling, changes in the sequence of work, delays and/or associated acceleration. We expressly reserve the right to submit our request for any of these items.

Signed By:



Daniel Alcantar  
PM

Dated: 11/6/2019

# Bid Summary Report

13.

103801 Beaumont Chang Orders Estimator: Dan Alcantar

Job #2336

**Job Name:** 103801 Beaumont Chang Orders

**Contractor:**

**Estimator:** Dan Alcantar

**Notes:**

**Bid Date:**

Summary Description	Material			Labor		
	Extended	%	Adjusted	Extended	%	Adjusted
COE#015 DCM-016 CLAR-020 Solids Handling Changes	\$1,574.72	100.00%	\$1,574.72	58.32	100.00%	58.32

## Top Sheet

Raw Cost	\$9,767.03	Sales per Month	\$0.00
Tax	\$122.04	Return per Month	\$0.00
Raw Cost with Tax	\$9,889.07	Price per Square Foot	\$0.00
Overhead	\$1,465.05	Hours per Square Foot	0.00
Profit	\$0.00	Square Feet	0.00
Total Return Amount	\$1,465.05	Job Months	0.00
Total Return %	12.78%	Hours per Week	0.00
Price	\$11,354.13	Workers per Day	0.00
Bond	\$113.54	Total Hours	58.32
Sell Price	<b>\$11,467.67</b>	Mark Up Sales Tax	Yes
Adjusted Sell ()	\$0.00	Use Bond Table	Yes
Adjusted Sell Return 0.00 %	\$0.00		

## Labor

Class Description	Percent of Total	Hours Distributed	Hourly Rate	Burden		Labor Cost
				Rate	Percent	
General Foreman	10.00%	5.83	\$89.17	\$0.00	0.00%	\$520.00
Journeyman	50.00%	29.16	\$75.48	\$0.00	0.00%	\$2,200.84
Appr-85%	50.00%	29.16	\$63.90	\$0.00	0.00%	\$1,863.19
<b>Totals</b>	<b>110.00%</b>	<b>64.15</b>	<b>\$71.46</b>	<b>\$0.00</b>	<b>0.00%</b>	<b>\$4,584.03</b>

## Mark Ups

	OVERHEAD			PROFIT		
	Total	%	Amount	%	Amount	
Materials	\$1,574.72	+ 15.00%	\$1,810.93	+ 0.00%	\$1,810.93	
Labor	\$4,584.03	+ 15.00%	\$5,271.64	+ 0.00%	\$5,271.64	

## Bid Summary Report

13.

**103801 Beaumont Chang Orders**     Estimator: Dan Alcantar

**Job #2336**

Supplier Quotes	\$3,068.01	+	15.00%	\$3,528.21	+	0.00%	\$3,528.21
SubContractors	\$0.00	+	5.00%	\$0.00	+	0.00%	\$0.00
Direct Job Expense	\$540.27	+	15.00%	\$621.31	+	0.00%	\$621.31
Equipment Rental	\$0.00	+	15.00%	\$0.00	+	0.00%	\$0.00
<b>Totals</b>	<b>\$9,767.03</b>		<b>15.00%</b>	<b>\$11,232.09</b>		<b>0.00%</b>	<b>\$11,232.09</b>

### Tax Report

	Taxed Amount	Tax Rate %	Tax Amount
Materials	\$1,574.72	7.75%	\$122.04
Labor	\$4,584.03	0.00%	\$0.00
Supplier Quotes	\$0.00	0.00%	\$0.00
SubContractors	\$0.00	0.00%	\$0.00
Direct Job Expense	\$0.00	0.00%	\$0.00
Equipment Rental	\$0.00	0.00%	\$0.00
<b>Total Tax:</b>			<b>\$122.04</b>

### Supplier Quotes

Name	Supplier	Tax (0.0 %)	Unit Cost	Multiplier	Amount
Intrumentation and controls		No	\$3,068.00	1.00	\$3,068.00
Mods to MCC-SH EATON -No Cost		No	\$0.01	1.00	\$0.01
<b>Total:</b>					<b>\$3,068.01</b>

### Direct Job Expense

Name	Supplier	Tax (0.0 %)	Unit Cost	Multiplier	Amount
FM Truck		No	\$18.63	29.00	\$540.27
<b>Total:</b>					<b>\$540.27</b>

Job Name: 103801 Beaumont Chang Orders

Job Number: 2336

Extension Name: COE#015 DCM-016 CLAR-020 Solids Handling Changes

[Items and ByProducts]

Material Filter: <None>  
Report: COR - 2

Item #	Item Name	Quantity	Ext Price	Ext Labor
Label Set: Combined, Combined, Combined, Combined, Combin				
Cost Code: 010 - Conduit/Raceway				
2,600	1/2" SS WEDGE ANCHOR	4.00	\$46.00	1.00
2,614	1/4x1" SS SCREWS	12.00	\$4.08	2.11
2,624	1/4" SS WASHER	24.00	\$2.64	0.00
2,631	1/4" SS NUT	12.00	\$1.61	0.00
2,658	1 5/8 STRUT-STAINLESS	6.00	\$71.25	1.13
2,685	1 GRC/PVC COATED	40.00	\$225.25	5.02
2,712	1 GRC/PVC ELBOW	4.00	\$73.97	3.27
2,750	1X8 GRC/PVC NIP	4.00	\$31.13	1.76
2,765	1 GRC/PVC HUB	4.00	\$174.09	2.51
2,920	1 GRC/PVC 1H STRAP	2.00	\$13.41	0.10
2,972	1 GRC/PVC CLAMP BAK	2.00	\$25.64	0.15
2,940	Stanchion Installation	1.00	\$311.18	1.50
Cost Code: 020 - Wire/Cable				
4	16 TSP - SHIELDED CABLE BELDEN	250.00	\$180.00	3.14
44	12 THHN CU STRANDED	1,500.00	\$195.27	11.30
60,050	Wire Tags Tube Style	12.00	\$30.00	0.12
Cost Code: 110 - Underground				
3,188	1 PVC 40 (TRENCH)	200.00	\$91.61	10.05
3,217	1 PVC ELBOW	4.00	\$16.70	1.76
3,461	1 PVC FEMALE ADPT	2.00	\$1.10	0.45
Cost Code: 140-Instrumentation				
10,162	1PB STATION OIL-TIGHT	1.00	\$79.80	12.94
10,194	3POS SWING KNOB SWITCH	1.00	\$79.80	1.63
15,819	LE/LIT -LEVEL, FBO	1.00	\$0.00	1.88
15,840	SM PANEL -FBE	1.00	\$0.00	4.40
<b>[Items and ByProducts] Total:</b>				<b>5.02</b>
				<b>58.32</b>

282

**Scope Letter: 2 pages**

Technical  
Systems  
Incorporated

2303 196th Street SW  
Lynnwood, WA 98036  
Tel: (425) 775-5696  
Fax: (425) 775-9074  
info@tsicontrols.com

October 10, 2019

Quote Number: CO#04

To: Southern Contracting  
Attn: Dan Alcantar

Project: Beaumont WWTP Salt Mitigation  
Beaumont Wastewater Treatment Plant

Reference: **CLAR-20 Solids Handling Building Changes**

Bid Date: N/A

Bid Time: N/A

Technical Systems, Inc. (TSI) is pleased to provide a quote for the above referenced project. Material for this project will be shipped FOB Lynnwood WA, complete, ready for field termination by others. TSI's price includes CA sales tax and does not include the cost to bond TSI's portion of the project.

TSI's price for the scope of work detailed on the following pages:

**Change Order Proposal Pricing:**

**\$3,068.00**

**Change Scope as Follows:**

- Supply Display Unit LI-8601
  - o Precision Digital PD6700 Loop-Powered Display
  - o NEMA 4X, Grey Plastic Field Enclosure, 0.5W Power draw at 24vdc
  - o Note: LIT-8601 excluded as it is provided by tank vendor
- Supply LCP-P-8603
  - o H-O-R Switch
  - o 304SS Enclosure 6"x6"x4"
- Modify LCP-SHDC as indicated on E-25
  - o Show Lid Switches on drawings – no physical mods required
- Incorporated added I/O into RIO-SH per I-18

Terms: Net 30  
FOB: Lynnwood WA  
Freight: Prepaid

This quote is valid for 90 days.

Please call with any questions you may have concerning pricing or any technical questions.

Sincerely,

*Colin Dightman-Kovak*

Colin Dightman-Kovak  
 Technical Systems, Inc.  
 1-425-678-4116

### **Scope of Work**

#### **Misc Equipment:**

Including:

1. Hardware Procurement
2. Required Testing
3. O&M, drawings updates

### **GENERAL**

1. TSI supplies a bill of materials, CAD-based drawings, and Operations and Maintenance Manuals for all equipment furnished by TSI.
2. TSI supplies the required field startup services for this project.
3. Panels fabricated by TSI are UL 508 labeled.

### **STANDARD INCLUSIONS**

We provide the following unless specifically excluded on our bill of material:

- 1) Equipment shipped FOB factory with freight allowed, tailgate, destination.
- 2) Field wiring diagrams showing interconnection of field instruments and instrumentation panels.
- 3) Instruction manuals as required.
- 4) All necessary field start-up and calibration of the equipment we supply.

### **STANDARD EXCLUSIONS**

We do NOT include the following unless specifically included in our bill of material:

- 1) Pipe, tubing, valves or fittings between the instrument and the process.
- 2) Conduit, wire or cable not an integral part of the instrument.
- 3) Mounting brackets, stanchions, supports or mounting pads not an integral part of the instrument.
- 4) Labor to install the equipment.
- 5) The Cost, (if due to local union regulations), to have local craftsman make adjustments or wiring modifications to our equipment during start-up and calibration.
- 6) Any material or services not in our quoted sections.
- 7) This proposal is based on award of a supply purchase order and does not include any of the costs associated with bonding or subcontract administration. If bonding or a subcontract is required they can be provided for additional cost.



**SPECIFIC EXCLUSIONS**

- 1) Installation of Panels.
- 2) LIT-8601 is provided by others
- 3) FVNR-P-8603 is provided by others as part of MCC-SH



**Contractor:** WM Lyles

**Date:** 10/30/2019

**Job Name:** Salt Mitigation WWTP Upgrades

**PSG Job #:** L18161

**Extra No.:** 13

**Description:** Added Material and Labor for new Tank Pad per Clarification 20.

Please see attached correspondence.

Material:	Quantity:	Unit:	Unit Price:	Comments:	Extended Price:
Rebar	1,200	LB	\$ 0.60		\$ 720.00
Specialty Rebar	-	LB	\$ 1.50		\$ -
Mesh	-	SQFT	\$ 0.35		\$ -
Couplers	-	Each	\$ 1.75		\$ -
Other	-	Each	\$ -		\$ -
					\$ 720.00

Labor Impact:	Quantity:	Unit:	Unit Price:	Comments:	Extended Price:
Rebar	12	Hours	\$ 94.04		\$ 1,128.00
Specialty Rebar	-	Hours	\$ 94.04		\$ -
Mesh	-	Hours	\$ 94.04		\$ -
Couplers	-	Hours	\$ 94.04		\$ -
Other	-	Hours	\$ 94.04		\$ -
					\$ 1,128.00

FWA Labor:	Quantity:	Unit:	Unit Price:	Comments:	Extended Price:
Ironworker	-	Hours	\$ 94.04	Regular Base Pay	\$ -
Overtime	-	Hours	\$ 53.90	Premium Portion Only	\$ -
Doubletime	-	Hours	\$ 83.80	Premium Portion Only	\$ -
					\$ -

Other:	Quantity:	Unit:	Unit Price:	Comments:	Extended Price:
Engineering	2.00	Hours	\$ 70.00	Additional Detailing	\$ 140.00
Crane	-	Hours	\$ 300.00		\$ -
Delivery	-	Each	\$ 550.00		\$ -
Other	-	Each	\$ -		\$ -
					\$ 140.00

Sub Total = \$ 1,988.00

Overhead & Profit @ 10% & 5% = \$ 308.00

Sub Total = \$ 2,296.00

Bond Fee = \$ 23.00

Total Extra To Contract = **\$ 2,319.00**

**Item Attachment Documents:****14. City Council Approval of Change Order No. 13 for the Wastewater Treatment Plant Upgrade/Expansion in the Amount Not to Exceed \$404,821.33**

## Recommended Action:

Approval of Change Order No. 13 for the Wastewater Treatment Plant Upgrade/Expansion in the amount not to exceed \$404,821.33.



## Staff Report

**TO:** Mayor, and City Council Members  
**FROM:** Kristine Day, Assistant City Manager  
**DATE:** January 07, 2020  
**SUBJECT:** City Council Approval of Change Order No. 13 for the Wastewater Treatment Plant Upgrade/Expansion in the Amount Not to Exceed \$404,821.33

### Background and Analysis:

On May 7, 2019, staff and the design engineer presented multiple owner initiated change order concepts for the City Council to consider that will provide for better overall operation and efficiency of the new plant.

### Wastewater Treatment Plant Change Order No. 13:

#### Item #1 - Plant Effluent Chemical Area Changes:

One change which was previously presented to the City Council was to add pH adjustment to be able to optimize the RO system performance. Although historical pH at the wastewater treatment plant (WWTP) had been within the desired operating parameters of the RO system, the new plant staff's experience with RO systems requires the ability to have pH flexibility. In addition, the City has implemented a pre-treatment program and the program is changing the pH of the background water coming in to the treatment plant. Therefore, as part of a previously approved MBR chemical storage change order, the City approved the addition of acid storage and dosing in order to lower pH. The City must then adjust pH back up in order to meet discharge requirements. This change order includes facilities to provide bulk storage and dosing for sodium hydroxide for pH adjustment.

Based upon the experience of operation staff, there is a potential for chlorine (used to clean the RO membranes) to come through the RO system and therefore there is a need to have sodium bisulfite to neutralize the chlorine prior to being discharged to Cooper's Creek. This requirement will be part of the plant's new discharge permit. Therefore, bulk storage and chemical dosing pumps are being proposed at the plant effluent.

Each of these areas have concrete chemical containment areas, chemical piping, dosing pumps, analyzers, potable water, chemical mixing system, electrical, lighting, and eyewash showers included.

After further discussion with the Beaumont Cherry Valley Water District, it was decided that any chemical conditioning required for reuse discharge would be performed by BCVWD and the chemical system in the original design would be deleted. The changes address the chemical area near the recycled water pump station.

The original cost estimate for this was \$175,000. The cost for this work is \$404,821.33.

**Summary of Change Order No. 13 Costs:**

The costs for the change order are as summarized below and will not impact the project schedule:

Item	Cost
Item #1 - RO-Sulfuric Acid Chemical Piping Material Change	\$404,821.33
<b>Total:</b>	<b>\$404,821.33</b>

**Wastewater Treatment Plant Change Order Summary:**

CO No.	Description	Reason for Change	Amount
1	MBR System Improvements	Enhance the performance of MBR System	\$149,741.00
2	RO System Electrical Modifications & Storm Drain System Material Change	Design & Material Updates	(\$245.00)
3	New Aeration Basin 1 through 3 Excavation	Conflict with Existing Utilities	\$19,998.00
4	Structural and Mechanical Modifications	Pre-Selected Submittals	\$57,450.64
5	Vactor Truck Dump Station Modifications	Conflict with Construction	NTE \$15,000.00
6	EDI/Fine Coarse Bubble Diffuser Equipment	Design Change	\$24,298.00
7	Various Changes – MBR/RO Structural, Site Civil & Headworks	Design Changes	\$59,167.49

	<b>SCADA Design Modifications</b>		
<b>8</b>	<b>Various Changes - Demolition, Piping Realignment, Material Change, and Electric Actuated Valve Voltage Change</b>	<b>Unforeseen Conditions and Value Engineering</b>	<b>\$7,942.00</b>
<b>9</b>	<b>Various Changes - Solids Handling Bldg. Conveyor Capacity Increase, Electrical Yard Vaults Cover Changes, Additional Pothole Investigation and Existing Duct Bank Removal, and Yard Utilities</b>	<b>Design Changes, Conflict with Construction, Owner Requested Changes</b>	<b>\$138,531.73</b>
<b>10</b>	<b>MBR Chemical Area Changes &amp; Other Misc. Changes and Inclement Weather Impact Nov-18 to May-19</b>	<b>Owner Requested Changes &amp; Inclement Weather</b>	<b>\$596,031.05</b>
<b>11</b>	<b>Frontier Internet Provider Duct Bank Modifications, 30-inch MBR &amp; 20-inch Plant Effluent Pipeline Elevation and Alignment Modifications, Additional Safety Required Handrail at Retaining Wall and Generator</b>	<b>Design Changes, &amp; Conflict with Construction</b>	<b>\$81,128.29</b>
<b>12</b>	<b>RO-Sulfuric Acid Chemical Piping Material Change, Solids Feed Pump TE/TSH Thermocouple Elements, Solids Handling Bldg. Changes</b>	<b>Design Changes, Owner Requested Changes</b>	<b>\$91,417.26</b>
<b>13</b>	<b>Plant Effluent Chemical Area Changes</b>	<b>Owner Requested Changes</b>	<b>\$404,821.33</b>
<b>WWTP Contingency</b>	<b>Budget Amount</b>	<b>Change Orders 1-13</b>	<b>Remaining</b>
	<b>\$4,000,000.00</b>	<b>\$1,645,281.79</b>	<b>\$2,354,718.21</b>

**Fiscal Impact:**

Wastewater Treatment Plant Expansion/Renovation:

The project accounting below represents the status of funds should the change order be approved by City Council. A contingency balance of \$2,354,718.21 would remain should City Council approve this item.

<b>WWTP</b>	<b>Budget Amount</b>	<b>Paid to Date</b>	<b>Remaining</b>
Design	\$2,709,798.23	\$2,556,828.66	\$152,969.57
Construction Management	\$5,308,585.72	\$2,620,177.77	\$2,688,407.95
Equipment	\$252,906.00	\$253,293.50	(\$387.50)
Permits	\$324,776.76	\$79,058.64	\$245,718.12
Construction	\$53,910,737.00	\$26,788,463.64	\$27,122,273.36
Contingency	\$4,000,000.00	\$418,810.11	\$3,581,189.89
<b>Total</b>	<b>\$66,506,803.71</b>	<b>\$32,716,632.32</b>	<b>\$33,790,171.39</b>

**Recommended Action:**

Approval of Change Order No. 13 for the Wastewater Treatment Plant Upgrade/Expansion in the amount not to exceed \$404,821.33.

**Attachments:**

- A. Change Order No. 13 - Lyles



# City of Beaumont Wastewater Treatment Plant Salt Mitigation Upgrade Project Change Order No. 13

Dec 16, 2019

		Amount	Calendar Days	Comp. Date
Contractor:	W.M. Lyles Co.	Original Contract:	\$ 53,312,000.00	820 1/26/2021
Project Name:	Wastewater Treatment Plant Salt Mitigation Upgrade Project	Previous Approved Changes:	\$1,223,585.46	95 5/1/2021
Contract No.:	C18-80	This Change: Amount	\$404,821.33	0
CO Number:	13	Revised Contract:	\$54,940,406.79	915 5/1/2021
		Previous Phase 1 Completion Date		4/26/2020
		Revised Phase 1 Completion Date		4/26/2020

This change order covers changes to the subject contract as described herein. The Contractor shall supply all labor, equipment and materials to complete the Change Order items for the lump sum price agreed upon herein. All Change Order items must be submitted to the City for approval prior to fabrication.

Item No.	PCO No.	Description of Changes	Amount	Phase 1 Time Extension (CD*)	Phase 2 / Project Completion Time Extension (CD*)
1	28	DCM-13, CLAR-16, WML COP-028R2 Plant Effluent Chemical Area Changes	\$404,821.33	0	0
2			\$0.00	0	0
3			\$0.00	0	0
4			\$0.00	0	0
<b>NET CHANGE IN CONTRACT AMOUNT – INCREASE (OR-DECREASE)</b>			<b>\$404,821.33</b>	<b>0</b>	<b>0</b>

\*Calendar Days

The amount of the Contract will be increased/decreased by the amount of Four Hundred Four Thousand Eight Hundred Twenty-One Dollars and thirty-three cents (\$404,821.33). The Contract Time will be increased by zero (0) calendar days.

The Contractor agrees to furnish all labor, equipment and materials and to perform all other necessary work, inclusive of the directly or indirectly related work, within the approved time extension required to complete the above Change Order items. The undersigned Contractor approves the foregoing Change Order as to the changes, if any, in the Contract Price specified for each item including any and all supervision costs and other miscellaneous costs relating to the change in Work, and as to the extension of time allowed, if any, for the completion of the entire Work on account of said Change Order. The City and the Contractor hereby agree that this Change Order constitutes full mutual accord and satisfaction for all time, all costs, and all impacts related directly or indirectly to this Change Order. The Contractor hereby agrees that this Change Order represents the full equitable adjustment owed under the Contract, and further agrees on behalf of himself and all subcontractors to waive all right to file any further claims or request for equitable adjustment arising out of or as a result of this Change Order or the cumulative effect of this Change Order on the performance of the overall Work under the Contract. This document will become a supplement of the contract and all provisions will apply hereto. It is understood that the Change Order shall be effective when approved by the City.

Recommended: , Date: 12-16-2019  
MWH Constructors, Senior Resident Engineer

Accepted: , Date: 12-16-19  
W.M. Lyles Co., Contractor

Approved: \_\_\_\_\_, Date: \_\_\_\_\_  
Albert A. Webb Associates, Program Manager

Approved: \_\_\_\_\_, Date: \_\_\_\_\_  
City of Beaumont, City Manager



**Wastewater Treatment Plant Salt Mitigation Upgrade Project**  
**Technical Justification:**

PCO-28	
Design Adjustment: CLAR-16 / DCM-13 WML COP-028R2	Plant Effluent Chemical Area Changes

Owner Requested Change:

These requested changes are necessary to further condition treated effluent to meet new permit discharge requirements. Also further discussion with Beaumont Cherry Valley Water District it was decided that any chemical conditioning required for reuse discharge would be performed by BCVWD and the chemical system in the original design would be deleted.

Design and Scope Changes:

This clarification addresses the changes in the chemical area near the recycled water pump station. These changes consist of deleting the sodium hypochlorite chemical storage #2 as shown on drawings C-37 and C-38 (and associated dosing connection point for the recycled water line) and modifying the existing septage receiving station northwest of the Recycled Water Pump Station to function as a chemical containment area for one sodium bisulfite chemical tank and one caustic soda chemical tank. This area will also include the chemical dosing pumps for each system. The sodium bisulfite will be dosed over the effluent weir of the Recycled Water Pump Station and the caustic soda will be dosed in the influent box upstream of the UV channels. The dosing at the UV influent box will include a mechanical mixer (*Phase 2 Final Completion*). The dosing system at the Recycled Water Pump Station will be a static system but will include chlorine and pH analyzers and a combined controller connected to plant SCADA.

The modifications also include grading and yard piping changes associated with the chemical piping from the chemical storage area to the UV influent box and recycled water pump station. Updated P&ID and Electrical and instrumentation drawings are also included. In addition to drawings following specification sections are included:

- Specification 409113 – Chemical Properties Process Measurement Devices – The addition of chlorine and pH instruments.
- Specification 463344 – Peristaltic Pump – The addition of a sampling pump at the recycled water pump station.
- Specification 466250 – Vertical Shaft Turbine Mixer – The addition of a vertical shaft mixer at the UV influent box, which is to be installed in the early stage of Phase 2.
- Note that the packaged chemical feed system specification (Section 433269) shall apply for both the sodium bisulfite and caustic soda applications.
- Note that the HDXLP Chemical Storage Tanks specification (434143) that was reissued with Clarification 12 is applicable to this clarification.

Cost Impact:

The contractor’s initial quote in the amount of \$428,003.24 was amended by the contractor and increased to \$437,543.31 after the electrical contractor realized that cost of new area lighting requested in the design change was not included in the first quote. MWHC evaluated the extra cost proposal by the Contractor and requested labor and equipment adjustments from the contractor be resulting a cost decrease. MWHC also discussed with the City and Design Engineer the use of existing area lighting and the use of an existing good condition electrical distribution panel that is to be demolished in Phase 1 be repurposed at the new chemical storage area.

MWHC recommends a contract cost increase of \$404,821.33 to be executed in a change order for changes to the Plant Effluent Chemical Bulk Storage Tank Area.

**Wastewater Treatment Plant Salt Mitigation Upgrade Project**  
**Technical Justification:**

PCO-28	
Design Adjustment: CLAR-16 / DCM-13 WML COP-028R2	Plant Effluent Chemical Area Changes

Owner Requested Change:

These requested changes are necessary to further condition treated effluent to meet new permit discharge requirements. Also further discussion with Beaumont Cherry Valley Water District it was decided that any chemical conditioning required for reuse discharge would be performed by BCVWD and the chemical system in the original design would be deleted.

Design and Scope Changes:

This clarification addresses the changes in the chemical area near the recycled water pump station. These changes consist of deleting the sodium hypochlorite chemical storage #2 as shown on drawings C-37 and C-38 (and associated dosing connection point for the recycled water line) and modifying the existing septage receiving station northwest of the Recycled Water Pump Station to function as a chemical containment area for one sodium bisulfite chemical tank and one caustic soda chemical tank. This area will also include the chemical dosing pumps for each system. The sodium bisulfite will be dosed over the effluent weir of the Recycled Water Pump Station and the caustic soda will be dosed in the influent box upstream of the UV channels. The dosing at the UV influent box will include a mechanical mixer (*Phase 2 Final Completion*). The dosing system at the Recycled Water Pump Station will be a static system but will include chlorine and pH analyzers and a combined controller connected to plant SCADA.

The modifications also include grading and yard piping changes associated with the chemical piping from the chemical storage area to the UV influent box and recycled water pump station. Updated P&ID and Electrical and instrumentation drawings are also included. In addition to drawings following specification sections are included:

- Specification 409113 – Chemical Properties Process Measurement Devices – The addition of chlorine and pH instruments.
- Specification 463344 – Peristaltic Pump – The addition of a sampling pump at the recycled water pump station.
- Specification 466250 – Vertical Shaft Turbine Mixer – The addition of a vertical shaft mixer at the UV influent box, which is to be installed in the first 60-day of Phase 2.
- Note that the packaged chemical feed system specification (Section 433269) shall apply for both the sodium bisulfite and caustic soda applications.
- Note that the HDXLP Chemical Storage Tanks specification (434143) that was reissued with Clarification 12 is applicable to this clarification.

Cost Impact:

The contractor’s initial quote in the amount of \$428,003.24 was amended by the contractor and increased to \$437,543.31 after the electrical contractor realized that cost of new area lighting requested in the design change was not included in the first quote. MWHC evaluated the extra cost proposal by the Contractor and requested labor and equipment adjustments from the contractor be resulting a cost decrease. MWHC also discussed with the City and Design Engineer the use of existing area lighting and the use of an existing good condition electrical distribution panel that is to be demolished in Phase 1 be repurposed at the new chemical storage area.

MWHC recommends a contract cost increase of \$404,821.33 to be executed in a change order for changes to the Plant Effluent Chemical Bulk Storage Tank Area.

## CITY OF BEAUMONT WWTP SALT MITIGATION UPGRADE PROJECT

CHANGE ORDER PROPOSAL (COP) # 028.3  
(By Contractor)

<b>To (Engineer/CM):</b> MWH Constructors Attention: Charles Reynolds Phone: 702-497-8024 Email: Charles.w.reynolds@mwhconstructors.com	<b>From (Contractor):</b> W.M. Lyles Co. Attention: Juan C. Ahumada Phone: 951-972-2056 Email: jahumada@wmlylesco.com
<b>PCO/DCM No.:</b> DCM#13	
<b>Subject:</b> Plant Effluent Chemical Area Changes	
<b>Reference Documents:</b> Clarification no. 16	
<b>DESCRIPTION</b>	
<p>This change order proposal addresses the changes in the chemical area near the recycled water pump station. These changes consist of deleting the sodium hypochlorite chemical storage #2 as shown on drawings C-37 and C-38 (and associated dosing connection point for the recycled water line) and modifying the existing septage receiving station northwest of the Recycled Water Pump Station to function as a chemical containment area for one sodium bisulfite chemical tank and one caustic soda chemical tank. This area will also include the chemical dosing pumps for each system. The sodium bisulfite will be dosed over the effluent weir of the Recycled Water Pump Station and the caustic soda will be dosed in the influent box upstream of the UV channels. The dosing at the UV influent box will include a mechanical mixer. The dosing system at the Recycled Water Pump Station will be a static system but will include chlorine and pH analyzers and a combined controller connected to plant SCADA.</p> <p>The modifications also include grading and yard piping changes associated with the chemical piping from the chemical storage area to the UV influent box and recycled water pump station</p> <p><b>This change order is no longer valid after January 7<sup>th</sup>, 2020.</b></p>	
<b>COST ESTIMATE</b>	
Total Cost \$ 404,821.33 – see attached breakdown	
<b>SCHEDULE IMPACT</b>	
<p>The change order results in no delay to the schedule contingent upon the following:</p> <ol style="list-style-type: none"> <li>1. Executed change order by no later the January 7<sup>th</sup>, 2020.</li> <li>2. All new work associated with the existing UV influent box (vertical shaft mixer, piping, electrical, etc.) will be completed as part of Phase 2.</li> </ol>	
<b>Received by MWH Constructors (Date):</b>	

RESPONSE	
<b>Response By:</b>	<b>Date:</b>

Final Distribution: Juan C. Ahumada, W.M. Lyles Co.  
Brian Knoll, Webb Associates  
MWH Inspector

W. M. Lyles Co.  
 42142 Roick Drive  
 Temecula, CA 92590

Date: 12-Dec-19

Reference #: Clar. 16

Attention: Charles W. Reynolds

JOB LOCATION: City of Beaumont WWTP Salt Mitigation Upgrade Project

DESCRIPTION: Effluent Chemical Area Changes

Item:		Unit	Total MH	Total MH Cost	Eq. Cost	Material	Subcont.	Total Cost
1	Chemical Storage Area #2	1 LS	669	\$ 52,917.04	\$ 13,936.73	\$ 117,734.33	\$ 43,132.71	\$ 227,720.81
2	Recycled Water Lift Station	1 LS	69	\$ 5,221.99	\$ 1,063.24	\$ 18,726.64	\$ 41,243.83	\$ 66,255.70
3	UV Disinfection Area	1 LS	70	\$ 5,473.76	\$ 1,931.26	\$ 35,997.82	\$ 20,252.00	\$ 63,654.84
		1 LS	0	\$ -	\$ -	\$ -	\$ -	\$ -
Total Costs			808	\$ 63,612.79	\$ 16,931.23	\$ 172,458.79	\$ 104,628.54	\$ 357,631.35

Subtotal	\$	357,631.35
Mark-up - Labor	15%	\$ 9,541.92
Mark-up - Equipment	15%	\$ 2,539.68
Mark-up - Materials	15%	\$ 25,868.82
Mark-up - Subcontractor	5%	\$ 5,231.43
Bond	1.0%	\$ 4,008.13
<b>Total This Change Order</b>	<b>\$</b>	<b>404,821.33</b>

Comments:

City of Beaumont WWTP Salt Mitigation Upgrade Project  
 Chemical Storage Area #2

A. Labor

Description	Lab Pipe FM			Lab Pipe			Operator			Carp FM			Carp			Lab			Cement Mason		
	ST	PT	DT	ST	PT	DT	ST	PT	DT	ST	PT	DT	ST	PT	DT	ST	PT	DT	ST	PT	DT
Buried Chem & PW Pipe Ex/BF - Credit - 105 LF	(24)			(45)			(24)														
Buried Chem & PW Pipe Ex/BF - 320 LF	72			144			72														
Install Buried Chem & PW Pipe - Credit - 105 LF	(6)			(12)			(6)														
Install Buried Chem & PW Pipe - 320 LF	18			36			18														
AC Paving Demo - 345 SF	8			16			8														
Sawcutting AC Paving	4			4																	
Seplage Receiving Concrete Demo - 13 CY	16			32			16														
Chem Storage #2 concrete form/strip credit										(16)			(32)			(6)					
Chem Storage #2 place concrete 14 cy credit																(6)					
Chem Storage #2 finish, cure, etc credit										(6)			(12)			(6)					
Concrete Mods - form/strip										14			14			14					
Concrete Mods - Drill & Epoxy Dowels										16			16			16					
Concrete Mods - place concrete																					
Concrete Mods - finish, cure, etc.										10			10								10
Install leak detection system	4			8																	
Install tanks, trim, ladder, restraints & Heat Trace/Insulation	48			96			8														
Chem Storage #2 pipe & tank install credit	(16)			(32)			(4)														
Chem tank area pipe, supports, pumps	32			64																	
Install Pump Skid - Credit	(3)			(6)																	
Install Pump Enclosure, FRP Stand	8			16																	
Install Dynarail FRP safety ladder rails										8			8								
Install Heat Tracing	8			16																	
Cut and cap existing trench drain pipe	4			4			4														
	###	0	0	338	0	0	92	0	0	26	0	0	4	0	0	26	0	0	10	0	0

Name	Rate			Hours			Extension
	ST	PT	DT	ST	PT	DT	
Lab Pipe FM	\$77.80		\$103.90	\$129.98	173	0	\$13,460.13
Lab Pipe	\$75.19		\$99.97	\$124.75	338	0	\$25,413.61
Operator	\$96.33		\$128.99	\$161.66	92	0	\$8,862.75
Carp FM	\$85.03		\$115.33	\$145.63	26	0	\$2,210.80
Carp	\$81.11		\$109.45	\$137.79	4	0	\$324.43
Lab	\$71.72		\$94.78	\$117.82	26	0	\$1,864.77
Cement Mason	\$78.05		\$102.25	\$126.45	10	0	\$780.55
0	\$0.00		\$0.00	\$0.00	0	0	\$0.00
0	\$0.00		\$0.00	\$0.00	0	0	\$0.00
					669	0	
							<b>Total Labor = \$82,917.04</b>

B. Equipment

Description	17.12	32.037	31.028	30.048	20.041	77.02	14.037
Buried Chem & PW Pipe Ex/BF - Credit - 105 LF	(24)			(24)			
Buried Chem & PW Pipe Ex/BF - 320 LF	72			72			
Install Buried Chem & PW Pipe - Credit - 105 LF	(6)			(6)			
Install Buried Chem & PW Pipe - 320 LF	18			18			
AC Paving Demo - 345 SF	8			8			
Sawcutting AC Paving & Concrete	4			4			
Seplage Receiving Concrete Demo - 13 CY	16			16			
Chem Storage #2 concrete form/strip credit			(8)				
Chem Storage #2 place concrete 14 cy credit			(3)				
Concrete Mods - form/strip	14		14				
Concrete Mods - Drill & Epoxy Dowels	16		4				
Concrete Mods - place concrete							
Concrete Mods - finish, cure, etc.	12		2				
Install leak detection system	4						
Install tanks, trim, ladder, restraints & Heat Trace/Insulation	48		8				
Chem Storage #2 pipe & tank install credit	(16)		(4)				
Chem tank area pipe, supports, pumps	32						
Install Pump Skid - Credit	(3)						
Install Pump Enclosure, FRP Stand	8						
Install Dynarail FRP safety ladder rails							
Install Heat Tracing	16						
Cut and cap existing trench drain pipe	4			4			
	231	9	4	92	0	0	0

Number	Description	Rate	Hours	Extension
17.12	Foreman Truck	\$29.60	231	\$6,837.60
32.037	ReachitXtremeXR1055	\$58.61	9	\$527.49
31.028	Hydro Crane - 80 Ton Link BeRTC-8080 II 80 Ton	\$164.01	4	\$656.04
30.048	Loader Backhoe 410 John Deere 410L	\$64.30	92	\$5,915.60
20.041	Excavator John Deere 390GLC	\$151.12	0	\$0.00
77.02	Scissor Lift JLG 2646ES	\$20.04	0	\$0.00
17	Foreman Truck	\$29.60	0	\$0.00
			336	
				<b>Total Equipment = \$13,938.73</b>

C. Materials

	Quantity	Unit	Price	Extension
Concrete 7add, minus 14 credit	-7	CY	\$ 150.00	-\$1,050.00
Form, waterstop, sealant, chamfer etc	1	LS	\$ 2,019.00	\$2,019.00
Demo Dump Fees	4	lds	\$ 250.00	\$1,000.00
Sodium Hypo Chem Metering pump credit	1	EA	\$ (14,365.00)	-\$14,365.00
New Chemical metering pump skids	2	EA	\$ 15,865.00	\$31,730.00
Dynarail FRP Safety Ladder	2	EA	\$ 1,408.00	\$2,816.00
Chem Tank Credit	1	LS	\$ (21,040.00)	-\$21,040.00
New Chem Tanks - Poly Processing	1	LS	\$ 50,188.00	\$50,188.00
New Radar Units	2	EA	\$ 2,590.00	\$5,180.00
Grout	1	LS	\$ 100.00	\$100.00
Leak detection system	1	LS	\$ 9,498.00	\$9,498.00
Heat Tracing Material	1	LS	\$ 10,554.00	\$10,554.00
FRP enclosure w/fan + 3/4" FRP plate	2	EA	\$ 8,298.00	\$16,596.00
PVC pipe, Fittings, tubing & HDPE - Underground	1	LS	\$ 2,812.80	\$2,812.80
PVC pipe, Fittings, Supports, Valves, Etc - Aboveground	1	LS	\$ 5,930.10	\$5,930.10
Misc items and consumables	669	MHF	\$ 3.50	\$2,341.50
Additional Gravel Material	1	LS	\$ 450.00	\$450.00
				\$0.00
Tax	7.750%			\$8,118.93
Commissioning, Schedule Support				\$1,475.00
Freight	1		3380	\$3,380.00
				<b>Total Material = \$117,734.33</b>

D. Subcontractor

	Quantity	Unit	Price	Extension
Rebar	1	LS	-\$6,127.00	-\$6,127.00
Concrete Pumping	-7	CY	\$20.00	-\$140.00
Electrical & Instrumentation	1	LS	\$37,972.71	\$37,972.71
Pipe coating	86	LF	\$6.00	\$516.00
Pipe Insulation	1	LS	\$8,361.00	\$8,361.00
Seismic Calcs Engineering	1	LS	\$750.00	\$750.00
Concrete sawcutting	12	HR	\$150.00	\$1,800.00
				\$0.00
				\$0.00
				<b>Total Subcontract = \$43,192.71</b>











Southern Contracting Company  
 P.O. Box 445 San Marcos, CA 92079-0445  
 Tel 760-744-0760 Fax 760-744-6475  
 website: www.southerncontracting.com  
 email: info@southerncontracting.com

## Change Order Request

**103801 — Wastewater Treatment Plant Salt Mitigation Upgrade**

**COR Subject: DCM-013 CLAR-016 Eff Chem Changes No. 2**

**To** Juan C. Ahumada  
 W.M. Lyles  
 42142 Roick Drive  
 Temecula, CA 92590  
 951-973-7393

**Contract No: 55.1173**  
**COR Number: 103801-COR#013**  
**COR Revision Number: 0**

**COR Date: 10/18/2019**  
**Work Type: Price / Do Not Proceed**

**Return To** Dan Alcantar  
 Southern Contracting Company  
 760-744-0760x621  
 619-778-0681  
 DAlcantar@southerncontracting.com

**Other Reference No: DCM-013 CLAR-016**  
**Days Valid: 5**

### Scope Of Work / Time Extension Request

The work associated with DCM13 CLAR 16 Effluent Chem Area changes No.2 is a change to Southern Contracting Company's scope of work in which a change in Contract Price and Time is to be considered.

Accordingly, Southern Contracting Company requests a Contract Change Order in the amount of \$97,596.54

Scope of Work is as follows:

- Provide Materials and labor to complete the electrical work as depicted in CLAR-016. We will install duct bank/ concealed conduit, exposed conduit, wire and cable, supports, wire, wire terminations as depicted in the document. Further, we will provide one 30amp breaker, overloads and a timer relay and labor to modify one MCC Started bucket in existing MCC-UV for MX-6103, Relocate Panel LP-HW1 (Existing), Heat Trace Controllers, Instrument controllers and control panels. Loop documentation is included. Relocate Existing Light Pole.

Exclusions:

- Heat Trace cable, Heat Trace cable installation is not included.
- Electrical equipment procurement of LP-RW
- duct bank concrete encasement and rebar.
- Pipe, Tubing, Process pipe fittings, Digging, Backfill, Concrete formed or poured, Dry packing, Surface restoration, Permits, Fee's, Inspections.
- New Lighting Fixtures

Change in time: addition 10 working days to install.  
 14 weeks for procurement after executed change Order.

Southern Contracting reserves all rights to additional costs and time for changes not identified in the documents furnished, and is not responsible for additional costs or time for work which is not part of our contract scope of work, unless stipulated above. Should additional information or clarification be required, please

contact me at your convenience.

---

**Summary**

**Total:** \$97,596.54

---

**Reservation of Rights**

This COR does not include any amount for impacts such as interference, disruptions, rescheduling, changes in the sequence of work, delays and/or associated acceleration. We expressly reserve the right to submit our request for any of these items.

---

Signed By:



Daniel Alcantar  
PM

Dated: 10/18/2019

**Bid Summary Report**

103801 Beaumont Chang Orders Estimator: Dan Alcantar

Job #2336

**Job Name:** 103801 Beaumont Chang Orders

**Contractor:**

**Estimator:** Dan Alcantar

**Notes:**

**Bid Date:**

Summary Description	Material			Labor		
	Extended	%	Adjusted	Extended	%	Adjusted
COR#013 DCM-013 CLAR-016 Effluent Chem Tank Area	\$8,926.08	100.00%	\$8,926.08	294.40	100.00%	294.40

**Top Sheet**

Raw Cost	\$83,424.75	Sales per Month	\$0.00
Tax	\$691.77	Return per Month	\$0.00
Raw Cost with Tax	\$84,116.52	Price per Square Foot	\$0.00
Overhead	\$12,513.71	Hours per Square Foot	0.00
Profit	\$0.00	Square Feet	0.00
Total Return Amount	\$12,513.71	Job Months	0.00
Total Return %	12.82%	Hours per Week	0.00
Price	\$96,630.23	Workers per Day	0.00
Bond	\$966.30	Total Hours	294.40
Sell Price	<b>\$97,596.54</b>	Mark Up Sales Tax	Yes
Adjusted Sell ()	\$0.00	Use Bond Table	Yes
Adjusted Sell Return	0.00 %		\$0.00

**Labor**

Class Description	Percent of Total	Hours Distributed	Hourly Rate	Burden		Labor Cost
				Rate	Percent	
General Foreman	10.00%	29.44	\$90.37	\$0.00	0.00%	\$2,660.52
Journeyman	50.00%	147.20	\$78.19	\$0.00	0.00%	\$11,509.69
Appr-85%	40.00%	117.76	\$68.10	\$0.00	0.00%	\$8,019.54
<b>Totals</b>	<b>100.00%</b>	<b>294.40</b>	<b>\$75.37</b>	<b>\$0.00</b>	<b>0.00%</b>	<b>\$22,189.75</b>

**Mark Ups**

	OVERHEAD			PROFIT		
	Total	%	Amount	%	Amount	
Materials	\$8,926.08	+ 15.00%	\$10,265.00	+ 0.00%	\$10,265.00	
Labor	\$22,189.75	+ 15.00%	\$25,518.21	+ 0.00%	\$25,518.21	

### Bid Summary Report

103801 Beaumont Chang Orders Estimator: Dan Alcantar

Job #2336

Supplier Quotes	\$49,610.00 + 15.00%	\$57,051.50 + 0.00%	\$57,051.50
SubContractors	\$0.00 + 5.00%	\$0.00 + 0.00%	\$0.00
Direct Job Expense	\$2,698.92 + 15.00%	\$3,103.76 + 0.00%	\$3,103.76
Equipment Rental	\$0.00 + 15.00%	\$0.00 + 0.00%	\$0.00
<b>Totals</b>	<b>\$83,424.75 15.00%</b>	<b>\$95,938.46 0.00%</b>	<b>\$95,938.46</b>

#### Tax Report

	Taxed Amount	Tax Rate %	Tax Amount
Materials	\$8,926.08	7.75%	\$691.77
Labor	\$22,189.75	0.00%	\$0.00
Supplier Quotes	\$1,650.00	0.00%	\$0.00
SubContractors	\$0.00	0.00%	\$0.00
Direct Job Expense	\$0.00	0.00%	\$0.00
Equipment Rental	\$0.00	0.00%	\$0.00
		<b>Total Tax:</b>	<b>\$691.77</b>

#### Supplier Quotes

Name	Supplier	Tax (0.0 %)	Unit Cost	Multiplier	Amount
Intrumentation and controls		No	\$47,960.00	1.00	\$47,960.00
Add to existing MCC		Yes	\$1,650.00	1.00	\$1,650.00
				<b>Total:</b>	<b>\$49,610.00</b>

#### Direct Job Expense

Name	Supplier	Tax (0.0 %)	Unit Cost	Multiplier	Amount
Site Truck		No	\$18.36	147.00	\$2,698.92
				<b>Total:</b>	<b>\$2,698.92</b>



**Scope Letter: 2 pages**



Technical Systems Incorporated

2303 196th Street SW  
Lynnwood, WA 98036  
Tel: (425) 775-5696  
Fax: (425) 775-9074  
info@tsicontrols.com

October 21, 2019

Quote Number: CO#03R1

To: Southern Contracting  
Attn: Dan Alcantar

Project: Beaumont WWTP Salt Mitigation  
Beaumont Wastewater Treatment Plant

Reference: **CLAR-16 Effluent Chem Area Changes**

Bid Date: N/A

Bid Time: N/A

Technical Systems, Inc. (TSI) is pleased to provide a quote for the above referenced project. Material for this project will be shipped FOB Lynnwood WA, complete, ready for field termination by others. TSI's price includes CA sales tax and does not include the cost to bond TSI's portion of the project.

TSI's price for the scope of work detailed on the following pages:

**Change Order Proposal Pricing:**

~~\$60,400.00~~

**\$47,960.00**

**Change Scope as Follows:**

*(Per RFI 092 response, CLAR-16 is being quoted with a Hach SC4200 instead of the referenced Hach SC200)*

- Complete Analyzer Instrument panel per RWM-4:
  - o 60"Hx36"Wx16"D 304SS enclosure with 12"H Floor Mount Leg Kit
    - Freestanding Stainless Steel enclosure with full backpan
      - Note: 304SS panel is recommended over the part number given on RWM-4 for this location and application
      - Drip Kit SCE-DS36SS
      - Breather Vent SCE-BVK
    - Replaces need for separate strut support shown on RWM-4
    - Engineering Seismic Calculations Included
  - o AIT-7472 – Hach SC4200c, 2-channel transmitter
    - External USB Box (required for Ethernet Connection)
    - USB to Ethernet Adapter (required for Ethernet Connection)
    - M12 to RJ45 Network Adapter
    - Hach Configuration and Provisioning of SC4200c
    - NOTE: Per Hach, Subscription fees are required for the Hach SC4200 system and are to be purchased by the owner from Hach. This is not specific to CLAR-16.
  - o AE-7472 – Hach pH probe
    - 1" NPT Flow Cell Assembly (CPVC Only)
  - o AE-7473 – Hach CL17sc Chlorine Analyzer
    - Includes CL-17 Installation kit with pressure regulator
    - Spares as noted in spec:
      - Y-Mesh strainer and 2 spares
        - o Note Hach recommends 40 Mesh
      - 6 Tubing kits for recommended bi-annual maintenance for 3 years

- 36 Cell cleaning kits, monthly maintenance for 3 years
  - 36 Total Chlorine Reagent Sets, monthly for 3 years
- Supply Local Control Panels:
    - LCP-P-7471 – Sample Pump Panel per PI-19 and schematic E-26
      - 304SS enclosure
    - LCP-7410 & LCP-7511 – Sodium Bisulfite Pump and Sodium Hydroxide Pump
      - Design based on E-26 Chem Pump Schematic without Valve Control
      - 304SS Enclosures, 24x24x12
      - NEMA 0 Starter with SSOLR
      - 20 main CB, 10A CB each pump
      - DI/DO and AI/AO as shown on PI-19
        - Pass-Through terminals only for the analogs
      - 120VAC System per drawings
  - Add I/O to PLC Panel Drawings as shown (No added material quoted)

Terms: Net 30  
 FOB: Lynnwood WA  
 Freight: Prepaid

This quote is valid for 90 days.

Please call with any questions you may have concerning pricing or any technical questions.

Sincerely,

*Colin Dightman-Kovak*

Colin Dightman-Kovak  
 Technical Systems, Inc.  
 1-425-678-4116

### **Scope of Work**

#### **Misc Equipment:**

Including:

1. Hardware Procurement
2. Required Testing
3. O&M, drawings updates

### **GENERAL**

1. TSI supplies a bill of materials, CAD-based drawings, and Operations and Maintenance Manuals for all equipment furnished by TSI.
2. TSI supplies the required field startup service 306 s project.

3. Panels fabricated by TSI are UL 508 labeled.

### **STANDARD INCLUSIONS**

We provide the following unless specifically excluded on our bill of material:

- 1) Equipment shipped FOB factory with freight allowed, tailgate, destination.
- 2) Field wiring diagrams showing interconnection of field instruments and instrumentation panels.
- 3) Instruction manuals as required.
- 4) All necessary field start-up and calibration of the equipment we supply.

### **STANDARD EXCLUSIONS**

We do **NOT** include the following unless specifically included in our bill of material:

- 1) Pipe, tubing, valves or fittings between the instrument and the process.
- 2) Conduit, wire or cable not an integral part of the instrument.
- 3) Mounting brackets, stanchions, supports or mounting pads not an integral part of the instrument.
- 4) Labor to install the equipment.
- 5) The Cost, (if due to local union regulations), to have local craftsman make adjustments or wiring modifications to our equipment during start-up and calibration.
- 6) Any material or services not in our quoted sections.
- 7) This proposal is based on award of a supply purchase order and does not include any of the costs associated with bonding or subcontract administration. If bonding or a subcontract is required they can be provided for additional cost.

### **SPECIFIC EXCLUSIONS**

- 1) Installation of Panels.



Beaumont WWTP Salt Mitigation  
TSI Project No. 7781

TSI Change Order No.: 3R1	Description:	Amount	Units	Rate	Notes
Category	Effluent Chem Area Changes				
Project Management - design/fabrication	8		Hours	\$160.00/Hr	Management, Design Review
Project Management - programming/commissioning	0		Hours	\$160.00/Hr	
Engineering	48		Hours	\$150.00/Hr	24 for inst panel, 8 each for 3 others - Panel Design
Programming	0		Hours	\$150.00/Hr	
Field Engineering	40		Hours	\$135.00/Hr	16hrs panel shop testing plus 24 Start-Up
Travel Time (Field Engineering)	9		Hours	\$135.00/Hr	3 hr travel each for 3 days
Fabrication	132		Hours	\$110.00/Hr	60 for inst panel, 24 each for others
Engineering Support (O&Ms, submittals)	8		Hours	\$65.00/Hr	Submittal, O&M
CAD	20		Hours	\$75.00/Hr	CAD
Labor Total	\$31,635.00				
Travel Expenses	\$300.00				by car. 3 days SU @ 100/day gas/meals
Freight Expenses	\$571.60				Two shipments - LCP's and Instrument pnl
Subcontractors Cost	\$0.00				
Materials	\$24,087.57				
SUBTOTAL:	\$56,594.17				
Bonding @ % of Subtotal:	\$0.00		0.00%		Bond Rate (if applicable)
Tax:	\$3,805.84		7.75%		Tax Rate (if taxable)
<b>TOTAL COST:</b>	<b>\$60,400.00</b>				
Notes:					



MATERIAL COST ESTIMATE			
Quantity	Cost	Ext. Cost	Part #
0	\$0.00	\$0.00	
1	\$3,108.87	\$3,108.87	SCE-60EL3616SSLPPL
1	\$226.00	\$226.00	SCE-60P36F1
1	\$2,095.25	\$2,095.25	
1	\$2,020.40	\$2,020.40	LXV524.99.011120 + acc
1	\$926.50	\$926.50	DPD1P1
1	\$294.95	\$294.95	
1	\$3,211.95	\$3,211.95	
1	\$170.98	\$170.98	
1	\$500.00	\$500.00	
1	\$600.00	\$600.00	
1	\$496.72	\$496.72	SCE-FK1216SS
0	\$0.00	\$0.00	
1	\$1,218.22	\$1,218.22	SCE-24EL2410SSLPL
1	\$53.18	\$53.18	SCE-24P24
1	\$25.00	\$25.00	
1	\$50.00	\$50.00	
1	\$100.00	\$100.00	
1	\$100.00	\$100.00	
1	\$120.00	\$120.00	T02CN13G7
1	\$25.00	\$25.00	
1	\$50.00	\$50.00	
1	\$200.00	\$200.00	
1	\$20.00	\$20.00	
0	\$0.00	\$0.00	
2	\$1,218.22	\$2,436.44	SCE-24EL2410SSLPL
2	\$53.18	\$106.36	SCE-24P24
4	\$35.00	\$140.00	
2	\$50.00	\$100.00	
2	\$50.00	\$100.00	
2	\$500.00	\$1,000.00	
0	\$0.00	\$0.00	
1	\$129.14	\$129.14	
1	\$20.75	\$20.75	
1	\$1,300.00	\$1,300.00	
0	\$0.00	\$0.00	
0	\$0.00	\$0.00	V6EPS-S-4-S-RV
0	\$0.00	\$0.00	Materials Cost Subtotal
		<del>-\$20,945.71</del>	
		\$0.00	Materials Cost Inflation (for parts to be purchased more than 6-months out)
		\$20,945.71	Materials Cost + Inflation (if applicable)
		\$3,141.86	Markup
		<del>\$24,887.57</del>	TOTAL Material Cost + Markup
		<b>\$19,622.35</b>	



# Bid

**Quote Number: 100498777v3**  
 Use quote number at time of order to ensure that you receive prices quoted

Hach  
 PO Box 608  
 Loveland, CO 80539-0608  
 Phone: (800) 227-4224  
 Email: quotes@hach.com  
 Website: www.hach.com

Quote Date: 10/16/2019

Quote Expiration: 12/15/2019

Technical Systems, Inc.  
 2303 196TH Street SW Suite B  
 Lynnwood, WA 98036-7071

Name: Colin Dightman-Kovak  
 Phone: 425-678-4168  
 Email: Colind@tsicontrols.com

Customer Account Number : 112896  
 Customer Quote Reference: City of Beaumont, CLAR-16 Items, CA

Sales Contact: Devin Locke Email: devin.locke@hach.com Phone: 909-264-0560

## PRICING QUOTATION

Line	Part Number	Description	Qty	Net Unit Price	Extended Price
<b>CLAR-16 Items</b>					
1	LXV524.99.01120	SC4200c Controller, w/o plug, 3G/4G US ATT, mA outputs, 2 Digital Sensors Inputs, Hach	1	1,190.45	1,190.45
2	LXZ524.99.00016	SC4200c External USB Box V2	1	135.15	135.15
3	LZY990	Network Cable, M12 to RJ45	1	58.39	58.39
4	LZY472-01	USB 2.0 Ethernet-Adap. for SC Service Port	1	44.41	44.41
5	MSM-STARTUP	SC4200c Controller - Configuration and provisioning of the MSM-enabled controller and connected sensors. Charges are per controller.	1	592.00	592.00
6	DPD1P1	pHD sc, Differential pH Digital Sensor, PEEK Body Material, Convertible Body Style, General Purpose Glass Electrode, 70 C (158 F) Maximum Temperature, 32.8' Cable, Hach	1	926.50	926.50
7	9180100	Flow Cell Assembly, 1" NPT Sensor (Note: This kit is only offered in a CPVC material.)	1	294.95	294.95
8	8573000	CL17sc Colorimetric Total Chlorine Analyzer, (1) Month Supply of Total Chlorine Reagents, Pressure Regulator Installation Kit, User Manual (Hach sc Controller is required for operation and sold separately.)	1	2,095.25	2,095.25
Note: The required yearly subscription fees are required and will need to be					



Line	Part Number	Description	Qty	Net Unit Price	Extended Price
		purchased prior to use of the instrumentation. It is the understanding that the software subscriptions will be purchased directly by the end user upon release of the instrumentation.			14.
Subtotal					\$ 5,337.10
<b>Spare Parts</b>					
9	5418300	Strainer Y-Body, 40 Mesh Screen	3	107.95	323.85
10	8560400	Tubing Kit, CL17sc	6	79.05	474.30
11	8573100	Cell Cleaning Kit, CL17sc	36	13.34	480.24
12	2557000	Total Chlorine Reagent Set, DPD (includes indicator and buffer. For Rapid Liquid Method, CL17 Process Analyzer, and bulk analytical methods)	36	53.71	1,933.56
Subtotal					\$ 3,211.95
Grand Total					\$ 8,549.05

## NOTES

**\*\*NOTE: FREIGHT IS NOT INCLUDED IN THE GRAND TOTAL PRICE\*\***

See attached freight schedule for estimated charges

Hach is providing a quotation for the instrumentation above. Hach is not responsible for any other requirements outside of the instrumentation quoted above. The instrumentation is based on the written specifications provided.

For further clarification, see attached document, project clarifications.

### Project Clarifications

As an instrument manufacturing company Hach can only be responsible for supplying the pertinent analytical instrumentation as well as any required manufacturer startup services or training. All other project requirements will be the responsibility of the contractor/integrator.

Pricing has been offered based on the instrument specifications provided to Hach Company. It will be the responsibility of the requestor to verify that all instrumentation and quantities offered are accurate. If it is found there are any discrepancies it will be the responsibility of the requestor to obtain revised pricing as required from Hach Company.

Listed below are the required project clarifications that need to be reviewed and verified by the requestor. It is the responsibility of the requestor to ensure all instrumentation requirements for the project have been addressed.

### PART 1 – GENERAL PROJECT REQUIREMENTS:

Hach Company was not supplied actual instrument specifications for the instrumentation being offered, since actual instrument specifications were not provided it will be the responsibility of the requestor to verify that the instrumentation being offered will meet all application and project requirements.

If there is other pertinent project information, it is the responsibility of the requestor to supply Hach Company with the additional sections containing the information related to the products and services quoted.

Standard Hach Company submittal packages, O&M manuals, and drawings can be supplied at the request of the customer. Custom formatting of any submittal packages, data sheets, manuals, or drawings is not available. Documentation can be supplied electronically via email. Documentation cannot be downloaded to any type of FTP or 3rd party site.

One (1) copy of the standard Operation & Maintenance Manual is supplied with the instrumentation at time of shipment. Additional copies can be downloaded at [www.hach.com](http://www.hach.com) for no additional charge.

The instrumentation has been offered with standard warranty terms. Extended warranties for up to a (3) year warranty term can be purchased for an additional charge if required. All warranties go into effect the day the instrumentation ships from the factory.

Standard lead time for instrumentation is (30) days ARO.

### PART 2 – PRODUCT:

#### GENERAL REQUIREMENTS:

The instrumentation is supplied with the necessary fuses; however, it will be the responsibility of the contractor/integrator to supply any required surge or lightning protection as Hach Company cannot supply these items.

Hach Company is an instrument manufacturer and is unable to supply any type of instrument enclosures such as, but not limited to: NEMA 4X Stainless Steel, any type of Stainless Steel Enclosure, Enclosures with Heating or Cooling elements, or Enclosures with Condensers, instrument back panels, or





**HACH COMPANY**

**Headquarters**  
 P.O. Box 389  
 5600 Lindbergh Drive  
 Loveland, CO 80539-0389

**Purchase Orders**  
 PO Box 608  
 Loveland, CO 80539-0608

**WebSite:** www.hach.com

**U.S.A.**  
 Phone: 800-227-4224  
 Fax: 970-669-2932  
 E-Mail: orders@hach.com  
 quotes@hach.com  
 techhelp@hach.com

**Export**  
 Phone: 970-669-3050  
 Fax: 970-461-3939  
 Email: intl@hach.com

**Remittance**  
 2207 Collections Center Drive  
 Chicago, IL 60693

**Wire Transfers**  
 Bank of America  
 231 S. LaSalle St.  
 Chicago, IL 60604  
 Account: 8765602385  
 Routing (ABA): 071000039

Quotation Addendum

**ADVANTAGES OF WORKING WITH HACH**

<p><b>Hach Service</b></p> <p><i>Protect your investment &amp; peace of mind</i></p> <ul style="list-style-type: none"> <li>✓ A global partner who understands your needs</li> <li>✓ Delivers timely, high-quality service you can trust</li> <li>✓ Provides team of unique experts to help you maximize instrument uptime</li> <li>✓ Ensure data integrity</li> <li>✓ Maintain operational stability</li> <li>✓ Reduce compliance risk</li> </ul> <p>www.hach.com/service-contracts</p>	<p><b>Pick&amp;Ship™</b></p> <p><i>Pick&amp;Ship™ Program offers a better way to keep your supplies in stock</i></p> <ul style="list-style-type: none"> <li>✓ <b>Convenience</b> of one purchase order for the entire year</li> <li>✓ <b>Flexibility</b> to change, cancel or create new orders</li> <li>✓ <b>Savings</b> from locking in prices &amp; thus avoiding price surges and rush charges</li> <li>✓ <b>Peace of mind</b> with automatic, reliable shipments just as you need them</li> </ul> <p>www.Hach.com/pickandship</p>	<p><b>Technical Support</b></p> <p><i>Provides post-sale instrumentation and application support</i></p> <ul style="list-style-type: none"> <li>✓ Hach's highly skilled Technical Support staff is dedicated to helping you resolve technical issues before, during and after the sale.</li> <li>✓ Available via phone, e-mail, or live online chat at Hach.com!</li> <li>✓ Fast access to answers at <a href="https://support.hach.com">https://support.hach.com</a></li> <li>✓ Toll-free phone: 800-227-4224</li> <li>✓ E-mail: techhelp@hach.com</li> </ul> <p>www.Hach.com</p>
--	--	--

**ADVANTAGES OF SIMPLIFIED SHIPPING AND HANDLING**

<p><b>Safe &amp; Fast Delivery</b></p> <ul style="list-style-type: none"> <li>✓ Receive tracking numbers on your order acknowledgement</li> <li>✓ Hach will assist with claims if an order is lost or damaged in shipment</li> </ul>	<p><b>Save Time – Less Hassle</b></p> <ul style="list-style-type: none"> <li>✓ No need to set up deliveries for orders or to schedule pickup</li> <li>✓ Hach ships order as product is available, at no additional charge, when simplified shipping and handling is used.</li> </ul>	<p><b>Save Money</b></p> <ul style="list-style-type: none"> <li>✓ No additional invoice to process – save on time and administrative costs</li> <li>✓ Only pay shipping once, even if multiple shipments are required</li> </ul>
--	--	--

STANDARD SIMPLIFIED SHIPPING AND HANDLING CHARGES <sup>1, 2, 3</sup>						Collect <sup>4</sup> Handling Fee Effective 8/31/19
Total Price of Merchandise Ordered	Standard Surface Delivery (Mainland USA)	Second Day Delivery (Mainland USA)	Next Day Delivery (Mainland USA)	Second Day Delivery (Alaska & Hawaii)	Next Day Delivery (Alaska & Hawaii)	
\$0.00 - \$49.99	\$11.99	\$29.99	\$55.93	\$48.14	\$91.51	\$8.98
\$50.00 - \$149.99	\$19.06	\$56.18	\$106.00	\$80.56	\$153.15	\$9.23
\$150.00 - \$349.99	\$33.48	\$89.32	\$181.94	\$112.71	\$219.36	\$9.81
\$350.00 - \$649.99	\$46.63	\$121.94	\$242.50	\$152.43	\$295.17	\$10.32
\$650.00 - \$949.99	\$58.77	\$127.42	\$266.65	\$157.77	\$297.40	\$10.69
\$950.00 - \$1,999.99	\$73.94	\$157.23	\$332.46	\$187.11	\$362.04	\$11.68
\$2,000.00 - \$3,999.99	\$85.36	\$167.09	\$342.29	\$194.36	\$369.69	\$13.48
\$4,000.00 - \$5,999.99	\$98.96	\$173.55	\$358.82	\$195.26	\$380.35	\$16.60
\$6,000.00 - \$7,999.99	\$116.93	\$197.60	\$408.56	\$215.38	\$415.24	\$19.36
\$8,000.00 - \$9,999.99	\$133.43	\$224.55	\$438.79	\$240.27	\$455.68	\$22.34
Over \$10,000	2% of Net Order Value	4% of Net Order Value	6% of Net Order Value	4% of Net Order Value	6% of Net Order Value	\$34.56

- Shipping & Handling charges shown are only applicable to orders billing and shipping to U.S. destinations. Shipping & Handling charges will be prepaid and added to invoice. Shipping & Handling for the Pick&Ship Program is charged on each shipment release and is based on the total price of each shipment release. Shipping & Handling charges are subject to change without notice.
- Additional Shipping & Handling charges will be applied to orders containing bulky and/or especially heavy orders. Refrigerated and all weather Samplers do not qualify for simplified Shipping & Handling charges, and are considered heavy products. Dissolved Oxygen Sensors can be damaged if exposed to temps below freezing, causing sensor failure. Must be shipped over night or 2nd day air during the cold weather months.
- Orders shipping to Alaska or Hawaii: Additional Shipping & Handling charges may be applied at time of order processing. Second Day and Next Day delivery is not available to all destinations.
- Hach Company will assess a collect handling fee on orders with collect shipping terms. This handling fee covers the additional costs that Hach Company incurs from processing and managing collect shipments.

**SALES TAX**

Sales Tax is not included in the attached quotation. Applicable sales and usage taxes will be added to your invoice, at the time of order, based on U.S. destination of goods, unless a valid resale/exemption certificate for destination state is provided to the above address or fax number, attention of the Tax Dept.



### Detail Bill of Material

Project Name:	City of Beaumont Salt Mitigation	Negotiation No:	LA280626X8K2
General Order No:	MLA0009343	Alternate No:	0011

Item No.	Qty	Product	Description
	1	Panelboards	42 Circuits, 100A, Fully Rated, 208Y/120V 3Ph 4W, Tin Plated Copper Bus, 22k AIC, 40A, 3P FD Main Breaker[Bottom Fed], Surface Mounted
		Catalog No	P1A100BB42TH4X
		Designation	LP-RW
	Qty	List of Materials	
	1	40A, 3P FD Main Breaker	
	17	20A, 1P QBHW Branch Breaker	
	1	30A, 1P QBHW Branch Breaker	
	24	1P QBHW Branch Provision Only	
	1	Tin-Plated Copper Main Bus, 100 Amps	
	1	Std. Bolted Cu Ground Bar (Cu Cable Only)	
	1	Panel Nameplate - White with Black Letters	
	1	Type 4X Enclosure, Stainless Steel: N4X2448N	

Total \$3,568.00

Eaton Selling Policy 25-000 applies.

All orders must be released for manufacture within 90 days of date of order entry. If approval drawings are required, drawings must be returned approved for release within 60 days of mailing. If drawings are not returned accordingly, and/or if shipment is delayed for any reason, the price of the order will increase by 1.0% per month or fraction thereof for the time the shipment is delayed.



Blank Cover  
4 inches

1	QBHW1030	QBHW1020	2
3	QBHW1020	QBHW1020	4
5	QBHW1020	QBHW1020	6
7	QBHW1020	QBHW1020	8
9	QBHW1020	QBHW1020	10
11	QBHW1020	QBHW1020	12
13	QBHW1020	QBHW1020	14
15	QBHW1020	QBHW1020	16
17	QBHW1020	QBHW1020	18
19	PROV	PROV	20
21	PROV	PROV	22
23	PROV	PROV	24
25	PROV	PROV	26
27	PROV	PROV	28
29	PROV	PROV	30
31	PROV	PROV	32
33	PROV	PROV	34
35	PROV	PROV	36
37	PROV	PROV	38
39	PROV	PROV	40
41	PROV	PROV	42

Main Breaker 40A  
FD3040, Vert Mtd.

General Information

(Section 1 of 1)

Service Voltage: 208Y/120V 3Ph 4W Enclosure: Type 4X  
 Bus Rating & Type: 100A Tin Plated Copper Neutral Rating: 100A  
 Ground Bar: Std. Bolted Copper, Cu cable only  
 S.C. Rating: 22k A.I.C. Fully Rated

Main Device Type: Main Breaker - Bottom Cable Entry  
 Main Terminals: Mechanical - (1) #14-1/0 (Cu/Al)  
 Neutral Terminals: Mechanical - (1) #14-1/0 (Cu/Al)  
 None: -  
 Box Catalog No.: N4X2448N  
 Trim: Complete Enclosure (WP2448T)

Surface Mounted

Box Dimensions: 48.00" [1219.2mm]H x 24.00" [609.6mm]W x 6" [152.4mm]D  
 Min. Gutter Size: Top = 5.5" [139.7mm] Bottom = 5.5" [139.7mm]  
 Left = 8.0" [203.2mm] Right = 8.0" [203.2mm]

Panel ID Nameplate: (1) LP-RW  
 Type: Plastic, adhesive-backed (2) 208Y/120V 3Ph 4W  
 Color: White with Black Letters (3)

UL \*\*\*Non-Interchangeable Main Device\*\*\*

Trim Lock: Padlockable Hasp  
 Circuit Directory: Plastic Sleeve with Card  
 Main Circuit Breaker Trip Type: Thermal-Magnetic.  
 Heat Loss - Watts (Est.) = 51  
 Weight - lbs (Est.) = 103

Device Modifications:  
Ref # Description

Branch Devices						
Qty	Poles	Trip	Frame	Amps	kAIC	
17	1	20	QBHW	100	22	
1	1	30	QBHW	100	22	
24	1		PROV			
Sub-Feed Devices						
Qty	Poles	Trip	Frame	Amps	kAIC	
2	0	N/A			22	
Main Devices						
Qty	Poles	Trip	Frame	Amps	kAIC	
1	3	40	FD	100	22	

Notes:

The information on this document is created by Eaton Corporation. It is disclosed in confidence and it is only to be used for the purpose in which it is supplied.

PREPARED BY TAP V PHAM	DATE 10/24/2019	Eaton	
APPROVED BY	DATE	JOB NAME City of Beaumont Salt Mitigation	DESIGNATION LP-RW
VERSION 1.0.0.30	TYPE	DRAWING TYPE Customer Approval	
NEG-ALT Number LA280626X8K2-0011	REVISION 0	DWG S A	ITEM MLA0009343
		314	SHEET 1 of 1



# PACIFIC STEEL GROUP

Contractor: WM Lyles

Date: 10/4/2019

Job Name: Salt Mitigation WWTP Upgrades

PSG Job #: L18161

Extra No.: 10

Description: Deduct Material and Labor for Clarification #006 for Chemical Storage #2.

Deduct Slab on Grade per contract drawings - -6,750 Lbs.

Add new walls and mechanical pads per drawing C2S-2 - 805 Lbs.

Please see attached correspondence.

Material:	Quantity:	Unit:	Unit Price:	Comments:	Extended Price:
Rebar	(5,945)	LB	\$ 0.60		\$ (3,567.00)
Specialty Rebar	-	LB	\$ 1.50		\$ -
Mesh	-	SQFT	\$ 0.35		\$ -
Couplers	-	Each	\$ 1.75		\$ -
Other	-	Each	\$ -		\$ -
					\$ (3,567.00)

Labor Impact:	Quantity:	Unit:	Unit Price:	Comments:	Extended Price:
Rebar	(20)	Hours	\$ 84.27		\$ (1,685.00)
Specialty Rebar	-	Hours	\$ 84.27		\$ -
Mesh	-	Hours	\$ 84.27		\$ -
Couplers	-	Hours	\$ 84.27		\$ -
Other	-	Hours	\$ 84.27		\$ -
					\$ (1,685.00)

FWA Labor:	Quantity:	Unit:	Unit Price:	Comments:	Extended Price:
Ironworker	-	Hours	\$ 84.27	Regular Base Pay	\$ -
Overtime	-	Hours	\$ 22.68	Premium Portion Only	\$ -
Doubletime	-	Hours	\$ 46.26	Premium Portion Only	\$ -
					\$ -

Other:	Quantity:	Unit:	Unit Price:	Comments:	Extended Price:
Engineering	-	Hours	\$ 70.00		\$ -
Crane	-	Hours	\$ 300.00		\$ -
Delivery	-	Each	\$ 550.00		\$ -
Other	-	Each	\$ -		\$ -
					\$ -

Sub Total = \$ (5,252.00)

Overhead & Profit @ 10% & 5% = \$ (814.00)

Sub Total = \$ (6,066.00)

Bond Fee = \$ (61.00)

Total Extra To Contract = \$ (6,127.00)



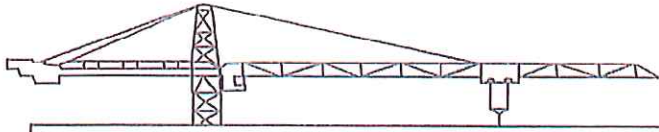

# ALLIED STEEL CO., INC.

*Structural Steel & Miscellaneous Metal Fabricators*



September 26, 2019

W.M. Lyles Company  
42142 Roick Dr.  
Temecula, CA 92590

Attn: Mr. Matt Cain, PE

Re: City of Beaumont

This letter will confirm our quote to furnish, fabricate, and deliver F.O.B. jobsite the galvanized steel framing and stainless steel hardware for the Mixer Support steel at the UV Disinfection Structure for the above referenced project.

Our quote for this material including required shop drawings is \$ 3,490.00

Please issue Allied Steel a change order if you wish for us to proceed with this extra work.

Sincerely,

A handwritten signature in blue ink, appearing to read "B. P. Chapman".

Brian P. Chapman  
President



Quote

Juan Ahumada  
 W.M. Lyles Company  
 42142 Roick Drive  
 Temecula, CA 92590  
 951-973-7393 ext  
[jahumada@wmlylesco.com](mailto:jahumada@wmlylesco.com)

Quote # DSN1183Q1

Dear Juan,

Thank you for the opportunity to provide the following quote. We quoted the tanks and all of the accessories per the specification noted. We also included pricing for the radar level control units.

**BEAUMONT WWTP SALT MITIGATION UPGRADE- TANKS**

Spec Section	Title and Description
<p><b>434143 Change Package #1</b></p>	<p><b>3 HIGH DENSITY CROSS-LINKED POLYETHYLENE STORAGE TANKS</b></p> <ul style="list-style-type: none"> <li>• (2) 1,150 Gallon (1) 4,600 Gallon Poly Processing Tanks</li> <li>• Safe Surge Manways</li> <li>• FRP Ladders</li> <li>• SST Seismic Restraints with CA Wet Stamped Job Specific Calculations</li> <li>• Float Level Indication</li> <li>• Fittings per specification</li> <li>• PTFE Flexi Joints</li> <li>• Material and Tank Testing</li> <li>• 3.2 B, C,D,E Field Service Technician one person one day included</li> <li>• Hastelloy for tank fittings only are Included on NaOCl Tank Drawing C-36 note 7</li> </ul> <p><b>No Exceptions taken to specification 434143 Part 1 through 3.1C and 3.2 B-E</b></p>
<p><b>434143 Package #2</b></p>	<p><b>2 HIGH DENSITY CROSS-LINKED POLYETHYLENE STORAGE TANKS</b></p> <ul style="list-style-type: none"> <li>• (2) 1,550 Gallon Poly Processing Tanks</li> <li>• Poly Wrap Insulation Panels</li> <li>• Heat Tracing</li> <li>• Safe Surge Manways</li> <li>• FRP Ladders</li> <li>• SST Seismic Restraints with CA Wet Stamped Job Specific Calculations</li> <li>• Float Level Indication</li> <li>• Fittings per specification</li> </ul>

	<ul style="list-style-type: none"> <li>• PTFE Flexi Joints</li> <li>• Material and Tank Testing</li> <li>• 3.2 B, C,D,E Field Service Technician one person one day included</li> <li>• Hastelloy for <u>tank fittings</u> only are included on NaOCl Tank Drawing C-36 note 7</li> </ul> <p><b>No Exceptions taken to specification 434143 Part 1 through 3.1C and 3.2 B-E</b></p>
<b>2.6 B Radar Level</b>	<p><b>Flowline</b> Echo Pulse LR20 Radar Liquid Level Transmitter with 316L Antenna and PTFE inner shield-</p> <p><b>No Exceptions to the spec</b></p>

**Pricing**

(3) Poly Processing Tanks and Accessories noted above <b>Package #1</b>	<b>FOB: Factory</b>	63,212
Tank Freight		8,000.
(2) Poly Processing Tanks and Accessories noted above <b>Package #2</b>	<b>FOB: Factory</b>	50,188
Tank Freight		5,200.
(5) Radar Units noted above \$2,590. Ea (Transmitter only)	<b>FOB: Factory</b>	12,950
Radar Freight		300.

**Notes & Exceptions**

Spec Section	Comment
3.2 A and 3.3	Field Testing and Installation by Others (1 day site inspection/ training is included)
General	Anchor bolts by others
General	Piping beyond vessel connections is not included
Standard Terms	25% with order / balance 70% N20 after shipment / 5% retention 90 days
Sales Tax	Sales tax will be billed at the rate in effect at the time of shipment and not included above
Disclosure	Items not specifically identified within proposal are not included

**Credits**

WM Lyles PO # 55.1173-4010 ( 2) 4,400 Gallon Safe Tanks and Accessories  
 Tax <4,028.45>  
 Freight <4,240.00>  
 Tanks <\$42,080>  
**Total Credit Amount.....\$50,348.45**

Thank you,

*Doug Roughen*

Doug Roughen | 3300 E. 19th Street | Signal Hill, CA 90755 | 562-986-5238 FAX 562-986-5246  
Cell 949-633-9499 Preferred

**2.0 Terms and Conditions**

Shipment	4-5 weeks
Manufacturer's Warranty	3 years and 5 years per specification
FOB Point	Poly Processing Factories
Prices Effective	30 days
Freight	Quoted as an option
Sales Tax	Not included unless otherwise indicated
Sales Tax	Will be charged unless a resale card is on file (CA & AZ)
Freight Billing	To be by purchaser specified at time of order placement
Terms	25% with order, balance net 20 days after shipment - OAC
Cancellation Charges	100% after fabrication commences
Damaged Freight	Must be noted on the freight bill to establish liability
Off-Loading / Installation	By others
Anchor Bolts	Not included unless otherwise indicated
Flange Gaskets / Bolt Kits	Not included unless otherwise indicated
Flexible Connections	Required for most connections to preserve tank warranty
Missing Parts	Claims must be made within 30 days of delivery



**Juan Ahumada**

---

**From:** Michael Hardy <mhardy@miscowater.com>  
**Sent:** Friday, August 30, 2019 1:25 PM  
**To:** Matt Cain  
**Subject:** beaumont mixer  
**Attachments:** EP-4164 Proposal.pdf

Matt

Mixer scope is attached. Price of the scope is \$19,100.

Mike

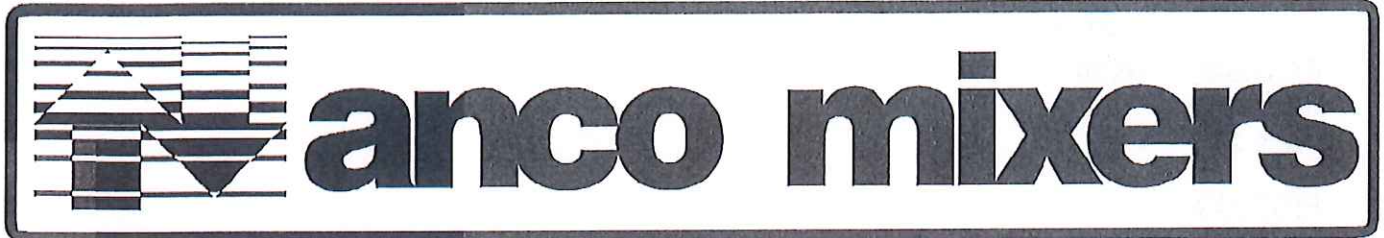

MANUFACTURED BY ENVIROPAX, INC. • SALT LAKE CITY, UTAH

## PROPOSAL

**TO: W. M. Lyles Co.**  
**42412 Roick Dr.**  
**Temecula, CA 92590**

**Attn: Matt Cain**

**Project Name:** Beaumont, CA WWTP

**Proposal Date:** 8/30/2019

**Proposal No:** EP-4164

**Bid Date:** Open

**Engineer:** Webb / Aqua Engineering

**Delivery:** 10-14 weeks

**Terms:** Net Thirty (30) days

---

We are pleased to offer the following equipment in accordance with the terms of this proposal

---

### SPECIFICATION SECTION 466250 – Vertical Shaft Turbine Mixer

A – One (1) ANCO MIXERS Model 3342E-7.5 heavy duty rapid mixer with 7 ½ HP, 1750 RPM, 460 volt, 3-phase, 60 cycle TEFC, severe duty, cast iron, motor rated for inverter duty. The mixer shall be furnished with a flat mounting base that is provided with a hot dipped galvanized coating. The mixer drive is a helical, parallel shaft gearbox, splash lubricated with a 3.2 service factor and a minimum AFBMA L<sub>10</sub> bearing life of 100,000 hours on the main gear reducer bearings and 300,000 hours on the output bearings. The reducer input shaft is driven by a flexible coupling and the output shaft is equipped with a rigid, register fit flanged coupling to maintain impeller shaft alignment. The impeller shaft is designed to operate at less than 70% of the first critical speed and combined shaft stress is less than 8,000 psi. The shaft rotates at 96.3 RPM. The impeller is a 29" diameter, 6-blade radial flow disc type with the blades welded to the impeller hub disc. The impeller position is non-adjustable and is driven by a safety hook key. The shaft and impeller material is 316 SS.

Beaumont, CA WWTP  
Proposal EP-4164  
8/30/2019  
Page 2

PRICING

The prices quoted are FOB factory with freight allowed to the jobsite and includes only those items detailed above and in accordance with the terms and conditions noted in the proposal:

ITEM A Rapid Mixer ..... \$\_\_\_\_\_

ITEMS NOT INCLUDED

The following have not been included unless specifically called out above:

- Variable frequency drives and controls
- Electrical motor controls, starters, or wiring
- Anchor bolts or imbedments
- Support beams, walkways
- Anti-vortex baffling
- Unloading, hauling or storage
- Erection, installation or testing
- Concrete, grouting or sealant
- Field paint or touch-up painting
- Protection against rusting or deterioration due to unprotected storage
- Service to include supervision of erection, installation, inspection or start-up
- Federal, State or Local Taxes, Permits or Fees

SERVICE

One (1) day and one (1) trip service of a factory representative has been included in the above pricing for inspection, supervision or start-up assistance. Additional service is available at a rate of \$1,000.00 per day plus travel and living expenses from Salt Lake City, Utah.

SHIPMENT

Estimated shipment time is 10-14 weeks after receipt of final complete approved submittal drawings, if required. Drawing submittal is estimated to be 2-3 weeks after receipt of purchase order and complete engineering information.

TERMS AND CONDITIONS

Prices are firm for a period of sixty (60) days from proposal date. Invoices are due and payable within thirty (30) days of any deliveries made to the jobsite and in accordance with the standard terms and conditions attached.



Beaumont, CA WWTP  
Proposal EP-4164  
8/30/2019  
Page 3

For pricing and additional information, please contact our local representative at the following address:

**MISCOWater**  
17101 Burbank Suite B  
Foothill Ranch, CA 92610  
Mike Hardy  
Office: 949-458-5555  
Fax: 949-458-5500

Respectfully submitted,

ENVIROPAX, INC.

Brett Lees



## GENERAL TERMS AND CONDITIONS

1. **Scope:** Enviropax, Inc.'s acceptance of Purchaser's purchase order is conditioned upon the following:
  - (a) All the terms and conditions set forth herein;
  - (b) Return to Enviropax, Inc. a signed copy of this proposal with Purchaser's purchase order;
  - (c) A copy of any payment and performance bond on this project setting out name and address of Bonding Company and Local Agency being forwarded to Enviropax, Inc.;
  - (d) Acceptance in writing of Purchase Order by Enviropax.
  
2. **Prices:** Prices are quoted F.O.B. factory with a freight allowance only, unless specifically noted on the proposal. Prices do not include Federal, State or Local taxes of any whatsoever. Applicable taxes will be added to the quoted price unless a valid exemption certificate has been provided to Enviropax, Inc. Quoted prices are subject to change prior to acceptance of purchase order by Enviropax.
  
3. **Payment and Credit:** Terms of Payment are Net 30 days from invoicing. All past due amounts shall accrue interest at the rate of 2% per month until paid in full. Purchaser shall be responsible to pay all costs of collection, including reasonable attorneys fees, whether or not a lawsuit is filed. If it should become necessary to file legal action for collection or interpretation of the terms of this agreement, parties hereby agree that venue of such action is proper in the County District Courts in and for the County of Salt Lake, Utah. All orders are subject to the continuing approval of Enviropax Credit department. If Purchaser is in default on any payment due hereunder, Seller may declare all payments for work completed to be immediately due and payable, stop all further work until payments are brought current and require advance payment for future shipments under this agreement.
  
4. **Items Included:** Each sale includes only those items specifically described and set forth in this proposal. This agreement cannot be amended or modified except by written agreement of the parties.
  
5. **Security Interest:** Enviropax retains a security interest in and the rights of repossession of the equipment furnished hereunder until the full purchase price has been paid. Purchaser will not encumber nor permit others to encumber said equipment by any liens or security instruments, until Enviropax has been paid in full. In the event of any default under this agreement, Enviropax shall be entitled to exercise any and all legal remedies granted to it under applicable law.
  
6. **Shipments and Delivery:** Enviropax shall use reasonable efforts to meet specified delivery dates, but such dates are estimated only and are not guaranteed and Enviropax shall have no liability, directly or indirectly for delays in delivery. Enviropax may not be declared in breach of contract or shall the order be subject to cancellation so long as Enviropax is making a bona fide effort to complete the manufacture and delivery of the equipment. Delivery times are based upon the effective date of the order and subject to prompt receipt by Enviropax of all necessary information, instructions and approved shop drawings from purchaser. Shipments shall be by surface freight.
  
7. **Risk of Loss:** All shipments are F.O.B. Enviropax factory and all claims for damage, delay or shortage arising from any shipment shall be made directly with the carrier by the purchaser. Purchaser shall inspect the equipment, and shall notify Enviropax of any damage or shortage within one week of delivery. Failure to so notify Enviropax shall constitute acceptance by purchaser and release of Enviropax of any liability for damage or shortage.
  
8. **Limited Warranty:** Enviropax warrants all products manufactured by it against defects in materials and workmanship for a period of one year from delivery. If a defect exists, Enviropax shall, at its option, either repair or replace the defective item at a location to be designated by Enviropax or repay the purchase price of any defective item, provided it receives prompt written notice of the defect claimed, but in no event shall notice be received later than thirty (30) days after the end of the one-year warranty period. This warranty shall not apply to any products altered or repaired outside Enviropax's factory or with other than Enviropax



replacement parts, unless such repair was authorized in writing by Enviropax and further, shall not apply to products or parts which have been subject to misuse, abuse, neglect or accident or damage by improper installation or application by others. In no event shall Enviropax be liable for normal wear and tear, nor for any incidental or consequential damages due to the inoperability of its products. THE FOREGOING IS IN LIEU OF ALL OTHER WARRANTIES, EXPRESSED OR IMPLIED, INCLUDING, BUT NOT LIMITED TO, THE WARRANTIES OF MERCHANTABILITY AND FITNESS FOR A PARTICULAR PURPOSE.

9. **Cancellation, Suspension or Delay:** If purchaser requests or causes a cancellation, suspension or delay, Purchaser shall pay Enviropax all appropriate charges incurred up to the date of such cancellation, suspension or delay, plus Enviropax overhead and reasonable profit. Additionally, all charges related to and risks incident to, storage, deposition, and/or resumption of work shall be born solely by Purchaser.
10. **Limitation of Liability:** Enviropax shall not be liable to purchaser or anyone claiming through Purchaser for any incidental or consequential damages of any nature for any reason whatsoever. Responsibility for proper operation of equipment if not installed by Enviropax or in accordance with Enviropax's instructions, shall rest entirely with Purchaser. Enviropax shall not be responsible for compliance with State or local safety and/or health statutes unless it has accepted such responsibility in writing. Any cost of compliance shall be born by Purchaser.
11. **Changes, Orders and Backcharges:** Enviropax shall not be obligated to make changes in or additions to the scope of the work or the equipment furnished unless prior to such changes or additions, Enviropax receives a written change order setting forth the additions or changes desired, the adjustments in the contract price and time of delivery, all of which must be accepted by Enviropax in writing. Enviropax will not be responsible or liable for returns or backcharges for labor, materials or other costs incurred in modification, adjustment, service or repair of equipment unless previously approved in writing by an authorized agent of Enviropax.
12. **Changes in Design:** Enviropax reserves the right to modify the design and construction of equipment in order to incorporate improvements or to substitute material equal or superior to that originally specified. No charge shall be made to Purchaser for modifications made at Enviropax's option.
13. This contract is a complete integration of the agreements of the parties and supercedes all prior oral or written agreements of any nature, and may not be modified except in writing signed by both parties. This contract shall be binding upon and shall insure to the benefit of the parties hereto and their successors and assigns.



WM Lyles  
Attn: Juan Ahumada  
Re: Leak Detection System – clarification 16

Juan,

Here is the pricing

Leak Detection system probes and Panel

2ea	Leak Detection Probes	\$1999	\$3,998
1ea	Leak detection control station	\$5500	\$5,500

Please issue PO to JPR Systems

Thank you

John Hamilton  
909-660-1022  
John.hamilton@jprsystems.com



W M Lyles  
 Juan Ahumada  
 Re: PO 55.1173 revisions

Juan,

Here are the revisions:

Sodium Hypo Skid	(\$17,365)
Panel	\$1,500
Engineering	\$1,500
Total Credit:	(\$14,365)

Additions

2 ea Pump skids (Sodium bisulfate/Caustic)	\$31,730
Chem Skid Covers with FRP plate (2ea)	\$16,596
Heat Trace System all components(3 areas)	\$10,554
Panel Mount cover for chlorine SCE	\$1,680

Thank you

John Hamilton  
 909-660-1022  
 John.hamilton@jprsystems.com





# Raychem XTV

## HIGH-TEMPERATURE SELF-REGULATING HEATING CABLES



Electrical freeze protection and process-temperature maintenance for both nonhazardous and hazardous locations

### Heating cable construction

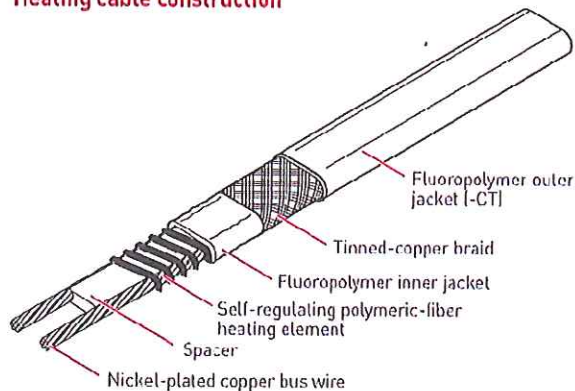

### PRODUCT OVERVIEW

The XTV family of self-regulating heating cables provides solutions for industrial freeze protection and process-temperature maintenance applications requiring high power output. XTV heating cables can withstand temperatures up to 482°F (250°C) and provide process temperature maintenance to 250°F (121°C).

The heating cables are configured for use in nonhazardous and hazardous locations, including areas where corrosives may be present.

The power output of self-regulating heating cable depends on the heating cable temperature, and can provide up to 20 W/ft at 50°F (10°C).

Raychem XTV cables meet the requirements of the U.S. National Electrical Code and the Canadian Electrical Code. For additional information, contact your Pentair Thermal Management representative or call (800) 545-6258.

### APPLICATION

Area classification	Nonhazardous and hazardous locations
Traced surface type	Metal
Chemical resistance	Organic and aqueous inorganic chemicals and corrosives

### SUPPLY VOLTAGE

XTV1	100–130 Vac
XTV2	200–277 Vac

### TEMPERATURE RATING

Maximum maintain or continuous exposure temperature (power on)	250°F (121°C)
Maximum intermittent exposure temperature, 1000 hours (power on or off)	482°F (250°C)*
Minimum installation temperature	-40°F (-40°C)

\*The 250°C rating applies to all products printed "MAX INTERMITTENT EXPOSURE 250C"

### TEMPERATURE ID NUMBER (T-RATING)

<b>T2C:</b> 446°F (230°C)	<b>T2D:</b> 419°F (215°C)	<b>T3:</b> 392°F (200°C)
Temperature ID numbers are consistent with North America National Electrical Codes.		
20XTV2-CT-T2 20XTV1-CT-T2	15XTV1-CT-T2	5XTV1-CT-T3, 5XTV2-CT-T3, 10XTV1-CT-T3, 10XTV2-CT-T3 15XTV2-CT-T3

Based on systems approach\* T3-T6

\* Raychem XTV heating cables are approved for T3 – T6 temperature classes when utilized on controlled designs are used according to the requirements of applicable national and international approvals standards. Use TraceCalc Pro design software. Pentair Thermal Management.

XTV

**APPROVALS**

**IECEX** IECEx BAS 06.0044X  
Ex e IIC T\* Gb  
Ex tD A21 IP66 T\*\*+30C

**Hazardous Locations**



Class I, Div. 2, Groups A, B, C, D  
Class II<sup>(1)</sup>, Div. 2, Groups F, G  
Class III<sup>(1)</sup>



Class I, Div. 1 and 2, Groups A, B, C, D  
Class II, Div. 1 and 2, Groups E, F, G  
Class III

XTV heating cables also have many other approvals, including Baseefa, PTB, DNV, and ABS.

**Zone Approvals**



CL I, ZNI, AEx e II T3 (T2)



Ex e II T3 (T2)



09-IEEx-0005X  
Ex e IIC T\* Gb

<sup>(1)</sup> Applications must be reviewed by the manufacturer.  
<sup>(2)</sup> For maximum surface temperature, see heating cable, design documentation or schedule

**DESIGN AND INSTALLATION**

For proper design and installation, use TraceCalc Pro design software or the design section of the Advanced Industrial Solutions Heat-Tracing Products & Services Catalog (H56550). Also, refer to the Industrial Heat-Tracing Installation and Maintenance Manual (H57274). Literature is available via the Pentair Thermal Management web site, [www.pentairthermal.com](http://www.pentairthermal.com).

**NOMINAL POWER OUTPUT RATING ON METAL PIPES AT 120 V / 240 V**

	Adjustment factors	
	Power output	Circuit length
<b>208 V</b>		
5XTV2	0.87	0.99
10XTV2	0.88	0.99
15XTV2	0.88	0.98
20XTV2	0.86	1.00
<b>277 V</b>		
5XTV2	1.07	1.08
10XTV2	1.08	1.06
15XTV2	1.08	1.06
20XTV2	1.07	1.08

- Ⓐ 20XTV-CT
- Ⓑ 15XTV-CT
- Ⓒ 10XTV-CT
- Ⓓ 5XTV-CT

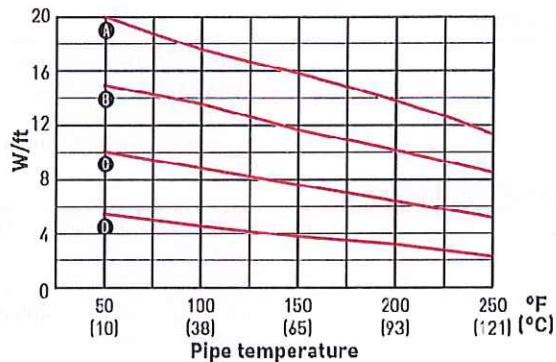

**Note:** To choose the correct heating cable for your application, use the Design section of the Advanced Industrial Solutions Heat-Tracing Products & Services Catalog (H56550). For more detailed information, use TraceCalc Pro design software.

**MAXIMUM CIRCUIT LENGTHS BASED ON CIRCUIT BREAKER SIZES**

	Ambient temperature at start-up	Maximum circuit length (in feet) per circuit breaker									
		120 V					240 V				
		15 A	20 A	30 A	40 A	50 A	15 A	20 A	30 A	40 A	50 A
5XTV-CT	50°F (10°C)	180	240	360	385	385	360	480	720	765	765
	0°F (-18°C)	160	210	320	385	385	315	420	625	765	765
	-20°F (-29°C)	150	200	305	385	385	295	395	595	765	765
	-40°F (-40°C)	145	195	290	385	385	285	380	570	760	765
10XTV-CT	50°F (10°C)	110	145	220	270	270	220	295	440	540	540
	0°F (-18°C)	95	130	195	260	270	195	260	385	515	540
	-20°F (-29°C)	95	125	190	250	270	185	245	370	495	540
	-40°F (-40°C)	90	120	180	240	270	175	235	355	470	540
15XTV-CT	50°F (10°C)	75	100	150	200	220	150	200	300	400	445
	0°F (-18°C)	65	90	135	180	220	130	175	265	355	440
	-20°F (-29°C)	65	85	130	170	215	125	165	250	335	420
	-40°F (-40°C)	60	80	125	165	205	120	160	240	320	405
20XTV-CT	50°F (10°C)	60	80	120	160	190	115	150	230	305	380
	0°F (-18°C)	50	70	105	140	180	100	135	205	275	345
	-20°F (-29°C)	50	65	100	135	170	100	130	200	265	330
	-40°F (-40°C)	50	65	100	130	165	95	125	190	255	320



**PRODUCT CHARACTERISTICS**

Minimum bend radius	@68°F (20°C): 0.5 in (12.7 mm)
Weight (lb per 10 ft, nominal)	1.1
Bus wire size	14 AWG
Outer jacket color	Red
Heating cable dimensions	0.46 in x 0.3 in (11.7 mm x 7.6 mm)

**ORDERING DETAILS**

DESCRIPTION	PART NUMBER
5XTV1-CT-T3	P000001668
5XTV2-CT-T3	P000001669
10XTV1-CT-T3	P000001671
10XTV2-CT-T3	P000001672
15XTV1-CT-T2	P000001674
15XTV2-CT-T3	P000001675
20XTV1-CT-T2	P000001676
20XTV2-CT-T2	P000001677

**CONNECTION KITS**

Pentair Thermal Management offers a full range of connection kits for power connections, splices, and end seals. These connection kits must be used to ensure proper functioning of the product and compliance with warranty, code, and approvals requirements.

**GROUND-FAULT PROTECTION**

To minimize the danger of fire from sustained electrical arcing if the heating cable is damaged or improperly installed, and to comply with the requirements of Pentair Thermal Management, agency certifications, and national electrical codes, ground-fault equipment protection must be used on each heating cable branch circuit. Arcing may not be stopped by conventional circuit protection. Many Raychem control and monitoring systems meet the ground-fault protection requirement.



WWW.PENTAIRTHERMAL.COM

**NORTH AMERICA**

Tel: +1.800.545.6258  
Fax: +1.800.527.5703  
Tel: +1.650.216.1526  
Fax: +1.650.474.7711  
thermal.info@pentair.com

**EUROPE, MIDDLE EAST, AFRICA**

Tel: +32.16.213.511  
Fax: +32.16.213.603  
lthermal.info@pentair.com

**ASIA PACIFIC**

Tel: +86.21.2412.1688  
Fax: +86.21.5426.2937  
cn.thermal.info@pentair.com

**LATIN AMERICA**

Tel: +1.713.868.4800  
Fax: +1.713.868.2333  
thermal.info@pentair.com

Pentair, XTV and TraceCalc Pro are owned by Pentair or its global affiliates. All other trademarks are the property of their respective owners. Pentair reserves the right to change specifications without prior notice.

© 1996–2014 Pentair.



## DigiTrace RTD4AL RTD TEMPERATURE SENSOR

For temperature measurement up to 900°F (482°C)

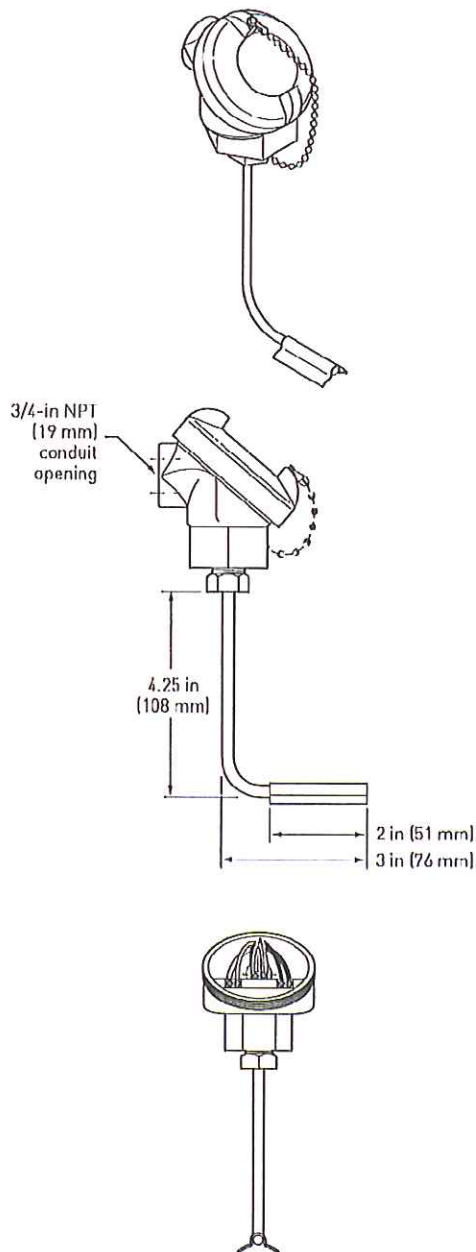

### PRODUCT OVERVIEW

The DigiTrace RTD4AL is a three-wire platinum RTD (resistance-temperature detector) typically used with monitoring and control systems that require accurate temperature control. The RTD4AL kit can be used with a wide variety of DigiTrace monitoring and control systems.

### SPECIFICATIONS

Sensor housing	Aluminum; NEMA 4X
Sensor sheath	316 stainless steel
Range	-100°F to 900°F (-73°C to 482°C) maximum
Accuracy	±1°F (0.5°C) at 32°F (0°C)
Resistance	100 ohms at 0°C $\alpha = 0.00385$ ohms/ohm/°C
Connection	3/4-in (19 mm) NPT conduit hub <b>Note:</b> The length of RTD extension wires is determined by the wire gauge used. To reduce the likelihood that electrical noise will affect temperature measurement, keep RTD extension wires as short as possible. Use shielded instrument cable such as DigiTrace MONI-RTD-WIRE (22 AWG, PVC insulation, -30°F to 140°F, -20°C to 60°C) or Belden 83553 (22 AWG, FEP insulation, -95°F to 395°F, -70°C to 200°C).

### ADDITIONAL MATERIALS REQUIRED

Pipe strap, conduit, 16-22 AWG shielded instrument cable

### KIT CONTENTS

One RTD temperature sensor

### APPROVALS

The RTD4AL is CSA certified to U.S. and Canadian standards.

 Class I, Div. 2, Groups A, B, C, D  
Class II, Div. 2, Groups F, G



WWW.PENTAIRTHERMAL.COM

**NORTH AMERICA**

Tel: +1.800.545.6258  
Fax: +1.800.527.5703  
Tel: +1.650.216.1526  
Fax: +1.650.474.7711  
thermal.info@pentair.com

**EUROPE, MIDDLE EAST, AFRICA**

Tel: +32.16.213.511  
Fax: +32.16.213.603  
thermal.info@pentair.com

**ASIA PACIFIC**

Tel: +86.21.2412.1688  
Fax: +86.21.5426.2917  
cn.thermal.info@pentair.com

**LATIN AMERICA**

Tel: +1.713.868.4800  
Fax: +1.713.868.2333  
thermal.info@pentair.com

Pentair and DigiTrace are owned by Pentair or its global affiliates. All other trademarks are the property of their respective owners. Pentair reserves the right to change specifications without prior notice.

© 2001–2013 Pentair.





# Raychem E-100-A AND E-100-L-A END SEAL AND LIGHTED END SEAL KITS

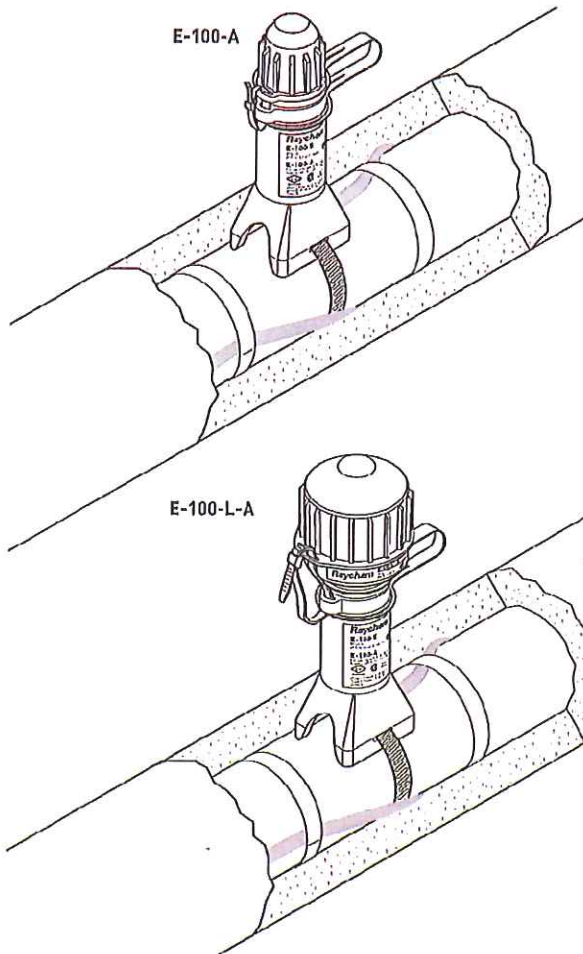

### PRODUCT OVERVIEW

The E-100-A and E-100-L-A serve as above-insulation end seal kits for Raychem brand BTV, QTVR, XTV, KTV, or VPL heating cables. They are approved by FM and CSA for use in hazardous locations.

Both the E-100-A and the E-100-L-A are mounted on the pipe and project through the thermal insulation and cladding for ease of maintenance. The E-100-L-A end seal with signal light uses an array of bright LEDs for exceptional visibility and long product life.

These rugged end seals are made from high-performance engineering polymer and resist impact, high temperature, and chemical and UV exposure. The stand allows for up to four inches (100 mm) of thermal insulation. The encapsulated light and boot reliably prevent moisture and dust ingress. The industrial-grade electronics used in the E-100-L-A are encapsulated.

Both the E-100-A and E-100-L-A are re-enterable, allowing easy access for testing. Voltage and continuity checks can be done by simply unscrewing the E-100-A cap and removing the reusable sealing boot. The E-100-L-A makes maintenance even easier by allowing for visual inspection of heating circuit continuity. The E-100-L-A is available in two voltages and can be retrofitted into previously installed E-100-A end seals. The light module is replaceable.

The kits contain all the necessary materials for a complete installation except for one pipe strap, which must be ordered separately.

	E-100-A	E-100-L-A
<b>DESCRIPTION</b>	Above-insulation end seal, cold-applied	Above-insulation end seal with red signal light, cold-applied *Not for use with 480 VVPL
<b>KIT CONTENTS</b>	1 end seal	1 end seal with red indicator light
<b>Note:</b> Order appropriate pipe strap separately (one per kit)		

## E-100-A AND E-100-L-A

## E-100-A

## E-100-L-A

## APPROVALS

## Hazardous Locations



Class I, Div. 2, Groups A, B, C, D  
Class II, Div. 1 and 2, Groups E, F, G  
Class III



CL1, ZN1, AEx e II T<sup>(2)</sup>



Ex e II T<sup>(2)</sup>



IECEx PTB 09.0038U  
Ex e II Ex tD A21 IP66



09-IEx-0004X  
Ex e IIC T<sup>\*</sup> Gb

(II) Except VPL

(2) For T-rating, see heating cable or design documentation

## Hazardous Locations



Class I, Div. 2, Groups A, B, C, D  
Class II, Div. 1 and 2, Groups E, F, G  
Class III



CL1, ZN1, AEx em II T<sup>(2)</sup>



Ex em II T<sup>(2)</sup>



IECEx PTB 09.0038U  
Ex emb II  
Ex tD mbD A21 IP66



09-IEx-0004X  
Ex e IIC T<sup>\*</sup> Gb

## E-100-A

## E-100-L-A

## PRODUCT SPECIFICATIONS

Heating cable capability	BTV-CR, BTV-CT, QTVR-CT, XTV-CT, KTV-CT and VPL-CT	
Ingress protection	NEMA 4X (IP65)	NEMA 4X (IP65)
Minimum installation temperature	-40°F (-40°C)	-40°F (-40°C)
Minimum ambient temperature	-75°F (-60°C)	-40°F (-40°C)
Maximum ambient temperature	132°F (56°C)	104°F (40°C)
Maximum pipe temperature	500°F (260°C)	500°F (260°C)
Maximum operating voltage	480 Vac	120 / 277 Vac
Overall height	7 in (175 mm)	8 in (200 mm)
Outer diameter at insulation	2.0 in (50 mm) Usable with up to 4 in (100 mm) thermal insulation	3 in (75 mm)
Materials	High-performance glass-filled engineered polymer	High-performance glass-filled engineered polymer
Light source		Super-bright light-emitting diodes (LEDs), red
Light source power supply	Not applicable	Linear (nonswitching)
Power consumption	0 W	< 2 W

E-100-A AND E-100-L-A

	E-100-A	E-100-L-A	
<b>ORDERING DETAILS</b>			
<b>End seal</b>			
Catalog number	E-100-A (100-480 Vac)	E-100-L1-A (100-120 Vac)	E-100-L2-A (200-277 Vac)
Part number	046567-000	583377-000	478767-000
Weight	0.6 lb (272 g)	1.3 lb (630 g)	1.3 lb (630 g)

**Spare boot pack for E-100**

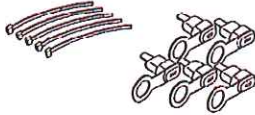

Catalog number	E-100-BOOT-5-PACK
Part number	281053-000
Pack weight	0.25 lb (140 g)
Pack contents	Five sealant-filled boots and five cable ties

**Replacement indicator light for E-100-LXX-A**

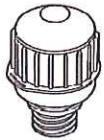

Catalog number	E-100-LR1-A (100-120 Vac)	E-100-LR2-A (200-277 Vac)
Part number	552225-000	874485-000
Weight	0.9 lb (450 g)	0.9 lb (450 g)





WWW.PENTAIRTHERMAL.COM

**NORTH AMERICA**

Tel: +1.800.545.6258  
Fax: +1.800.527.5703  
Tel: +1.650.216.1526  
Fax: +1.650.474.7711  
thermal.info@pentair.com

**EUROPE, MIDDLE EAST, AFRICA**

Tel: +32.16.213.511  
Fax: +32.16.213.603  
thermal.info@pentair.com

**ASIA PACIFIC**

Tel: +86.21.2412.1688  
Fax: +86.21.5426.2917  
cn.thermal.info@pentair.com

**LATIN AMERICA**

Tel: +1.713.868.4800  
Fax: +1.713.868.2333  
thermal.info@pentair.com

Pentair, BTV, QTVR, XTV, KTV, and VPL are owned by Pentair or its global affiliates. All other trademarks are the property of their respective owners. Pentair reserves the right to change specifications without prior notice..

© 2001-2013 Pentair.



# **Raychem** 910 Series Heat Trace Controller

## INSTALLATION, OPERATING AND MAINTENANCE INSTRUCTIONS

Firmware versions up to V3.1x

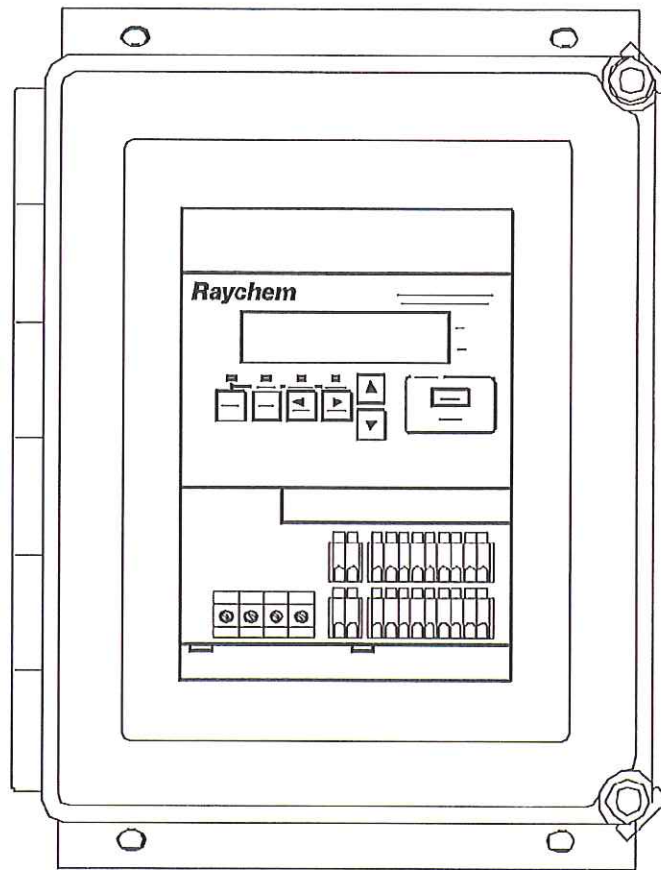

In the event of a late price revision, only cover pages will be sent. Refer to the preceding revisions for details.

<p><b>Denny McCollum, 951-505-2634, <a href="mailto:denny@cortecheng.com">denny@cortecheng.com</a>;</b>  <b>Greg Scott – <a href="mailto:greg.scott@cortecheng.com">greg.scott@cortecheng.com</a></b>  1340 N. Jefferson Street, Anaheim CA 92807  Phone (714) 779-0911 · Fax (714) 693-1715  <a href="http://www.cortecheng.com">www.cortecheng.com</a></p>	<p><b>Attention:</b> WM Lyles  <b>Project:</b> City of Beaumont – Salt Mitigation Upgrade Project  <b>Subject:</b> Sample Pump Proposal  <b>Date:</b> September 3, 2019</p>
--	---



*Scope of supply is based on plans, specifications and addenda for the aforementioned project. Please note that service or materials not specifically listed as included in this proposal will not be supplied. Taxes are NOT included. FOB: Destination (Beaumont, CA). Standard Freight is Included.*

**Section 463344– Peristaltic Metering Pump .....\$7,782.00**

**Equipment Description:**

Chlorine Sample Pump, Tags P-7471

- (Qty. 1) Verderflex Rapide R12 peristaltic metering pump with 5/8" x 3/16" tube, 1/4 HP @ 173 RPM, 3/60/230/460 VAC, IP55 Enclosure.

**Factory/Field Services:**

- Non-witnessed standard factory testing
- Field testing, startup & training per spec

**Lead Times:**

- Submittals: 1-2 weeks after receipt of formal purchase order
- Shipment: 3-4 weeks after approval of submittals & release to manufacturer

**Comments/Exceptions:**

- Spare parts requests a stack kit. A stack kit is for vertical multistage pumps and does not apply to the Verderflex pump. (Qty 5) replacement tubes will be provided as standard spare parts.

**General Comments/Exceptions (Applicable to all sections unless specifically noted in sections above):**

No discharge pipe, installation, offloading, onsite vibration monitoring, anchor bolts/nuts, instrumentation, piping, safety equipment, tools, VFDs/PLCs/MCCs, hardware etc., nor any items not specifically listed as included. Labor and installation by contractor. Startup is limited to verifying functionality and/or equipment calibration only. Extended-length operational tests are by others. Neither liquidated damages nor consequential damages of any type are accepted. Quote is valid for sixty (60) calendar days.

Best regards,

Greg Scott  
Projects Team Manager  
Cortech Engineering, LLC – A DXP Company  
1340 N. Jefferson St., Anaheim, CA 92807  
Phone: 714.779.0911 ext.1358  
Cell: 714.293.4789  
[greg.scott@cortecheng.com](mailto:greg.scott@cortecheng.com)

# Verderflex Rapide R12

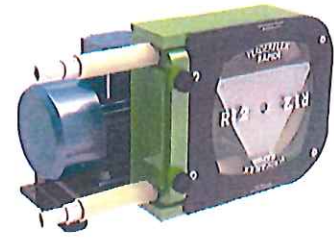

**VERDERFLEX**<sup>®</sup>

## Verderflex Rapide R12 Specifications

Standard Speeds	115 & 173 RPM
Control	Inverter Optional
Rotor Assembly	Anodised Aluminium with Three Nylatron <sup>®</sup> Rollers
Voltage	265/460V 60Hz (Single Phase Available to special order)
Installed Motor Power	¼ HP 60Hz
Protection Class	IP55
Standard Tube Options	Verderprene, Silicone
Tube Size	5/8" x 3/16" (15.9 x 4.8 mm)
Weight	26.5 lbs

## Flow Rates

Tube	RPM	Flow GPH	Flow GPM	Flow ml/min	Flow l/h
5/8" x 3/16"	115	182	3.03	11.470	688.2
5/8" x 3/16"	173	273	4.56	17.260	1035.6

*\*actual speed and flow rates may vary depending on motor speeds, the medium being pumped and the actual application setup*

Nominal pump speed based on 60Hz operation

Flows are typical and were measured with water at 68°F with no suction lift or discharge pressure. Actual flows will vary according to suction conditions, discharge pressure, tube material and production tolerances.





# Verderflex Rapide R12

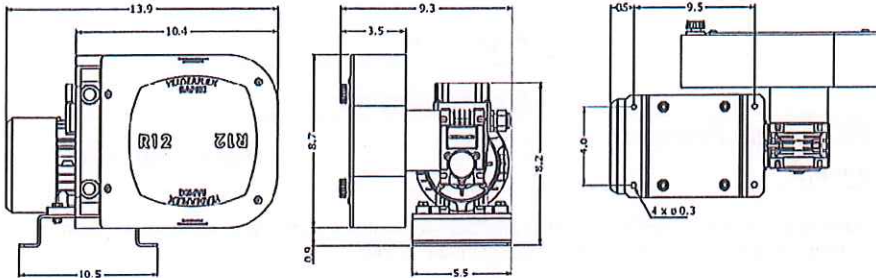
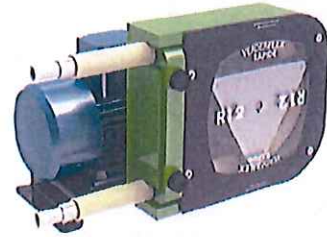

All dimensions are in inches.  
All dimensions and weights are for guidance only.

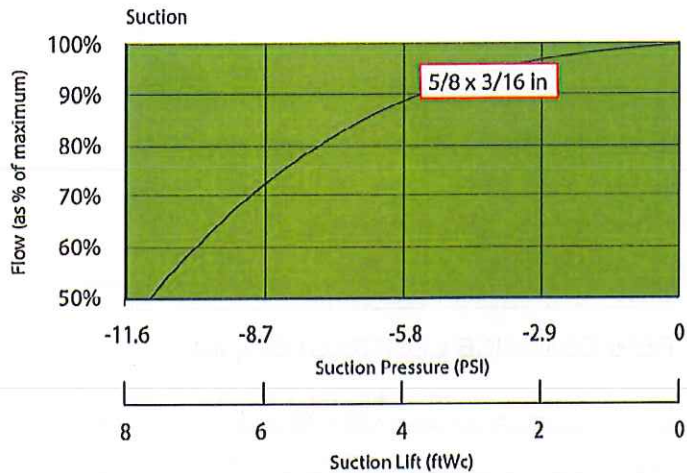
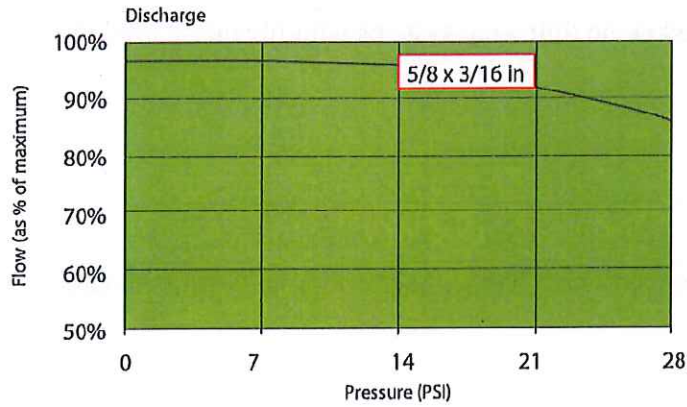

VF\_Techno\_Rev06\_2019\_(us)\_Rapide

Find your local supplier  
at [www.verderflex.com](http://www.verderflex.com)



1270 Hancock Street  
Anaheim, CA. 92897  
Phone: (714) 701-9141  
Fax: (714) 701-0168

# PROPOSAL INSULATION SERVICES DIVISION

To: <b>WM Lyles</b> <b>Attn: Matt Cain</b>	Date: <b>September 6<sup>th</sup>, 2019</b>
	Page One
	Architect/Engineer:
Job Name <b>Beaumont WWTP Caustic Piping</b> <b>Insulation Extra work</b>	Location <b>Beaumont, CA</b>

Performance Contracting, Inc. (hereinafter designated as "CONTRACTOR") proposes to furnish all materials and labor required for the application of the following (hereinafter designated as the "Work") for the amount stated below:

## Insulation & Jacketing Proposal

Supply labor and material to insulate and jacket the following systems with fiberglass insulation:

### I. Caustic Piping

Our lump sum cost to complete the above-mentioned work is eight thousand three hundred sixty-one dollars (\$8,361.00)

- Price **includes** Sales Tax.
- Price does not include furnishing of bonds. If bonds are required, add 1% to the base price.

In the event CONTRACTOR's price is included within your bid, then CONTRACTOR's bid will be deemed to have been accepted.  
This proposal is subject to change and will be withdrawn if not accepted within 30 days of the above date; It is subject to and includes all terms and conditions described herein (and such other terms as may be mutually agreed upon).

Contract Price \$ <b>See above</b>	PERFORMANCE CONTRACTING, INC.
Acceptance Date: _____	By: <b>Nicholas Naretta</b>
By: _____	Title: <b>Project Engineer</b>
Customer Name: _____	By: _____
Title: _____	Approval Date: _____





# MFG CONSTRUCTION & WATER PRODUCTS

Date: August 29, 2019

To: Misco  
Reference: Beaumont Baffles  
Attn: Mike

Fax #:  
Phone #:

**MFG IS QUOTING:**

Two (2) FRP baffles consisting of the following: 1 baffle 3' high x 8' long, 1 baffle 4' high x 7' long, FRP wall angles, 1/2x4-1/2 anchors and 1/2x2 HHMB. All h/ware to be type 316 SS.

**Price is: \$5780.00 Delivered**

**NOTE: If any calculations are required for this project add \$4000.00 to the price above.**

NOTE: The price quoted does not provide for a payment retainer and is for material only. This quote does not include any operating or mechanical equipment and does not require any site services.

NOTE: MATERIAL QUOTED ISOPHTHALIC POLYESTER RESIN

EXCLUSIONS: 1) Taxes; 2) Installation; 3) Painting/Coating; 4) Field Measurements; 5) Any item not specifically included above; 6) Field service & Start-up certification

*Terms: Net 30 days with no retainer*

*Price good for 90 days*

MFG Construction & Water Products

Mike Sjoström  
Business Manager



BEAUMONT (55.1173)  
EXTENDED PROJECT COST

	Monthly Total Cost	Days/Month	Daily Cost
Extended Project Management	\$ 63,805.71	31	\$ 2,058.25
<small>See Attached Table I</small>			
Extended Project Facilities	\$ 18,197.17	31	\$ 587.01
<small>See Attached Table II</small>			
Extended Labor Manhour	\$ -	31	\$ -
<small>See Attached Table III</small>			
Southern Contracting	\$ -	31	\$ -
<hr/>			
Sub Total:	\$ 82,002.88	31	\$ 2,645.25
Markup 15%:	\$ 12,300.43	31	\$ 396.79
<hr/>			
<b>Total:</b>	<b>\$ 94,303.31</b>		<b>\$ 3,042.04</b>
<hr/>			
Total Days Delayed:		45	\$ 136,891.90

TABLE I - BEAUMONT (55.1173)

EXTENDED PROJECT MANAGEMENT - MONTHLY DURATION EQUATES TO 22 WD - 31 CD

ITEM NO.	TITLE	NAME OF INDIVIDUAL	HOURLY RATE	DAILY RATE	TOTAL WEEKLY RATE	REMARKS
1	Assistant Engineer	Armando Cayama	\$ 47.69	\$ 381.52	\$ 1,907.60	Full time at jobsite
2	Project Engineer	Adam Hickman	\$ 68.23	\$ 545.84	\$ 2,729.20	Full time at jobsite
3	Senior Project Manager	Juan Ahumada	\$ 90.44	\$ 723.52	\$ 723.52	One day a week
4	Project Manager	Oscar Mendoza	\$ 79.24	\$ 633.92	\$ 1,267.84	Two days a week
5	Division Manager	Pat Saleen	\$ 106.27	\$ 850.16	\$ 1,700.32	Two days a month
6	Project Superintendent	Robert Beck	\$ 118.65	\$ 1,067.85	\$ 5,339.25	Full time at jobsite
7	Clerk	Wendy Saleen	\$ 32.70	\$ 261.60	\$ 261.60	One day per week
8	Yardman	Brandon Chew	\$ 41.97	\$ 335.76	\$ 335.76	One day per week
9						
10		Total Amount Per Week:			<b>\$ 14,265.09</b>	
<b>TOTAL COST PER MONTH INCLUDING BOND</b>					<b>\$ 63,805.71</b>	

**TABLE II - BEAUMONT (55.1173)**  
**EXTENDED PROJECT FACILITIES AND SERVICES - DURATION IS 22 WD - 31 CD**

ITEM NO.	DESCRIPTION	QTY.	DURATION	COST OR RATE	EXTENDED COSTS	REMARKS
1	Storage Containers	1	1 month	\$ 135.00 per month	\$ 135.00	
2	PM Office Trailer	1	1 month	\$ 925.00 per month	\$ 925.00	
3	CM/Owner Trailer	1	1 month	\$ 925.00 per month	\$ 925.00	
7	Internet service at project	1	1 month	\$ 500.00 per month	\$ 500.00	
8	Copier service at project	1	1 month	\$ 1,800.00 per month	\$ 1,800.00	
11	Drinking water at project	1	1 month	\$ 120.00 per month	\$ 120.00	
12	Construction water	1	0 month	\$ - per month	\$ -	
13	Janitorial Service for Offices	1	1 month	\$ 400.00 per month	\$ 400.00	
14	Sanitation Services for Field	1	1 month	\$ 600.00 per month	\$ 600.00	
15	Waste disposal services for project	1	1 month	\$ 800.00 per month	\$ 800.00	
18	Jobsite security (Bastion)	1	1 month	\$ 2,500.00 per month	\$ 2,500.00	
19	Builder's Risk	1	1 month	\$ 8,312.00 per month	\$ 8,312.00	
20	Scheduler	1	1 month	\$ 1,000.00 per month	\$ 1,000.00	
<b>TOTAL COST PER MONTH INCLUDING BOND \$ 18,197.17</b>						

---

City of Beaumont Waste Water Treatment Plant  
Salt Mitigation Upgrade Project



Time Impact Analysis 04.1



WM Lyles Co.

## INTRODUCTION

The following narrative outlines the Time Impact Analysis procedure and findings relating to Unforeseen Event 04 – RW/UV and Chemical Area Changes.

### IDENTIFICATION OF SCHEDULE:

Schedule Update Base File: COB\_UP10  
Schedule Analysis File: COB\_TIA04

### TIME IMPACT ANALYSIS METHODOLOGY

The methodology used in this analysis follows a retroactive, “forward-looking” Time Impact Analysis (TIA) procedure. It compares the last approved schedule prior to the first impact event being analyzed to a copy of the same schedule with the addition of modeled schedule impact(s).

The modeled schedule impact events used in the analysis, herein are referred to as “Unforeseen Events” (UFEs), represent events that may impact the schedule and could not have been reasonably foreseen at the time of submitting the original bid for construction. These events are beyond the control, and without fault or negligence of the General Contractor.

The October 2019 schedule progress update was chosen as schedule of comparison to be used in our analysis as it is latest approved schedule update prior to the start of the first delay event being analyzed. A subsequent informal analysis had determined that had the Plant Effluent Chemical Area change order been executed on or before November 20, the schedule would not have been impacted.

WM Lyles is relying on the assumption that the change order for the Plant Effluent Chemical Area will be approved during the next board meeting scheduled for January 7, 2020.

#### Analysis procedure for TIA04:

1. The last submitted schedule (As-Planned Schedule) prior to the start of the first UFE is the October 2019 schedule progress update (UP10).
2. The As-Planned schedule was copied to create the Impacted Schedule of Comparison (TIA04)
3. UFE(s) being analyzed were logically inserted into the Impacted Schedule of Comparison.
4. The affected Project Milestone(s) in the As-Planned schedule were compared to the affected Project Milestone(s) in the Impacted Schedule of Comparison to quantify any impacts resulting from UFE(s).

### UNFORESEEN EVENTS

An Unforeseen Event (UFE) is defined herein as an impact and/or change to the project schedule could not have been reasonably foreseen at the time of submitting a bid for construction and which is beyond the control and without fault or negligence of the General Contractor. As described in clarifications #16, the following changes have been made to the project:



**Unforeseen Event 04 – RW/UV and Chemical Area Changes**

This change order proposal addresses the changes in the chemical area near the recycled water pump station. These changes consist of deleting the sodium hypochlorite chemical storage #2 as shown on drawings C-37 and C-38 (and associated dosing connection point for the recycled water line) and modifying the existing septage receiving station northwest of the Recycled Water Pump Station to function as a chemical containment area for one sodium bisulfite chemical tank and one caustic soda chemical tank. This area will also include the chemical dosing pumps for each system. The sodium bisulfite will be dosed over the effluent weir of the Recycled Water Pump Station and the caustic soda will be dosed in the influent box upstream of the UV channels. The dosing at the UV influent box will include a mechanical mixer. The dosing system at the Recycled Water Pump Station will be a static system but will include chlorine and pH analyzers and a combined controller connected to plant SCADA.

The modifications also include grading and yard piping changes associated with the chemical piping from the chemical storage area to the UV influent box and recycled water pump station

The vertical shaft mixer is driving the critical path of the delay. The current forecast for the fabrication and delivery of the vertical shaft mixer is 14 weeks. Activities representing the steps necessary to implement this change order have been logically added to the schedule. These activities replaced the existing activities in the schedule representing the scope of work being modified / replaced by this change order.

**Schedule Delay Fragment**

Activity ID	Activity Name	OD	RD	Start	Finish	Total Float
UFE04.01	SUBMIT CHANGE ORDER 10-25-2019	1	0	25-Oct-19 A	25-Oct-19 A	
UFE04.02	REVIEW/APPROVE/EXECUTE CHANGE ORDER WITH COB - 4 WEEKS	18	48	28-Oct-19 A	07-Jan-20	-34
UFE04.03	PREPARE PURCHASE ORDER AND EXECUTE FOR VERTICAL SHAFT MIXER	5	5	08-Jan-20	14-Jan-20	-34
UFE04.04	P/S VERTICAL SHAFT MIXER	15	15	15-Jan-20	04-Feb-20	-34
UFE04.05	R/A VERTICAL SHAFT MIXER	15	15	05-Feb-20	25-Feb-20	-34
UFE04.06	F/D VERTICAL SHAFT MIXER	70	70	26-Feb-20	02-Jun-20	-34
UFE04.07	INSTALL VERTICAL SHAFT MIXER	3	3	03-Jun-20	05-Jun-20	-34
UFE04.08	START-UP AND TEST OF NEW VERTICAL SHAFT MIXER	2	2	08-Jun-20	09-Jun-20	-34
MS01	PHASE 1 COMPLETION (450 CD AFTER NTP = 02/06/20 - 04/26/20)	0	0		10-Jun-20*	-48

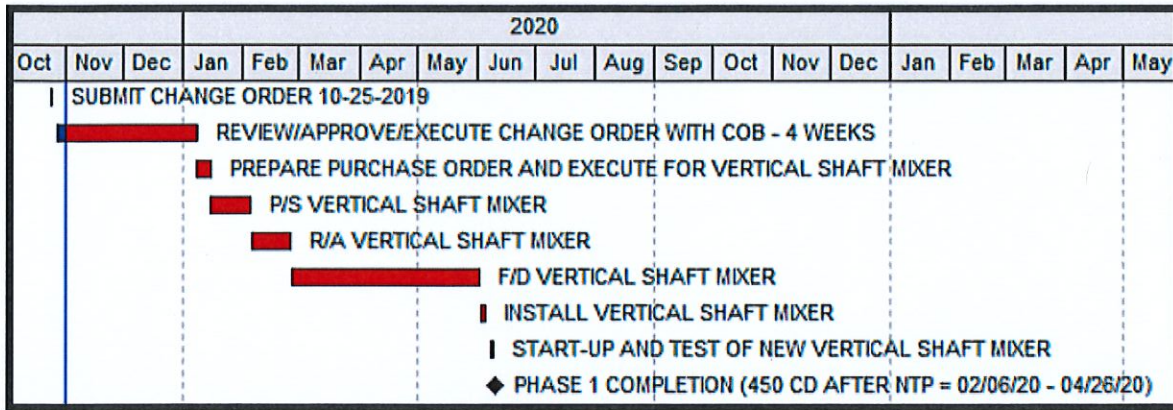

Milestone Comparison

Activity ID	Activity Name	OD	RD	Start	Finish	Total Float
<b>COB WWTP Salt Mitigation Upgrade Project_OCT 2019</b>						
MS01	PHASE 1 COMPLETION (450 CD AFTER NTP = 02/06/20 - 04/26/20)	0	0		02-May-20*	-10
MS01.1	PROJECT SUBSTANTIAL COMPLETION (4 WKS PRIOR TO MS02)	0	0		12-Apr-21	-8
MS02	PHASE 2 COMPLETION (820 CD AFTER NTP = 02/13/21 - 05/01/21)	0	0		10-May-21*	-9
<b>COB WWTP Salt Mitigation Upgrade Project_TIA04</b>						
MS01	PHASE 1 COMPLETION (450 CD AFTER NTP = 02/06/20 - 04/26/20)	0	0		10-Jun-20*	-48
MS01.1	PROJECT SUBSTANTIAL COMPLETION (4 WKS PRIOR TO MS02)	0	0		17-May-21	-43
MS02	PHASE 2 COMPLETION (820 CD AFTER NTP = 02/13/21 - 05/01/21)	0	0		15-Jun-21*	-45

The Phase 1 Completion and Phase 2 Completion Milestones were impacted by UFE04 as follows:

MS01: 48 Calendar Days  
MS02: 45 Calendar Days

NOTE: The schedule is being concurrently impacted by the MBR CHEMICAL AREA AND MISC CHANGES – CLARIFICATIONS #12 / #13.

CONCLUSION

WM Lyles is relying on the assumption that the change order for the Plant Effluent Chemical Area Changes will be approved during the next board meeting scheduled for January 7, 2020.

ATTACHMENTS

P6 Schedule Analysis File: COB\_TIA04\_Impacted Schedule  
11x17 PDF: COB\_TIA04\_Impacted Longest Path







**Item Attachment Documents:****15. Authorize Mayor to Make Appointments to the Various Boards, Commissions and Committees**

## Recommended Action:

Mayoral appointments of City Council members to various boards, commissions and committees.



## Staff Report

**TO:** Mayor, and City Council Members  
**FROM:** Nicole Wheelwright, Deputy City Clerk  
**DATE:** January 07, 2020  
**SUBJECT:** Authorize Mayor to Make Appointments to the Various Boards, Commissions and Committees

---

### Background and Analysis:

As part of an annual reorganization, it is the Mayor's discretion to appoint City Council members to various boards, commissions and committees. The following entities require representatives from the City Council:

Transportation Now

Riverside Transit Agency

Riverside County Transportation

Western Riverside County Regional Conservation Authority

Beaumont Cherry Valley Recreation and Parks District

Beaumont Cherry Valley Water District

Beaumont Unified School District

Legislative Liaison

Collaborative Agency

Eastern Riverside County Interoperable Communications Authority

Southern California Association of Governments

League of California Cities

Memorial Committee

San Geronio Pass Regional Focused High-Collision Reduction Task Force

Finance and Audit Committee

Economic Development Committee

Gorgonio Integrated Water Management Regional Stakeholder Advisory Committee

Western Riverside Council of Governments

Transit Ad-Hoc 2x2 Committee  
Water Re-Use Ad-Hoc 2x2 Committee  
Pass Com

**Fiscal Impact:**

No fiscal impact.

**Recommended Action:**

Mayoral appointments of City Council members to various boards, commissions and committees.

**Item Attachment Documents:**

**16. Status of Pending Litigation**





To: City Council  
From: John O. Pinkney, City Attorney  
Date: December 20, 2019  
Re: Status of Pending Litigation Against City of Beaumont

---

**Pending Litigation Against the City (does not include litigation initiated by the City)**

1. ***Urban Logic v. City of Beaumont et al.***, Case No. RIC 1707201 (Pre-Trial)
2. ***Aguirre et al. v. City of Beaumont et al.***, Case No. RIC 1810937 (Pre-Trial)
3. ***Elizabeth Serrato v. City of Beaumont***, Case No. RIC 1820593 (Pre-Trial)
4. ***Angela Santa Cruz, individually and as Guardian ad litem for M.L.V., a minor v. City of Beaumont et al.***, Case No. 2:18-CV-08427 (Pre-Trial)
5. **Charles Peters dba Pioneer Mobile Village v. City of Beaumont, et. al**, Case No. RIC 1707116