



## **Town of Beaufort, NC**

701 Front St. - P.O. Box 390 - Beaufort, N.C. 28516  
252-728-2141 - 252-728-3982 fax - [www.beaufortnc.org](http://www.beaufortnc.org)

### **Town of Beaufort Historic Preservation Regular Meeting 6:00 PM Tuesday, December 05, 2023 - Train Depot, 614 Broad Street, Beaufort, NC 28516 Monthly Meeting**

---

#### **Call to Order**

#### **Roll Call**

#### **Agenda Approval**

#### **Minutes Approval**

- [1.](#) HPC Draft Minutes 100323 Corrected

#### **Administration of Oaths**

#### **Items of Consent**

- [1.](#) Approval of the Orders for 107 Sunset Lane, 308 Moore Street, 310 ½ Orange Street, 318 Orange Street & 505 Front Street – Certificate of Appropriateness

#### **New Business**

- [1.](#) Case # 23-30 107 Sunset Lane – Fencing & Paves
- [2.](#) Case # 23-31 120 & 120 A Craven Street - Paint, Porch & Lighting
- [3.](#) Case # 23-33 100 Sunset Lane - Fencing, Driveway & Exterior Lighting
- [4.](#) Case # 23-35 121 Craven Street - Brick Walkway
- [5.](#) 2024 Historic Commission Meeting and Submittal Calendar

#### **Commission / Board Comments**

#### **Staff Comments**

#### **Adjourn**



**Town of Beaufort, NC**  
701 Front St. - P.O. Box 390 - Beaufort, N.C. 28516  
252-728-2141 - 252-728-3982 fax - www.beaufortnc.org

**Town of Beaufort Historic Preservation Regular Meeting**  
**6:00 PM Tuesday, October 3, 2023 - Train Depot, 614 Broad Street, Beaufort, NC 28516**  
**Minutes**

---

**Call to Order**

Chair McCune called the October 3, 2023 Beaufort Historic Preservation Commission regular meeting to order at 6:00 pm.

**Roll Call**

Members Present: Chair McCune, Vice-Chair John Flowers, Bradley Cummins, Bradley Hedrick, Ian Huckabee, and Marissa Morris.

Members Absent: Tammy Hunsucker

A quorum was declared with six members present.

Staff Present: Kyle Garner, Town Attorney Jill Quattlebaum, and Laurel Anderson.

**Agenda Approval**

*Member Huckabee made the motion to approve the Agenda and Vice-Chair Flowers made the second. Chair McCune took a vote that was unanimously approved.*

*Voting yea: Chair McCune, Vice-Chair John Flowers, Bradley Cummins, Bradley Hedrick, Ian Huckabee, and Marissa Morris*

**Minutes Approval**

*Member Heckrick made the motion to approve the Agenda and Member Cummins made the second. Chair McCune took a vote that was unanimously approved.*

*Voting yea: Chair McCune, Vice-Chair John Flowers, Bradley Cummins, Bradley Hedrick, Ian Huckabee, and Marissa Morris*

**Administration of Oaths**

Chair McCune gave the Quasi-Judicial Statement and Secretary Anderson administered the Oath to Kyle Garner.

**Items of Consent**

*Member Huckabee made the motion to approve the Order for Case # 23-25 118 Orange Street and Member Morris made the second. Chair McCune took a vote that was unanimously approved.*

*Voting yea: Chair McCune, Vice-Chair Flowers, Bradley Cummins, Bradley Hedrick, Ian Huckabee, and Marissa Morris*

**Old Business**

- 1. Case #23-26; 107 Sunset Ln – Demolition

Chair McCune introduced Case #23-26 and asked if any members needed to recuse and hearing none, she asked for the Staff Report. Mr. Garner explained that Staff met with the applicant and owner after the September 5th HPC meeting where all parties agreed to separate the original request (demo of structure, adding fencing and pavers) into two separate applications with this one being just for the demo only. An email from John Wood has also been provided as to the structure not being a contributing structure, which also means it does not meet the criteria of being Historically Significant. Per Section 23-J-1 (Demolition of Buildings).

Member Hedrick asked if the only consideration should be if the structure has statewide significance and Mr. Garner explained that the decision was up to the Board.

Secretary Anderson administered the Oath to the applicant’s architect and agent, Maggie Chalk. She stated that she had met with John Wood in August and they had toured the house, and an accompanying intern representing the National Trust also agreed that the structure was non-contributing in the Beaufort historic district.

Member Hedrick asked if there were any plans to rebuild another structure on that site and Ms. Chalk stated that there were none at this time, and the existing building is deteriorated and vacant.

Member Huckabee requested the homeowner salvage any usable materials, noting that the Guidelines suggested the salvaging of materials from demolished structures. Member Hedrick noted that all types of homes in the historic district are representative of the people who lived in the community, and small surviving cottages represent the builders, time and place of our historic district, and lamented the loss of another house in the district.

*Chair McCune asked if there were any parties with standing, and hearing none and no further questions, asked for a motion for a Finding of Fact for Case #23-26. Vice-Chair Flowers made the following motion: Having reviewed the record and having considered all evidence submitted and oral testimony for case #23-26, move that the Commission conclude that the pending application meets the following design standards under the Design Guidelines for the Beaufort Historic District and Landmarks: Demolition Guidelines 10.1.1, 10.1.2, 10.1.3, 10.1.4, 10.1.5, and 10.1.6.*

*Member Morris made the second. Chair McCune took a vote that was unanimously approved.*

*Voting yea: Chair McCune, Vice-Chair John Flowers, Bradley Cummins, Bradley Hedrick, Ian Huckabee, and Marissa Morris*

Chair McCune then asked for a motion for a Certificate of Appropriateness for Case #23-26.

*Member Huckabee made a motion to approve the Certificate of Appropriateness based on the following: Based upon the foregoing Findings of Fact, I move that the proposed project is not incongruous with the special character of the historic district as a whole and that a Certificate of Appropriateness for Case #23-26 be issued for the proposed work.*

*Member Cummins made the second. Chair McCune took a vote that was unanimously approved.*

*Voting yea: Chair McCune, Vice-Chair John Flowers, Bradley Cummins, Bradley Hedrick, Ian Huckabee, and*

*Marissa Morris*

Chair McCune then declared Case #23-26 closed and notified Ms. Chalk that the Minutes and Findings of Fact would be adopted at the next meeting and the COA would then be issued.

2. Case #23-30; 107 Sunset Lane –Fencing & Pavers

Town Attorney Quattlebaum reminded the Board that this matter had been continued from the last month as there appeared to be an encroachment on Town of Beaufort property and the Town Manager requested the Town Attorney’s determine if there were any issues with the property ownership. She stated that the information had been researched and forwarded to the Town Manager and Mr. Garner, and that there did appear to be an issue as they cannot confirm that the property owner/applicant owns the property on which the pavers are intended to go. She recommended the matter be tabled until proof of ownership and property boundaries had been resolved. She also noted that a formal title search had not been performed yet and tabling the application would also give the applicant time to provide proof of ownership.

*Vice-Chair Flowers made a motion to table Case #23-30 until the matters of concern have been resolved. Member Morris made the second and Chair McCune took a vote that was unanimously approved.*

*Voting yea: Chair McCune, Vice-Chair John Flowers, Bradley Cummins, Bradley Hedrick, Ian Huckabee, and Marissa Morris*

Chair McCune declared Case #23-30 tabled until further notice.

3. Case #23-07 308 Moore St – Roof, Paint, Windows, Fence & Landscaping

Chair McCune introduced Case #23-07 and asked if any members needed to recuse themselves and Member Morris stated that she did.

*Member Cummins made a motion to recuse Member Morris. Member Huckabee made the second and Chair McCune took a vote that was unanimously approved.*

*Voting yea: Chair McCune, Vice-Chair John Flowers, Bradley Cummins, Bradley Hedrick, and Ian Huckabee*

Chair McCune then asked Mr. Garner for the Staff Report. He explained that Member Morris recused herself as she has a contract with the applicant’s contractor. He stated that in March 2023 the Commission approved the construction of a new structure at 308 Moore St except for the metal roof which was tabled to return to the HPC. The property owner has now submitted a request for the metal roof as well as other items they would like to be modified which are as follows: Painted front door color; elimination of diamond pattern from gable window mullions; garage door garage porch roof will be shingled, not metal; change back of garage window to door (with window); elimination of part of front yard fence; straighten walkway from front door to street; and increase rear privacy fence from 66” to 72”.

Member Cummins clarified that the garage would be a shingle roof rather than a metal roof.

Secretary Anderson administered the Oath to the applicant, Ben Lapsley. He noted that the requested metal roof would be a 1” standing seam. He also explained the notations in red on the proposed plans. Member Cummins discussed Guideline 6.1.3 as it pertains to a large agricultural ridge cap and noted that the plans did not show that unacceptable type of ridge cap. There was discussion regarding the planned ridge cap and Member Cummins stated that it should be flat. Vice-Chair read the guideline in question stating “Galvanized standing seam with a large “agricultural” ridge, usually for ventilation, is not acceptable in the historic district.”

Mr. Lapsley requested that if a fortified metal roof was not appropriate under the Guidelines that approval be given for a shingle roof, and the Board agreed th

*Chair McCune asked if there were any parties with standing, and hearing none and no further questions, asked for a motion for a Finding of Fact for Case #23-07. Vice-Chair Flowers made the following motion: Having reviewed the record and having considered all evidence submitted and oral testimony for case #23-07, move that the Commission conclude that the pending application meets the following design standards under the Design Guidelines for the Beaufort Historic District and Landmarks: Roofing Guidelines 6.1.3; Paint and Exterior Colors Guidelines 6.7.2; Window and Door Guidelines 6.4.7, 6.4.10; Landscaping Guidelines 8.1.2, 8.1.5, 8.1.7, 8.1.11; Fences and Walls Guidelines 8.2.2, 8.2.3; with the condition that if a metal roof could not be fortified without an agricultural roof cap, that shingles matching the house would be approved.*

*Member Hedrick made the second. Chair McCune took a vote that was unanimously approved.*

*Voting yea: Chair McCune, Vice-Chair John Flowers, Bradley Cummins, Bradley Hedrick, and Ian Huckabee*

Chair McCune then asked for a motion for a Certificate of Appropriateness for Case #23-07.

*Member Huckabee made a motion to approve the Certificate of Appropriateness based on the following: Based upon the foregoing Findings of Fact, I move that the proposed project is not incongruous with the special character of the historic district as a whole and that a Certificate of Appropriateness for Case #23-07 be issued for the proposed work, with the condition that if the metal roof could not be fortified without an agricultural roof cap, that shingles matching the house would be approved.*

*Vice-Chair Flowers made the second. Chair McCune took a vote that was unanimously approved.*

*Voting yea: Chair McCune, Vice-Chair John Flowers, Bradley Cummins, Bradley Hedrick, and Ian Huckabee*

Chair McCune then declared Case #23-07 closed and notified Mr. Lapsley that the Minutes and Findings of Fact would be adopted at the next meeting and the COA would then be issued.

*Vice-Chair Flowers made a motion to restore Member Morris to the Board. Member Cummins made the second and Chair McCune took a vote that was unanimously approved.*

*Voting yea: Chair McCune, Vice-Chair John Flowers, Bradley Cummins, Bradley Hedrick, and Ian Huckabee*

**New Business**

1. Case #23-27 505 Front St – Exterior Lighting

Chair McCune introduced Case #23-27 and asked if any members needed to recuse themselves and Member Hedrick stated that he did, explaining that his company was contracted to do the work at 505 Front St.

*Vice-Chair Flowers made a motion to recuse Member Hedrick. Member Morris made the second and Chair McCune took a vote that was unanimously approved.*

*Voting yea: Chair McCune, Vice-Chair John Flowers, Bradley Cummins, Ian Huckabee, and Marissa Morris*

Chair McCune then asked Mr. Garner for the Staff Report. He explained that Hunter Young was contracted by the homeowners to add three recessed lights on the front porch.

Secretary Anderson administered the Oath to the applicant’s contractor, Hunter Young of H.A. Young Contracting. He explained that there was a need for more lighting on the front porch for safety purposes.

Member Morris asked about the hue of the lighting and Mr. Young explained that it was adjustable but they would be using the soft white hue.

Vice-Chair Flowers asked where the lights would be installed and Mr. Young stated that they would be centered over the windows and centered in the depth of the porch. Mr. Garner supplied a photo of the house which was entered into the record.

Chair McCune expressed her concern that the requested light fixtures were of a contemporary style which with the height of the house and porch could be seen from the road and suggested using a more subtle lighting installed under the railings going up to the porch. There was a short discussion regarding painting the white plastic trim of the lighting to blend in with the porch ceiling color. Vice-Chair Flowers asked what size light was requested and Mr. Young stated that they had not specified in the application but the homeowners would probably use the 4”.

*Chair McCune asked if there were any parties with standing, and hearing none and no further questions, asked for a motion for a Finding of Fact for Case #23-27.*

Member Cummins interjected and stated that painting the light trim did not seem necessary, and Chair McCune agreed that the paint probably would not stay on the plastic. Member Cummins stated that lighting on the porch would probably make the stairs more dangerous due to casting shadows, and Member Morris agreed with him.

*After a short discussion regarding the congruity of the requested lighting, Chair McCune requested a motion for a Finding of Fact. Vice-Chair Flowers made the following motion: Having reviewed the record and having considered all evidence submitted and oral testimony for case #23-27, move that the Commission conclude that the pending application fails to meet the following design standards under the Design Guidelines for the Beaufort Historic District and Landmarks: Exterior Lighting 8.4.1, 8.4.2, 8.4.3.*

*Member Huckabee made the second. Chair McCune took a vote that was unanimously approved.*

*Voting yea: Chair McCune, Vice-Chair John Flowers, Bradley Cummins, Ian Huckabee, and Marissa Morris*

Chair McCune then asked for a motion for a Certificate of Appropriateness against Case #23-27.

*Member Huckabee made a motion to deny the Certificate of Appropriateness based on the following: Based upon the foregoing Findings of Fact, I move that the proposed project is incongruous with the special character of the historic district as a whole and that a Certificate of Appropriateness for Case #23-27 not be issued for the proposed work.*

*Vice-Chair Flowers made the second. Chair McCune took a vote that was unanimously approved.*

*Voting yea: Chair McCune, Vice-Chair John Flowers, Bradley Cummins, Ian Huckabee, and Marissa Morris*

Chair McCune expressed the hope to Mr. Young that he could find a solution that would be congruous with the house. Mr. Garner asked the Board to give Mr. Young some acceptable parameters for lighting, and they suggested inset lighting under the railings and to avoid modern lighting that could be seen from the porch, possibly hidden behind the decorative gingerbread trim. Mr. Young asked if a surface mount on the risers would be permissible. Chair McCune asked Mr. Garner if a board member could meet with Mr. Young to go over acceptable ideas, and Mr. Garner agreed and stated that the applicant would not be charged another application fee when he reapplied. Vice-Chair Flowers offered for Mr. Young to email Mr. Garner and him some ideas, and Mr. Garner went on the record to explain that the Board would still have to approve the application.

Chair McCune then declared Case #23-27 closed.

*Vice-Chair Flowers made a motion to restore Member Hedrick to the Board. Member Morris made the second and Chair McCune took a vote that was unanimously approved.*

*Voting yea: Chair McCune, Vice-Chair John Flowers, Bradley Cummins, Ian Huckabee and Marissa Morris*

2. Case # 23-28 318 Orange Street - Addition to Rear Yard Cottage

Chair McCune introduced Case #23-28 and asked if any members needed to recuse themselves and hearing none, asked Mr. Garner for the Staff Report. He stated that the owner wishes to make an addition to the existing 14' X 26' rear yard cottage and requested the Staff Report be entered into the record. In April 2015, a COA was issued for a 14' x 26' rear cottage matching the existing house. The rear cottage is not a historic structure. Staff was unable to find where the applicant provided the guidelines that were applicable to the application. Mr. Garner further stated that the siding request is for wood grain and a requirement to use the smooth side would not match the existing structure, but Staff was putting forward no opinion.

Secretary Anderson administered the Oath to the applicant's designer, Christina Colucci. She stated that she continued to request cedar-milled siding on COA applications as the Board had indicated in the past that they may begin accepting those especially on new structures. The Board clarified that she was trying to match the existing siding on the structure.

*Chair McCune asked if there were any parties with standing, and hearing none and no further questions, asked for a motion for a Finding of Fact for Case #23-28. Vice-Chair Flowers made the following motion: Having reviewed the record and having considered all evidence submitted and oral testimony for case #23-07, move that the Commission conclude that the pending application meets the following design standards under the Design Guidelines for the Beaufort Historic District and Landmarks: Roofing Guidelines 6.1.3, 6.1.7; Window and Door Guidelines 6.4.7, 6.4.10; Wood Siding, Trim, and Doors Guidelines 6.2.11.*

*Member Cummins made the second. Chair McCune took a vote that was unanimously approved.*

*Voting yea: Chair McCune, Vice-Chair John Flowers, Bradley Cummins, Bradley Hedrick, Ian Huckabee, and Marissa Morris*

Chair McCune then asked for a motion for a Certificate of Appropriateness for Case #23-28.

*Member Hedrick made a motion to approve the Certificate of Appropriateness based on the following: Based upon the foregoing Findings of Fact, I move that the proposed project is not incongruous with the special character of the historic district as a whole and that a Certificate of Appropriateness for Case #23-28 be issued for the proposed work.*

*Member Huckabee made the second. Chair McCune took a vote that was unanimously approved.*

*Voting yea: Chair McCune, Vice-Chair John Flowers, Bradley Cummins, Bradley Hedrick, Ian Huckabee, and Marissa Morris*

Chair McCune then declared Case #23-28 closed and notified Ms. Colucci that the Minutes and Findings of Fact would be adopted at the next meeting and the COA would then be issued.

3. Case # 23-29 310 ½ Orange Street - Demolish House and Shed

Chair McCune introduced Case #23-29 and asked if any members needed to recuse themselves. Vice-Chair Flowers stated that he did, explaining that he was the agent for the owners at 310 ½ Orange St.

*Member Huckabee made a motion to recuse Vice-Chair Flowers. Member Morris made the second and Chair McCune took a vote that was unanimously approved.*

*Voting yea: Chair McCune, Bradley Cummins, Bradley Hedrick, Ian Huckabee, and Marissa Morris*

Chair McCune then asked Mr. Garner for the Staff Report. He stated that there is no history of prior COA's for this property. John Wood and Lauren Poole of the State Historic Preservation Office agreed the structure was not a structure of statewide significance. However, an email to the applicant's agent (John Flowers) from Town Staff with John Wood copied on the email has also been provided as to the structure being a contributing structure and outlining the requirement for future development on the site, so a future replacement structure would have to match in height, size, scale, mass, and proportion. Even though the structure is contributing it does not meet the criteria of being Historically Significant. Per Section 23-J-1 (Demolition of Buildings).

Chair McCune clarified that this application was only for the demolition of the existing structure, and Mr. Garner agreed and stated for the record that the Guidelines required a replacement for a contributing structure to meet the height, size, scale, mass, and proportion of the demolished house. Chair McCune identified the need to record those attributes of the existing house and Mr. Garner stated that it could be requested. Member Hedrick asked if there was a requirement to replace the structure if the current one is demolished so a hole would not be left in the fabric of the historic district, and Mr. Garner explained that there was not a requirement to build a new structure but if a new house were built it would have to match the demolished one.

Secretary Anderson administered the Oath to the applicant's agent, John Flowers. Mr. Garner explained that an update of Chapter 160-D requires signed and notarized verification stating that a contractor or other project supervisor is the agent of the homeowner, and in future this will be required of all applications. He further stated that in this case the homeowners had supplied that verification.

Mr. Flowers stated that the house to be demolished was behind another house and had not been taken care of for a while and he explained some of the structure issues, describing general deterioration. As the house is still occupied he stated he could not document the existing building but would do so when the tenants moved out.

Member Hedrick stated that as the structure could not be seen from the street which would lessen the impact of demolition. Member Cummins asked if the house could be fixed and Mr. Flowers stated that almost anything could be fixed but there would be few boards left of the original structure. He also stated that photos and documentation of the house to be demolished could be submitted when requesting a COA for a new house.

Chair McCune asked if there were any parties with standing, and Secretary Anderson administered the Oath to an adjacent homeowner, Laura Benson. She stated that she and her husband owned the adjacent property and that they would not be opposed to the demolition but they were concerned about the logistics of the demo such as impact to access and damage to pavers and fencing as well as access of demolition equipment.

Secretary Anderson then administered the Oath to another adjacent homeowner, Wendy Davidson of 307 Turner St, and explained the property under discussion was behind her property. She expressed her concern regarding damage to her property from the demolition but stated that she was not opposed to the demo or a new structure being built there.

The Board had a short discussion regarding the demolition and Member Huckabee asked if the Board could make a condition addressing the neighbor's concerns, and Town Attorney Quattlebaum explained that would be a private agreement between the homeowner and the neighbors. Chair McCune reiterated Ms. Quattlebaum's statement regarding the homeowner and neighbors working together.

*Chair McCune for a motion for a Finding of Fact for Case #23-29. Member Hedrick made the following motion: Having reviewed the record and having considered all evidence submitted and oral testimony for case #23-28, move that the Commission conclude that the pending application meets the following design standards under the Design Guidelines for the Beaufort Historic District and Landmarks: Demolition 10.1.1, 10.1.2, 10.1.3, 10.1.4, 10.1.5, 10.1.6.*

*Member Huckabee made the second. Chair McCune took a vote that was unanimously approved.*

*Voting yea: Chair McCune, Bradley Cummins, Brad Hedrick, Ian Huckabee, and Marissa Morris*



Chair McCune then asked for a motion for a Certificate of Appropriateness for Case #23-29.

*Member Huckabee made a motion to approve the Certificate of Appropriateness based on the following: Based upon the foregoing Findings of Fact, I move that the proposed project is not incongruous with the special character of the historic district as a whole and that a Certificate of Appropriateness for Case #23-29 be issued for the proposed work, with the condition that if the metal roof could not be fortified without an agricultural roof cap, that shingles matching the house would be approved.*

*Member Morris made the second. Chair McCune took a vote that was unanimously approved.*

*Voting yea: Chair McCune, Bradley Cummins, Bradley Hedrick, Ian Huckabee, and Marissa Morris*

Chair McCune then declared Case #23-29 closed and notified Mr. Flowers that the Minutes and Findings of Fact would be adopted at the next meeting and the COA would then be issued.

*Member Hedrick made a motion to restore Member Hedrick to the Board. Member Morris made the second and Chair McCune took a vote that was unanimously approved.*

*Voting yea: Chair McCune, Bradley Cummins, Bradley Hedrick, Ian Huckabee and Marissa Morris*

**Commission / Board Comments**

- a. Member Hedrick noted that windows were being changed at 120 Craven St and asked if there could be a decision made on requiring compliance with the standards of the Guidelines when Minor Works were requested.
- b. Vice-Chair Flowers asked if the new house on Sunset Lane had been approved for the vinyl rail on the porch and Mr. Garner stated that any HPC member could come into Town Hall to review COA applications and approvals.
- c. Member Cummins expressed his concern regarding the demolition of houses in the historic district and proposed adding a provision to require a reuse plan before demolition is allowed. He challenged the other Board members to decide where to draw the line on future demolition requests and advocate the preservation of these structures and possibly changing the new Standards or Land Development Ordinance. Member Hedrick agreed and reminded the Board about a previous COA request to raise a house in order to preserve it.
- d. Member Morris suggested Minor Works items be reviewed by HPC board members and Chair McCune explained that one Board member could not make a decision without the rest of the board, and her personal opinion was that a homeowner should have the ability to repair their house without going through the full COA process.

**Staff Comments**

- a. Mr. Garner stated that he did not disagree with Member Hedrick about the windows he discussed and he was not opposed to changing the Standards to require Minor Works requests adhere to the guidelines.
- b. He noted that the last COA application on tonight’s agenda was a nonconforming lot of record and it could be built upon and the future property owner was aware of that.
- c. Mr. Garner informed the board that the new build at 111 Moore St had an unauthorized historic plaque and he and Ms. Quattlebaum would be discussing that issue.
- d. He notified the board of the upcoming Historic Resilience Workshop to be held in New Bern on December 7, 2023.

**Adjourn**

*Vice-Chair Flowers made the motion to adjourn and Member Cummins made the second. Chair McCune took a vote that was unanimously approved.*

*Voting yea: Chair McCune, Vice-Chair John Flowers, Bradley Cummins, Bradley Hedrick, Ian Huckabee, and Marissa Morris*

Chair McCune declared the October 3<sup>rd</sup>, 2023 meeting adjourned.

---

Chair, Joyce McCune

---

Board Secretary, Laurel Anderson



**Town of Beaufort, NC**

701 Front St. - P.O. Box 390 - Beaufort, N.C. 28516  
252-728-2141 - 252-728-3982 fax - www.beaufortnc.org

**Town of Beaufort Historic Preservation Commission  
6:00 P.M. November 7, 2023 – 614 Broad Street – Train Depot**

---

**AGENDA CATEGORY:** Consent  
**SUBJECT:** Approval of the Orders for 107 Sunset Lane, 308 Moore Street, 310 ½ Orange Street, 318 Orange Street & 505 Front Street – Certificate of Appropriateness

**BRIEF SUMMARY:**

As part of the new General Statutes (160D), prior to Evidentiary Hearing Orders being signed and sent to the applicant/property owners, the Board in which conducted the hearing is to review the order for accuracy.

The staff has consulted with the Town Attorney and now asks that the Historic Commission Members review the orders for such accuracy and be prepared to make a motion to recommend approval of the Order or to approve with Commission recommended changes.

**REQUESTED ACTION:**

Review the order for such accuracy and be prepared to make a motion to recommend approval of the Order or to approve with Commission recommended changes.

**EXPECTED LENGTH OF PRESENTATION:**

0 Minutes (Presentation from Staff)

**SUBMITTED BY:**

Kyle Garner, AICP Planning Director

**BUDGET AMENDMENT REQUIRED:**

N/A



Town of Beaufort  
701 Front St. • P.O. Box 390 • Beaufort, N.C. 28516  
252-728-2141 • 252-728-3982 fax  
[www.beaufortnc.org](http://www.beaufortnc.org)

November 7, 2023

Victor I. Flow Jr.  
18 Graylyn Place Court  
Winston Salem, NC 27106

RE: Case # 23-26 107 Sunset Lane – Demolition

Dear Mr. Flow:

Beaufort's Historic Preservation Commission wishes to thank you for your recent application for a Certificate of Appropriateness regarding the property referenced above which is in the Town's Historic District. We appreciate you taking the time to come before the Commission, as well as your willingness to work with us to preserve the distinctive character of Beaufort. Your commitment will help ensure the many historic and cultural resources that we enjoy today will be preserved for future generations.

You have been issued a Certificate of Appropriateness for your project as specified on the enclosed certificate. Please read it carefully. As you proceed with your project, you must comply with all the specifications stated, including provisions in the relevant Historic District Guidelines enumerated on the certificate. Please note the COA must be visibly displayed at the site during the entire duration of the project. Also note that a building permit with the Town may be needed depending on the scope of the work.

Your certificate is valid for the work which must begin within six (6) months from the date of issuance of the COA by the Commission and must be completed no later than one year thereafter. An extension of the COA can be granted upon the Town receiving a written request from the applicant prior to the application expiration date. An extension may only be granted once for a time period of six additional months if the work has been started but not completed within the one-year validation period. Upon completion of your project please contact our office in case an inspection of the project is required.

Thank you for the thought and care that you have dedicated to your project. Your contribution to the preservation of Beaufort's Historic District is greatly appreciated.

Sincerely,

Joyce McCune, Chair  
Beaufort Historic Preservation Commission

Enclosed: COA Certificate



TOWN OF BEAUFORT, NC  
ORDER GRANTING A CERTIFICATE OF APPROPRIATENESS

The Historic Preservation Commission for the Town of Beaufort, N.C. (“HPC”), having held an evidentiary hearing on October 3, 2023, to consider a Certificate of Appropriateness (“COA”) application submitted by Victor I. Flow Jr. for **CASE # 23-26 107 SUNSET LANE – DEMOLITION** and having heard all of the evidence, testimony, and arguments presented during the evidentiary hearing on this item and having the material(s) submitted to the HPC from the applicant, makes the following CONCLUSION:

Based upon the testimony, evidence, and record before the HPC on October 3, 2023, we find that the application submitted meets the following design standards under the Design Guidelines for the Beaufort Historic District & Landmarks [revised 2008]:

*Demolition of Buildings Guidelines*

10.1.1. Choose demolition only as a last resort. Property owners of contributing buildings should design the replacement building to reflect the demolished building’s height, scale, massing and location. Applicants will have a heavy burden to demonstrate to the HPC that a replacement building with different height, scale, massing as the previously existing building is congruous with the Historic District.

10.1.2. Document the historic resource prior to demolition. Documentation shall take the form of black and white photographs, and color digital photographs of the building, structure, or site’s principal elevations, architectural elements (both in exterior and interior), and special features. Measured drawings of the resource may also be required. The HPC shall determine on a case-by-case basis the extent of documentation required and the parties responsible for producing such documentation. The documentation shall be submitted to the HPC and become a permanent record of the Town of Beaufort.

10.1.3. Salvage architectural features and building materials for reuse or study. Contact antique dealers and used building supply establishments to arrange for removal. Consider donations of items to interested non-profit organizations or museums or the NC-SHPO.

10.1.4. Minimize ground-disturbing activities during demolition to avoid damage to potential unknown Archaeological resources.

10.1.5. Retain mature trees on site.

10.1.6. Clean the site thoroughly of all building debris and leave the lot properly graded and seeded.

THEREFORE, IT IS ORDERED based on the application submitted, the testimony given during the evidentiary hearing and the foregoing findings of fact, the HPC concludes that the proposed project is congruous with the special character of the Historic District as a whole and that a Certificate of Appropriateness be **ISSUED** for CASE # 23-26 107 SUNSET LANE – DEMOLITION.

This the 7<sup>th</sup> day of Novemberr, 2023

\_\_\_\_\_  
Joyce McCune, Chair  
Beaufort Historic Preservation Commission

NOTE: If you are dissatisfied with the decision of this Board, an appeal may be taken to the Beaufort Board of Adjustment within 30 days after the date this order is served on you.



Town of Beaufort  
701 Front St. • P.O. Box 390 • Beaufort, N.C. 28516  
252-728-2141 • 252-728-3982 fax  
[www.beaufortnc.org](http://www.beaufortnc.org)

November 7, 2023

Craven Gardner Design & Build  
301 East Fort Macon Road  
Atlantic Beach, NC 28512

RE: Case # 23-07 308 Moore Street – Roof, Paint, Windows, Fence & Landscaping

Dear Craven Gardner Design & Build:

Beaufort's Historic Preservation Commission wishes to thank you for your recent application for a revision of Certificate of Appropriateness regarding the property referenced above which is in the Town's Historic District. We appreciate you taking the time to come before the Commission, as well as your willingness to work with us to preserve the distinctive character of Beaufort. Your commitment will help ensure the many historic and cultural resources that we enjoy today will be preserved for future generations.

You have been issued a Certificate of Appropriateness for your project as specified on the enclosed certificate. Please read it carefully. As you proceed with your project, you must comply with all the specifications stated, including provisions in the relevant Historic District Guidelines enumerated on the certificate. Please note the COA must be visibly displayed at the site during the entire duration of the project. Also note that a building permit with the Town may be needed depending on the scope of the work.

Your certificate is valid for the work which must begin within six (6) months from the date of issuance of the COA by the Commission and must be completed no later than one year thereafter. An extension of the COA can be granted upon the Town receiving a written request from the applicant prior to the application expiration date. An extension may only be granted once for a time period of six additional months if the work has been started but not completed within the one-year validation period. Upon completion of your project please contact our office in case an inspection of the project is required.

Thank you for the thought and care that you have dedicated to your project. Your contribution to the preservation of Beaufort's Historic District is greatly appreciated.

Sincerely,

Joyce McCune, Chair  
Beaufort Historic Preservation Commission

CC: Ben Lapsley

Enclosed: COA Certificate

Mayor Sharon Harker  
Commissioner John Hagle • Commissioner Marianna Hollinshed  
Commissioner Bucky Oliver • Commissioner [redacted] in Cooper • Commissioner Bob Terwilliger  
Town Manager [redacted] Todd Clark



TOWN OF BEAUFORT, NC  
ORDER GRANTING A CERTIFICATE OF APPROPRIATENESS

The Historic Preservation Commission for the Town of Beaufort, N.C. (“HPC”), having held an evidentiary hearing on October 3, 2023 to consider a Certificate of Appropriateness (“COA”) application submitted by Craven Gardner Design & Build for **CASE # 23-07 308 MOORE STREET – ROOF, PAINT, WINDOWS, FENCE & LANDSCAPING** and having heard all of the evidence, testimony, and arguments presented during the evidentiary hearing on this item and having the material(s) submitted to the HPC from the applicant, makes the following CONCLUSION:

Based upon the testimony, evidence, and record before the HPC on October 3, 2023, we find that the application submitted meets the following design standards under the Design Guidelines for the Beaufort Historic District & Landmarks [revised 2008]:

*Roof Guidelines*

6.1.3 New roofing materials should be compatible with either the existing or original roofing material. Match the historic material as closely as possible in color, shape, size, and texture. Asphalt or fiberglass - asphalt shingles are acceptable substitutes for standing-seam tin, wood shingles, or metal shingles. Any distinctive patterns of shingles or slates shall be retained and/or replicated exactly. Galvanized standing - seam with a large “agricultural” ridge, usually for ventilation, is not acceptable in the historic district. Instead, use standing seam metal with a crimped edge.

*Paint and Exterior Colors Guidelines*

6.7.2. Determine the building’s style and period and consult with the HPC or reference sources for the most appropriate paint colors. Use paint colors that are appropriate for the style and period of the subject property and that accentuate the building’s architectural features.

*Window and Door Guidelines*

6.4.7. New windows must match original in overall size and opening area and should have three dimensional muntins with either true divided lights (TDL) or three dimensional grilles on both the interior and exterior sides (SDL). Snap-in grilles or grilles between glass are not appropriate for windows visible from public view.

6.4.10. New window and door openings shall not alter the historic character of the building or cause damage to historic materials or other significant architectural features. They must be detailed and sized to be compatible with the existing structure.

*Landscaping Guidelines*

8.1.2. Preserve and maintain the individual components and historic features that contribute to Beaufort’s historic character, including mature trees, ornamental trees, and hedge rows.

8.1.5. All new plant materials selected for replanting or new planting in publicly visible areas should complement as much as possible those found on the site and in the surrounding area of the district.



8.1.7. Maintain the relationship between the mass/proportion of the building and open space within the context of the streetscape for new construction, additions and landscape.

8.1.11. Historic sidewalks and other paving materials should be preserved and maintained. New sidewalks shall be compatible in material, detailing, color and finish to existing historic sidewalks.

*Fences and Walls Guidelines*

8.2.2. Design new fences that are compatible with the associated building, site and streetscape in height, proportion, scale, color, texture, material and design. Substitute fence materials are not allowed along front or visible side property lines in the historic district. Fence types such as wire, hurricane, chain-link, vinyl, corrugated metal, stockade, and wooden post and rail are not allowed in public view.

8.2.3. Fences shall not exceed a height of four (4) feet in front yards and other areas of primary visual concern. Fences at rear yards and other areas not readily seen from the public view may be up to six (6) feet high. The transition between low front fences and higher rear fences should be made as far to the rear of the enclosed structure or yard as possible, and no more than half the depth of the yard forward of the principal structure. Avoid attaching a portion of the fence to a building because of possible termite damage.

THEREFORE, IT IS ORDERED based on the application submitted, the testimony given during the evidentiary hearing and the foregoing findings of fact, the HPC concludes that the proposed project is congruous with the special character of the Historic District as a whole and that a Certificate of Appropriateness be **ISSUED** for CASE # 23-07 308 MOORE STREET – ROOF, PAINT, WINDOWS, FENCE & LANDSCAPING – with the condition that if a metal roof without an endcap cannot be constructed, the applicant will use a shingle roof with shingles the same color as the house.

This the 3<sup>rd</sup> day of October, 2023

\_\_\_\_\_  
Joyce McCune, Chair  
Beaufort Historic Preservation Commission

NOTE: If you are dissatisfied with the decision of this Board, an appeal may be taken to the Beaufort Board of Adjustment within 30 days after the date this order is served on you.



Town of Beaufort  
701 Front St. • P.O. Box 390 • Beaufort, N.C. 28516  
252-728-2141 • 252-728-3982 fax  
[www.beaufortnc.org](http://www.beaufortnc.org)

November 7, 2023

BMS Partners, LLC  
304 Roslyn Road  
Richmond, VA 23226

RE: Case # 23-29 310 ½ Orange Street – Demolish House and Shed

Dear Sirs:

Beaufort's Historic Preservation Commission wishes to thank you for your recent application for a Certificate of Appropriateness regarding the property referenced above which is in the Town's Historic District. We appreciate you taking the time to come before the Commission, as well as your willingness to work with us to preserve the distinctive character of Beaufort. Your commitment will help ensure the many historic and cultural resources that we enjoy today will be preserved for future generations.

You have been issued a Certificate of Appropriateness for your project as specified on the enclosed certificate. Please read it carefully. As you proceed with your project, you must comply with all the specifications stated, including provisions in the relevant Historic District Guidelines enumerated on the certificate. Please note the COA must be visibly displayed at the site during the entire duration of the project. Also note that a building permit with the Town may be needed depending on the scope of the work.

Your certificate is valid for the work which must begin within six (6) months from the date of issuance of the COA by the Commission and must be completed no later than one year thereafter. An extension of the COA can be granted upon the Town receiving a written request from the applicant prior to the application expiration date. An extension may only be granted once for a time period of six additional months if the work has been started but not completed within the one-year validation period. Upon completion of your project please contact our office in case an inspection of the project is required.

Thank you for the thought and care that you have dedicated to your project. Your contribution to the preservation of Beaufort's Historic District is greatly appreciated.

Sincerely,

Joyce McCune, Chair  
Beaufort Historic Preservation Commission

CC: Brent and Kelly Creelman

Enclosed: COA Certificate



TOWN OF BEAUFORT, NC  
ORDER GRANTING A CERTIFICATE OF APPROPRIATENESS

The Historic Preservation Commission for the Town of Beaufort, N.C. (“HPC”), having held an evidentiary hearing on October 3, 2023, to consider a Certificate of Appropriateness (“COA”) application submitted by BMS Partners, LLC for **CASE # 23-29 310 ½ ORANGE STREET – DEMOLISH HOUSE AND SHED** and having heard all of the evidence, testimony, and arguments presented during the evidentiary hearing on this item and having the material(s) submitted to the HPC from the applicant, makes the following CONCLUSION:

Based upon the testimony, evidence, and record before the HPC on October 3, 2023, we find that the application submitted meets the following design standards under the Design Guidelines for the Beaufort Historic District & Landmarks [revised 2008]:

*Demolition of Buildings Guidelines*

10.1.1. Choose demolition only as a last resort. Property owners of contributing buildings should design the replacement building to reflect the demolished building’s height, scale, massing and location. Applicants will have a heavy burden to demonstrate to the HPC that a replacement building with different height, scale, massing as the previously existing building is congruous with the Historic District.

10.1.2. Document the historic resource prior to demolition. Documentation shall take the form of black and white photographs, and color digital photographs of the building, structure, or site’s principal elevations, architectural elements (both in exterior and interior), and special features. Measured drawings of the resource may also be required. The HPC shall determine on a case-by-case basis the extent of documentation required and the parties responsible for producing such documentation. The documentation shall be submitted to the HPC and become a permanent record of the Town of Beaufort.

10.1.3. Salvage architectural features and building materials for reuse or study. Contact antique dealers and used building supply establishments to arrange for removal. Consider donations of items to interested non-profit organizations or museums or the NC-SHPO.

10.1.4. Minimize ground-disturbing activities during demolition to avoid damage to potential unknown Archaeological resources.

10.1.5. Retain mature trees on site.

10.1.6. Clean the site thoroughly of all building debris and leave the lot properly graded and seeded.

THEREFORE, IT IS ORDERED based on the application submitted, the testimony given during the evidentiary hearing and the foregoing findings of fact, the HPC concludes that the proposed project is congruous with the special character of the Historic District as a whole and that a Certificate of Appropriateness be **ISSUED** for CASE # 23-29 310 ½ ORANGE STREET– DEMOLISH HOUSE AND SHED.

This the 7th day of November, 2023

\_\_\_\_\_  
Joyce McCune, Chair  
Beaufort Historic Preservation Commission

NOTE: If you are dissatisfied with the decision of this Board, an appeal may be taken to the Beaufort Board of Adjustment within 30 days after the date this order is served on you.



Town of Beaufort  
701 Front St. • P.O. Box 390 • Beaufort, N.C. 28516  
252-728-2141 • 252-728-3982 fax  
[www.beaufortnc.org](http://www.beaufortnc.org)

November 7, 2023

Bruce & Margaret Swartz  
304 Roslyn Road  
Richmond, VA 23226

RE: Case # 23-28 318 Orange Street – Addition to rear yard cottage

Dear Mr. & Mrs. Swartz:

Beaufort's Historic Preservation Commission wishes to thank you for your recent application for a Certificate of Appropriateness regarding the property referenced above which is in the Town's Historic District. We appreciate you taking the time to come before the Commission, as well as your willingness to work with us to preserve the distinctive character of Beaufort. Your commitment will help ensure the many historic and cultural resources that we enjoy today will be preserved for future generations.

You have been issued a Certificate of Appropriateness for your project as specified on the enclosed certificate. Please read it carefully. As you proceed with your project, you must comply with all the specifications stated, including provisions in the relevant Historic District Guidelines enumerated on the certificate. Please note the COA must be visibly displayed at the site during the entire duration of the project. Also note that a building permit with the Town may be needed depending on the scope of the work.

Your certificate is valid for the work which must begin within six (6) months from the date of issuance of the COA by the Commission and must be completed no later than one year thereafter. An extension of the COA can be granted upon the Town receiving a written request from the applicant prior to the application expiration date. An extension may only be granted once for a time period of six additional months if the work has been started but not completed within the one-year validation period. Upon completion of your project please contact our office in case an inspection of the project is required.

Thank you for the thought and care that you have dedicated to your project. Your contribution to the preservation of Beaufort's Historic District is greatly appreciated.

Sincerely,

Joyce McCune, Chair  
Beaufort Historic Preservation Commission

Enclosed: COA Certificate



TOWN OF BEAUFORT, NC  
ORDER GRANTING A CERTIFICATE OF APPROPRIATENESS

The Historic Preservation Commission for the Town of Beaufort, N.C. (“HPC”), having held an evidentiary hearing on October 3, 2023 to consider a Certificate of Appropriateness (“COA”) application submitted by Bruce & Margaret Swartz for **CASE # 23-28 318 ORANGE STREET – ADDITION TO REAR YARD COTTAGE** and having heard all of the evidence, testimony, and arguments presented during the evidentiary hearing on this item and having the material(s) submitted to the HPC from the applicant, makes the following CONCLUSION:

Based upon the testimony, evidence, and record before the HPC on October 3, 2023, we find that the application submitted meets the following design standards under the Design Guidelines for the Beaufort Historic District & Landmarks [revised 2008]:

*Roof Guidelines*

6.1.3 New roofing materials should be compatible with either the existing or original roofing material. Match the historic material as closely as possible in color, shape, size, and texture. Asphalt or fiberglass - asphalt shingles are acceptable substitutes for standing-seam tin, wood shingles, or metal shingles. Any distinctive patterns of shingles or slates shall be retained and/or replicated exactly. Galvanized standing - seam with a large “agricultural” ridge, usually for ventilation, is not acceptable in the historic district. Instead, use standing seam metal with a crimped edge.

6.1.7 Ridge vents, where needed, shall be of the low-profile type and shall not diminish the original design of the roof or destroy any character-defining architectural details. Other vents, such as gable vents and roof-mounted vents, should be installed so as not to be visible from the public view where possible. In the event that they must be visible, they should be installed to respect the architectural details and character of the subject building.

*Window and Door Guidelines*

6.4.7. New windows must match original in overall size and opening area and should have three dimensional muntins with either true divided lights (TDL) or three-dimensional grilles on both the interior and exterior sides (SDL). Snap-in grilles or grilles between glass are not appropriate for windows visible from public view.

6.4.10. New window and door openings shall not alter the historic character of the building or cause damage to historic materials or other significant architectural features. They must be detailed and sized to be compatible with the existing structure.

*Wood Siding, Trim, and Ornament Guidelines*

6.2.11. The use of fiber cement siding may be approved for new structures, non-historic structures, and additions to historic structures not visible from public streets or waterways.

THEREFORE, IT IS ORDERED based on the application submitted, the testimony given during the evidentiary hearing and the foregoing findings of fact, the HPC concludes that the proposed project is congruous with the special character of the Historic District as a whole and that a Certificate of Appropriateness be **ISSUED** for Case # 23-28 318 Orange Street – Addition to rear yard cottage.

This the 7<sup>th</sup> day of November, 2023

---

Joyce McCune, Chair  
Beaufort Historic Preservation Commission

NOTE: If you are dissatisfied with the decision of this Board, an appeal may be taken to the Beaufort Board of Adjustment within 30 days after the date this order is served on you.



Town of Beaufort  
701 Front St. • P.O. Box 390 • Beaufort, N.C. 28516  
252-728-2141 • 252-728-3982 fax  
[www.beaufortnc.org](http://www.beaufortnc.org)

November 7, 2023

Hunter Young, Contractor  
PO Box 2448  
Beaufort, NC 28516

RE: Case # 23-27 505 Front Street – Exterior Lighting

Dear Mr. Young:

Beaufort's Historic Preservation Commission wishes to thank you for your recent application for a Certificate of Appropriateness regarding the property referenced above which is in the Town's Historic District. We appreciate you taking the time to come before the Commission, as well as your willingness to work with us to preserve the distinctive character of Beaufort. Your commitment will help ensure the many historic and cultural resources that we enjoy today will be preserved for future generations.

The Beaufort Historic Preservation Commission conducted an evidentiary hearing on your application. Unfortunately, your application for Certificate of Appropriateness for your project as specified in the enclosed order has been denied. You have the right to resubmit this COA application, including in the event that you decide to and are granted approval to replace the exterior lighting consistent with the Design Guidelines for the Beaufort Historic District.

As stated in the Town's Land Development Ordinance, an appeal may be taken to the Board of Adjustment from the Historic Preservation Commission's actions in granting or denying any application for a Certificate of Appropriateness. Appeals may be taken to the Board of Adjustment by any aggrieved party and shall be taken within 30 days after the decision of the Historic Preservation Commission is signed by its Chairman and entered into the records of the Commission. You may call the Planning and Inspections Office at (252) 728-2142 to receive further details on this appeal process.

Thank you for the thought and care that you have dedicated to your project. Your contribution to the preservation of Beaufort's Historic District is greatly appreciated.

Sincerely,

Joyce McCune, Chair  
Beaufort Historic Preservation Commission

Enclosed: COA Certificate  
CC: Scott and Donna Brickell

Mayor Sharon Harker  
Commissioner John Hagle • Commissioner Marianna Hollinshed  
Commissioner Bucky Oliver • Commissioner [redacted] in Cooper • Commissioner Bob Terwilliger  
Town Manager [redacted] Todd Clark





TOWN OF BEAUFORT, NC  
ORDER GRANTING A CERTIFICATE OF APPROPRIATENESS

The Historic Preservation Commission for the Town of Beaufort, N.C. (“HPC”), having held an evidentiary hearing on October 3, 2023 to consider a Certificate of Appropriateness (“COA”) application submitted by Hunter Young, Contractor for **CASE # 23-27 505 FRONT STREET – EXTERIOR LIGHTING** and having heard all of the evidence, testimony, and arguments presented during the evidentiary hearing on this item and having the material(s) submitted to the HPC from the applicant, makes the following CONCLUSION:

Based upon the testimony, evidence and record before the HPC, we find that the application submitted does **not** meet the following design standards under the Design Guidelines for the Beaufort Historic District & Landmarks. [revised 2008]

8.4.1. Unless original fixtures already exist, choose fixtures that are simple and unobtrusive and complement the building or site.

8.4.2. Choose lighting sources that generate a soft white light instead of a more intensive yellow or orange light. Metal halide bulbs will achieve the desired effect instead of sodium vapor or fluorescent light sources.

8.4.3. Avoid placing fixtures in areas that will obscure or damage character-defining architectural elements or site features.

THEREFORE, IT IS ORDERED based on the application submitted, the testimony given during the evidentiary hearing and the foregoing findings of fact, the HPC concludes that the proposed project is not congruous with the special character of the Historic District as a whole and that a Certificate of Appropriateness be **DENIED** for Case # 23-27 505 Front Street – Exterior Lighting.

This the 7<sup>th</sup> day of November, 2023

\_\_\_\_\_  
Joyce McCune, Chair  
Beaufort Historic Preservation Commission

NOTE: If you are dissatisfied with the decision of this Board, an appeal may be taken to the Beaufort Board of Adjustment within 30 days after the date this order is served on you.



**Town of Beaufort, NC**

701 Front St. - P.O. Box 390 - Beaufort, N.C. 28516  
252-728-2141 - 252-728-3982 fax - www.beaufortnc.org

**Town of Beaufort Historic Preservation Commission Regular Meeting  
6:00 PM Tuesday, November 7, 2023 – 614 Broad Street – Train Depot**

---

**AGENDA CATEGORY:** Old Business  
**SUBJECT:** Case # 23-30 107 Sunset Lane – Fencing & Paves

**BRIEF SUMMARY:**

Application Update – Staff reviewed the application with the Town Attorneys, who could not verify from a preliminary title review that the Applicant is the owner of record of the 10’ wide drive where the proposed pavers are planned. Accordingly, and as announced during the October HPC meeting, the Applicant was required to either present evidence of ownership of the 10’ drive or present evidence of the consent of the owner of the drive (if other than the Applicant) to the portion of this application regarding the pavers.

The Applicant has since withdrawn the portion of the application regarding the 10’ driveway and requested pavers.

**REQUESTED ACTION:**

Conduct Quasi- Judicial Hearing

**EXPECTED LENGTH OF PRESENTATION:**

10 Minutes

**SUBMITTED BY:**

Kyle Garner, AICP

**BUDGET AMENDMENT REQUIRED:**

N/A



# BHPC STAFF REPORT



**To:** BHPC Members  
**From:** Kyle Garner, AICP  
**Date:** October 31, 2023  
**Case No.** 23-30

**Request:** Install fencing at 107 Sunset Lane  
**Applicant:** Victor Flow  
 18 Graylyn Place Court  
 Winston Salem, NC 27106

**Property Information:**

Owners: Victor Flow  
 Location: 107 Sunset Lane  
 PIN#: 730617014131000

**Project Information:** **Application Update – Staff reviewed the application with the Town Attorneys, who could not verify from a preliminary title review that the Applicant is the owner of record of the 10’ wide drive where the proposed pavers are planned. Accordingly, and as announced during the October HPC meeting, the Applicant was required to either present evidence of ownership of the 10’ drive or present evidence of the consent of the owner of the drive (if other than the Applicant) to the portion of this application regarding the pavers.**

**The Applicant has since withdrawn the portion of the application regarding the 10’ driveway and requested pavers.**

**Proposed work:**

- Install 6’-tall white privacy fence along west property line.
- Install 3’-tall white picket fence along Sunset Lane property line and along driveway.
- Replace brick runner driveway with 10’-wide paver drive. (**Application withdrawn**)

**Material:**

- Wooden picket fence
- Privacy fence (wood)
- Belguard driveway pavers, Dublin Cobble style, Savannah color (**Application withdrawn.**)

---

Color:

- White fencing

### Fences and Walls Guidelines

821. Design new fences that are compatible with the associated building, site and streetscape in height, proportion, scale, color, texture, material, and design. Substitute fence materials are not allowed along front or visible side property lines in the historic district. Fence types such as wire, hurricane, chain-link, vinyl, corrugated metal, stockade, and wooden post and rail are not allowed in public view.
822. Fences shall not exceed a height of four (4) feet in front yards and other areas of primary visual concern. Fences at rear yards and other areas not readily seen from the public view may be up to six (6) feet high. The transition between low front fences and higher rear fences should be made as far to the rear of the enclosed structure or yard as possible, and no more than half the depth of the yard forward of the principal structure. Avoid attaching a portion of the fence to a building because of possible termite damage.

# Case # 23-30 107 Sunset Lane - Fencing & Pavers

1.

**Legend**

- NCHPOpoints
- Tax\_Parcel\_Data

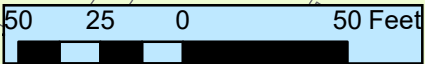
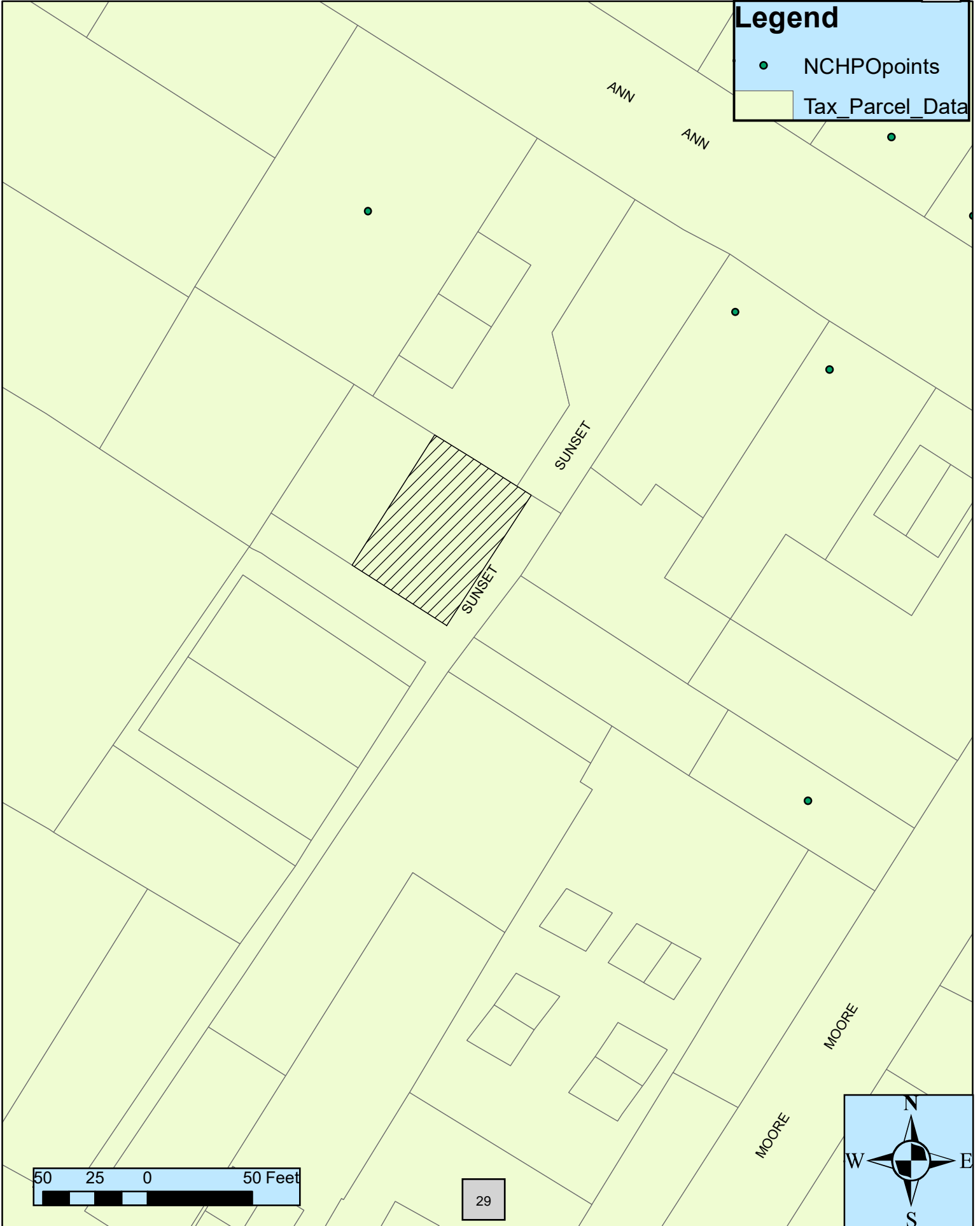

29

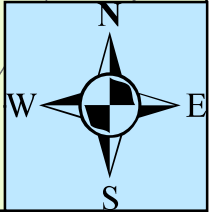

Mailing Addresses of Property Owners  
Adjacent to 107 Sunset Lane

<b>OWNER</b>	<b>MAIL_ADD</b>	<b>MAIL_CITY</b>	<b>MAIL_STATE</b>	<b>MAIL_ZI5</b>
FLOW VICTOR ETUX	18 GRAYLYN PLACE CT	WINSTON SALEM	NC	27106
JOHN & JOSEPH LLC	325 FRONT STREET	BEAUFORT	NC	28516
FROBOSE FREDERICK A ETUX KELL	1608 PINECREST ROAD	ROCKY MOUNT	NC	27803
BOLLINGER CLAY BELIN ETUX ETAL	4600 HICKORY NUT RIDGE RD	GRANITE FALLS	NC	28630
ASKEY BARBARA LEE TRUSTEE	182 TRANKILO STREET APT 604	TAMUNING	GUAM	96913
REVELS RAY V JR	120 ANN STREET	BEAUFORT	NC	28516
MOORE MICHAEL A ETAL WILLIAM M	113 MOORE STREET	BEAUFORT	NC	28516
CANDLEWOOD INVESTMENTS LLC	PO BOX K	ROCKY MOUNT	NC	27804

# CERTIFICATE OF APPROPRIATENESS APPLICATION FOR PROJECTS WITHIN THE BEAUFORT HISTORIC DISTRICT



### Instructions:

Please complete the application below and include all attachments as noted on page 2 of this application along with a **\$250.00 application fee** and return to the Beaufort Town Hall; 701 Front Street or P.O. Box 390, Beaufort, N.C. 28516. Incomplete applications will not be processed and **will be** returned to the applicant. Applications must be deemed complete and accepted before the submittal date. Please contact Town Hall at 252-728-2142 if there are any questions.

### APPLICANT/OWNER INFORMATION

*Please print!*

Applicant Name: Victor I. Flow Jr. By Margaret K. Chalk, AIA, NCARB

Applicant Address: 18 Graylyn Place Court, Winston Salem, NC 27106

Business Phone: 336-813-2555 Email/Cell: vicflow1214@AOL.com

Property Owner Name: Victor I. Flow Jr.

Address of Property: 107 Sunset Lane, Beaufort, NC 28516

Phone Number: 336-813-2555 Email/Cell: vicflow1214@AOL.com

### PROJECT INFORMATION

Detailed description of the Proposed Project (*please attach additional pages if necessary*):

Install 6' high white wood privacy fencing along west property line.

Install white wood picket fencing along Sunset Lane and a portion of South property line.

Pave 13' X 50' drive with Belguard 'Dublin Cobble,' Savannah color, to match owners's drives at 97-99 Sunset Lane (next door)

See attached Site Plan.

Estimated Cost of Project: \$ 25,000.00

Year House Built: Unknown

Margaret K. Chalk  
Applicant Signature

09.08.2023  
Date

Margaret K. Chalk, AIA, NCARB, Architect (252-726-3099). mkcarchitect@ec.rr.com

Victor I. Flow Jr.  
Property Owner Signature (if different than above)  
Victor I. Flow Jr., Owner

9-9-23  
Date

*An application fee of \$250.00, either in cash, money order, or check made payable to the "Town of Beaufort" must accompany this application (a credit or debit card payment can be made in person at Town Hall). The complete application, payment, and supporting material must be received by Town Staff by the posted submittal dates noted on the Historic Preservation's calendar found on the Town's website at [www.beaufortnc.org](http://www.beaufortnc.org). The Commission meets regularly on the first Tuesday of the month unless it is a holiday.*

### OFFICE USE ONLY

Received by: \_\_\_\_\_

Reviewed for Completeness: \_\_\_\_\_

Date: \_\_\_\_\_

Deemed Completed and Accepted: \_\_\_\_\_

# REQUIRED ATTACHMENTS FOR A CERTIFICATE OF APPROPRIATENESS (COA)

*Please provide the following along with this checklist form, with the COA application:*

## 1. Items required for ALL projects:

- A list of all Design Guidelines that apply to the application and a description of how proposed changes are consistent with the *Design Guidelines for the Beaufort Historic District & Landmarks*, which can be found at <https://www.beaufortnc.org/bc-hpc/page/design-guidelines-beaufort-historic-district-landmarks>
- A list of all adjacent property owners (with mailing addresses).
- Photographs of the streetscape, the site, and existing buildings to be impacted.
- A site plan showing dimensions of both existing and proposed conditions.
- A description of all building and/or landscaping materials (such as siding, roofing, windows, doors, signs, planting materials, etc.).

## 2. Items required as applicable to project:

- A description of any planned demolition. Chain link fence at West property line.
- An indication of all trees to be replaced and/or removed. None.
- A landscaping plan indicating major planting materials.
- Exterior paint color sample/color swatch(s) for projects involving any change of exterior paint color(s) only. Sherwin Williams Super Paint 'Super White' - Sample attached.
- All types of building material samples. Belguard Dublin Cobble 'Savannah' pavers - Spec Sheet attached.
- If a project involves the reconstruction of an earlier feature of a historic structure, documentation of the prior existence of such feature.

## 3. Additional items required (only) for new Signage:

- A drawing or true likeness of the new sign indicating the dimensions of the sign (and any supporting post or hanging apparatus if applicable). The lettering style and colors of the sign should also be on the drawing or likeness.
- A paint sample/color swatch of all color(s) to be used both on the sign and on the post or hanging apparatus if applicable.

4. At least **one set of materials, in color**, that are to be evaluated by the Commission should be submitted with the application. An electronic or digital file of the work should also be submitted. Please contact Town Staff to see what electronic or digital file can be submitted.

5. The applicant or a representative for the applicant **must be present at the meeting** for action to be taken on the application. If it is not possible for the applicant or their representative to be present at the assigned meeting, please contact Town Staff as soon as possible.

*A COA is valid for a period of six (6) months and may be renewed for an additional six months via written request to Town Staff from the applicant (please state all reasons why the extension is needed). If work has not begun or a building permit for the project has not been obtained within the six-month period, the COA is deemed invalid. The COA is considered issued once the Commission approves the application at their meeting.*

*If there are questions regarding what should or should not be included with this application, please contact Town Staff at 252-728-2142 or at [k.garner@beaufortnc.org](mailto:k.garner@beaufortnc.org).*



## Fences and Walls Guidelines

**Retain 8.2.1.** and preserve historic fence and wall material wherever possible. If replacement is necessary, use new material that matches the historic material in composition, size, shape, color, pattern and texture.

**No Historic Fence or wall materials exist on this property.**

**8.2.2.** Design new fences that are compatible with the associated building, site and streetscape in height, proportion, scale, color, texture, material and design. Substitute fence materials are not allowed along front or visible side property lines in the historic district. Fence types such as wire, hurricane, chain-link, vinyl, corrugated metal, stockade, and wooden post and rail are not allowed in public view.

**New fencing along Sunset Lane edge will be white wood pickets to match owners' adjoining property. A white wood privacy fence will be constructed along the west property line, and is in the back of the property, not on the street. See Site Plan for details and elevation drawing of fencing.**

**8.2.3.** Fences shall not exceed a height of four (4) feet in front yards and other areas of primary visual concern. Fences at rear yards and other areas not readily seen from the public view may be up to six (6) feet high. The transition between low front fences and higher rear fences should be made as far to the rear of the enclosed structure or yard as possible, and no more than half the depth of the yard forward of the principal structure. Avoid attaching a portion of the fence to a building because of possible termite damage.

**New white wood fencing will be 36" (or less), on the street, and 6' at the back (west) property line. The transition from low to high fencing will occur on the back and side corner of the property – see Site Plan. Fencing will be attached to fence posts, not to buildings.**

**8.2.4.** Historic retaining walls should be preserved. New low walls are appropriate only where a sharp change in grade exists, and shall not exceed a height of two (2) feet. Such walls should be constructed of brick or concrete block covered with a true sand-finish stucco.

**There are no existing Historic retaining walls on this property. No new retaining walls are planned on this property.**

**8.2.5.** The use of false historical details or other non-original architectural embellishments on existing fences is not appropriate.

**No such detailing is planned, not will any be applied. See fence elevation drawings on Site Plan.**

**8.2.6.** Use a combination of fences and plantings to screen parking lots. To provide adequate visibility for drivers entering and leaving, the fence should not exceed a height of three (3) feet at the street/sidewalk edge. (SEE OFF-STREET PARKING GUIDELINES for more details)

**No parking lot is planned. Access lane is screened by mature plant materials which are remaining in place on site.**

**8.2.7.** No contemporary or utilitarian fence materials are planned. Existing chain link fence on west property line will be removed to allow for construction of the new fence.

### Off-street Parking Guidelines

**Locate new parking** 8.5.1. lots and driveways in the historic district as unobtrusively as possible. Parking lots consisting of large expanses of concrete or asphalt with little planting or other screening are not appropriate.

No parking lot is planned for this property. The new access lane (driveway) will be pavers at the South Edge of the property. See Site Plan and material submittals.

8.5.2. Proposals for new parking lots or off-street parking areas should be accompanied by scaled site plans, including all proposed landscape and ground cover changes and information on proposed lighting types, placement, and intensity.

See attached scaled Site Plan. No lighting is planned, nor are changes planned to be made to the mature landscaping.

8.5.3. Site new parking areas in interior or rear lot locations where possible.

No new parking area is planned.

8.5.4. Avoid removing trees and other landscape elements that contribute to the historic character of a site.

No trees will be removed. Mature Landscaping is preserved.

8.5.5. Integrate pedestrian scale lighting into parking areas to avoid excessive glare and illumination to adjoining properties. See EXTERIOR LIGHTING guidelines and the Beaufort Zoning Ordinance for further details on lighting standards.

No lighting is planned.

8.5.6. Incorporate existing mature trees into new parking areas. Avoid the placement of impervious surface materials such as asphalt and concrete in areas below the canopy crown of the tree. Use turf stone, gravel, marl, or other pervious materials in these areas.

See Site Plan.

8.5.7. Use paving materials that were traditionally used on surface parking areas and driveways on the surrounding block or street. Gravel, marl, crushed shells, asphalt, and concrete are typical parking lot treatments, while grass, gravel or concrete runners with a grassy median, brick, and marl are typical driveway treatments. Use bricks, stone, or metal to contain loose paving materials. Landscaping timbers, railroad ties, and concrete or plastic edging are not allowed.

The Belgard Dublin Cobble ‘Savannah’ color pavers submitted for review, give the appearance of stone, and match adjacent driveways.

Adjacent Property Owners of Victor & Rodgersyn Flow

107 Sunset Lane, Beaufort, NC

Parcel No.: 730617014131000

99 Sunset Lane, Beaufort, NC

Parcel No.: 730617013074000

Flow, Victor Ivan Jr.

18 Graylyn Place Court

Winston Salem, NC 27106

Alley way

Parcel No.: 730617013077000

Sunset Lane Townhouses

18 Graylyn Place Court

Winston Salem, NC 27106

Vic Flow

105 Sunset Lane, Beaufort, NC

Parcel No.: 730617014104000

Askey, Barbara Lee Trustee

182 Trankilo Street #604

Tamuning, Guam 96913

120 Ann Street, Beaufort, NC

Parcel No.: 730617014296000

Bollinger, Clay Belin

4600 Hickory Nut Ridge Road

Granite Falls, NC 28630

Rick Monaco & David Bradley

120 Ann Street, Beaufort, NC

Parcel No.: 730617015220000

Revels, Ray V. Jr.

120 Ann Street

Beaufort, NC 28516

124 Sunset Lane, Beaufort, NC

Parcel No.: 730617015110000

John & Joseph LLC

325 Front Street

Beaufort, NC 28516

**122 Sunset Lane, Beaufort, NC**

Parcel No.: 73061701**5033**000  
Moore, Michael A & William M.  
113 Moore Street  
Beaufort, NC 28516

Jerry Wordsworth

**Alley way**

Parcel No.: 73061701**4083**000  
Candlewood Investments LLC  
PO Box K  
Rocky Mount, NC 27804

Jerry Wordsworth

**100 Sunset Lane**

Parcel No.: 73061701**4925**000 (Alley way)  
Sunset Lane Townhouses  
18 Graylyn Place Court  
Winston Salem, NC 27106

Jerry Wordsworth





SHERWIN-WILLIAMS.

# Take on the weather elements with SuperPaint® Exterior Acrylic Latex

Color: Super White  
Low-Lustre



SuperPaint® Exterior Acrylic Latex is designed to stand up beautifully to harsh weather.



Weather resistant



Outstanding adhesion



Reliable protection



Open your smartphone camera and scan over the code to learn more about the benefits of SuperPaint® Exterior Acrylic Latex. ▶





# DUBLIN COBBLE® PAVER



PRICING

\$\$

[\(HTTPS://WWW.BELGARD.COM/COLLECTION/HERITAGE/\)](https://www.belgard.com/collection/heritage/)

A true classic, its gently distressed surface and antiqued edges whisper quiet, timeless sophistication. Smaller than Bergerac and featuring a wide array of shapes, Dublin Cobble® creates a casually elegant, time-worn look recalling the hand-laid stone of centuries-old Mediterranean villas.

## Features & Benefits

- Gently distressed surfaces and antiqued edges
- Exceptional stability and durability
- Wide range of natural color blends
- ~~Belgard~~ variety of shapes and size

\*All colors and/or products may not be available in all areas. Please inquire for availability and special order options.

## COLORS



ARCTIC

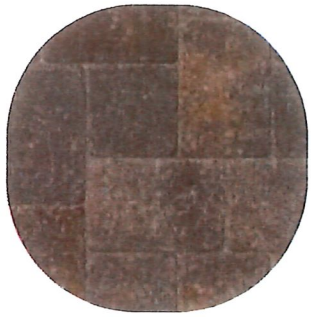

ARDENNES



FOSSIL

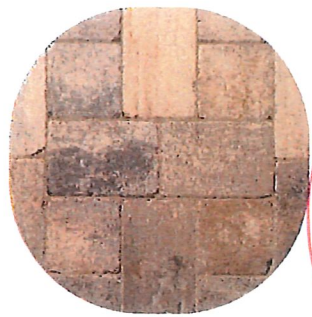

HATTERAS

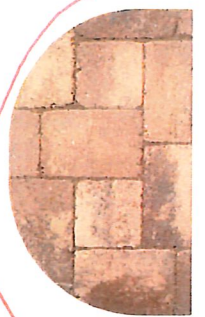

SAVANNA

## SPECS

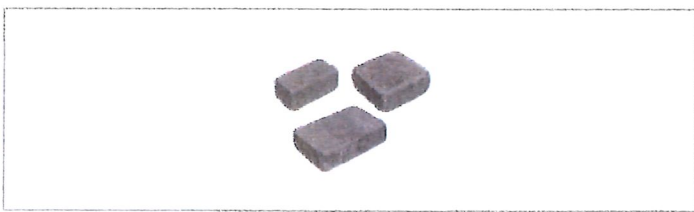

**3pc Modular**  
 3 x 6 x 2 3/8  
 6 x 6 x 2 3/8  
 6 x 9 x 2 3/8



**Border Unit**  
 6 x 9 x 2 3/8

FOR BEST RESULTS ENTER THE ZIP CODE WHERE YOUR PROJECT IS LOCATED.

Belgard products are manufactured regionally.

# DUBLIN COBBLE® PAVER

HERITAGE([HTTPS://WWW.BELGARD.COM/COLLECTION/HERITAGE/](https://www.belgard.com/collection/heritage/)  
 28557)



ARE YOU LOOKING FOR A PROFESSIONAL IN YOUR AREA?

Color Preview





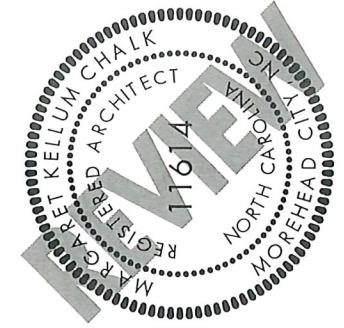
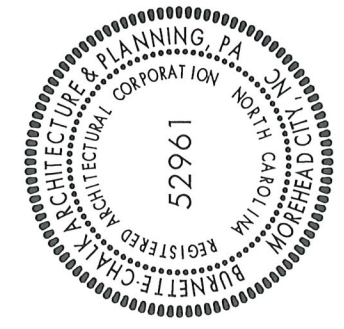

**BURNETTE • CHALK ARCHITECTURE & PLANNING, P.A.**  
105 BANKS STREET MOREHEAD CITY, NORTH CAROLINA 28557 252-726-5387 252-726-5099 FAX 252-726-5259 INFO@BURNCHALK.COM

PROJECT FILE # 23008  
DRAWN BY MKC/JAG  
PHASE: SD  
DATE: 08 SEPT 2023

VICTOR J. FLOW, JR.  
107 SUNSET LANE  
BEAUFORT, NORTH CAROLINA 28516

SITE PLAN  
COA APPLICATION

C101

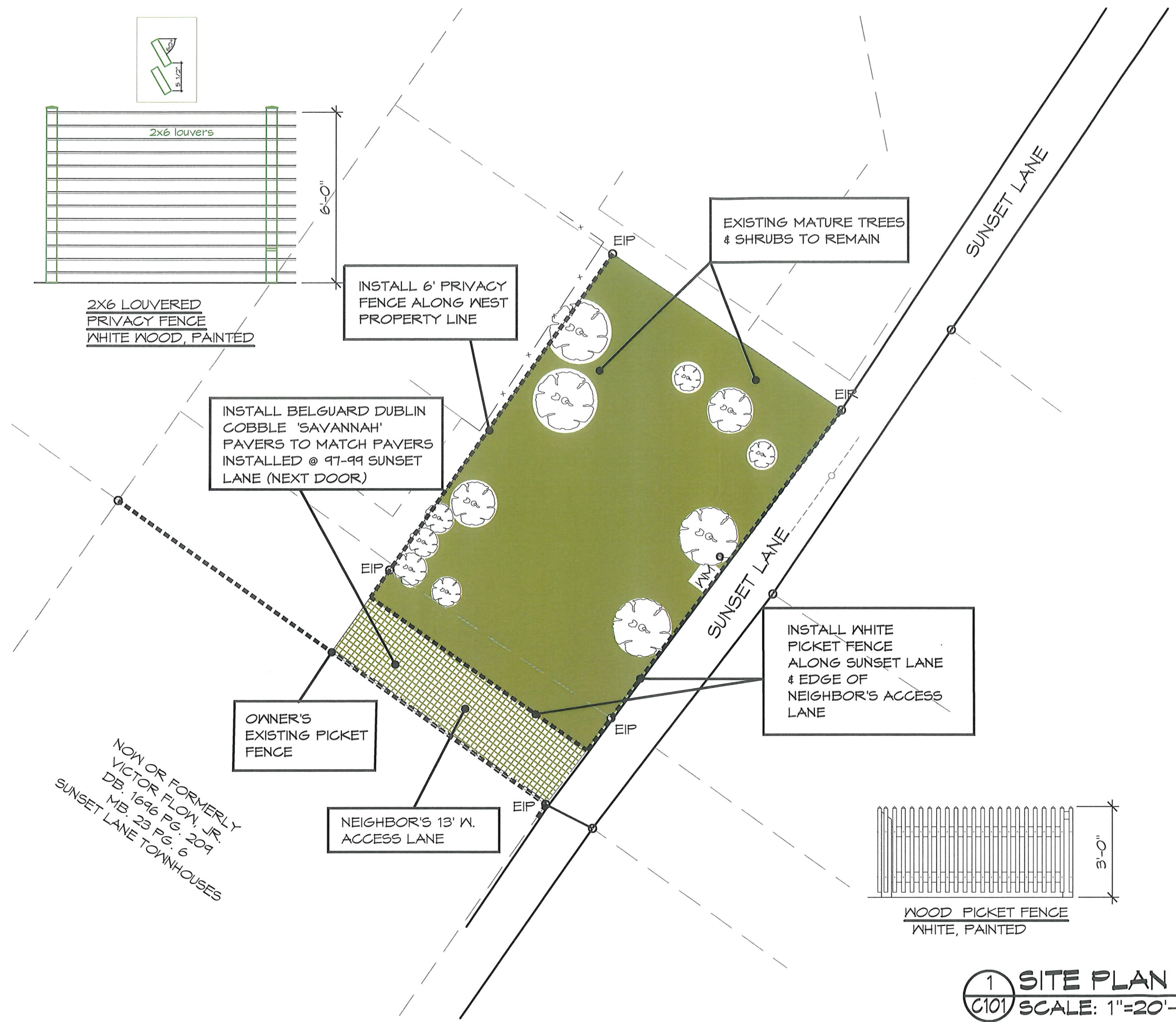

NOT OR FORMERLY  
VICTOR FLOW, JR.  
DB. 1696 PG. 209  
MB. 23 PG. 6  
SUNSET LANE TOWNHOUSES

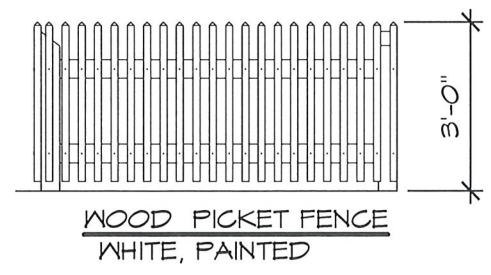

WOOD PICKET FENCE  
WHITE, PAINTED

1 SITE PLAN  
C101 SCALE: 1"=20'-0"

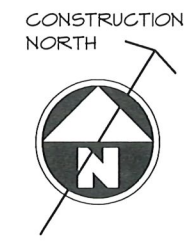

**PROGRESS SET**

\\BAPSERVER\Data\acaddwg\23008 Flow Residence - 107 Sunset\Beaufort Historical Commission\DWG\Site Plan - 0005, COA Fence & Paving Application.dwg, C101, 9/9/2023 3:31:33 PM, LANIER, MP, C2004ex, PCL 6, 1:1



**Town of Beaufort, NC**

701 Front St. - P.O. Box 390 - Beaufort, N.C. 28516  
252-728-2141 - 252-728-3982 fax - www.beaufortnc.org

**Town of Beaufort Historic Preservation Commission Regular Meeting  
6:00 PM Tuesday, November 7, 2023 – 614 Broad Street – Train Depot**

---

**AGENDA CATEGORY:** New Business

**SUBJECT:** Case # 23-31 120 & 120 A Craven Street - Paint, Porch & Lighting

**BRIEF SUMMARY:**

The owner wishes to paint the front door, paint the porch ceiling and add exterior lights beside the front door at 120 & 120 A Craven Street.

**REQUESTED ACTION:**

Conduct Quasi- Judicial Hearing

**EXPECTED LENGTH OF PRESENTATION:**

15 Minutes

**SUBMITTED BY:**

Kyle Garner

**BUDGET AMENDMENT REQUIRED:**

N/A



# BHPC STAFF REPORT



**To:** BHPC Members  
**From:** Kyle Garner, AICP  
**Date:** October 31, 2023  
**Case No.** 23-31

**Request:** To paint the front door, paint the porch ceiling and add exterior lights beside the front door.

**Applicant:** Dina Santoro  
 2603 One Iron Street  
 Morehead City, NC 28557

**Property Information:**

**Owners:** Dina Santoro  
**Location:** 120 & 120 A Craven Street  
**PIN#:** 730617107097000

**Project Information:** According to The Beaufort National Register Historic District Comprehensive Survey by M. Ruth Little, Ph.D. of 1997: 120 Craven Street, circa 1885. House. 1½-Story, 6-bay, side gable house with molded eave returns and a wide front shed wall dormer. Plain siding, 2 interior brick chimneys, 2/2 sash, and a hipped porch with turned posts, railing, spindle frieze, and sawn work brackets. House has two entrances, with Craftsman doors with transoms. Rear ell has engaged porch with chamfered posts and turned railing. A house of this general form appears on the 1885 Sanborn map. (SM)

**Proposed work:**

- Paint the front door, paint the porch ceiling, and add exterior lights beside the front door.

**Material:**

**Color:**

## Paint and Exterior Colors Guidelines

6.7.2. Determine the building’s style and period and consult with the HPC or reference sources for the most appropriate paint colors. Use paint colors that are appropriate for the style and period of the subject property and that accentuate the building’s architectural features.

## Exterior Lighting Guidelines

8.4.1. Unless original fixtures already exist, choose fixtures that are simple and unobtrusive and complement the building or site.

8.4.2. Choose lighting sources that generate a soft white light instead of a more intensive yellow or orange light. Metal halide bulbs will achieve the desired effect instead of sodium vapor or fluorescent light sources.

8.4.3. Avoid placing fixtures in areas that will obscure or damage character-defining architectural elements or site features.

8.4.5. All lighting should be directed toward the property for which it was intended and should not spill over onto adjacent properties.

**Legend**

- NCHPOpoints
- Tax\_Parcel\_Data

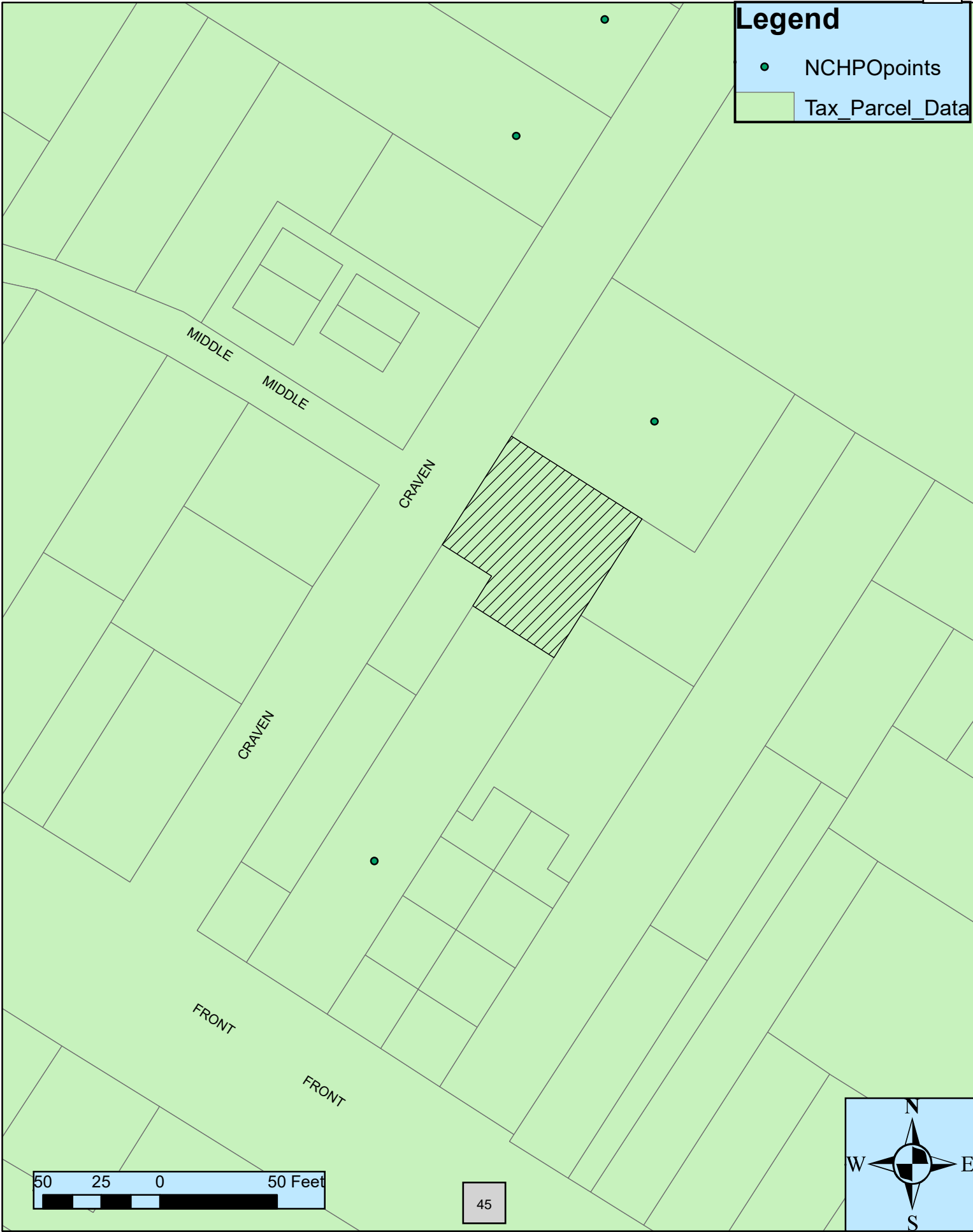

<u>OWNER</u>	<u>MAIL_HOU</u>	<u>MAIL_ST</u>	<u>MAIL_CITY</u>	<u>IL_ST</u>	<u>MAIL_ZI</u>	<u>MAIL_ADD2</u>
BEAUFORT FLATS LLC	608	ANN STREET	BEAUFORT	NC	1143 28516	
BRICKELL,SCOTT ETUX DONNA	2604	KITTRELL DRIVE	RALEIGH	NC	27608	
GREENBERG,BRENT ETUX SINDEE			BEAUFORT	NC	28516	PO BOX 27
HISTORIC HOLDINGS LP	2205	SAINT MARY'S ST	RALEIGH	NC	27608	
IRA SERVICES TRUST COMPANY	104	TAYLORS CREEK LN	BEAUFORT	NC	28516	
SANTORO,DINA CHARLENE TRUSTEE	2603	ONE IRON ST	MOREHEAD CITY	NC	4961 28557	

**CERTIFICATE OF APPROPRIATENESS APPLICATION  
FOR PROJECTS WITHIN THE BEAUFORT HISTORIC DISTRICT**



**Instructions:**

Please complete the application below and include all attachments as noted on page 2 of this application along with a **\$250.00 application fee** and return to the Beaufort Town Hall; 701 Front Street or P.O. Box 390, Beaufort, N.C. 28516. Incomplete applications will not be processed and **will be** returned to the applicant. Applications must be deemed complete and accepted before the submittal date. Please contact Town Hall at 252-728-2142 if there are any questions.

**APPLICANT/OWNER INFORMATION**

*Please print!*

Applicant Name: Dina Santoro  
Applicant Address: 2603 One Iron St, Morehead City 28557  
Business Phone: \_\_\_\_\_ Email/Cell: 252-725-0760  
Property Owner Name: Dina Santoro, Trustee  
Address of Property: 120/120A Craven St, Beaufort  
Phone Number: \_\_\_\_\_ Email/Cell: santoro6970@gmail.com

**PROJECT INFORMATION**

Detailed description of the Proposed Project (please attach additional pages if necessary):

Estimated Cost of Project: \$ 1,000.00      *Has been renovated last 1998*  
Year House Built: 19828  
Dina Santoro, Trustee      10/3/23  
Applicant Signature      Date

Property Owner Signature (if different than above)      Date

**An application fee of \$250.00, either in cash, money order, or check made payable to the "Town of Beaufort" must accompany this application (a credit or debit card payment can be made in person at Town Hall). The complete application, payment, and supporting material must be received by Town Staff by the posted submittal dates noted on the Historic Preservation's calendar found on the Town's website at [www.beaufortnc.org](http://www.beaufortnc.org). The Commission meets regularly on the first Tuesday of the month unless it is a holiday.**

**OFFICE USE ONLY**

Received by: \_\_\_\_\_ Reviewed for Completeness: \_\_\_\_\_  
Date: \_\_\_\_\_ Deemed Completed and Accepted: \_\_\_\_\_

## REQUIRED ATTACHMENTS FOR A CERTIFICATE OF APPROPRIATENESS (COA)

*Please provide the following along with this checklist form, with the COA application:*

### 1. Items required for ALL projects:

- A list of all Design Guidelines that apply to the application and a description of how proposed changes are consistent with the *Design Guidelines for the Beaufort Historic District & Landmarks*, which can be found at <https://www.beaufortnc.org/bc-hpc/page/design-guidelines-beaufort-historic-district-landmarks>
- A list of all adjacent property owners (with mailing addresses).
- Photographs of the streetscape, the site, and existing buildings to be impacted.
- A site plan showing dimensions of both existing and proposed conditions.  
*picture - before + light location*
- A description of all building and/or landscaping materials (such as siding, roofing, windows, doors, signs, planting materials, etc.).

### 2. Items required as applicable to project:

- A description of any planned demolition.
- An indication of all trees to be replaced and/or removed.
- A landscaping plan indicating major planting materials.
- Exterior paint color sample/color swatch(s) for projects involving any change of exterior paint color(s) only.
- All types of building material samples.
- If a project involves the reconstruction of an earlier feature of a historic structure, documentation of the prior existence of such feature.

### 3. Additional items required (only) for new Signage:

- A drawing or true likeness of the new sign indicating the dimensions of the sign (and any supporting post or hanging apparatus if applicable). The lettering style and colors of the sign should also be on the drawing or likeness.
- A paint sample/color swatch of all color(s) to be used both on the sign and on the post or hanging apparatus if applicable.

4. At least **one set of materials, in color**, that are to be evaluated by the Commission should be submitted with the application. An electronic or digital file of the work should also be submitted. Please contact Town Staff to see what electronic or digital file can be submitted.

5. The applicant or a representative for the applicant **must be present at the meeting** for action to be taken on the application. If it is not possible for the applicant or their representative to be present at the assigned meeting, please contact Town Staff as soon as possible.

*A COA is valid for a period of six (6) months and may be renewed for an additional six months via written request to Town Staff from the applicant (please state all reasons why the extension is needed). If work has not begun or a building permit for the project has not been obtained within the six-month period, the COA is deemed invalid. The COA is considered issued once the Commission approves the application at their meeting.*

*If there are questions regarding what should or should not be included with this application, please contact Town Staff at 252-728-2142 or at [k.garner@beaufortnc.org](mailto:k.garner@beaufortnc.org).*



COA application for 120/120 A Craven St., Beaufort  
Submitted by Dina Santoro

**List of Design Guidelines that apply**

**1. Paint and Exterior Colors Guidelines**

**6.7.2** color appropriate to building style and period  
Note: I believe this home was built in the Victorian Vernacular style. This home does not have its original front door. States, typically, walls are lighter, while trim and doors are a darker shade of varying colors. The porch ceiling, historically, is frequently painted light blue in color.

**2. Exterior Lighting**

**8.4.1** simple and complement the building  
Note: I believe the style, color and size are appropriate for and enhances this building. The homes closest to this home also have sconce lighting next to their front doors.

**8.4.2** soft white lighting will be used so as not to excessively illuminate the porch and should not bother neighbors. This sconce uses small candle shaped bulbs.

COA application for 120/120 A Craven St., Beaufort  
Submitted by Dina Santoro

**Proposed plan:**

1. Paint the front door a blueish gray/slate color. Currently, the color is a blueish green. This door and the current paint color are not original to this home.
2. Paint the wood slat porch ceiling a very light blue. The current color is white.
3. Add an electric powered sconce light to be mounted on the left side of the front door. The color is bronze. The style is a lantern with candle shaped lights. It's dimensions are approximately 18" H x 8" W x 9" D

120/120A Craven St, Beaufort  
currently existing:

2.

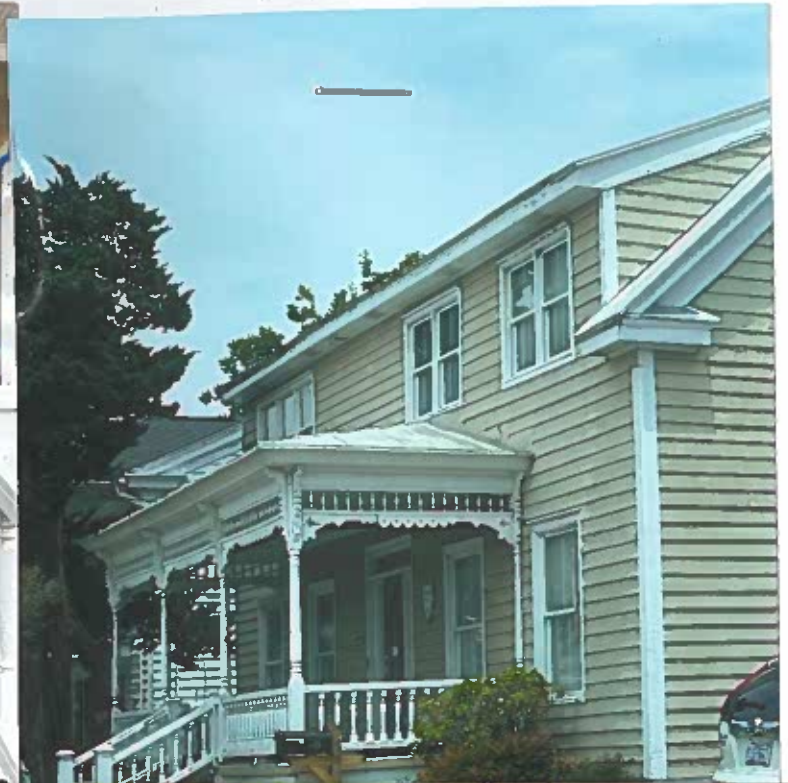

Proposed: ③ Sconce style + color →

① front door  
paint color

② porch ceiling  
paint color





**Town of Beaufort, NC**

701 Front St. - P.O. Box 390 - Beaufort, N.C. 28516  
252-728-2141 - 252-728-3982 fax - www.beaufortnc.org

**Town of Beaufort Historic Preservation Commission Regular Meeting  
6:00 PM Tuesday, November 7, 2023 – 614 Broad Street – Train Depot**

---

**AGENDA CATEGORY:** New Business  
**SUBJECT:** Case # 23-33 100 Sunset Lane - Fencing, Driveway & Exterior Lighting

**BRIEF SUMMARY:**

The applicant wishes to install fencing, pavers, landscaping, and exterior lighting at 100 Sunset Lane.

**REQUESTED ACTION:**

Conduct Quasi- Judicial Hearing

**EXPECTED LENGTH OF PRESENTATION:**

10 Minutes

**SUBMITTED BY:**

Kyle Garner, AICP

**BUDGET AMENDMENT REQUIRED:**

N/A



# BHPC STAFF REPORT



**To:** BHPC Members  
**From:** Kyle Garner, AICP  
**Date:** October 31, 2023  
**Case No.** 23-33

**Request:** Install fencing, pavers, landscaping, and exterior lighting at 100 Sunset Lane  
**Applicant:** Jay Horton (Filter Design Studio PLLC)  
 707 Bridges Street  
 Morehead City, NC 28557

**Property Information:**  
**Owners:** Sunset Lane Properties, LLC  
**Location:** 100 Sunset Lane  
**PIN#:** 730617004925000

**Project Information:** According to The Beaufort National Register Historic District Comprehensive Survey by M. Ruth Little, Ph.D. of 1997: 100 Sunset Lane, circa 1970. House. *2-Story*, front gable house with wood shake walls and 8/8 sash. NC Garage. c. 1970. *1-Story* wood-shingled garage. (***This structure was demolished before 2018***)  
  
 March 6, 2018, a COA was issued for a new structure for 100 “120 Sunset Lane”.

- Proposed work:**
- Install fencing.
  - Install new pavers.
  - Install exterior lighting & landscaping
  -

**Material:**

- See Application

**Color:**

- See Application

**Fences and Walls Guidelines**

8.2.2. Design new fences that are compatible with the associated building, site and streetscape in height, proportion, scale, color, texture, material, and design. Substitute fence materials are not allowed along front or visible side property lines in the historic district. Fence types such as wire, hurricane, chain-link, vinyl, corrugated metal, stockade, and wooden post and rail are not allowed in public view.

8.2.3. Fences shall not exceed a height of four (4) feet in front yards and other areas of primary visual concern. Fences at rear yards and other areas not readily seen from the public view may be up to six (6) feet high. The transition between low front fences and higher rear fences should be made as far to the rear of the enclosed structure or yard as possible, and no more than half the depth of the yard forward of the principal structure. Avoid attaching a portion of the fence to a building because of possible termite damage.

8.2.6. Use a combination of fences and plantings to screen parking lots. To provide adequate visibility for drivers entering and leaving, the fence should not exceed a height of three (3) feet at the street/sidewalk edge. (SEE OFF-STREET PARKING GUIDELINES for more details)

**Off-street Parking Guidelines**

8.5.1 Locate new parking lots and driveways in the historic district as unobtrusively as possible. Parking lots consisting of large expanses of concrete or asphalt with little planting or other screening are not appropriate.

8.5.2. Proposals for new parking lots or off-street parking areas should be accompanied by scaled site plans, including all proposed landscape and ground cover changes and information on proposed lighting types, placement, and intensity.

8.5.3. Site new parking areas in interior or rear lot locations where possible.

8.5.4. Avoid removing trees and other landscape elements that contribute to the historic character of a site.

8.5.5. Integrate pedestrian scale lighting into parking areas to avoid excessive glare and illumination to adjoining properties. See EXTERIOR LIGHTING guidelines and the Beaufort Zoning Ordinance for further details on lighting standards.

8.5.6. Incorporate existing mature trees into new parking areas. Avoid the placement of impervious surface materials such as asphalt and concrete in areas below the canopy crown of the tree. Use turf stone, gravel, marl, or other pervious materials in these areas.

8.5.7. Use paving materials that were traditionally used on surface parking areas and driveways on the surrounding block or street. Gravel, marl, crushed shells, asphalt, and concrete are typical parking lot treatments, while grass, gravel or concrete runners with a grassy median, brick, and marl are typical driveway treatments. Use bricks, stone, or metal to contain loose paving materials. Landscaping timbers, railroad ties, and concrete or plastic edging are not allowed.

### Landscaping Guidelines

8.1.1. Preserve and maintain historic public and private landscapes that contribute to the character of the historic district, including open spaces, streetscapes, and yards.

8.1.2. Preserve and maintain the individual components and historic features that contribute to Beaufort’s historic character, including mature trees, ornamental trees, and hedge rows.

8.1.4. Plant smaller trees species in the planting strips adjacent to public streets only if utility lines or other overhead obstructions exist. Use species such as crape myrtle, cedar, dogwood, redbud, Carolina cherry laurel and sweet bay magnolia.

8.1.6. Palms, banana trees and other tropical type landscape materials should not dominate the landscape palette. Sabal palms may be used as a minor landscape element. Likewise, any use of other tropical style plant materials that can be viewed from the public property should be limited to a minor complementary presence. Traditional plant materials including live oak trees, deciduous shade, and understory trees (service berry or dogwood) and broadleaf evergreen and deciduous shrubs should dominate the landscape.

8.1.7. Maintain the relationship between the mass/proportion of the building and open space within the context of the streetscape for new construction, additions, and landscape.

8.1.10. Contemporary edging or border materials, such as exposed landscape timbers, railroad ties, pre-cast concrete, plastic, or other substitute material borders are not appropriate in areas seen from the public view.

### Exterior Lighting Guidelines

8.4.1. Unless original fixtures already exist, choose fixtures that are simple and unobtrusive and complement the building or site.

8.4.2. Choose lighting sources that generate a soft white light instead of a more intensive yellow or orange light. Metal halide bulbs will achieve the desired effect instead of sodium vapor or fluorescent light sources.

8.4.3. Avoid placing fixtures in areas that will obscure or damage character-defining architectural elements or site features.

8.4.5. All lighting should be directed toward the property for which it was intended and should not spill over onto adjacent properties.

**Legend**

- NCHPOpoints
- Tax\_Parcel\_Data

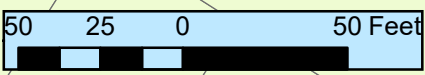

56

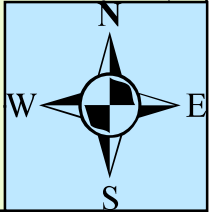



<u>OWNER</u>	<u>MAIL_HOU</u>	<u>MAIL_ST</u>	<u>MAIL_CITY</u>	<u>L ST</u>	<u>MAIL_ZI</u>	<u>MAIL_ADD2</u>
APPERSON,ZACHARY V ETAL			LA GRANGE	NC	28551	PO BOX 625
BEACON STREET BRADLEY LLC	3126	SUSSEX RD	RALEIGH	NC	27607	
BOWEN,MARY ELIZABETH WARD	109	GREENSVIEW DRIVE	CARY	NC	27518	
CANDLEWOOD INVESTMENTS LLC			ROCKY MOUNT	NC	27804	PO BOX K
COPLAND,JASON C ETAL	3156	ABINGDON PLACE	BURLINGTON	NC	27215	
MOORE,NANCY WASHINGTON	113	MOORE STREET	BEAUFORT	NC	2128 28516	

**CERTIFICATE OF APPROPRIATENESS APPLICATION  
FOR PROJECTS WITHIN THE BEAUFORT HISTORIC DISTRICT**



**Instructions:**

Please complete the application below and include all attachments as noted on page 2 of this application along with a **\$250.00 application fee** and return to the Beaufort Town Hall; 701 Front Street or P.O. Box 390, Beaufort, N.C. 28516. Incomplete applications will not be processed and **will be** returned to the applicant. Applications must be deemed complete and accepted before the submittal date. Please contact Town Hall at 252-728-2142 if there are any questions.

**APPLICANT/OWNER INFORMATION**

*Please print!*

Applicant Name: Jay Horton- Filter Design Studio PLLC

Applicant Address: 707 Bridges Street, Morehead City, NC 28557

Business Phone: 252-622-4119 Email/Cell: jay@filterdesignstudio.com

Property Owner Name: Sunset Lane Properties LLC

Address of Property: 100 Sunset Lane, Beaufort, NC 28512

Phone Number: \_\_\_\_\_ Email/Cell: \_\_\_\_\_

**PROJECT INFORMATION**

Detailed description of the Proposed Project (*please attach additional pages if necessary*):

A proposed historical Beaufort style white picket fence.

\*A better detailed description will be included in the narrative and will be attached to the application.

Estimated Cost of Project: \$ \$50,000

Year House Built: 2021

\_\_\_\_\_  
Applicant Signature

\_\_\_\_\_  
Date

\_\_\_\_\_  
Property Owner Signature (if different than above)

\_\_\_\_\_  
Date

*An application fee of \$250.00, either in cash, money order, or check made payable to the "Town of Beaufort" must accompany this application (a credit or debit card payment can be made in person at Town Hall). The complete application, payment, and supporting material must be received by Town Staff by the posted submittal dates noted on the Historic Preservation's calendar found on the Town's website at [www.beaufortnc.org](http://www.beaufortnc.org). The Commission meets regularly on the first Tuesday of the month unless it is a holiday.*

**OFFICE USE ONLY**

Received by: \_\_\_\_\_

Reviewed for Completeness: \_\_\_\_\_

Date: \_\_\_\_\_

58 Deemed Completed and Accepted: \_\_\_\_\_



HPC Application  
Certificate of Appropriateness  
Proposed Two-Story Addition

Applicant            Filter Design Studio PLLC  
Contractor

## Table of Contents

1. Certificate of Appropriateness
2. Scope of Work
3. Project Specifications
4. Guidelines
5. Adjacent Property Owners Information
6. Site Plan
7. Landscape Plan
8. Proposed Materials

## Project Description:

Design and construction of a white Beaufort NC style picket fence and the installation of Dublin Cobble Modular pavers for driveways and walkways, we aim to create an inviting, visually pleasing, and practical environment, one that compliments the site located in the Historic District.

The intent is to infuse the timeless elegance of the Beaufort, North Carolina style into the property. A white picket fence, emblematic of coastal heritage, will define the boundaries and add a sense of warmth and character. In addition, Dublin Cobble Modular pavers will grace the driveways and walkways, offering both durability and an inviting, old-world charm. Our vision encompasses a harmonious blend of form and function, transforming this property into a welcoming and visually captivating space.

## Project Specifications:

See drawings and comments within each applicable guideline below.

## Guidelines

### Paint and Exterior Colors Guidelines

**6.7.1. Repainting a building in the same color, including minor touch-up painting, and the cleaning of existing painted surfaces do not require a COA, nor does re-lettering a painted sign in the same color.**

Fence to be painted to match dwelling.

**7.3.3. Use materials in traditional ways. New materials should appear as if they were applied in a traditional manner so as to convey the same visual appearance as historically used and applied building materials.**

Materials will be used in traditional ways. New materials will appear as if they were applied in a traditional manner in order to convey the same visual appearance as historically used and applied building materials.

## Texture and Color

**7.5.1. Create in new construction a similar degree of texture that is found in contributing buildings in the historic district. Texture is the relief on a building surface that is achieved through use and interaction of a variety of building materials and shapes. Materials such as weatherboard siding, decorative fish-scale shingles, and beaded-board porch ceilings are examples of wooden architectural elements that have different physical and visual qualities and contribute to the “texture” of a building surface.**

New fence construction will provide a similar degree of texture that is found in contributing fences in the historic district.



## Form and Rhythm

### **7.6.1. Design new construction that reflects the basic shapes and forms on the block and in the historic district.**

The new fence construction will reflect basic Beaufort Style Picket Fence on block throughout the historic district..

## Landscaping

### **7.7.1. Retain and protect mature trees during construction.**

No damage is anticipated to mature trees during construction.

## Landscaping Guidelines

### **8.1.1. Preserve and maintain historic public and private landscapes that contribute to the character of the historic district, including open spaces, streetscapes, and yards.**

Proposed landscaping is Historically relevant and in keeping with the district

### **8.1.2. Preserve and maintain the individual components and historic features that contribute to Beaufort's historic character, including: mature trees, ornamental trees, and hedge rows.**

Existing trees will remain and proposed plantings to be in keeping with the district

### **8.1.3. Preserve and maintain mature street trees. When removal or replacement is necessary, replace with long lived tree species with large canopies that will provide a similar canopy and form as a street tree. Replacement tree species should be appropriate for the district. Suggested species include: oak, sycamore, pecan, maple, ginkgo (male only), Chinese elm, cedar (juniper) , hickory, Yaupon holly or American holly.**

No trees will be removed; evergreen hollies to be used as screen and Little Gem Magnolia to accent

### **8.1.4. Plant smaller trees species in the planting strips adjacent to public streets only if utility lines or other overhead obstructions exist. Use species such as crape myrtle, cedar, dogwood, redbud, Carolina cherry laurel and sweet bay magnolia.**

N/A

### **8.1.5. All new plant materials selected for replanting or new planting in publicly visible areas should complement as much as possible those found on the site and in the surrounding area of the district.**

See Planting Plan

### **8.1.6. Palms, banana trees and other tropical type landscape materials should not dominate the landscape palette. Sabal palms may be used as a minor landscape element. Likewise, any use of other tropical style plant materials that can be viewed from the public property should be limited to a minor complementary presence. Traditional plant materials including live oak trees, deciduous shade and understory trees (service berry or dogwood) and broadleaf evergreen and deciduous shrubs should dominate the landscape.**

See Planting Plan

### **8.1.7. Maintain the relationship between the mass/proportion of the building and open space within the context of the streetscape for new construction, additions and landscape.**

See Planting Plan

**8.1.14. Use a combination of fences and plantings to screen parking lots. To provide adequate visibility for drivers entering and leaving, screening should not exceed height of three (3) feet at the street/sidewalk edge. (SEE OFF STREET PARKING GUIDELINES for more details)**

See Planting Plan

## Fences and Walls Guidelines

**8.2.1. Retain and preserve historic fence and wall material wherever possible. If replacement is necessary, use new material that matches the historic material in composition, size, shape, color, pattern and texture.**

See Detail Shet

**8.2.2. Design new fences that are compatible with the associated building, site and streetscape in height, proportion, scale, color, texture, material and design. Substitute fence materials are not allowed along front or visible side property lines in the historic district. Fence types such as wire, hurricane, chain-link, vinyl, corrugated metal, stockade, and wooden post and rail are not allowed in public view.**

See Detail Sheet

**8.2.3. Fences shall not exceed a height of four (4) feet in front yards and other areas of primary visual concern. Fences at rear yards and other areas not readily seen from the public view may be up to six (6) feet high. The transition between low front fences and higher rear fences should be made as far to the rear of the enclosed structure or yard as possible, and no more than half the depth of the yard forward of the principal structure. Avoid attaching a portion of the fence to a building because of possible termite damage.**

See Detail Sheet

**8.2.6. Use a combination of fences and plantings to screen parking lots. To provide adequate visibility for drivers entering and leaving, the fence should not exceed a height of three (3) feet at the street/sidewalk edge. (SEE OFF-STREET PARKING GUIDELINES for more details)**

See Detail Sheet and Planting Plan

**8.2.7. Contemporary or utilitarian fence materials are not appropriate for fences in the public view. Inappropriate materials include: plastic, vinyl, chain link, wire, and all other modern materials. The use of modern fencing is permitted for rear yards only, in areas not seen from the public view, using vinyl-coated chain link (dark green or black), standard chain link or heavy wire (“hog wire”). Use plantings such as ivy, climbing roses, jasmines, or other vines to hide wire fences.**

Traditional fencing application proposed.

## Adjacent Property Owners

PARCEL NUMBER: 730617002865000  
 OWNER: LITTLEWOOD, GEORGE F ETUX PAGE  
 PHYSICAL ADDRESS: 113 FRONT ST  
 BEAUFORT  
 MAILING ADDRESS: 113 FRONT STREET  
 BEAUFORT NC 28516  
 LEGAL DESCRIPTION: L FRONT ST TOWN OF BEAUFORT  
 DEED REF: 1701-096  
 PLAT REFERENCE: -  
 NEIGHBORHOOD: 590005

PARCEL NUMBER: 730617001940000  
 OWNER: WOOTEN, WILLIAM B ETUX MARGARET  
 PHYSICAL ADDRESS: 105 FRONT ST  
 BEAUFORT  
 MAILING ADDRESS: 282 MCNAIR RD  
 TARBORO NC 27886  
 LEGAL DESCRIPTION: LOTS 1 4 UHF DEVELOPMENT GROUP  
 DEED REF: 1699-485  
 PLAT REFERENCE: 31-684  
 NEIGHBORHOOD: 590005

PARCEL NUMBER: 730617003925000  
 OWNER: FLOW, VICTOR IVAN JR  
 PHYSICAL ADDRESS: 95 SUNSET LN  
 BEAUFORT  
 MAILING ADDRESS: 18 GRAYLYN PLACE CT  
 WINSTON SALEM NC 27106  
 LEGAL DESCRIPTION: LOT SUNSET LANE TOWN OF BEAUFORT  
 DEED REF: 1706-030  
 PLAT REFERENCE: -  
 NEIGHBORHOOD: 590003

PARCEL NUMBER: 730617013077000  
OWNER: SUNSET LANE TOWNHOUSES  
PHYSICAL ADDRESS 0  
MAILING ADDRESS: 18 GRAYLYN PLACE CT  
WINSTON SALEM NC 27106  
LEGAL DESCRIPTION: COMMON AREA SUNSET LANE TOWNHS  
DEED REF: 1696-209  
PLAT REFERENCE: 23-6  
NEIGHBORHOOD: 590003

PARCEL NUMBER: 730617013060000  
OWNER: FLOW,VICTOR IVAN JR  
PHYSICAL ADDRESS 97 SUNSET LN  
BEAUFORT  
MAILING ADDRESS: 18 GRAYLYN PLACE CT  
WINSTON SALEM NC 27106  
LEGAL DESCRIPTION: L1 SUNSET LANE TOWNHOMES  
DEED REF: 1696-209  
PLAT REFERENCE: 23-6  
NEIGHBORHOOD: 590003

PARCEL NUMBER: 730617013074000  
OWNER: FLOW,VICTOR IVAN JR  
PHYSICAL ADDRESS 99 SUNSET LN  
BEAUFORT  
MAILING ADDRESS: 18 GRAYLYN PLACE CT  
WINSTON SALEM NC 27106  
LEGAL DESCRIPTION: L2 SUNSET LANE TOWNHOMES.  
DEED REF: 1696-209  
PLAT REFERENCE: 23-6  
NEIGHBORHOOD: 590003

PARCEL NUMBER: 730617014131000  
OWNER: FLOW,VICTOR ETUX  
PHYSICAL ADDRESS: 107 SUNSET LN  
BEAUFORT  
MAILING ADDRESS: 18 GRAYLYN PLACE CT  
WINSTON SALEM NC 27106  
LEGAL DESCRIPTION: PART L38 OLD TOWN BEAUFORT.  
DEED REF: 1801-386  
PLAT REFERENCE: -  
NEIGHBORHOOD: 590003

PARCEL NUMBER: 730617014104000  
OWNER: ASKEY,BARBARA LEE TRUSTEE  
PHYSICAL ADDRESS: 105 SUNSET LN  
BEAUFORT  
MAILING ADDRESS: 182 TRANKILO STREET  
APT 604  
TAMUNING,GUAM 96913  
LEGAL DESCRIPTION: PART L38 OLD TOWN BEAUFORT.  
DEED REF: 1759-359  
PLAT REFERENCE: -  
NEIGHBORHOOD: 590003

PARCEL NUMBER: 730617015033000  
OWNER: MOORE,MICHAEL A ETAL WILLIAM M  
PHYSICAL ADDRESS: 122 SUNSET LN  
BEAUFORT  
MAILING ADDRESS: 113 MOORE STREET  
BEAUFORT NC 28516  
LEGAL DESCRIPTION: PART L38 OLD TOWN BEAUFORT.  
DEED REF: 1773-075  
PLAT REFERENCE: -  
NEIGHBORHOOD: 590003



PARCEL NUMBER: 730617015110000  
 OWNER: JOHN & JOSEPH LLC  
 PHYSICAL ADDRESS: 124 SUNSET LN  
 BEAUFORT  
 MAILING ADDRESS: 325 FRONT STREET  
 BEAUFORT NC 28516  
 LEGAL DESCRIPTION: L2 J C DAVIS  
 DEED REF: 1373-341  
 PLAT REFERENCE: 30-373  
 NEIGHBORHOOD: 590001

PARCEL NUMBER: 730617016012000  
 OWNER: DUNCAN,JOHN N III ETAL  
 PHYSICAL ADDRESS: 115 MOORE ST  
 BEAUFORT  
 MAILING ADDRESS: 115 MOORE ST  
 BEAUFORT NC 28516  
 LEGAL DESCRIPTION: PART L38 OLD TOWN BEAUFORT MOORE STREET  
 DEED REF: 0785-00840  
 PLAT REFERENCE: -  
 NEIGHBORHOOD: 590003

PARCEL NUMBER: 730617006918000  
 OWNER: MOORE,MICHAEL A ETAL WILLIAM M  
 PHYSICAL ADDRESS: 113 MOORE ST  
 BEAUFORT  
 MAILING ADDRESS: 113 MOORE STREET  
 BEAUFORT NC 28516  
 LEGAL DESCRIPTION: PART L38 OLD TOWN BEAUFORT.  
 DEED REF: 1773-074  
 PLAT REFERENCE: -  
 NEIGHBORHOOD: 590003

PARCEL NUMBER: 730617005955000  
OWNER: BEACON STREET BRADLEY LLC  
PHYSICAL ADDRESS 0  
MAILING ADDRESS: 3126 SUSSEX RD  
RALEIGH NC 27607  
LEGAL DESCRIPTION: COMMON AREA BRADLEY HOUSE COND OS  
DEED REF: 1177-038  
PLAT REFERENCE: 10S-965  
NEIGHBORHOOD: 900151

PARCEL NUMBER: 730617005903000  
OWNER: ELLINGTON,JOHNS N ETUX ETAL  
PHYSICAL ADDRESS 103 4 MOORE ST  
BEAUFORT  
MAILING ADDRESS: 5721 WINTHROP DRIVE  
RALEIGH NC 27612  
LEGAL DESCRIPTION: UNIT 4 BRADLEY HOUSE CONDOS  
DEED REF: 1778-058  
PLAT REFERENCE: 10S-965  
NEIGHBORHOOD: 900151

PARCEL NUMBER: 730617004879000  
OWNER: GLASGOW,MOLLY H ETVIR THOMAS B  
PHYSICAL ADDRESS 103 2 MOORE ST  
BEAUFORT  
MAILING ADDRESS: 2806 O'BERRY STREET  
RALEIGH NC 27607  
LEGAL DESCRIPTION: UNIT 2 BRADLEY HOUSE CONDOS  
DEED REF: 1647-185  
PLAT REFERENCE: 10S-965  
NEIGHBORHOOD: 900151

PARCEL NUMBER: 730617004867000  
OWNER: DURSO,LEE ETAL K SHAVER  
PHYSICAL ADDRESS: 103 6 MOORE ST  
BEAUFORT  
MAILING ADDRESS: 652 WALTERS DRIVE  
WAKE FOREST NC 27587  
LEGAL DESCRIPTION: UNIT 6 BRADLEY HOUSE CONDOS  
DEED REF: 1741-374  
PLAT REFERENCE: 10S-965  
NEIGHBORHOOD: 900151

PARCEL NUMBER: 730617005931000  
OWNER: BRADLEY HOUSE UNIT 3 LLC  
PHYSICAL ADDRESS: 103 3 MOORE ST  
BEAUFORT  
MAILING ADDRESS: 103 MOORE STREET UNIT 3  
BEAUFORT NC 28516  
LEGAL DESCRIPTION: UNIT 3 BRADLEY HOUSE CONDOS  
DEED REF: 1741-028  
PLAT REFERENCE: 10S-965  
NEIGHBORHOOD: 900151

PARCEL NUMBER: 730617005940000  
OWNER: ODOM,KELLY ETVIR BRIAN ENGLISH  
PHYSICAL ADDRESS: 103 7 MOORE ST  
BEAUFORT  
MAILING ADDRESS: 2640 DAVIS STREET  
RALEIGH NC 2030 27608  
LEGAL DESCRIPTION: UNIT 7 BRADLEY HOUSE CONDOS  
DEED REF: 1655-114  
PLAT REFERENCE: 10S-965  
NEIGHBORHOOD: 900151

PARCEL NUMBER: 730617005826000  
OWNER: WELBORN,DARRELL ETUX PAT LYNN  
PHYSICAL ADDRESS 103 5 MOORE ST  
BEAUFORT  
MAILING ADDRESS: 3903 PAYNE ROAD  
HIGH POINT NC 27265  
LEGAL DESCRIPTION: UNIT 5 BRADLEY HOUSE CONDOS  
DEED REF: 1610-222  
PLAT REFERENCE: 10S-965  
NEIGHBORHOOD: 900151

PARCEL NUMBER: 730617005814000  
OWNER: CAPLAN,JASON ALAN  
PHYSICAL ADDRESS 103 1 MOORE ST  
BEAUFORT  
MAILING ADDRESS: 131 OLD PAMLICO BCH RD W  
BELHAVEN NC 9104 27810  
LEGAL DESCRIPTION: UNIT 1 BRADLEY HOUSE CONDOS  
DEED REF: 1726-024  
PLAT REFERENCE: 10S-965  
NEIGHBORHOOD: 900151

PARCEL NUMBER: 730617004850000  
OWNER: FLEET,CLIFFORD III ETUX FRAN  
PHYSICAL ADDRESS 0  
MAILING ADDRESS: 512 SOMERSET AVENUE  
RICHMOND VA 23226  
LEGAL DESCRIPTION: COMM AREA PH.1 DAVIS BOARDING HOUSE  
CONDOS  
DEED REF: 1495-471  
PLAT REFERENCE: 10T-188  
NEIGHBORHOOD: 900169

PARCEL NUMBER: 730617004743000  
OWNER: SMITH,GORDON III ETUX BEVERLY  
PHYSICAL ADDRESS 125 FRONT ST  
BEAUFORT  
MAILING ADDRESS: 3323 ALLEGHANY DRIVE  
RALEIGH NC 27609  
LEGAL DESCRIPTION: UNIT A PH. 1 DAVIS BOARDING HOUSE CONDOS  
DEED REF: 1472-143  
PLAT REFERENCE: 10T-183  
NEIGHBORHOOD: 900169

PARCEL NUMBER: 730617004713000  
OWNER: FLEET,CLIFFORD III ETUX FRAN  
PHYSICAL ADDRESS 123 FRONT ST  
BEAUFORT  
MAILING ADDRESS: 512 SOMERSET AVENUE  
RICHMOND VA 23226  
LEGAL DESCRIPTION: UNIT B PH. 1 DAVIS BOARDING HOUSE CONDOS  
DEED REF: 1495-471  
PLAT REFERENCE: 10T-188  
NEIGHBORHOOD: 900169

PARCEL NUMBER: 730617003786000  
OWNER: TOWNSEND,ELIZABETH M ETVIR  
PHYSICAL ADDRESS 121 FRONT ST  
BEAUFORT  
MAILING ADDRESS: 121 FRONT ST  
BEAUFORT NC 2143 28516  
LEGAL DESCRIPTION: UNIT C PH. 1 DAVIS BOARDING HOUSE CONDOS  
DEED REF: 1622-125  
PLAT REFERENCE: 10T-183  
NEIGHBORHOOD: 900169

PARCEL NUMBER: 730617004728000  
OWNER: LANTERI, ANNE T  
PHYSICAL ADDRESS: 119 FRONT ST  
BEAUFORT  
MAILING ADDRESS: 119 FRONT STREET  
BEAUFORT NC 2143 28516  
LEGAL DESCRIPTION: UNIT D PH. 1 DAVIS BOARDING HOUSE CONDOS  
DEED REF: 1488-447  
PLAT REFERENCE: 10T-188  
NEIGHBORHOOD: 900169

PARCEL NUMBER: 730617003895000  
OWNER: COPLAND, JASON C ETAL  
PHYSICAL ADDRESS: 117 FRONT ST  
BEAUFORT  
MAILING ADDRESS: 3156 ABINGDON PLACE  
BURLINGTON NC 27215  
LEGAL DESCRIPTION: COMMON AREA - MANSON HOUSE TR1 BEAUFORT  
DEED REF: 1489-060  
PLAT REFERENCE: 10I-084  
NEIGHBORHOOD: 900102

PARCEL NUMBER: 730617003870000  
OWNER: COPLAND, JASON C ETAL SPENCER  
PHYSICAL ADDRESS: 117 FRONT ST  
BEAUFORT  
MAILING ADDRESS: 3156 ABINGDON PLACE  
BURLINGTON NC 27215  
LEGAL DESCRIPTION: U4 MASON HOUSE CONDO  
DEED REF: 1489-60  
PLAT REFERENCE: 10I-84  
NEIGHBORHOOD: 900102

PARCEL NUMBER: 730617003850000  
OWNER: HOOPER,CHRISTOPHER TODD  
PHYSICAL ADDRESS 117 FRONT ST  
BEAUFORT  
MAILING ADDRESS: 109 WYNDHAM DR  
GARNER NC 27529  
LEGAL DESCRIPTION: U3 MASON HOUSE CONDO  
DEED REF: 1796-295  
PLAT REFERENCE: 10I-84  
NEIGHBORHOOD: 900102

PARCEL NUMBER: 730617003881000  
OWNER: MANSON HOUSE ASSETS LLC  
PHYSICAL ADDRESS 117 FRONT ST  
BEAUFORT  
MAILING ADDRESS: 553 CAROLINA MDWS VILLA  
CHAPEL HILL NC 27517  
LEGAL DESCRIPTION: U2 MASON HOUSE CONDO  
DEED REF: 978-232  
PLAT REFERENCE: 10I-84  
NEIGHBORHOOD: 900102

PARCEL NUMBER: 730617003862000  
OWNER: CRAMER,ADELE B  
PHYSICAL ADDRESS 117 FRONT ST  
BEAUFORT  
MAILING ADDRESS: 809 DEVON PLACE  
ALEXANDRIA VA 22314  
LEGAL DESCRIPTION: U1 MASON HOUSE CONDO  
DEED REF: 0104-00093  
PLAT REFERENCE: -  
NEIGHBORHOOD: 900102

PARCEL NUMBER: 730617003801000  
OWNER: CANDLEWOOD INVESTMENTS LLC  
PHYSICAL ADDRESS 115 FRONT ST  
BEAUFORT  
MAILING ADDRESS: PO BOX K  
ROCKY MOUNT NC 27804  
LEGAL DESCRIPTION: TR A & B SALLY E FULFORD  
DEED REF: 1589-187  
PLAT REFERENCE: 31-620  
NEIGHBORHOOD: 590005

PARCEL NUMBER: 730617005826000  
OWNER: WELBORN,DARRELL ETUX PAT LYNN  
PHYSICAL ADDRESS 103 5 MOORE ST  
BEAUFORT  
MAILING ADDRESS: 3903 PAYNE ROAD  
HIGH POINT NC 27265  
LEGAL DESCRIPTION: UNIT 5 BRADLEY HOUSE CONDOS  
DEED REF: 1610-222  
PLAT REFERENCE: 10S-965  
NEIGHBORHOOD: 900151



Photos:

FRONT ELEVATION



REAR ELEVATION



SOUTH SIDE ELEVATION



NORTH SIDE ELEVATION



## Proposed Materials

1. Wood picket fence painted white.
2. Bradley (Post/Column Lantern)
3. Dublin Cobble Modular Pavers

- About
- Lighting »
- Custom/Restoration
- Installations
- Specifications »
- Catalog
- Contact Us
- Showrooms

- Lighting
- Post/Column Mount
- Bradley (Post/Column)



## Bradley (Post/Column)

---

Size (Including Mounting):  
(Click here for specification pages)  
H32" W15" D15"

- 
- Configurations Available:
- Post Mount (Shown)
  - Column Mount
  - C Bracket
  - J Bracket
  - Scroll Bracket
  - Hanging

- 
- Finishes:
- Natural Copper
  - Dark Copper
  - Museum Copper
  - Verdigris Copper (Shown)
  - Natural Brass
  - Antique Brass
- (See Finish Swatches)*
-

Dublin Cobble Modular Pavers







Landscape Architect Seal

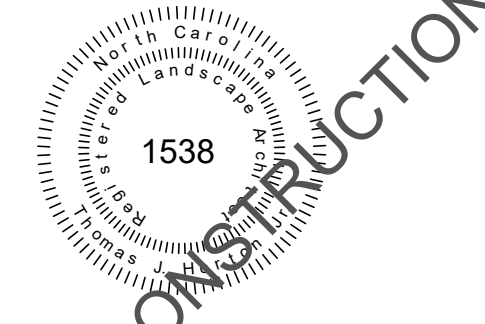

Firm Seal

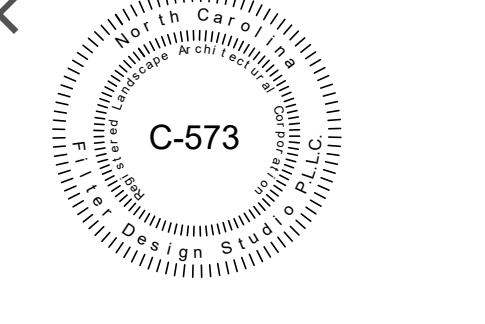

**Architecture**

Company: Filter Design Studio, P.L.L.C.  
Architect: Ryan Edwards  
Address: 707 BRIDGES STREET  
Morehead City, NC 28557  
Phone: 252-622-4119  
Email: ryan@filterdesignstudio.com

**Landscape Architecture**

Company: Filter Design Studio, P.L.L.C.  
Landscape Architect: Jay Horton  
Address: 707 BRIDGES STREET  
Morehead City, NC 28557  
Phone: 252-622-4119  
Email: jay@filterdesignstudio.com

SUNSET LANE PROPERTIES

HPC

SUNSET LANE,  
BEAUFORT, NC

All drawing and designs are protected by commonlaw copyright and exclusively belong to Filter Design Studio, P.L.L.C. All use, printing, construction and modifications require express permission

No.	Description	Date

**Planting Plan**

Project number: 2023-30  
Date: 2023-09-01  
Drawn by: JH  
Review: JH

**LA102**

Scale: 1"=10'

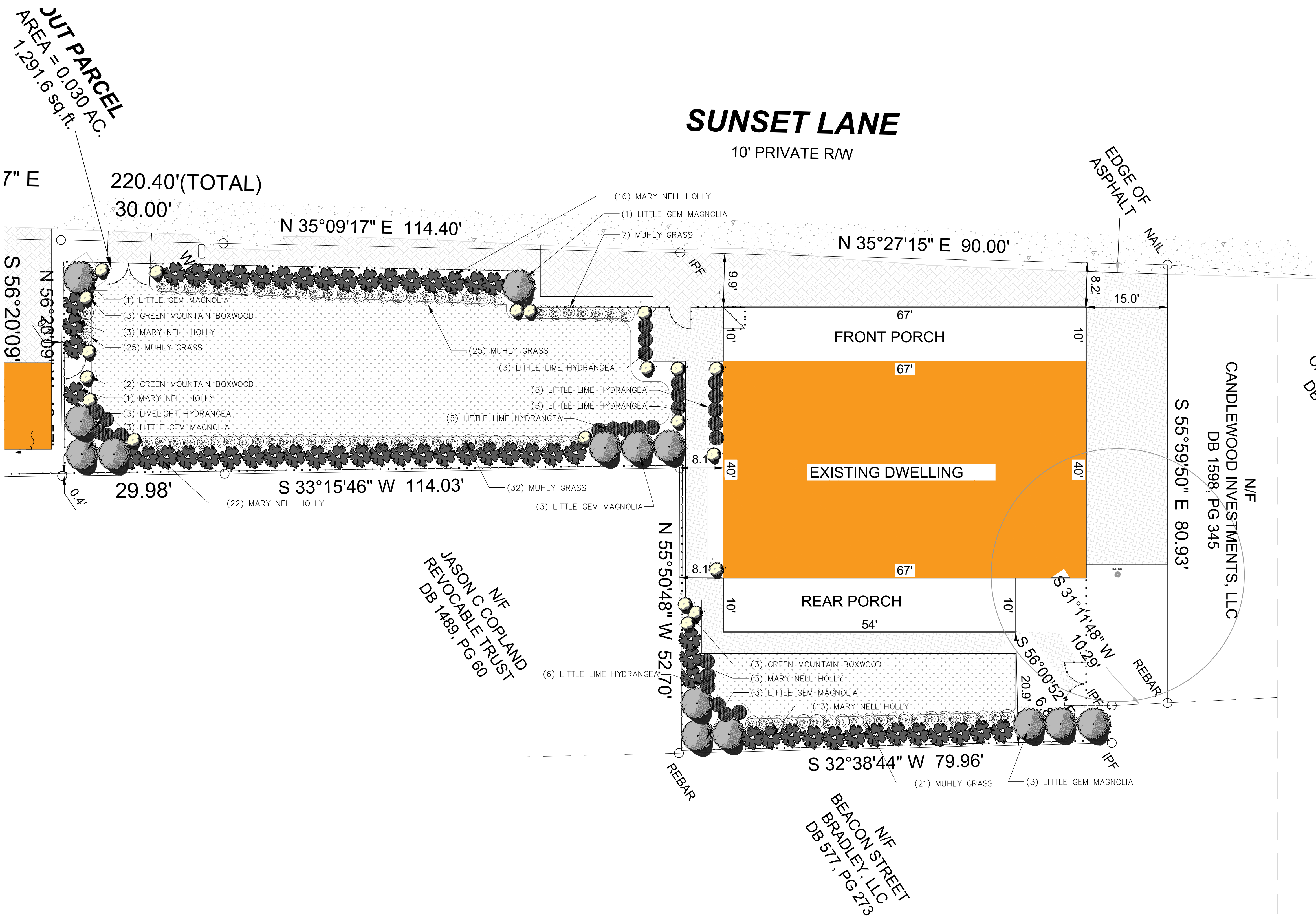

**TURF NOTES**

- Till natural and planting areas and spread topsoil 3 inches deep over adverse soil conditions, if available.
  - Rip entire area.
  - Remove all loose rock, roots, and other obstructions leaving surface reasonably smooth and uniform.
  - Apply agricultural lime, fertilizer, and superphosphate uniformly as recommended by soils test.
  - Continue tillage until a well-pulverized, firm, reasonably uniform seedbed is prepared 4 to 6 inches deep.
- Sod Preparation:**  
Follow preparation as directed for steps 1-5 above. Immediately water sod upon installation and continue until roots are established.
- Contractor shall water and maintain all lawn areas for 6 weeks or an acceptable stand of grass has been established and signed off on by landscape architect or owners representative.
  - Once an acceptable stand of grass has been established, the Contractor shall repair all damaged areas and monitor the lawn areas until the grass reaches an acceptable stand.
  - At the time the grass reaches a height, the Contractor shall mow the grass to the height recommended by North Carolina Turfgrass Association and turn over the lawn maintenance to the Owner.
  - An acceptable stand of grass shall be 92% coverage or better.

**IRRIGATION NOTES**

- Contractor shall provide irrigation for all new plantings AS SHOWN.
- Location of controller shall be approved by Owner prior to installation.
- Contractor shall coordinate meter, backflow preventer, permits, and electrical source with Owner prior to providing a cost estimate. These items are the Contractor's responsibility unless otherwise noted.
- See Irrigation Plan this set.

**PLANTING NOTES**

- Prior to the start of any excavation for the project, the contractor shall notify NC One Call or equivalent to locate all existing utilities.
- Contractor shall maintain or provide positive drainage away from all building foundations, structures and within planting beds.
- Contractor shall supply all plant materials in quantities sufficient to complete all plantings shown on this drawing. Clarify any discrepancies with the Landscape Architect prior to ordering plant material.
- All plants shall meet or exceed the minimum standards set by the U.S.D.A. for Nursery Stock, sponsored by the American Association of Nurserymen, Inc., Washington, D.C.
- All plants shall bear the same relationship to finished grade as to the original grades before digging. The Contractor shall revise grades at a minimum of +/- 1/2% to ensure smooth transitions between planting beds and lawn areas.
- 3 inches Mulch - install stone mulch.
- All plant materials are subject to the approval of the Landscape Architect at the nursery and at the job site. Landscape Architect has the right to refuse any and all plant material on the site if deemed unacceptable due to size, health, etc..
- Contractor is encouraged to provide the Landscape Architect with concerns and/or suggestions regarding proposed plant materials, prior to placing a purchase order.
- Contractor is responsible for verifying all quantities. DRAWINGS SHALL RULE OVER PLANT SCHEDULE. Plant schedule is provided as a convenience to the contractor.
- All trees located adjacent to walks and drives shall have 6' of clearance height to first branching.
- All trees shall be placed a minimum of 3' from sidewalks, curbs, or fire hydrants.
- All plants shall be installed as per generally accepted planting details.
- All plants and stakes shall be set plumb unless otherwise specified.
- Refer to existing conditions plan for trees/shrubs to be either removed or to remain undisturbed if applicable.
- Landscape Architect shall select and layout all the perennial beds.
- All planting bed edges to be smooth flowing arcs unless otherwise noted.
- Bed edge shall be smooth, consistent, hand trenched 3 to 4 inches deep, and "V" shaped. All excavated material shall be removed from the bed edge and planting bed. If bed edging is proposed, contractor to use 1/4" thick steel edging.
- If the landscape contractor observes any deficiencies in the site conditions or which could negatively affect plant establishment, survival, or guarantee, notify the Owner and Landscape Architect prior to procurement and/or installation.
- Any disturbed areas that are not planted or grassed as part of the landscape plan shall be restored to their previous existing condition (including raking uneven areas, seeding grassed areas and for natural areas spreading minimum 2' depth of mulch).
- Site information has been provided by OTHERS. Jay Horton Designs is not responsible for any discrepancies between actual site, plan and proposed plans.

QUAN.	PLANT SCHEDULE		SIZE	NOTES
	BOTANICAL NAME	COMMON NAME		
<b>TREES</b>				
58	ILEX X MARY NELL	MARY NELL HOLLY	8"	CONTAINER FULL
14	LAGERSTOEMIA INDICA NATCHEZ	LITTLE GEM MAGNOLIA	10'-12"	B/B FULL
<b>SHRUBS</b>				
88	MULLENBERGIA CAPILLARIS	PINK MUHLY GRASS	7 GAL	CONTAINER FULL
27	HYDRANGEA PANNICULATA	LITTLE LIME HYDRANGEA	7GAL	CONTAINER FULL
20	BUXUS SP.	GREEN MOUNTAIN BOXWOOD	30"-36"	CONTAINER FULL

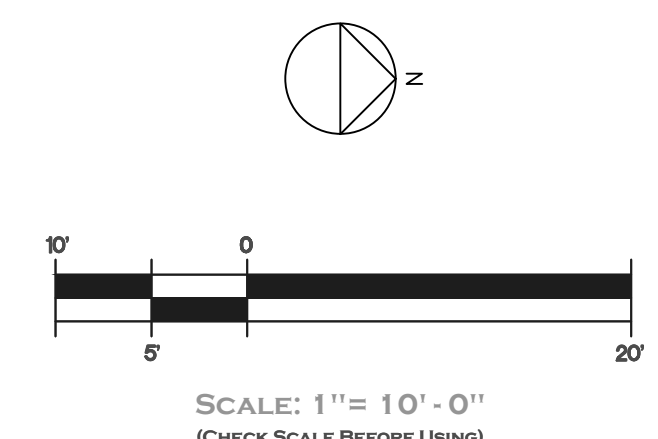
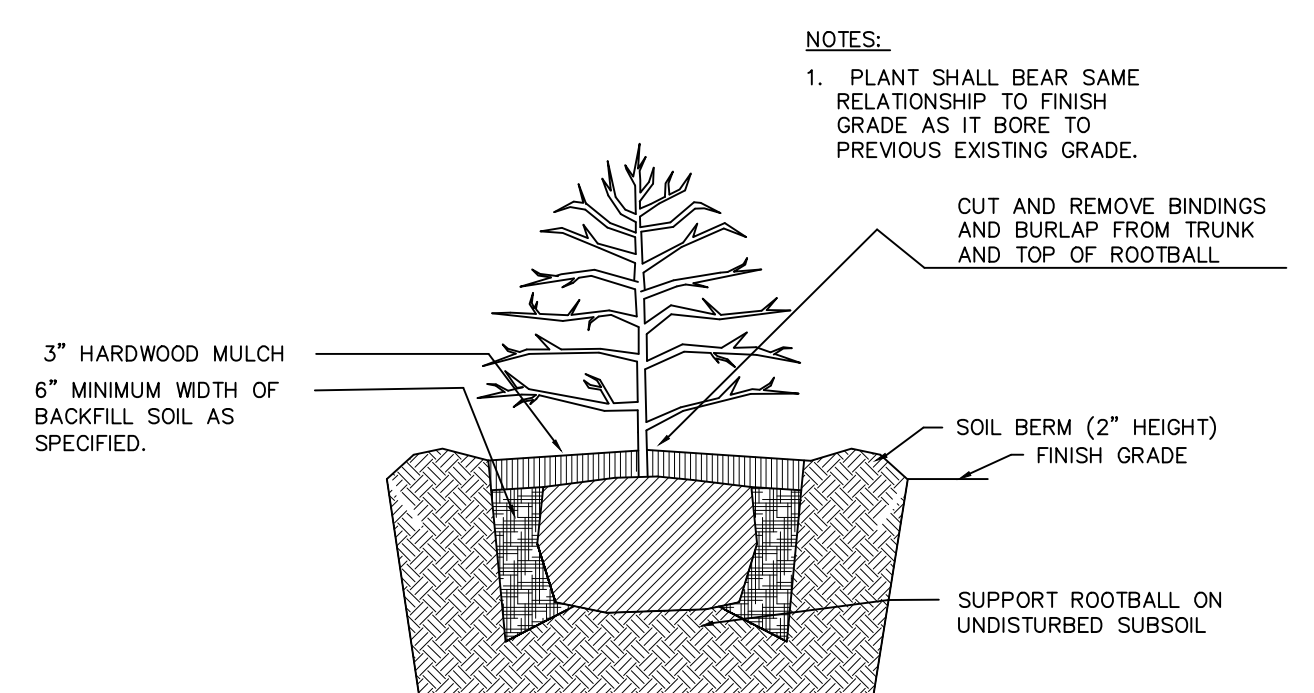
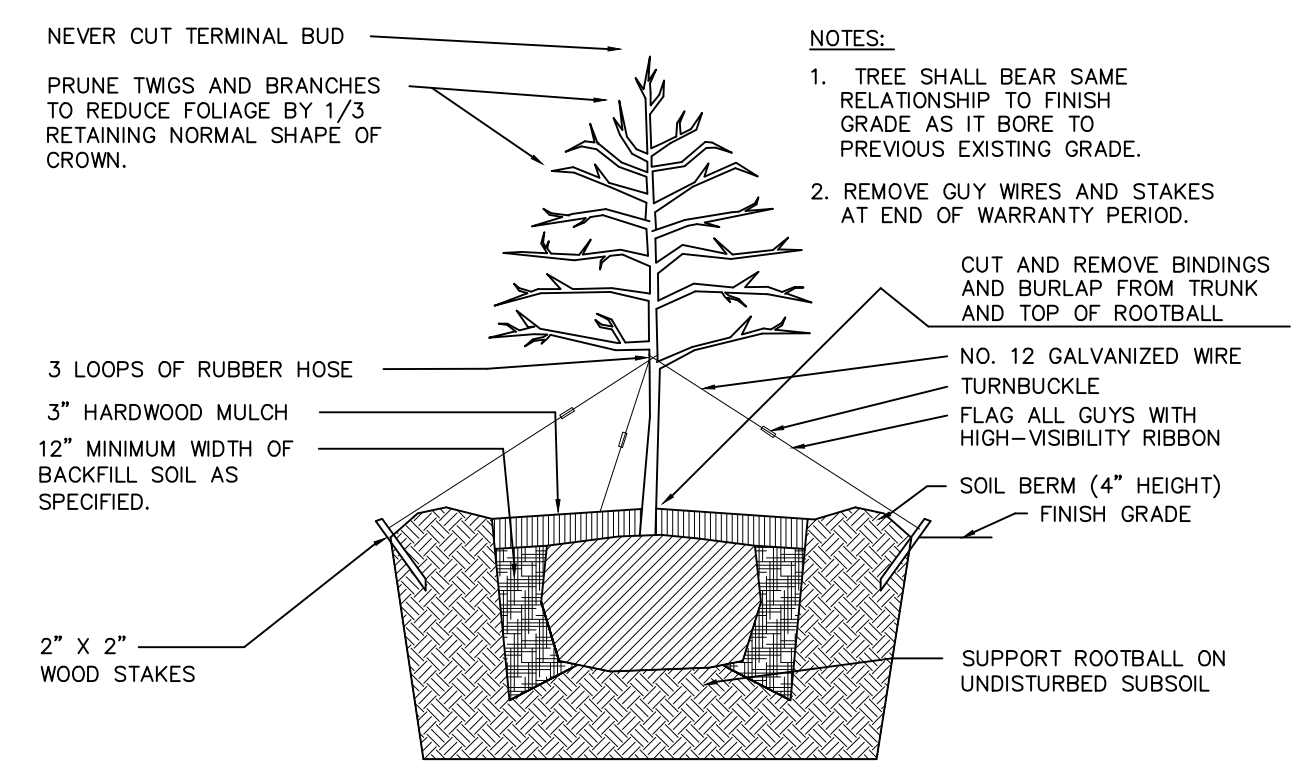

Landscape Architect Seal



Firm Seal

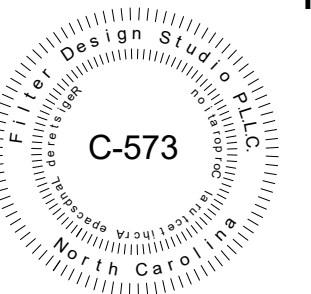

**Architecture**

Company: Filter Design Studio, P.L.L.C.  
 Architect: Ryan Edwards  
 Address: 707 Bridges Street  
 Morehead City, NC 28557  
 Phone: 252-622-4119  
 Email: ryan@filterdesignstudio.com

**Landscape Architecture**

Company: Filter Design Studio, P.L.L.C.  
 Landscape Architect: Thomas "Jay" Horton  
 Address: 707 Bridges Street  
 Morehead City, NC 28557  
 Phone: 252-622-4119  
 Email: jay@filterdesignstudio.com

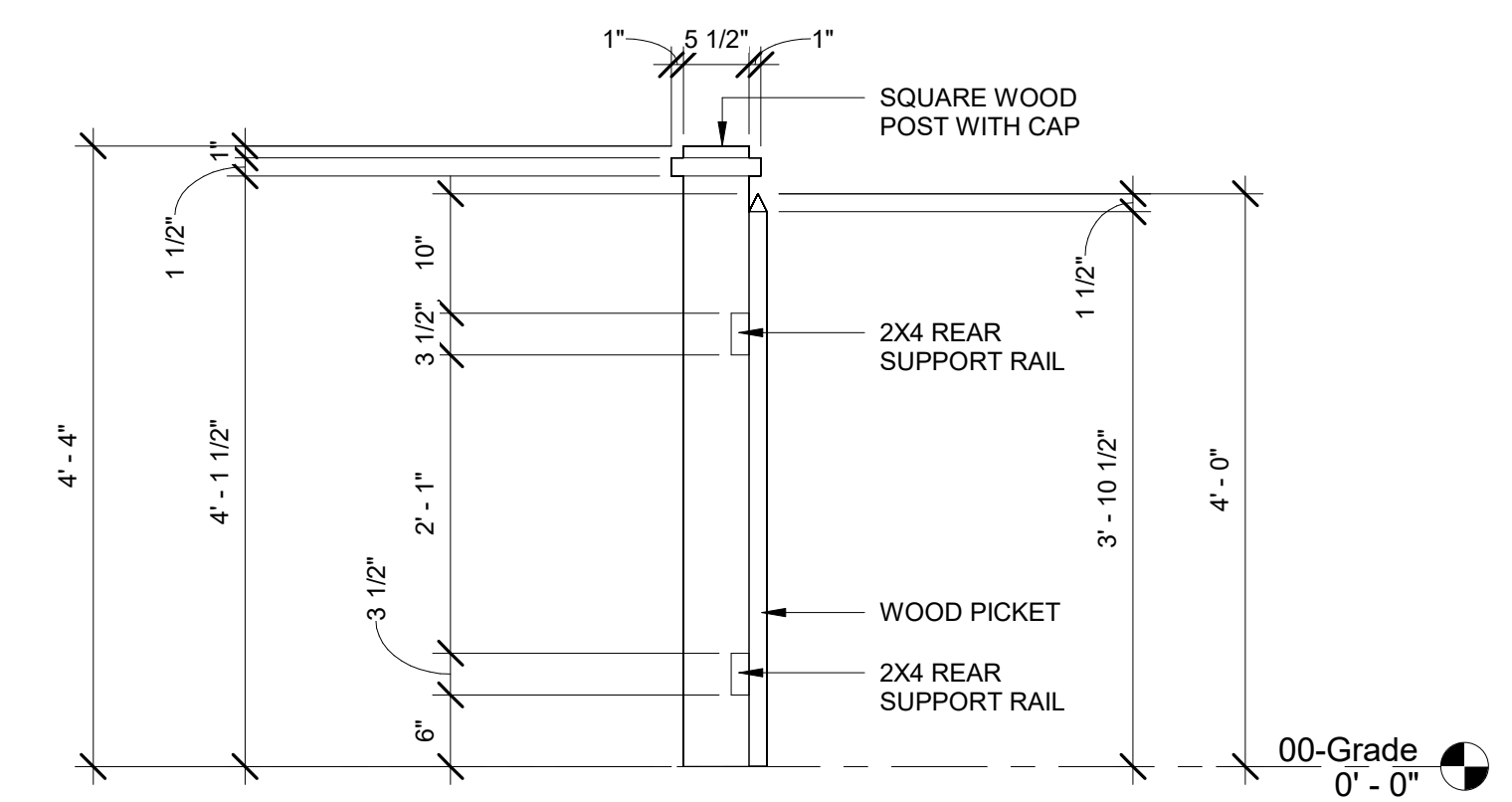

**3 Side Profile**  
3/4" = 1'-0"

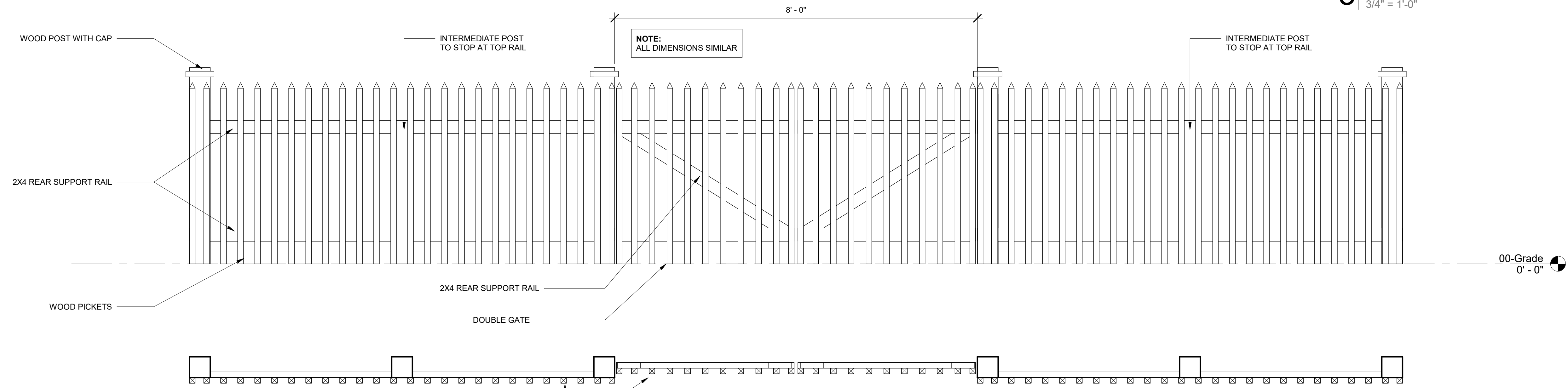

**2 8' Gate Layout**  
3/4" = 1'-0"

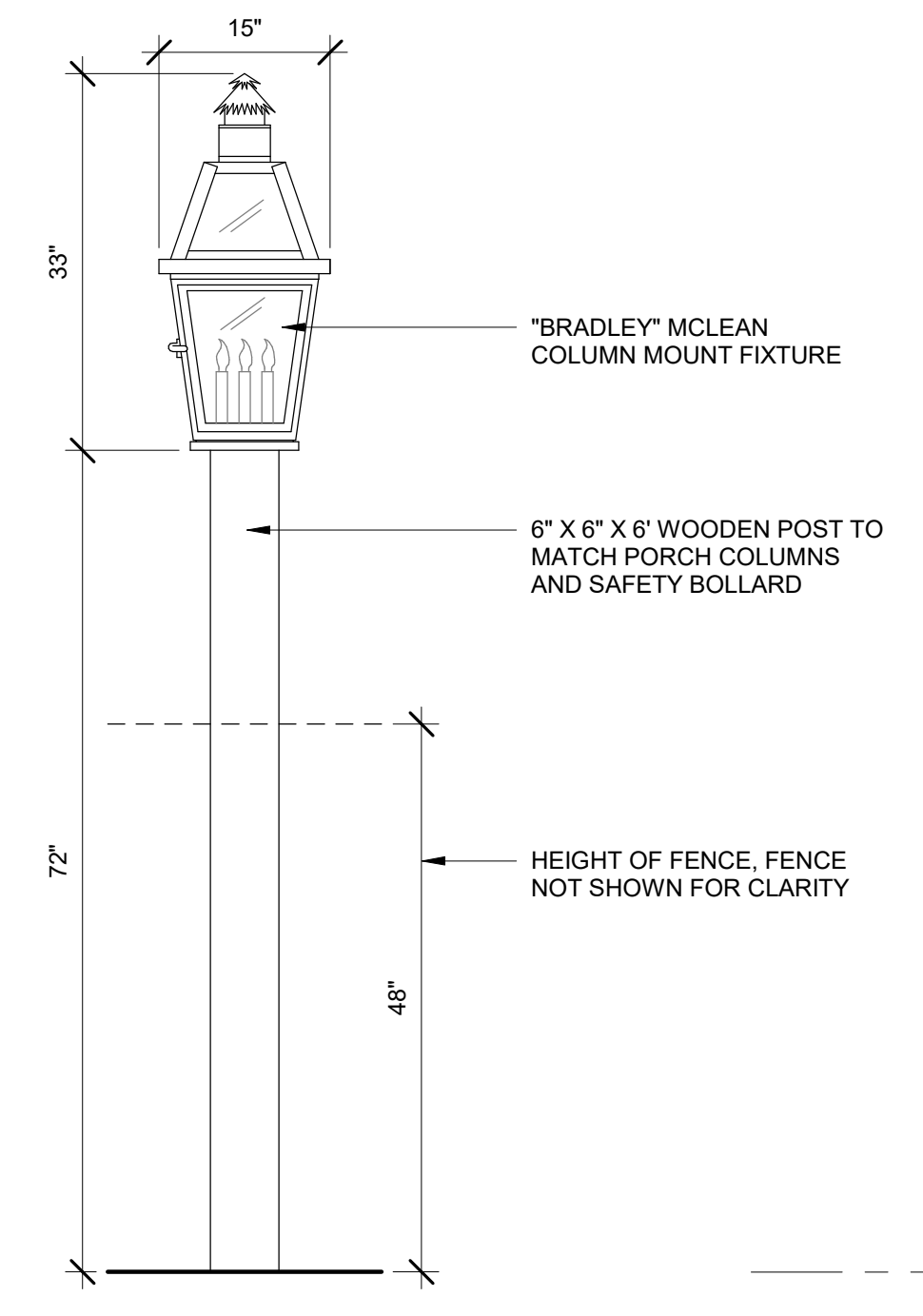

**4 Lamp Post Detail**  
3/4" = 1'-0"

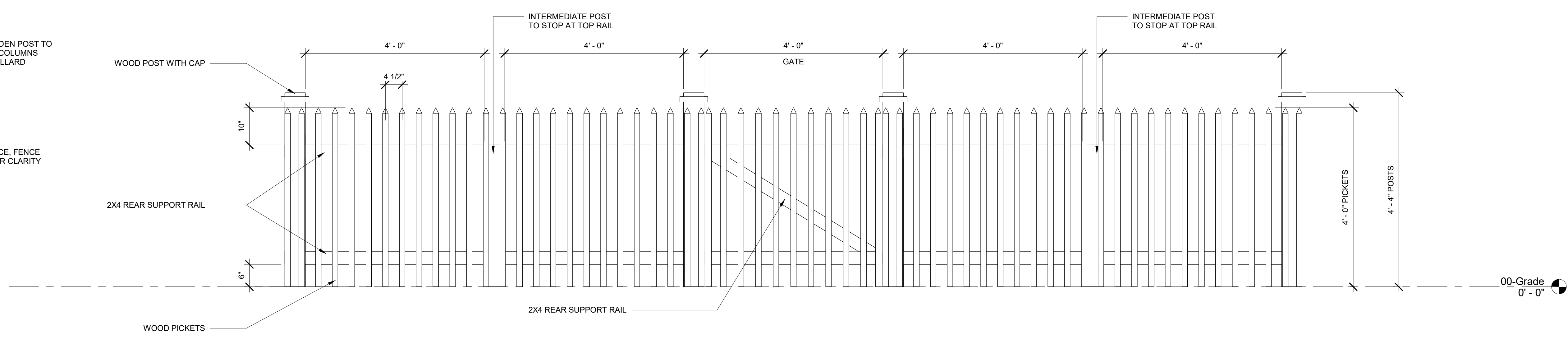

**1 4' Gate Layout**  
3/4" = 1'-0"

**Proposed Site Fencing**

**100 Sunset Lane**  
**Beaufort, North Carolina**

All drawing and designs are protected by commonlaw copyright and exclusively belong to Filter Design Studio, P.L.L.C. All use, printing, construction and modifications require express permission

No.	Description	Date

Fence Details	
Project number	23-030
Date	2023-10-17
<b>LA501</b>	
Scale	3/4" = 1'-0"



**Town of Beaufort, NC**

701 Front St. - P.O. Box 390 - Beaufort, N.C. 28516  
252-728-2141 - 252-728-3982 fax - www.beaufortnc.org

**Town of Beaufort Historic Preservation Commission Regular Meeting  
6:00 PM Tuesday, November 7, 2023 – 614 Broad Street – Train Depot**

---

**AGENDA CATEGORY:** New Business

**SUBJECT:** Case # 23-35 121 Craven Street - Brick Walkway

**BRIEF SUMMARY:**

The owner wishes to demo the existing concrete walk and replace it with a new walkway with brick pavers.

**REQUESTED ACTION:**

Conduct Quasi- Judicial Hearing

**EXPECTED LENGTH OF PRESENTATION:**

10 Minutes

**SUBMITTED BY:**

Kyle Garner

**BUDGET AMENDMENT REQUIRED:**

N/A



# BHPC STAFF REPORT



**To:** BHPC Members  
**From:** Kyle Garner, AICP  
**Date:** October 31, 2023  
**Case No.** 23-35

**Request:** To remove existing concrete walk and replace them with brick pavers.

**Applicant:** Heather & Jerome Sink  
 310 Hedrick Street  
 Beaufort, NC 28516

**Property Information:**

**Owners:** Same  
**Location:** 121 Craven Street  
**PIN#:** 730617107115000, 730617107128000

**Project Information:** According to The Beaufort National Register Historic District Comprehensive Survey by M. Ruth Little, Ph.D. of 1997: 121 Craven Street, circa 1920. **House.** 2-Story, Neo-Classical, Foursquare house with hipped roof, 1/1 sash, and vinyl siding. Wrap-around porch has paired yellow brick piers with Doric columns and turned railing. Built between 1913 and 1924; mapped as the Undertaker's residence on the 1950 Sanborn map. (SM)

**Proposed work:**

Remove existing concrete walk and replace them with brick pavers.

**Material:**

Savannah Brick (Sample to be provided at meeting)

**Color:**

### Landscaping Guidelines

8.1.11. Historic sidewalks and other paving materials should be preserved and maintained. New sidewalks shall be compatible in material, detailing, color, and finish to existing historic sidewalks.

# Case # 23-35 121 Craven Street - Brick Walkway

**Legend**

- NCHPOpoints
- Tax\_Parcel\_Data



<u>OWNER</u>	<u>MAIL_HO1</u>	<u>MAIL_ST</u>	<u>MAIL_CITY</u>	<u>MAIL_Z1</u>	<u>MAIL_Z2</u>	<u>MAIL_ADD2</u>
BEAUFORT LINEN INTERIORS LLC	125	CRAVEN STREET	BEAUFORT	NC	28516	
CUMMINS,BRADLEY ETUX PRESCOTT	1314	ANN STREET UNIT A	BEAUFORT	NC	28516	
GREENBERG,BRENT ETUX SINDEE			BEAUFORT	NC	28516	PO BOX 27
IRA SERVICES TRUST COMPANY	104	TAYLORS CREEK LN	BEAUFORT	NC	28516	
OLD TOWN BEAUFORT LLC	131	MIDDLE LANE	BEAUFORT	NC	28516	
SANTORO,DINA CHARLENE TRUSTEE	2603	ONE IRON ST	MOREHEAD CITY	NC 4961	28557	
SINK,HEATHER ET VIR JEROME	310	HEDRICK STREET	BEAUFORT	NC	28516	

**CERTIFICATE OF APPROPRIATENESS APPLICATION  
FOR PROJECTS WITHIN THE BEAUFORT HISTORIC DISTRICT**



**Instructions:**

Please complete the application below and include all attachments as noted on page 2 of this application along with a **\$250.00 application fee** and return to the Beaufort Town Hall; 701 Front Street or P.O. Box 390, Beaufort, N.C. 28516. Incomplete applications will not be processed and **will be** returned to the applicant. Applications must be deemed complete and accepted before the submittal date. Please contact Town Hall at 252-728-2142 if there are any questions.

**APPLICANT/OWNER INFORMATION**

Please print!

Applicant Name: HEATHER AND JEROME SINK

Applicant Address: 310 HEDRICK ST, BEAUFORT

Business Phone: 919-630-5332 Email/Cell: jettysink@ec.cc.com

Property Owner Name: HEATHER AND JEROME SINK

Address of Property: 121 CRAVEN ST, BEAUFORT

Phone Number: SAME AS ABOVE Email/Cell: SAME AS ABOVE

**PROJECT INFORMATION**

Detailed description of the Proposed Project (please attach additional pages if necessary):

REMOVE CRACKED AND BROKEN BRICK AND CONCRETE FROM THE STEPS AND WALK AT THE FRONT PORCH. REPLACE WITH SAVANNAH BRICK/PAVERS.

CURRENT STEPS AND WALK ARE TRIPPING HAZZARDS.

Estimated Cost of Project: \$28,000.00

Year House Built: 1918

Heather Sink  
Applicant Signature

Oct 16, 2023  
Date

[Signature]  
Property Owner Signature (if different than above)

Oct 16, 2023  
Date

An application fee of \$250.00, either in cash, money order, or check made payable to the "Town of Beaufort" must accompany this application (a credit or debit card payment can be made in person at Town Hall). The complete application, payment, and supporting material must be received by Town Staff by the posted submittal dates noted on the Historic Preservation's calendar found on the Town's website at [www.beaufortnc.org](http://www.beaufortnc.org). The Commission meets regularly on the first Tuesday of the month unless it is a holiday.

**OFFICE USE ONLY**

Received by: \_\_\_\_\_

Reviewed for Completeness: \_\_\_\_\_

Date: \_\_\_\_\_

Deemed Completed and Accepted: \_\_\_\_\_



**REQUIRED ATTACHMENTS FOR A CERTIFICATE OF APPROPRIATENESS (COA)**

*Please provide the following along with this checklist form, with the COA application:*

**1. Items required for ALL projects:**

- A list of all Design Guidelines that apply to the application and a description of how proposed changes are consistent with the *Design Guidelines for the Beaufort Historic District & Landmarks*, which can be found at <https://www.beaufortnc.org/bc-hpc/page/design-guidelines-beaufort-historic-district-landmarks>
- A list of all adjacent property owners (with mailing addresses).
- Photographs of the streetscape, the site, and existing buildings to be impacted.
- A site plan showing dimensions of both existing and proposed conditions.
- A description of all building and/or landscaping materials (such as siding, roofing, windows, doors, signs, planting materials, etc.).

**2. Items required as applicable to project:**

- A description of any planned demolition. *REMOVAL OF*
- An indication of all trees to be replaced and/or removed. *XNONE*
- ~~N/A~~ A landscaping plan indicating major planting materials.
- ~~N/A~~ Exterior paint color sample/color swatch(s) for projects involving any change of exterior paint color(s) only.
- All types of building material samples.
- ~~N/A~~ If a project involves the reconstruction of an earlier feature of a historic structure, documentation of the prior existence of such feature.

**3. Additional items required (only) for new Signage:**

- ~~N/A~~ A drawing or true likeness of the new sign indicating the dimensions of the sign (and any supporting post or hanging apparatus if applicable). The lettering style and colors of the sign should also be on the drawing or likeness.
- ~~N/A~~ A paint sample/color swatch of all color(s) to be used both on the sign and on the post or hanging apparatus if applicable.

**4. At least one set of materials, in color**, that are to be evaluated by the Commission should be submitted with the application. An electronic or digital file of the work should also be submitted. Please contact Town Staff to see what electronic or digital file can be submitted.

**5. The applicant or a representative for the applicant must be present at the meeting** for action to be taken on the application. If it is not possible for the applicant or their representative to be present at the assigned meeting, please contact Town Staff as soon as possible.

*A COA is valid for a period of six (6) months and may be renewed for an additional six months via written request to Town Staff from the applicant (please state all reasons why the extension is needed). If work has not begun or a [building permit](#) for the project has not been obtained within the six-month period, the COA is deemed invalid. The COA is considered issued once the Commission approves the application at their meeting.*

*If there are questions regarding what should or should not be included with this application, please contact Town Staff at 252-728-2142 or at [k.garner@beaufortnc.org](mailto:k.garner@beaufortnc.org).*

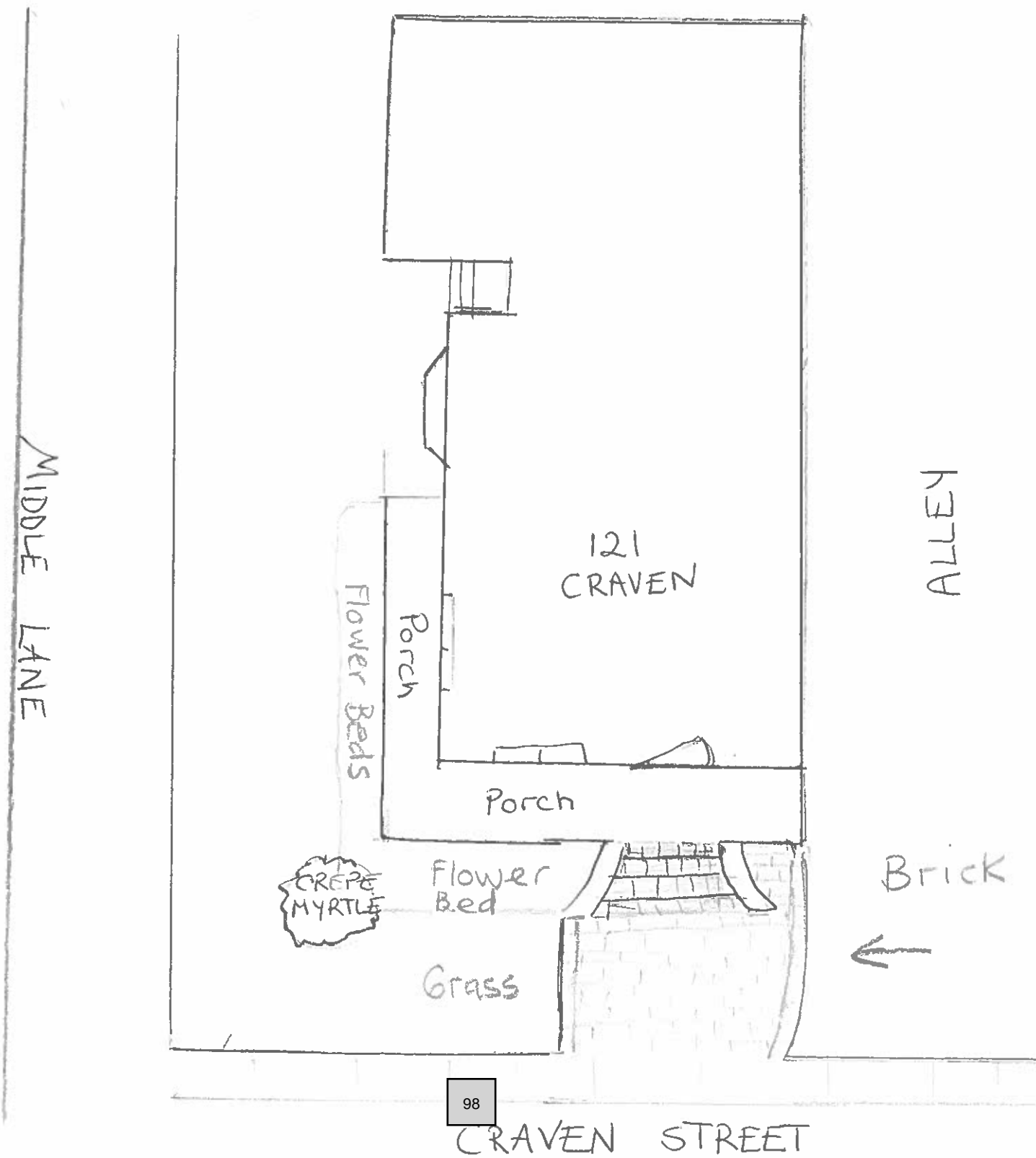

## Demolition of Buildings Guidelines

10.1.1. Choose demolition only as a last resort. Property owners of contributing buildings should design the replacement building to reflect the demolished building’s height, scale, massing and location. Applicants will have a heavy burden to demonstrate to the HPC that a replacement building with different height, scale, massing as the previously existing building is congruous with the Historic District.

The deterioration of the concrete and bricks used on the steps and walk are so severe as needing replacement.

10.1.2. Document the historic resource prior to demolition. Documentation shall take the form of black and white photographs, and color digital photographs of the building, structure, or site’s principal elevations, architectural elements (both in exterior and interior), and special features. Measured drawings of the resource may also be required. The HPC shall determine on a case-by-case basis the extent of documentation required and the parties responsible for producing such documentation. The documentation shall be submitted to the HPC and become a permanent record of the Town of Beaufort.

There are no historic elements to document or salvage; any that may have existed are unknown.

10.1.3. Salvage architectural features and building materials for reuse or study. Contact antique dealers and used building supply establishments to arrange for removal. Consider donations of items to interested non-profit organizations or museums or the NC-SHPO.

There are no historic elements to document or salvage; any that may have existed are unknown.

10.1.4. Minimize ground-disturbing activities during demolition to avoid damage to potential unknown archaeological resources.

Ground-disturbing activities will be minimalized to avoid damage to unknown archeological resources. Foundation and step arms will be preserved.

10.1.5. Retain mature trees on site.

There are no mature trees in the area of the renovation.

10.1.6. Clean the site thoroughly of all building debris and leave the lot properly graded and seeded.

The site will be thoroughly cleaned of all building debris and the lot graded and seeded where necessary.

### Landscaping Guidelines

8.1.1. Preserve and maintain historic public and private landscapes that contribute to the character of the historic district, including open spaces, streetscapes, and yards.

There is no landscaping that will be necessary to preserve.

8.1.10. Contemporary edging or border materials, such as exposed landscape timbers, railroad ties, pre-cast concrete, plastic, or other substitute material borders are not appropriate in areas seen from the public view.

The border for the walk will consist of the same pavers as the walk.

8.1.11. Historic sidewalks and other paving materials should be preserved and maintained. New sidewalks shall be compatible in material, detailing, color and finish to existing historic sidewalks.

Savannah brick will be used for the steps and savannah pavers will be used for the walk.



**Current Steps and Walk at 121 Craven Street**



**Steps were created with cement over brick**



**Detail of brick construction showing the cracking in the step**



**Walkway is becoming a tripping hazard and water pools at the lower step due to subsidence of the walk**



**Detail of more cracking at the front of the walk**



**The concrete molding is also deteriorating**





**This is the steps and walkway at 120 Craven**



**Steps and walk at 129 Craven (brick used for steps and walk)**



**Walk at 125 Craven (the same pavers and pattern will be used at 121)**



**Path and drive at 131 Craven**



**Some steps have portions missing from wear and tear**



**More detail of step deterioration**

Property Address	Owner	Mail Address	Mail City	Mail State	Mail Zip
117 Craven Street	Town of Beaufort	P.O. Box 390	Beaufort	NC	28516
120 Craven Street	Dina Charlene Santoro Trustee	2603 One Iron St	Morhead City	NC	28516
122 Craven Street	Brent Greenberg EXUX Sinee	P.O. Box 27	Beaufort	NC	28516
125 Craven Street	Mary Christina Baker	125 Craven St	Beaufort	NC	28516
127 Middle Lane	Bradley Cummins ETUX Prescottt	1314 Ann St, Unit A	Beaufort	NC	28516
133 Middle Lane	Old Town Beaufort LLC	131 Middle Lane	Beaufort	NC	28516



**TRIANGLE  
BRICK**

MAKING  
QUALITY  
AFFORDABLE

4.

**Date:** 10/9/23

**To:** Michelle Van Barneveld

**Attention:** Michelle

**Email:** [Michelle.Barneveld@oldcastle.com](mailto:Michelle.Barneveld@oldcastle.com)

**Job:** 131 Middle Lane Beaufort

**Brick:** #1103 Savannah Modular

**General Contractor:** Owens Construction

Dear Michelle:

This letter is to certify that Triangle's #1103 Savannah Modular brick meets or exceeds the requirements of Type FBS, Grade S.W. for the ASTM specification C-216.

If I can be of further assistance, please do not hesitate to give me a call.

Sincerely,

Ken Holland  
Director of Sales, NC Region



**Town of Beaufort, NC**

701 Front St. - P.O. Box 390 - Beaufort, N.C. 28516  
252-728-2141 - 252-728-3982 fax - www.beaufortnc.org

**Town of Beaufort Historic preservation Commission Regular Meeting  
6:00 PM Tuesday, November 7, 2023 – Train Depot**

---

**AGENDA CATEGORY:** New Business  
**SUBJECT:** 2024 Historic Commission Meeting and Submittal Calendar

**BRIEF SUMMARY:**

Our new administrative support specialist, Laurel Anderson, has developed the 2024 meeting and submittal calendar for the coming year. We ask that each member review the proposed dates and inform us of any conflicts at the November meeting.

**REQUESTED ACTION:**

Discussion on Proposed Calendar  
Decision on Proposed Calendar

**EXPECTED LENGTH OF PRESENTATION:**

5 Minutes

**SUBMITTED BY:**

Kyle Garner, AICP  
Planning & Inspections Director

**BUDGET AMENDMENT REQUIRED:**

N/A

**\*Proposed\***  
**BHPC Meeting Dates for 2024**  
**(First Tuesday of the Month)**

<b>Submission Deadline</b>	<b>Meeting Date</b>
12/12/2023	1/2/2024
1/16/2024	2/6/2024
2/13/2024	3/5/2024
3/12/2024	4/2/2024
4/16/2024	5/7/2024
5/14/2024	6/4/2024
6/11/2024	7/2/2024
7/16/2024	8/6/2024
8/13/2024	9/3/2024
9/10/2024	10/1/2024
10/15/2024	11/5/2024
11/12/2024	12/3/2024
12/17/2024	1/7/2025