



Town of Beaufort, NC

701 Front St. - P.O. Box 390 - Beaufort, N.C. 28516
252-728-2141 - 252-728-3982 fax - www.beaufortnc.org

Town of Beaufort Historic Preservation Regular Meeting 6:00 PM Tuesday, December 06, 2022 - Train Depot, 614 Broad Street, Beaufort, NC 28516 Monthly Meeting

Call to Order

Roll Call

Agenda Approval

Minutes Approval

- [1.](#) HPC Draft Minutes 11.1.22

Administration of Oaths

Items of Consent

- [1.](#) Approval of the Orders for 214 Broad Street & 214 Orange Street – Certificates of Appropriateness

New Business

- [1.](#) Case # 22-30 400 Front Street - Signage
- [2.](#) Case # 22-31 214 Orange Street – Accessory Structure
- [3.](#) Case # 22-33 118 Orange Street – Accessory Structure

Commission / Board Comments

Staff Comments

Adjourn



Town of Beaufort, NC
701 Front St. - P.O. Box 390 - Beaufort, N.C. 28516
252-728-2141 - 252-728-3982 fax - www.beaufortnc.org

Town of Beaufort Historic Preservation Regular Meeting
6:00 PM Tuesday, November 1, 2022 - Train Depot, 614 Broad Street, Beaufort, NC 28516
Minutes

Call to Order

Vice-Chair Flowers called the November 1, 2022 Beaufort Historic Preservation Commission regular meeting to order at 6:00 pm.

Roll Call

Members Present: Vice-Chair John Flowers, Bradley Cummins, Bradley Hedrick, Tammy Hunsucker, and John Stephens

Members Absent: Chair Joyce McCune, Bradley Cummins

A quorum was declared with five members present.

Staff Present: Kyle Garner, Town Attorney Jill Quattlebaum, and Laurel Anderson

Agenda Approval

Member Cummins made the motion to approve the Agenda and Member Stephens made the second. Vice-Chair Flowers took a vote that was unanimous.

Voting yea: Vice-Chair John Flowers, Bradley Cummins, Bradley Hedrick, Tammy Hunsucker, and John Stephens

Minutes Approval

1. HPC Draft Minutes for 10.4.22

Member Stephens made the motion to approve the Minutes and Member Hedrick made the second. Vice-Chair Flowers took a vote that was unanimous.

Voting yea: Vice-Chair John Flowers, Bradley Cummins, Bradley Hedrick, Tammy Hunsucker, and John Stephens

Administration of Oaths

Secretary Anderson administered the Oath to Kyle Garner. Vice-Chair Flowers then read the quasi-judicial statement.

Items of Consent

Member Stephens made the motion to approve the Orders for Case # 22-26 122 Front Street, Case # 22-27 305 Front Street, Case # 22-15 411 Front Street, and Case # 22-25 525 Front Street, and Member Hunsucker made the second. Vice-Chair Flowers took a vote that was unanimous.

Voting yea: Vice-Chair John Flowers, Bradley Cummins, Bradley Hedrick, Tammy Hunsucker, and John Stephens

New Business

1. Case #22-29; 214 Orange Street – New Siding

Secretary Anderson administered the Oath to the applicant, Christopher Cecil, 214 Orange Street.

Vice-Chair Flowers introduced Case #22-29 and Mr. Garner stated the owner wished to replace wood siding with fiber cement siding on the sides of the house. Mr. Garner entered in the record the following: on October 7th staff was informed of illegal work being done to the structure and after visiting the site with the building inspector it was determined that the original wood siding was being removed and fiber cement siding was being installed on the north facing exterior wall, without a Certificate of Appropriateness (COA) or other approval. Staff took photos of the exterior material that was removed and told the contractor to contact the owner and put a Stop-Work Order on the project until a COA was applied for and approved.

Member Cummins asked if the structure had been enveloped in wood to this date and Mr. Garner stated that it had been, except for a newer rear addition which has approved fiber cement siding.

Mr. Cecil took the podium and apologized to the Town for the illegal work, stating that did not know he needed to apply for a COA before beginning work. He had asked his contractor to repair rotten wood siding as it was found, and the rotten wood went to the top eaves on the north and south sides of the house. He also stated that there was no sheathing or barrier protection, and the house had been caulked horizontally and vertically which possibly caused the wood rot.

Member Stephens stated that typically the Board approved smooth siding rather than wood-grain, and the cost of materials was not factored in to their decision.

Member Cummins said that these cases were the most difficult as money had already been spent on materials, but the Board was charged with meeting the guidelines and if this were a new COA application it would not have been approved, one reason being the fiber cement was not the same thickness as the original clapboards and would give a different reveal than the original siding.

Member Hedrick verified the house would be repainted in the approved color and also expressed concern about the thickness of fiber cement siding as opposed to the original siding.

Vice-Chair Flowers stated that the house was plaqued and the guidelines stated that all existing wood siding should be saved as much as possible, the difference in the siding is $\frac{3}{4}$ " for the original siding as opposed to $\frac{1}{4}$ " for the proposed fiber cement, and the siding on the front and sides need to match.

Mr. Cecil requested an exception to the guidelines and Member Hedrick then read the guidelines pertaining to siding, and the Board discussed the "reveal" of the original siding as opposed to fiber cement siding and the effect of shadowing from the thinner fiber cement siding which would make the house look different.

Member Cummins said that these cases are the

most clear-cut as an HPC case could get and otherwise why have a historic district? Member Stephens said that if the case had come before the Board before the project had started it would not have been approved. Mr. Cecil again asked for an exception and stated that fiber cement had been approved for the addition to his house, and the Board explained that new additions and houses were differentiated from original historical structures by updated materials.

Hearing no further questions Vice-Chair Flowers asked for a motion for a Finding of Fact against Case #22-29 and Member Stephens made the following motion: Having reviewed the record and having considered all evidence submitted and oral testimony for case #22-29, move that the Commission conclude that the pending application failed to meet the following design standards under the Design Guidelines for the Beaufort Historic District and Landmarks: Wood Siding, Trim, and Ornament Guidelines 6.2.3, 6.2.10, 6.2.11

Member Cummins made the second and Vice-Chair Flowers took a vote.

Voting yea: Vice-Chair John Flowers, Bradley Cummins, Bradley Hedrick, Tammy Hunsucker, and John Stephens

Mr. Cecil asked for approval to replace the existing siding with matching new wood siding, and Mr. Garner explained that he would not have to request a COA to replace like-kind materials. Vice-Chair Flowers said that Mr. Cecil could obtain a Minor Works permit and not come before the Board for that request. Mr. Cecil stated that a mixture of cedar and pine siding had been removed and Vice-Chair Flowers explained that both would be approved in like-kind thickness as the original siding.

Vice-Chair Flowers then asked for a motion to deny a Certificate of Appropriateness (COA) for Case #22-29.

Member Stephens made a motion to deny the Certificate of Appropriateness based on the following: That the proposed project is incongruous with the special character of the historic district as a whole and that a Certificate of Appropriateness for case #22-29 not be issued for the proposed work.

Member Cummins made the second. Vice-Chair Flowers took a vote to deny the COA that was unanimous.

Voting yea: Vice-Chair John Flowers, Bradley Cummins, Bradley Hedrick, Tammy Hunsucker, and John Stephens

Vice-Chair Flowers then declared Case #22-29 closed.

Member Cummins asked the other Board members if a wood-grained hardi-board siding had been approved before and Vice-Chair Flowers stated it had but only on new structures. Mr. Garner clarified that each decision is separate based on relevant information and facts that are presented at hearings. Mr. Garner also went on record to state the applicant had received a COA for the business Cecil & Finch on Turner Street and he apparently had some knowledge of his house being in the historic district and COA requirements.

2. Case #22-28 214 Broad Street – Increase Size of Garage

Vice-Chair Flowers introduced Case #22-28 and the following applicant was sworn in:

Beth Bowen, 214 Broad Street, Beaufort

Mr. Garner explained that the original approved COA from 2020 included an 8' x 12' shed and Ms. Bowen was applying to increase the size to 13' x 30" to use as a workshop/garage. The current application includes the full plans including the structure height being below 16' which allows the structure within 5-foot setbacks on the side and rear, and the site plan showing the structure in the same location but with an expanded footprint.

Member Stephens asked if projects with larger additions of square footage were looked at to ensure the 50% rule of pervious/impervious surface was calculated, and Mr. Garner responded that it was an excellent question but that only applied to the RS-5 district and this house is in the R-8 district.

Member Cummins verified that the roof of the new structure would match the house. Vice-Chair Flowers asked if any neighbors had any comments, and the following witness was sworn in:

Laura Holland, 305 Moore St, Beaufort

Ms. Holland stated that she owned the adjoining property and her existing historic house, built before setbacks were put in place, is from 3” to 15” from the property line and Ms. Bowen’s proposed garage would be very close to her house. She was concerned with impact on her property and her privacy and property values, and if her own house met the normal setbacks Ms. Bowen’s garage would be 10’ from her house.

Member Stephens verified that Ms. Holland’s house was on the property line and stated that Ms. Bowen was meeting her setbacks, and Ms. Holland’s house did not as she was 3” off the property line and Ms. Bowen would be 5’ off the property line. Ms. Holland responded that Ms. Bowen’s proposed garage was a large non-essential structure and would impact her property. Member Stephens said that 5’ setbacks were all over town, and at any rate the issue was not in the HPC’s purview. Vice-Chair Flowers asked Mr. Garner if there were any zoning issues and Mr. Garner stated that if the accessory structure height was under 16’ the setback was 5’ from the property line and therefore there were no zoning issues.

Hearing no further questions Vice-Chair Flowers asked for a motion for a Finding of Fact for Case #22-28 and Member Stephens made the following motion: Having reviewed the record and having considered all evidence submitted and oral testimony for case #22-28, move that the Commission conclude that the pending application meets the following design standards under the Design Guidelines for the Beaufort Historic District and Landmarks: Building Placement 7.1.3, 8.1.13

Member Cummins made the second. Vice-Chair Flowers took a vote that was unanimous.

Voting yea: Vice-Chair John Flowers, Bradley Cummins, Bradley Hedrick, Tammy Hunsucker, and John Stephens

Vice-Chair Flowers then asked for a motion for a Certificate of Appropriateness for Case #22-28.

Member Stephens made a motion to approve the Certificate of Appropriateness based on the following: That the proposed project is not incongruous with the special character of the historic district as a whole and that a Certificate of Appropriateness for case #22-28 be issued for the proposed work.

Member Hedrick made the second. Vice-Chair Flowers took a vote that was unanimous.

Voting yea: Vice-Chair John Flowers, Bradley Cummins, Bradley Hedrick, Tammy Hunsucker, and John Stephens

Vice-Chair Flowers then declared Case #22-28 closed.

3. 2023 Historic Commission Meeting and Submittal Calendar

Member Stephens made the motion to accept the 2023 HPC Meeting and Submittal Calendar and Vice-Chair Flowers took a vote that was unanimous.

Voting yea: Vice-Chair John Flowers, Bradley Cummins, Bradley Hedrick, Tammy Hunsucker, and John Stephens

Commission / Board Comments

- a. Member Cummins asked if there had been any discussion regarding the recent CLG training in Swansboro.

- b. Member Hedrick asked Mr. Garner about the updated Design Standards, and Mr. Garner stated that elements missing from the Town’s standards plus new guidelines dealing with historic structures in floodplain areas would be incorporated into the Town of Beaufort’s new standards, at which time Beaufort would be the first community in the state with those updated standards.
- c. Vice-Chair Flowers requested copies and updates of Minor Works permits and Mr. Garner gave an update on those permits.

Staff Comments

- a. Mr. Garner stated that the Town may schedule another educational series in February or March 2023 to give information to those living in the historic district, and he has been in discussions with Public Works to put up signs designating the Historic District which may be
- b. He also updated the Board regarding a code enforcement issue on Moore Street.
- c. Mr. Garner also notified the Board about a potential cemetery workshop with the State Historic Preservation Office (SHPO) in the spring of 2023 and possibly bringing in an expert to repair some of the damaged headstones in the Old Burying Ground.
- d. He discussed a video seminar given by SHPO which covered “apotropaic” or “witches’ marks” which were symbols lightly carved into the wood by carpenters to keep bad spirits and witches out.

Adjourn

Vice-Chair Flowers made the motion to adjourn and Member Stephens made the second. Vice-Chair Flowers took a vote that was unanimous.

Voting yea: Vice-Chair John Flowers, Bradley Cummins, Bradley Hedrick, Tammy Hunsucker, and John Stephens

Vice-Chair Flowers declared the November 1, 2022 meeting adjourned.

Vice-Chair, John Flowers

Board Secretary, Laurel Anderson



Town of Beaufort, NC

701 Front St. - P.O. Box 390 - Beaufort, N.C. 28516
252-728-2141 - 252-728-3982 fax - www.beaufortnc.org

**Town of Beaufort Historic Preservation Commission
6:00 P.M. December 6, 2022 – 614 Broad Street – Train Depot**

AGENDA CATEGORY: Consent

SUBJECT: Approval of the Orders for 214 Broad Street & 214 Orange Street – Certificates of Appropriateness

BRIEF SUMMARY:

As part of the new General Statutes (160D), prior to Evidentiary Hearing Orders being signed and sent to the applicant/property owners, the Board in which conducted the hearing is to review the order for accuracy.

The staff has consulted with the Town Attorney and now asks that the Historic Commission Members review the orders for such accuracy and be prepared to make a motion to recommend approval of the Order or to approve with Commission recommended changes.

REQUESTED ACTION:

Review the order for such accuracy and be prepared to make a motion to recommend approval of the Order or to approve with Commission recommend changes

EXPECTED LENGTH OF PRESENTATION:

0 Minutes (Presentation from Staff)

SUBMITTED BY:

Kyle Garner, AICP Planning Director

BUDGET AMENDMENT REQUIRED:

N/A



Town of Beaufort
701 Front St. • P.O. Box 390 • Beaufort, N.C. 28516
252-728-2141 • 252-728-3982 fax
www.beaufortnc.org

December 6, 2022

Beth Bowen
109 Greensview Drive
Cary, North Carolina 27518

RE: Case # 22-28 214 Broad Street - Increase Size of Approved Shed to Workshop/Garage

Dear Ms. Bowen,

Beaufort's Historic Preservation Commission wishes to thank you for your recent application for a Certificate of Appropriateness regarding the property referenced above which is in the Town's Historic District. We appreciate you taking the time to come before the Commission, as well as your willingness to work with us to preserve the distinctive character of Beaufort. Your commitment will help ensure the many historic and cultural resources that we enjoy today will be preserved for future generations.

You have been issued a Certificate of Appropriateness for your project as specified on the enclosed certificate. Please read it carefully. As you proceed with your project, you must comply with all the specifications stated, including provisions in the relevant Historic District Guidelines enumerated on the certificate. Please note the COA must be visibly displayed at the site during the entire duration of the project. Also note that a building permit with the Town may be needed depending on the scope of the work.

Your certificate is valid for the work which must begin within six (6) months from the date of issuance of the COA by the Commission and must be completed no later than one year thereafter. An extension of the COA can be granted upon the Town receiving a written request from the applicant prior to the application expiration date. An extension may only be granted once for a time period of six additional months if the work has been started but not completed within the one-year validation period. Upon completion of your project please contact our office in case an inspection of the project is required.

Thank you for the thought and care that you have dedicated to your project. Your contribution to the preservation of Beaufort's Historic District is greatly appreciated.

Sincerely,

Joyce McCune, Chair
Beaufort Historic Preservation Commission

Enclosed: COA Certificate

Mayor Sharon Harker
Commissioner John Hagle • Commissioner Marianna Hollinshed
Commissioner Bucky Oliver • Commissioner [8] win Cooper • Commissioner Bob Terwilliger
Town Mar [8] Todd Clark



TOWN OF BEAUFORT, NC
ORDER GRANTING A CERTIFICATE OF APPROPRIATENESS

The Historic Preservation Commission for the Town of Beaufort, N.C. (“HPC”), having held an evidentiary hearing on November 1, 2022 to consider a Certificate of Appropriateness (“COA”) application submitted by Ms. Beth Bowen for **CASE # 22-28 214 BROAD STREET - INCREASE SIZE OF APPROVED SHED TO WORKSHOP/GARAGE** and having heard all of the evidence, testimony, and arguments presented during the evidentiary hearing on this item and having the material(s) submitted to the HPC from the applicant, makes the following CONCLUSION:

Based upon the testimony, evidence and record before the HPC on November 1, 2022, we find that the application submitted currently meets the following design standards under the Design Guidelines for the Beaufort Historic District & Landmarks [revised 2008]:

7.1.3. Place outbuildings and accessory structures in side and rear yards. Avoid locations that obscure the principal building’s prominent architectural features or significant site features.

8.1.13. New tool sheds, swimming pools and other modern yard features should be located in areas not seen from public view.

THEREFORE, IT IS ORDERED based on the application submitted, the testimony given during the evidentiary hearing and the foregoing findings of fact, the HPC concludes that the proposed project is congruous with the special character of the Historic District as a whole and that a Certificate of Appropriateness be **ISSUED** for **CASE # 22-28 214 BROAD STREET - INCREASE SIZE OF APPROVED SHED TO WORKSHOP/GARAGE**.

This the 6th day of December, 2022

Joyce McCune, Chair
Beaufort Historic Preservation Commission

NOTE: If you are dissatisfied with the decision of this Board, an appeal may be taken to the Beaufort Board of Adjustment within 30 days after the date this order is served on you.



Town of Beaufort
701 Front St. • P.O. Box 390 • Beaufort, N.C. 28516
252-728-2141 • 252-728-3982 fax
www.beaufortnc.org

December 6, 2022

Christopher Cecil
214 Orange Street
Beaufort, North Carolina 28516

RE: Case # 22-29 214 Orange Street – Replace Wood Siding with Fiber Cement Siding

Dear Mr. Cecil;

Beaufort's Historic Preservation Commission wishes to thank you for your recent application for a Certificate of Appropriateness regarding the property referenced above which is in the Town's Historic District. We appreciate you taking the time to come before the Commission, as well as your willingness to work with us to preserve the distinctive character of Beaufort.

The Beaufort Historic Preservation Commission conducted an evidentiary hearing on your application on November 1, 2022. Unfortunately, your application for a Certificate of Appropriateness for your project as specified in the enclosed order has been denied.

As stated in the Town's Land Development Ordinance, an appeal may be taken to the Board of Adjustment from the Historic Preservation Commission's actions in granting or denying any application for a Certificate of Appropriateness. Appeals may be taken to the Board of Adjustment by any aggrieved party and shall be taken within 30 days after the decision of the Historic Preservation Commission is signed by its Chairman and entered into the records of the Commission. You may call the Planning and Inspections Office at (252) 728-2142 to receive further details on this appeal process.

Thank you for the thought and care that you have dedicated to your project. Your contribution to the preservation of Beaufort's Historic District is greatly appreciated.

Sincerely,

Joyce McCune, Chair
Beaufort Historic Preservation Commission

Enclosed: COA Certificate



TOWN OF BEAUFORT, NC
ORDER GRANTING A CERTIFICATE OF APPROPRIATENESS

The Historic Preservation Commission for the Town of Beaufort, N.C. (“HPC”), having held an evidentiary hearing on November 1, 2022 to consider a Certificate of Appropriateness (“COA”) application submitted by Christopher Cecil for **CASE # 22-29 214 ORANGE STREET - REPLACE WOOD SIDING WITH FIBER CEMENT SIDING** and having heard all of the evidence, testimony, and arguments presented during the evidentiary hearing on this item and having the material(s) submitted to the HPC from the applicant, makes the following CONCLUSION;

Based upon the testimony, evidence and record before the HPC on November 1, 2022, we find that the application submitted does **not** meet the following design standards under the Design Guidelines for the Beaufort Historic District & Landmarks [revised 2008]:

6.2.3. Replace historic wood elements only where the original is too deteriorated to repair. If replacement is necessary, use new replacement wood that matches the original as closely as possible in all properties: shape, profile, texture, and detailing. The deteriorated or damaged condition should be documented. Replacement of these features in kind and according to the guidelines does not normally require a COA.

6.2.10. The HPC may allow the replacement of existing substitute siding with new substitute siding (such as cement fiber siding) if the proposed replacement will be more in keeping with the original appearance of the structure. Substitute siding with a simulated wood grain will not be permitted.

6.2.11. The use of fiber cement siding may be approved for new structures, non-historic structures and additions to historic structures not visible from public streets or waterways.

THEREFORE, IT IS ORDERED based on the application submitted, the testimony given during the evidentiary hearing and the foregoing findings of fact, the HPC concludes that the proposed project is **not** congruous with the special character of the Historic District as a whole and that a Certificate of Appropriateness be **DENIED** for **CASE # 22-29 214 ORANGE STREET – REPLACE WOOD SIDING WITH FIBER CEMENT SIDING**.

This the 6th day of December, 2022

Joyce McCune, Chair
Beaufort Historic Preservation Commission

NOTE: If you are dissatisfied with the decision of this Board, an appeal may be taken to the Beaufort Board of Adjustment within 30 days after the date this order is served on you.



Town of Beaufort, NC

701 Front St. - P.O. Box 390 - Beaufort, N.C. 28516
252-728-2141 - 252-728-3982 fax - www.beaufortnc.org

**Town of Beaufort Historic Preservation Commission Regular Meeting
6:00 PM Tuesday, December 6, 2022 – 614 Broad Street – Train Depot**

AGENDA CATEGORY: New Business
SUBJECT: Case # 22-30 400 Front Street - Signage

BRIEF SUMMARY:

Bimini Twist wishes to install their signage for 400 Front Street that was approved for an overall signage plan. They have submitted their colors and text.

REQUESTED ACTION:

Conduct Quasi- Judicial Hearing

EXPECTED LENGTH OF PRESENTATION:

5 Minutes

SUBMITTED BY:

Kyle Garner

BUDGET AMENDMENT REQUIRED:

N/A



BHPC STAFF REPORT



To: BHPC Members
From: Kyle Garner, Planning Director
Date: November 17, 2022
Case No. 22-30

Request: Installation of a new Sign
Applicant: Bimini Twist
400 Front Street
Beaufort

Property Information:

Owners: Dr. Sameh K. Toma, Cindy Toma & Ray Travino
Location: 400 Front Street
PIN#: 730617102064000

Project Information:

This request is part of the overall signage plan for 400 Front Street which allowed for a 15.5 sq. ft. sign per side. (One on Front Street and one on the waterside at 15.5 sq. ft. each.) These signs are included in that total square footage of 124 sq. ft. that was approved in November of 2020. The current request concerns the design, color, and material.

Proposed work:

- See Attached Information from Applicant.

Material:

- See Attached Information from Applicant. Color samples have been submitted by the applicant and will be presented at the hearing or each member may stop by the Planning office to review.

Color:

See Attached Description from Applicant.

Attachments:

- Area map
- List of adjacent property owners used for mailing notifications
- COA application and supporting materials supplied by applicant

Signage Guidelines: (Page 119)

8.6.1. Use traditional materials found in the district, such as wood and metal for new signage. Substitute Materials that have the appearance of wood are allowed. Plastic signs, flashing signs, or portable mobile signs, except those listed in item 9, are not allowed in the historic district. Interior neon signs larger than 10” by 18” that are located within five (5) feet of a window or glass door on an exterior wall and are so placed as to be seen from the outside are not allowed. INTERNAL GLASS MOUNTED SIGNS ARE NOT SUBJECT TO BHPC REVIEW.

8.6.2. Place signs so that they do not visually overwhelm the building or streetscape or damage or obscure character defining architectural details. Recognize that maximum signage allowances granted by the Beaufort Zoning Ordinance may be inappropriate in the context of the building or site under review.

8.6.3. Signs on commercial buildings are preferred to be in a signboard frieze located above the display windows. In this location the sign serves as a boundary between the upper and lower façade.

8.6.5. Use simple, clear graphics and lettering styles in sign design.

BHPC Case 22-30 400 Front Street - Signage

1.

Legend

- NCHPOpoints
- Tax_Parcel_Data

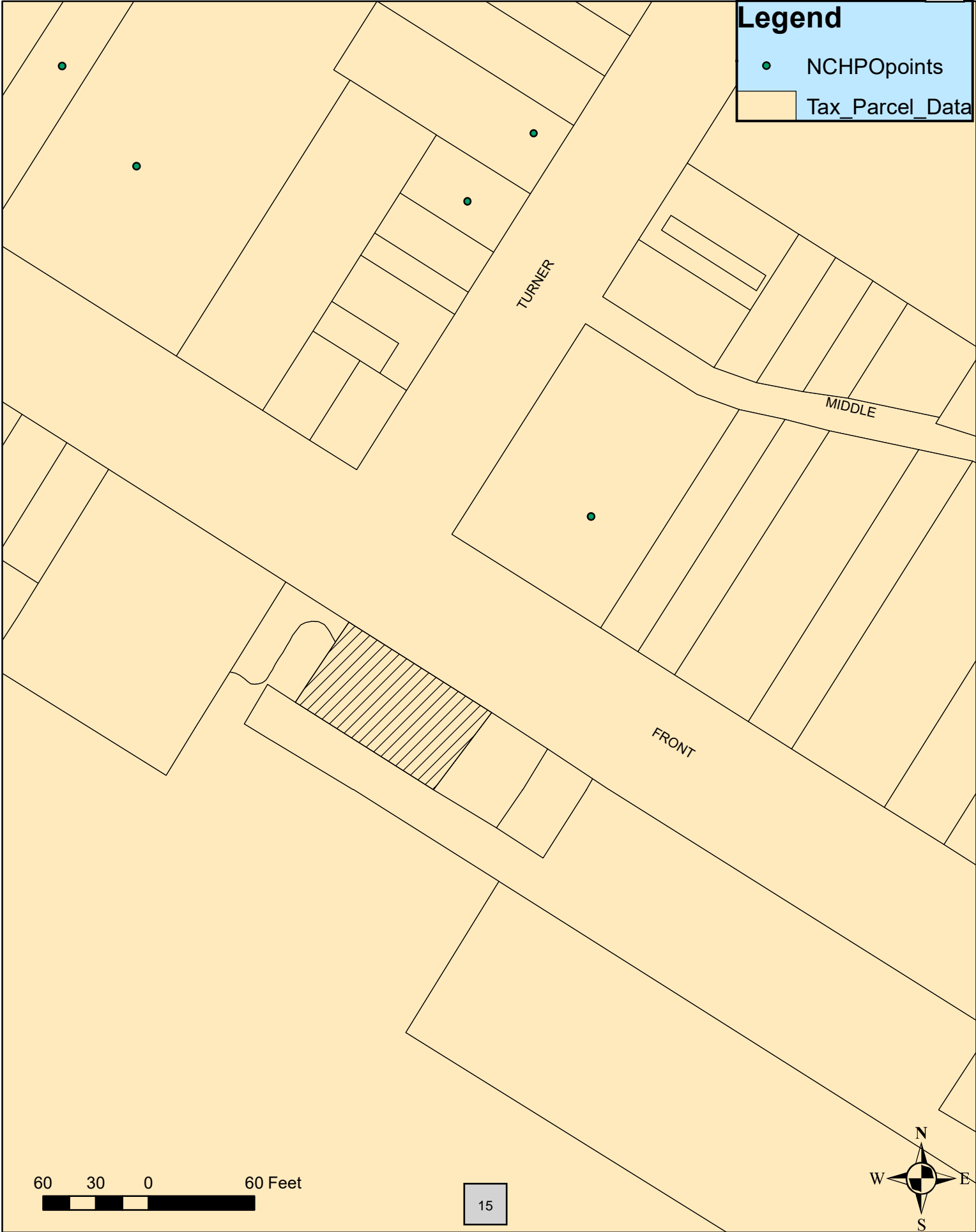

60 30 0 60 Feet

15

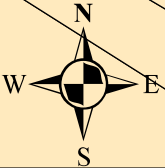

<u>OWNER</u>	<u>MAIL_HOUSE</u>	<u>MAIL_ST</u>	<u>MAIL_CITY</u>	<u>IL_ST</u>	<u>MAIL_ZI</u>	<u>MAIL_ADD2</u>
400 FRONT ST PROPS LLC ETAL	400-200	ASHVILLE AVE	CARY	NC	27518	
DUNCAN OF BEAUFORT LLC	325	FRONT STREET	BEAUFORT	NC	28516	
FLYBRIDGE VENTURES LLC	5309	SENSATION WEIGH	BEAUFORT	NC	28516	
WHEATLY PROPERTIES LLC			BEAUFORT	NC	28516	PO BOX 360

Kyle Garner

From: Brian Kennedy <brian@stoett.com>
Sent: Monday, November 14, 2022 3:23 PM
To: Kyle Garner
Subject: Fwd: Reply To This

Jeremy has this!! I don't think I ever sent this to you!! To make sure we want the top option!! The one with the blue border around it!!

Sent from my iPhone

Begin forwarded message:

From: Brian Kennedy <brian@stoett.com>
Date: May 11, 2021 at 4:04:45 PM EDT
To: j.ganey@beaufortnc.org
Subject: Fwd: Reply To This

Please use the top option for approval, this is for Bimini Twist at 400 Front St. space 106

----- Forwarded message -----
From: <art.advancedsignsnc@gmail.com>
Date: Tue, May 11, 2021 at 1:21 PM
Subject: RE: Reply To This
To: Brian Kennedy <brian@stoett.com>

Ok, here are two options.

From: Brian Kennedy <brian@stoett.com>
Sent: Tuesday, May 11, 2021 9:49 AM
To: art.advancedsignsnc@gmail.com
Subject: Re: Reply To This

We would like to have Bimini Twist spelled out side by side not on top of each other. Please use the font i gave you, if the knot can be added please do, if not no worries just Bimini Twist is fine. We would like the background to be SW0068 Copen Blue the border and letters to be solid SW6244 Naval. My name is Brian Kennedy My cell is 336-736-0306.

On Tue, May 11, 2021 at 12:36 PM <art.advancedsignsnc@gmail.com> wrote:

BIMMINI TWIST

BIMMINI TWIST



Town of Beaufort, NC

701 Front St. - P.O. Box 390 - Beaufort, N.C. 28516
252-728-2141 - 252-728-3982 fax - www.beaufortnc.org

**Town of Beaufort Historic Preservation Commission Regular Meeting
6:00 PM Tuesday, December 6, 2022 – 614 Broad Street – Train Depot**

AGENDA CATEGORY: New Business
SUBJECT: Case # 22-31 214 Orange Street – Accessory Structure

BRIEF SUMMARY:

The applicant wishes to modify the existing rear accessory structure/garage. The applicant will submit evidence at the December 6th meeting.

REQUESTED ACTION:

Conduct Quasi- Judicial Hearing

EXPECTED LENGTH OF PRESENTATION:

5 Minutes

SUBMITTED BY:

Kyle Garner

BUDGET AMENDMENT REQUIRED:

N/A



BHPC STAFF REPORT



To: BHPC Members
From: Kyle Garner, Planning Director
Date: November 18, 2022
Case No. 22-31

Request: To modify the existing rear accessory structure/garage (COA- March 1999)
Applicant: Christopher Cecil
 214 Orange Street
 Beaufort, NC 28516

Property Information:

Owners: Same
Location: Same
PIN#: 730617114169000

Project Information: 1999 - A COA was granted for replacement of windows, door erecting a picket fence, replacing the siding, roof and reconstructing a new addition on the rear and constructing a storage shed in the rear of the house.

2003 - A plaque was approved for the house.

2010 – A COA was approved for paint for the house and garage (5001-1B Woodlawn Silver Brook)

2018 – A COA was approved for a rear addition to the existing main structure.

Proposed work:

- See Attachment from Applicant

Material:

- After discussion with the applicant on November 15, 2022, they will be submitting their materials as evidence during the hearing on December 6th as either a PowerPoint presentation or PDF's. The applicant has stated that the windows, doors, and paint will match the existing structure.

Color:

See Attached Description from Applicant.

Attachments:

- Vicinity Map
- List of adjacent property owners used for mailing notifications
- COA application and supporting materials supplied by applicant.
- Photos taken in 2010 of Accessory Structure/Garage

Wood Siding, Trim, and Ornament Guidelines

6.2.11. The use of fiber cement siding may be approved for new structures, non-historic structures, and additions to historic structures not visible from public streets or waterways.

Window and Door Guidelines

6.4.7. New windows must match original in overall size and opening area and should have three dimensional muntin's with either true divided lights (TDL) or three-dimensional grilles on both the interior and exterior sides (SDL). Snap-in grilles or grilles between glass are not appropriate for windows visible from public view.

6.4.10. New window and door openings shall not alter the historic character of the building or cause damage to historic materials or other significant architectural features. They must be detailed and sized to be compatible with the existing structure.

Paint and Exterior Colors Guidelines

6.7.1. Repainting a building in the same color, including minor touch-up painting, and the cleaning of existing painted surfaces do not require a COA, nor does re-lettering a painted sign in the same color.

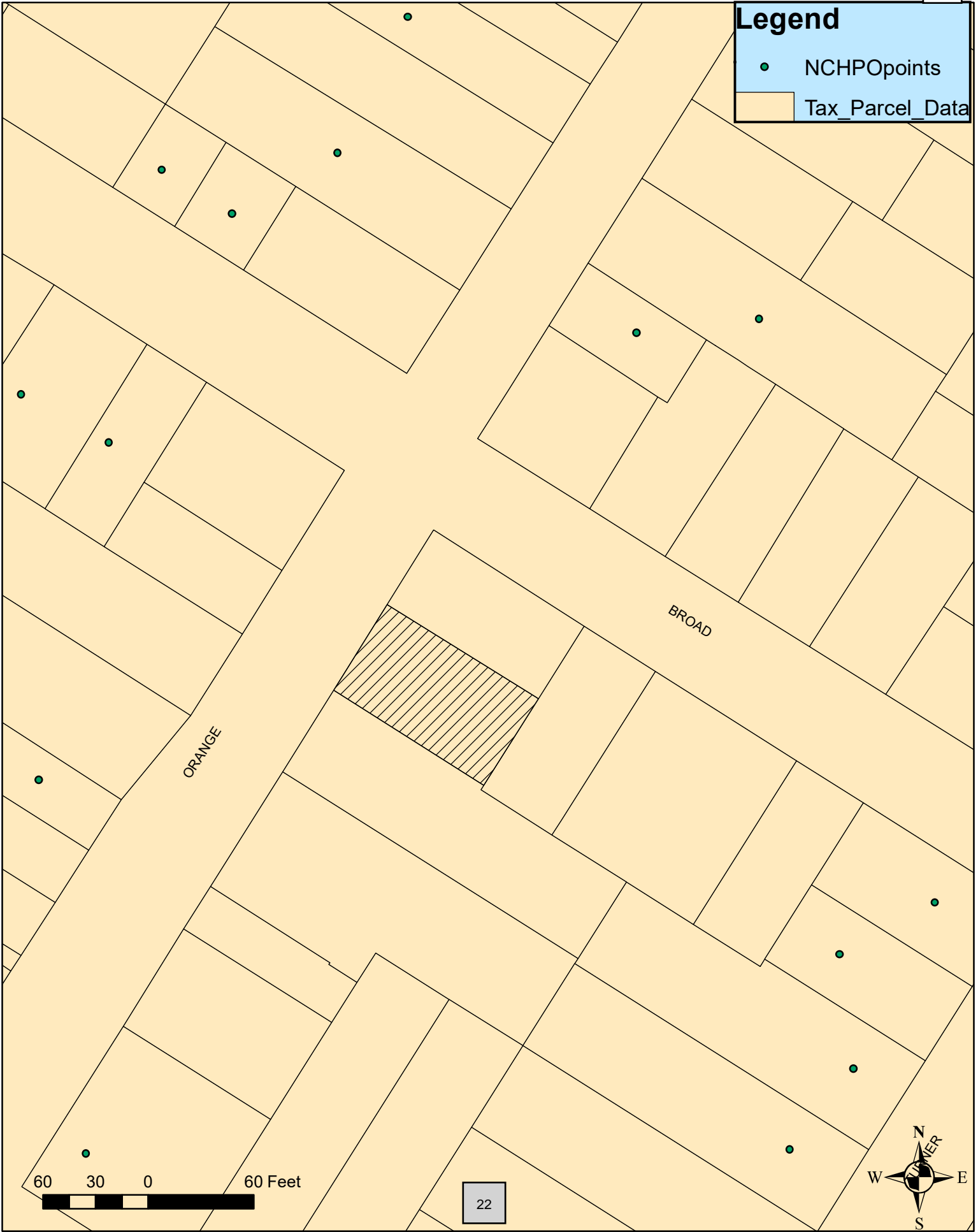

Legend

- NCHPO points
- Tax_Parcel_Data

60 30 0 60 Feet

22

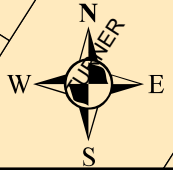

<u>OWNER</u>	<u>AIL_HOU</u>	<u>MAIL_ST</u>	<u>MAIL_CITY</u>	<u>L_ST</u>	<u>AIL_Z</u>	<u>MAIL_ZI</u>	<u>MAIL_ADD2</u>
BARNES,GAIL RACKLEY	385	CHEROKEE AVE SE	ATLANTA	GA	2230	30312	
BOWEN,MARY ELIZABETH WARD	590	NEW WAVERLY PLACE	CARY	NC		27518	SUITE 120
MAGOWAN,STEVEN F ETUX JOANNE O	303	CHESAPEAKE RIDGE #1C	NORTH EAST	MD		21901	
OGUS,RICHARD C ETUX MARY H	306	BROAD STREET	BEAUFORT	NC		28516	
ORANGE STREET BEAUFORT LLC	500	EAST BLVD	CHARLOTTE	NC	5110	28203	C/O CHRISTOPHER & RUTH CECIL
WHEELER,DAVID S ETUX WINNIFORD	215	ORANGE STREET	BEAUFORT	NC	2134	28516	
WILLIS,ADAM DANIEL	2103	HIGHWAY 101	BEAUFORT	NC		28516	







CERTIFICATE OF APPROPRIATENESS APPLICATION FOR PROJECTS WITHIN THE BEAUFORT HISTORIC DISTRICT



Instructions:

Please complete the application below and include all attachments as noted on page 2 of this application along with a **\$250.00 application fee** and return to the Beaufort Town Hall; 701 Front Street or P.O. Box 390, Beaufort, N.C. 28516. Incomplete applications will not be processed and **will be** returned to the applicant. Please contact Town Hall at 252-728-2142 if there are any questions.

APPLICANT/OWNER INFORMATION

Please print!

Applicant Name: CHRIS CECIL

Applicant Address: 500 ~~ORANGE~~ EAST Blvd, Charlotte, Nc 28203

Business Phone: 704-560-9288 Email/Cell: Chris@biltmorefamilyoffice.com

Property Owner Name: ORANGE ST BEAUFORT, LLC

Address of Property: 214 ORANGE ST., BEAUFORT, Nc 28516

Phone Number: 704-560-9288 Email/Cell: Chris@biltmorefamilyoffice.com

PROJECT INFORMATION

Detailed description of the Proposed Project (please attach additional pages if necessary):

SEE ATTACHED building Permit. Current GARAGE is unusable due to its Access on Property, As well AS its NARROW depth. The structure is NOT Accessible by car. Plan to remove rotten exterior, and convert interior to golf-CART garage and STUDIO. Plan will add A larger overhang to greatly enhance Aesthetics, and to All Materials, color to Match existing Home.

Estimated Cost of Project: \$ 25,000=

GARAGE
Year House Built: 1990
HOUSE Built 1887/1990/2018

Chris Cecil
Applicant Signature

10/17/22
Date

Property Owner Signature (if different than above)

Date

An application fee of \$250.00, either in cash, money order, or check made payable to the "Town of Beaufort" must accompany this application (a credit or debit card payment can be made in person at Town Hall). The complete application, payment, and supporting material must be received by Town Staff by the posted submittal dates noted on the Historic Preservation's calendar found on the Town's website at www.beaufortnc.org. The Commission meets regularly on the first Tuesday of the month unless it is a holiday.

OFFICE USE ONLY

Received by: _____

Reviewed for Completeness: _____

Date: _____

Date Deemed Completed and Accepted: _____

REQUIRED ATTACHMENTS FOR A CERTIFICATE OF APPROPRIATENESS (COA)

Please provide the following along with this checklist form, with the COA application:

1. Items required for ALL projects:

- A list all adjacent property owners (with mailing addresses).
- Photographs of the streetscape, the site, and existing buildings to be impacted.
- A site plan showing dimensions of both existing and proposed conditions.
- A description of all building and/or landscaping materials (such as siding, roofing, windows, doors, signs, planting materials, etc.).

2. Items required as applicable to project:

- A description of any planned demolition.
- An indication of all trees to be replaced and/or removed.
- A landscaping plan indicating major planting materials. *N/A*
- Exterior paint color sample/color swatch(s) for projects involving any change of exterior paint color(s) only.
- All types of building material samples.
- If a project involves the reconstruction of an earlier feature of a historic structure, documentation of the prior existence of such feature. *N/A*

3. Additional items required (only) for new Signage:

- A drawing or true likeness of the new sign indicating the dimensions of the sign (and any supporting post or hanging apparatus if applicable). The lettering style and colors of the sign should also be on the drawing or likeness. *N/A*
- A paint sample/color swatch of all color(s) to be used both on the sign and on the post or hanging apparatus if applicable.

4. At least **one set of materials, in color**, that are to be evaluated by the Commission should be submitted with the application. An electronic or digital file of the work should also be submitted. Please contact Town Staff to see what electronic or digital file can be submitted.

5. The applicant or a representative for the applicant **must be present at the meeting** for action to be taken on the application. If it is not possible for the applicant or their representative to be present at the assigned meeting, please contact Town Staff as soon as possible.

A COA is valid for a period of six (6) months and may be renewed for an additional six months via written request to Town Staff from the applicant (please state all reasons why the extension is needed). If work has not begun or a building permit for the project has not been obtained within the six-month period, the COA is deemed invalid. The COA is considered issued once the Commission approves the application at their meeting.

If there are questions regarding what should or should not be included with this application, please contact Town Staff at 252-728-2142 or at k.garner@beaufortnc.org.



BUILDING PERMIT APPLICATION

For all Residential and Commercial Requests

Residential application

Commercial application

The following information is required on all permit applications.
Additional information may be included to ensure that all state and local laws are complied with.

Property Owner Information	*Contractor/General Contractor/Agent/Other
Name: 214 Orange LLC	Bus./Cont. Name: Chris Cecil, Owner
Phone(H/O): (include area code)	Phone(O): (include area code)
Phone (Cell): 704-560-9288	Phone (Cell): 704-560-9288
Address: 500 East Blvd	Address: 500 East Blvd
City/State/Zip: Charlotte, NC 28203	City/State/Zip: Charlotte, NC 28203
Owner Email: chris@biltmorefamilyoffice.com	Contractor Email: chris@biltmorefamilyoffice.com
	State License #: N/A Other St. License. #: N/A

Project Manager: (Name) Chris Cecil Phone # 704-560-9288

Construction site address: 214 Orange Street, Beaufort, NC 28516

Construction value: \$ 25,000.00	NC Lien #	Est. start date: 12/1/22
Type of Building: <input type="checkbox"/> New <input checked="" type="checkbox"/> Existing <input type="checkbox"/> Addition <input type="checkbox"/> N/A	Equipment: <input checked="" type="checkbox"/> New <input type="checkbox"/> Existing <input type="checkbox"/> Addition <input type="checkbox"/> N/A	
Occupancy: <input type="checkbox"/> A-1 <input type="checkbox"/> A-2 <input type="checkbox"/> A-3 <input type="checkbox"/> A-4 <input type="checkbox"/> A-5 <input type="checkbox"/> B <input type="checkbox"/> E <input type="checkbox"/> F-1 <input type="checkbox"/> F-2 <input type="checkbox"/> H-1 <input type="checkbox"/> H-2 <input type="checkbox"/> H-3 <input type="checkbox"/> H-4 <input type="checkbox"/> H-5 <input type="checkbox"/> I-1 <input type="checkbox"/> I-2 <input type="checkbox"/> I-3 <input type="checkbox"/> I-4 <input type="checkbox"/> M <input checked="" type="checkbox"/> R-1 <input type="checkbox"/> R-2 <input type="checkbox"/> R-3 <input type="checkbox"/> R-4 <input type="checkbox"/> S-1 <input type="checkbox"/> S-2 <input type="checkbox"/> U		
Type of Construction: <input type="checkbox"/> IA <input type="checkbox"/> IB <input type="checkbox"/> IIA <input type="checkbox"/> IIB <input type="checkbox"/> IIIA <input type="checkbox"/> IIIB <input type="checkbox"/> IV <input type="checkbox"/> VA <input type="checkbox"/> VB		
Property Use: <input checked="" type="checkbox"/> Single-Family <input type="checkbox"/> Two Family <input type="checkbox"/> Townhouse <input type="checkbox"/> Apartment <input type="checkbox"/> Condominium <input type="checkbox"/> Other (Library, Office, etc.)		
***Total (new) Heated area:	***Total (new) Unheated area:	***No. of stories: 1.00
1 st Floor sq.ft.	Carport 0 sq.ft.	***Bldg. height: Existing Roof to Remain
2 nd Floor sq.ft.	Garage -187 sq.ft.	***Accessory dimensions:
3 rd Floor sq.ft.	Porch/Deck 0 sq.ft.	***Accessory height: None
Other 353.00 sq.ft.	Porch/Deck 0 sq.ft.	***CAMA Permit #: <input type="checkbox"/> Yes <input checked="" type="checkbox"/> No (please include copy)
	Shed/Outbuilding 0 sq.ft.	***Historic District: <input checked="" type="checkbox"/> Yes <input type="checkbox"/> No (please include a copy of the documents below)
	Other 0 sq.ft.	Certificate of Appropriateness: <input type="checkbox"/> Yes <input type="checkbox"/> No Minor Works: <input type="checkbox"/> Yes <input checked="" type="checkbox"/> No
***Total: 353 sq.ft.	***Total: -187 sq.ft.	*** Total (new) square footage: 0 sq. ft.

*** Required information for most structural permits.

General description of work to be performed: (Please print and be specific)

Current garage structure is unusable due to narrow access and narrow depth (too small to fit vehicle), and exterior siding is rotten. Plan is to remove exterior front and right-side exterior walls and replace with inset walls to create a small aesthetic overhang, create a cart-size garage on left-side, and workroom/art studio on right-side with bathroom. The structure will add new windows and doors. Roof and roof structure to remain. Project will require new plumbing/electrical/HVAC to be provided by licensed contractor with applicable permits. These changes will greatly enhance the aesthetics of the structure, and allow it to be used by the homeowner. In its current state, it is unusable as a garage. The windows, doors, exterior siding, paint color, and all finishes will be completed to match existing home. This permit replaces any open and existing permits for this structure. COA to be submitted simultaneously.

(May attach another page if necessary to complete the description.)

PLEASE READ BEFORE SIGNING. By signing this application, I certify all information within this application is correct and all work will comply with the applicable N.C. State Building Codes and all other applicable State and local codes, ordinances, and regulations. The Town's Inspection Department will be notified **immediately** of any change in the approved application and/or specifications for the project permitted. A final inspection shall be called for by the owner, contractor, agent, or other individual listed below within ten (10) working days of substantial completion of project. Unless restrictions apply, construction must begin within six (6) months of the permit issue date or the permit becomes null and void.

Owner, General Contractor, or Agent Signature
Chris Cecil, Manager & sole-owner Orange Street Beaufort, LLC
Print or type name above

10/17/22

Date of Signature
704-560-9288
Phone

Property Cards

RT 590002.014.000 ORANGE STREET BEAUFORT LLC 2023 426,218 MKT CARD 001
 PID R 7306.17.11.4169000 426,218 PY Val USE 274,865 LAND 001
 LISTER 8/16/2022 JMS 500 EAST BLVD CHARLOTTE NC 28203 5110 DEF 135,490 BLDG 001
 TWP BEAUFORT CITY BEAUFORT FIRE DEED 1576 245 AICUZ RESCUE BEAUFORT RESCUE OTHER 15,863 XFOB 003
 LOT BLK PL BK/PG PLAT ADDRESS 0000214 ORANGE ST BEAUFORT 28516
 NBHD 59000200 USE 000100 RESIDENTIAL DEED 1576 245 AICUZ PRINTED 9/30/2022 BY ALLENN
 LEGAL: L104 TOWN OF BEAUFORT

BUILDING CHARACTERISTICS for BldgSeq# 001 (Item# 001)

Code	Description	Code	Description	Code	Description	Code	Description
MODL 01	SNG FAMILY	BVAL	00001C SNG FAMILY	ARCH	10 CONVENTL	QUAL	0C C GRADE
FINDN 02	CONC BLOCK	FRME	N/A	WINDO	N/A	EXW1	12 RES WOOD
HEAT 10	HEATPUMP	A/C	N/A	RSTR	03 GABLE	EXW2	.
INT1 03	PLASTER	INT2	05 DRYMALL	INT2%	10	RCV1	03 COMP SHINGL
KTCH	N/A	DPRT	02	BATH	1.00	FLR1	14 CARPET
+/-	10 PLUS 10	FRPL	N/A	UD-3	N/A	ROOM	
COND 0A	AVERAGE	INSP	04 ESTIMATED	UD-4	N/A	HTFL	04 ELECTRIC
				UD-9	N/A	UD-9%	AYB 1887
							TRVERSE EYB 1997

Subarea	Actual	Adj	Heated	Prime	Rate	Value	%Good
TWO STO	672	1344	1344	672	159.56	107226	76.00
PORCH	147	51			27.68	4069	76.00
E STO	432	432	432	432	79.78	34465	76.00
CK	112	28			19.95	2234	76.00
E STO	352	352	352	352	79.78	28083	76.00
LUMP					2200	76.00	
TOTAL	1715	2128			83.77	178277	
TOTAL	2207				135,490		

RT 590002.014.000 ORANGE STREET BEAUFORT LLC 2023 426,218 MKT CARD 002
 PID R 7306.17.11.4169000 426,218 PY Val USE 274,865 LAND 001
 LISTER 8/16/2022 JMS 500 EAST BLVD CHARLOTTE NC 28203 5110 DEF 135,490 BLDG 001
 TWP BEAUFORT CITY BEAUFORT FIRE DEED 1576 245 AICUZ RESCUE BEAUFORT RESCUE OTHER 15,863 XFOB 003
 LOT BLK PL BK/PG PLAT ADDRESS 0000214 ORANGE ST BEAUFORT 28516
 NBHD 59000200 USE 000100 RESIDENTIAL DEED 1576 245 AICUZ PRINTED 9/30/2022 BY ALLENN
 LEGAL: L104 TOWN OF BEAUFORT

SALES

IN Q	RC	M	V	Sale Date	Sale Price	Number	Type	Description	Issued	Schd	Comp	Revisit	Act	Comp	Amount
WD U	I			5/19/2017	455,000	22-00050	PRMT	RENOVATION	1/01/2022	3/01/2023					15,000
WD C	I			9/12/2002	390,000	1900031		C/O ISSUED	7/19/2019						20,000
WD U	I			1/21/1999	135,000	19-00031	ADDI	ADDITION	1/17/2019						20,000

EXTRA FEATURES

Seq	Bldg	Code	Description	Length	Width	Height	#Units	UT	Qty	Qual	UTPrice	Year	Adj1	Adj2	Adj3	Adj4	%Good	Value	
001	000040	GARAGE/UNFINISH/		30	18		1	0C	540.000	SF	1	0C	.95	1.00	1.00	1.00	100.00	12,907	
002	00046B	PATIO-ABOVE AVG		260	1		1	0B	260.000	SF	1	0B	5.600	0000	.95	1.00	1.00	100.00	1,383
003	00040A	PAVING EXCELLEN		18	10		1	0A	180.000	SF	1	0A	9.200	0000	.95	1.00	1.00	100.00	1,573

Seq	Zone	Code	Use	Description	#Units	UT	UTPrice	Adj1	Adj2	Adj3	Adj4	Fadj	Dadj	Nbhd	Adj	Eff	Rate	Value
1	Front	Depth	Back	FT	RESIDENTIAL LOT													
57	100	60	57.000	FF	5,400.000	.90	1.00	1.00	1.00	1.21	.82	1.000	1.000	4,822.192	274,865			

Property Map & Adjoining Owners

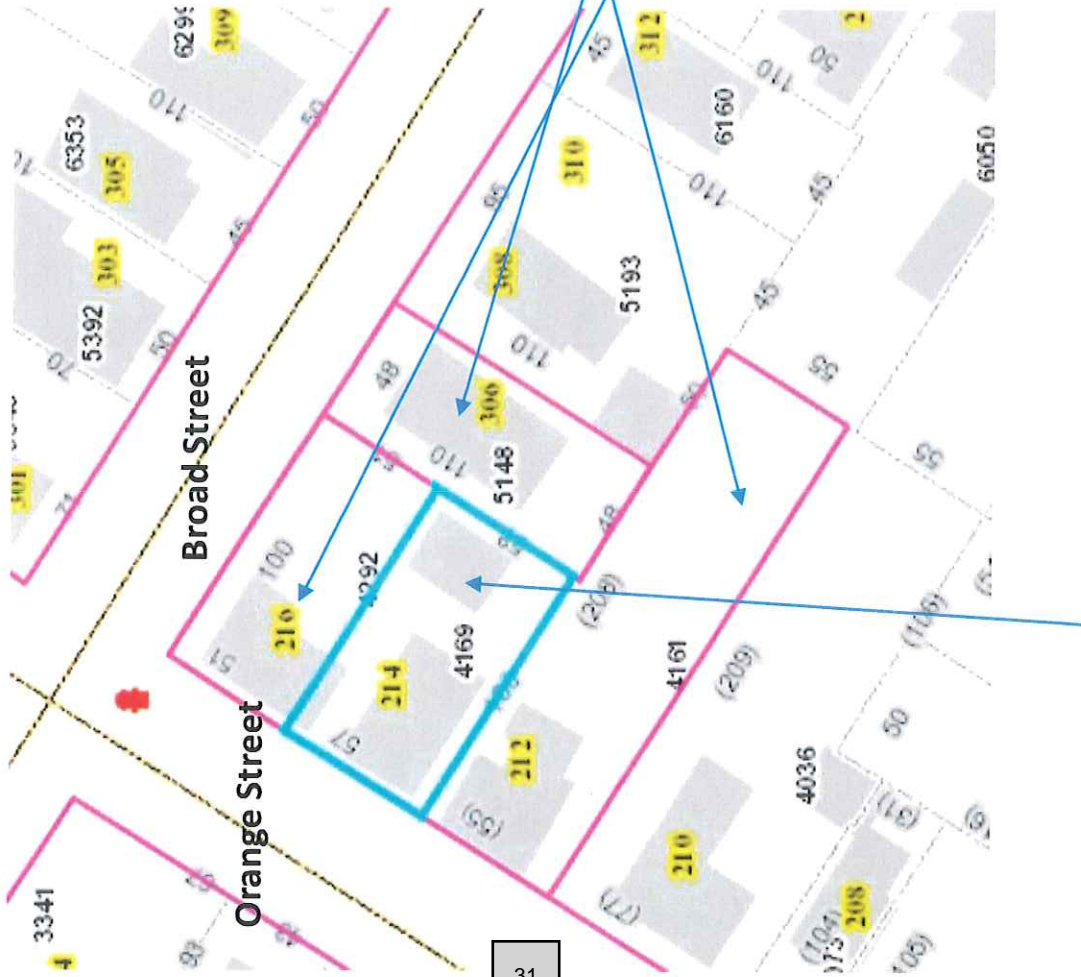

Adjoining Owners

PIN15	OWNER
730617114161000	WILLIS, ADAM DANIEL
730617115148000	OGUS, RICHARD C ETUX MARY H
730617114292000	MAGOWAN, STEVEN F ETUX JOANNE O

Garage to be renovated

The Existing Problematic & Unusable Garage Structure

View of walkway to Garage Structure



Access to existing garage is too narrow for automobile access, hence, changing to golf cart garage. Also, depth of existing garage (to remain) is too short for even a small automobile, rendering the structure obsolete for its original purpose.

View of Garage Structure from Rear Deck



Access to existing garage door on right-side is impossible for access, hence the removal.

View of Garage Structure from Right Rear Side



Right-side of garage in unattractive from rear garden, hence, plan to remove and replace with narrow covered porch and window/door access to structure from the garden.

The Existing Garage Structure Floor Plan

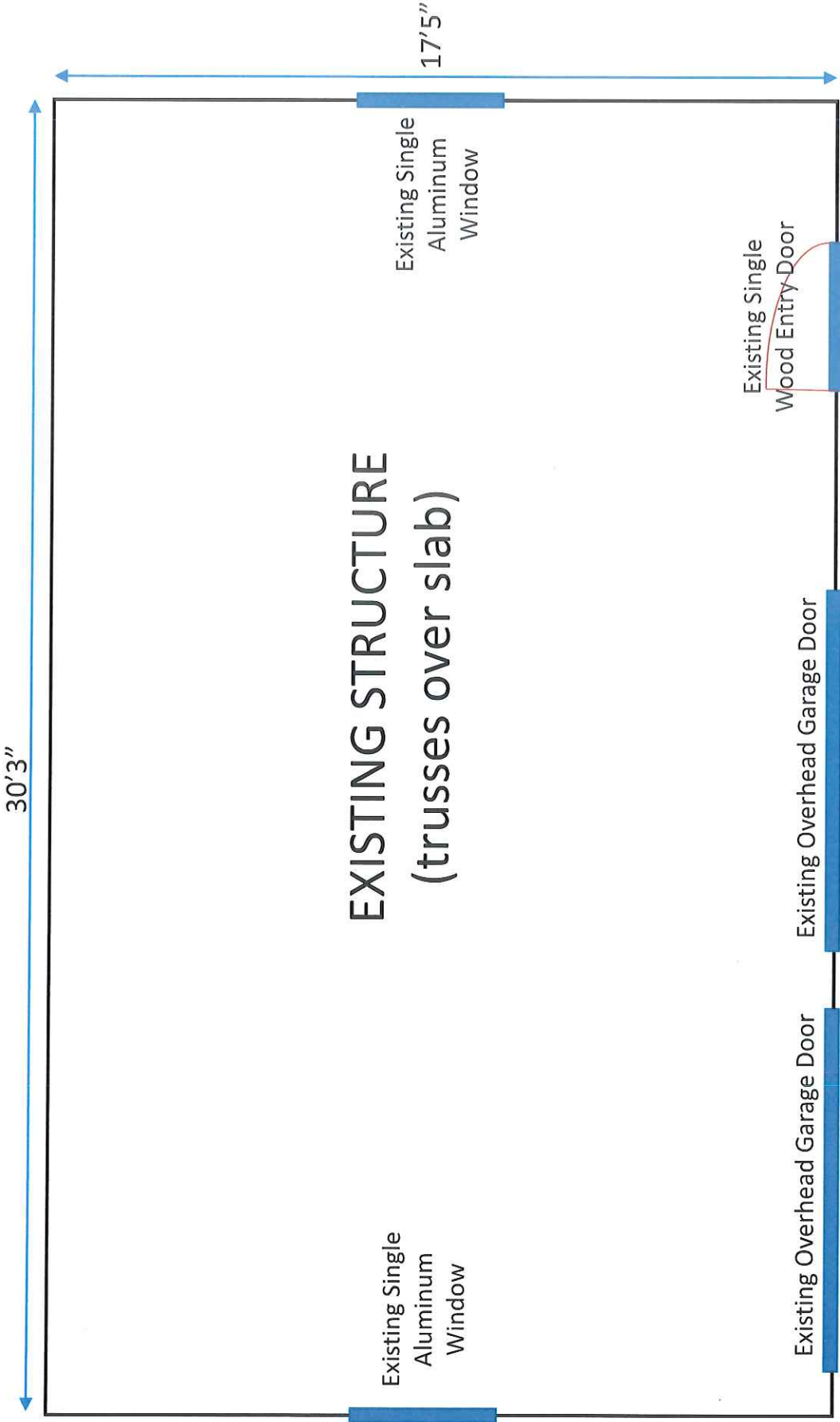

30'3"

Demolition Plan

Existing Single Aluminum Window

Existing Single Aluminum Window

17'5"

Existing Single Wood Entry Door

Existing Overhead Garage Door

Existing Overhead Garage Door

2. Remove exterior side wall, including window

2.

1. Remove exterior front wall, including all doors

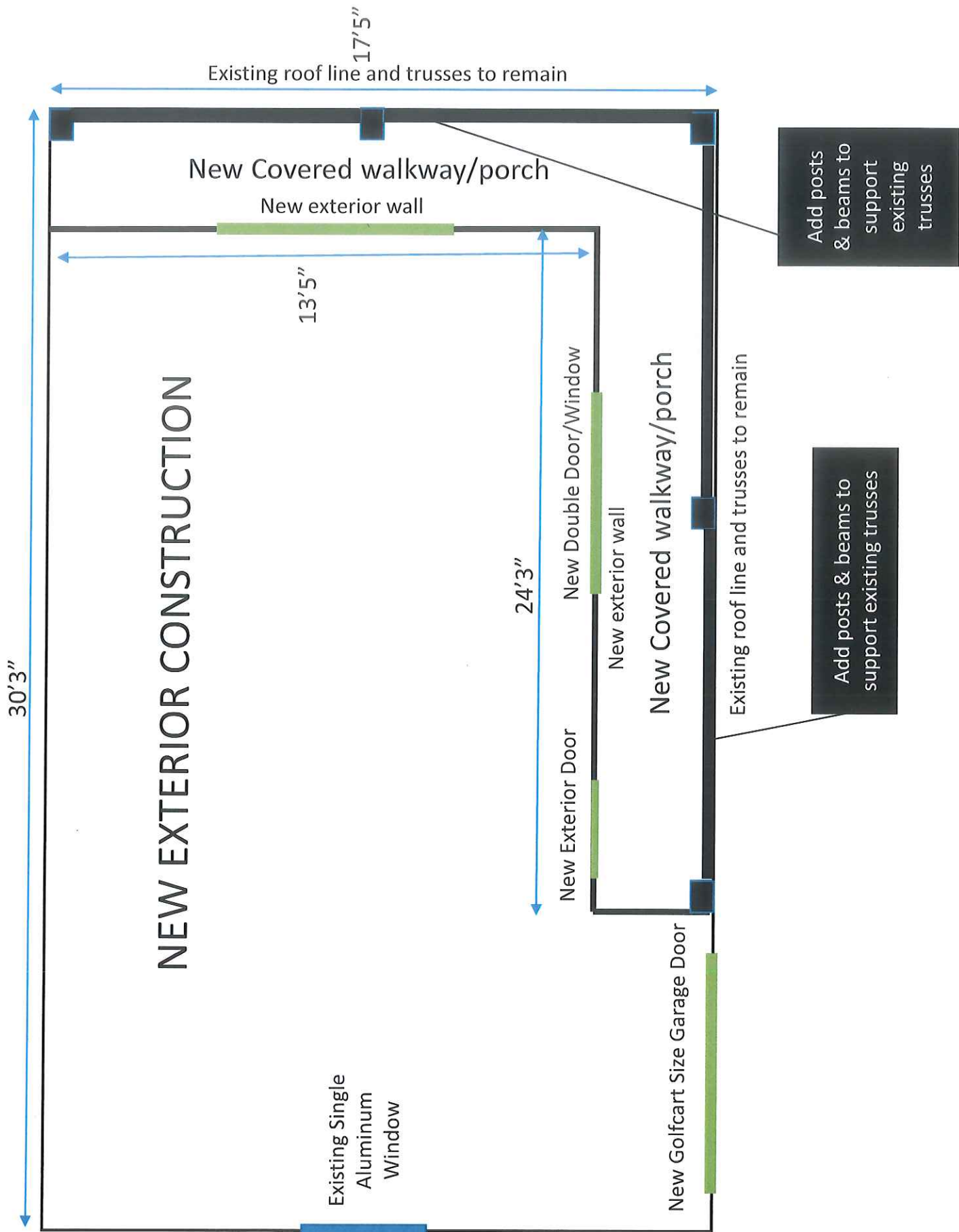

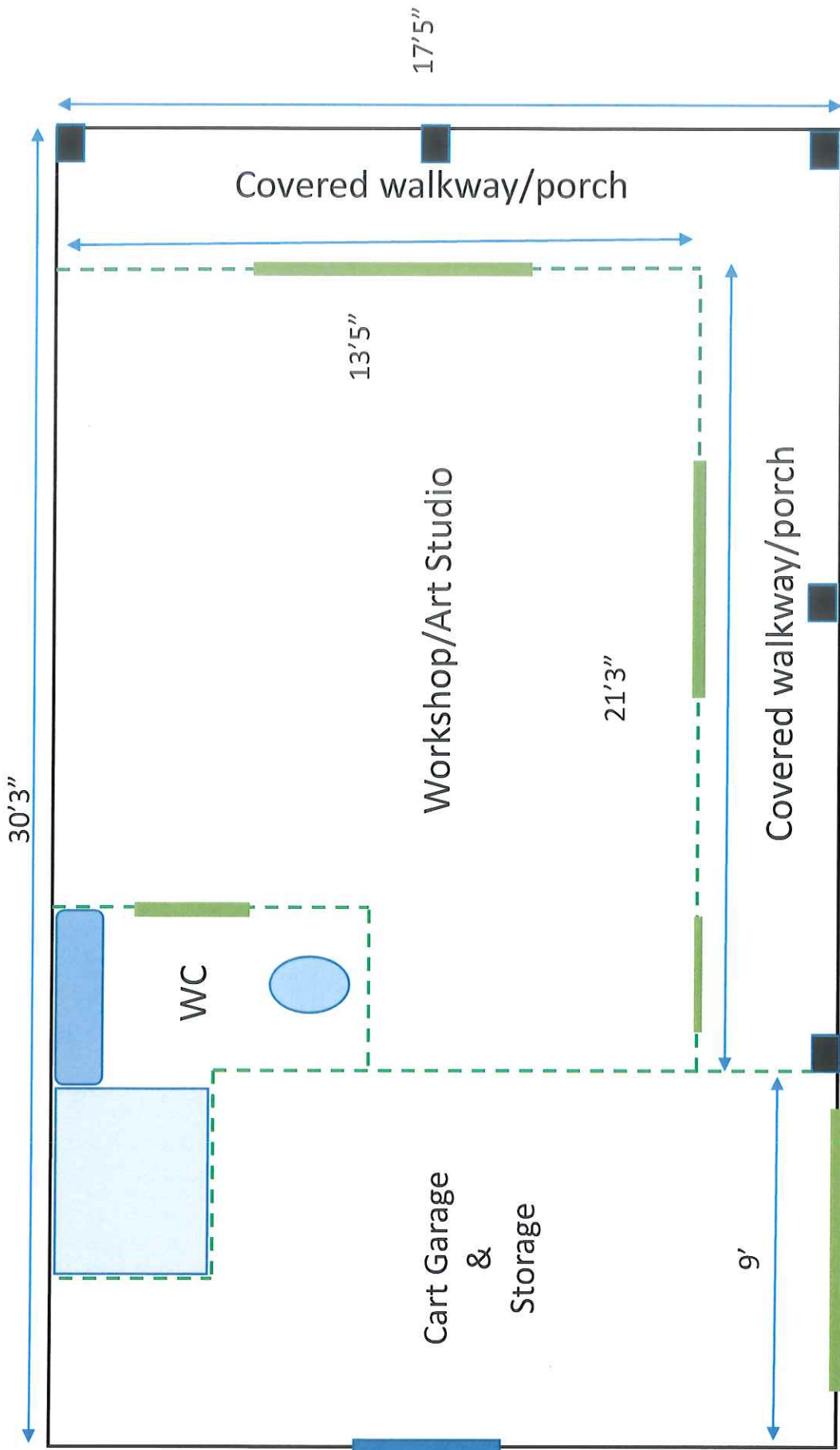

NEW INTERIOR CONSTRUCTION



Town of Beaufort, NC

701 Front St. - P.O. Box 390 - Beaufort, N.C. 28516
252-728-2141 - 252-728-3982 fax - www.beaufortnc.org

**Town of Beaufort Historic Preservation Commission Regular Meeting
6:00 PM Tuesday, December 6, 2022 – 614 Broad Street – Train Depot**

AGENDA CATEGORY: New Business
SUBJECT: Case # 22-33 118 Orange Street – Accessory Structure

BRIEF SUMMARY:

The applicant wishes to add a 285 sq. ft addition to the back of the existing 202 sq. ft. accessory structure with the replacement of the existing roof with a similar 5V galvanize metal material and replacing the siding of the structure with weather resistant and long-lasting cedar shake siding, like that of the Maritime Museum and the Wooden Boat Center.

REQUESTED ACTION:

Conduct Quasi- Judicial Hearing

EXPECTED LENGTH OF PRESENTATION:

15 Minutes

SUBMITTED BY:

Kyle Garner

BUDGET AMENDMENT REQUIRED:

N/A



BHPC STAFF REPORT



To: BHPC Members
From: Kyle Garner, Planning Director
Date: November 21, 2022
Case No. 22-33

Request: To add a 285 sq. ft addition to the back of the existing 202 sq. ft. accessory structure with the replacement of the existing roof with a similar 5V galvanize metal material and replacing the siding of the structure with weather resistant and long-lasting cedar shake siding, like that of the Maritime Museum and the Wooden Boat Center.

Applicant: Sam & Megan Emrich
 2413 Ridge Road
 Raleigh, NC 27612

Property Information:

Owners: Same
Location: 118 Orange Street
PIN#: 730617101688000

Project Information: 1998 - COA was granted for rebuilding an accessory structure in the rear yard (Approx. 12' X 20'). (See 1998 COA)

2003 - A COA was approved to allow crushed brick in the center and brick pavers on the side.

Proposed work:

- See Attachment from Applicant

Material:

- After discussion with the applicant on November 15, 2022, they will be submitting their materials as evidence during the hearing on December 6th as either a PowerPoint presentation or PDF's. The applicant has stated that the windows, doors, and paint will match the existing structure.

Color:

See Attached Description from Applicant.

Attachments:

- Vicinity Map
- List of adjacent property owners used for mailing notifications
- COA application and supporting materials supplied by applicant.
- Photos taken in 2010 of Accessory Structure/Garage

Landscaping Guidelines

8.1.8. New construction and additions should be sited in locations that will not require the removal of mature plantings, if possible.

8.1.13. New tool sheds, swimming pools and other modern yard features should be located in areas not seen from public view.

Roof Guidelines

6.1.3 New roofing materials should be compatible with either the existing or original roofing material. Match the historic material as closely as possible in color, shape, size, and texture. Asphalt or fiberglass-asphalt shingles are acceptable substitutes for standing-seam tin, wood shingles, or metal shingles. Any distinctive patterns of shingles or slates shall be retained and/or replicated exactly. Galvanized standing-seam with a large “agricultural” ridge, usually for ventilation, is not acceptable in the historic district. Instead, use standing seam metal with a crimped edge.

Wood Siding, Trim, and Ornament Guidelines

6.2.1. Preserve and maintain existing original wood siding, trim, ornamentation, and other wood decorative elements.

Window and Door Guidelines

6.4.7. New windows must match original in overall size and opening area and should have three dimensional muntin’s with either true divided lights (TDL) or three-dimensional grilles on both the interior and exterior sides (SDL). Snap-in grilles or grilles between glass are not appropriate for windows visible from public view.

6.4.10. New window and door openings shall not alter the historic character of the building or cause damage to historic materials or other significant architectural features. They must be detailed and sized to be compatible with the existing structure.

Paint and Exterior Colors Guidelines

6.7.1. Repainting a building in the same color, including minor touch-up painting, and the cleaning of existing painted surfaces do not require a COA, nor does re-lettering a painted sign in the same color.

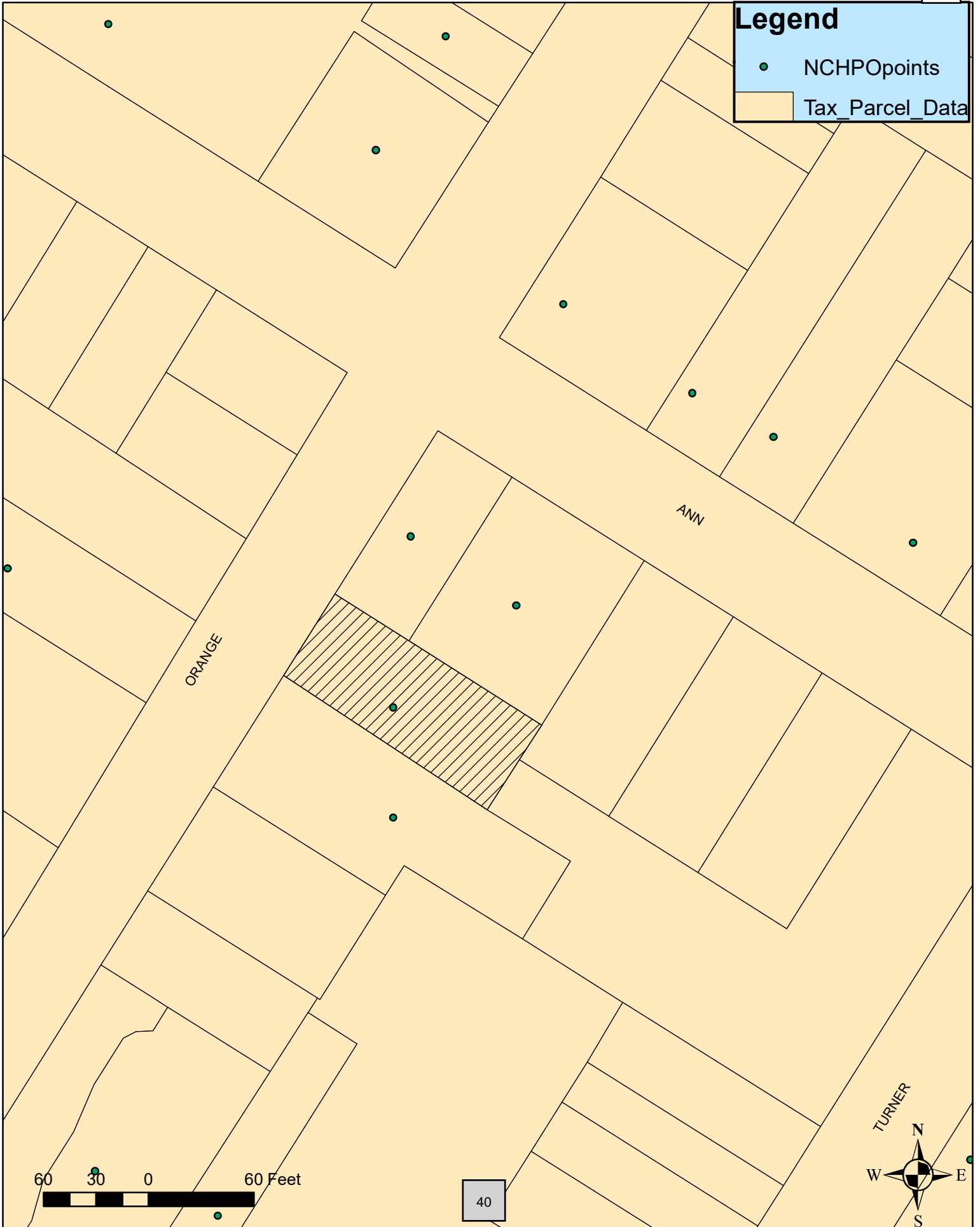

<u>OWNER</u>	<u>MAIL_HOU:</u>	<u>MAIL_ST</u>	<u>MAIL_CITY</u>	<u>MAIL_ST/MAIL_ZI</u>	<u>MAIL_ADD2</u>
DAVIDSON,ARIAIL SCOTT			ASPEN	CO 81612	PO BOX 5141
EMRICH,MEGAN B ETVIR SAMUEL	2413	RIDGE ROAD	RALEIGH	NC 27612	
FIRST BAPTIST CHURCH BEAUFORT	403	ANN STREET	BEAUFORT	NC 28516	
JONES,SUSAN O ETVIR ROSS	1820	PEACHTREE STREET NW	ATLANTA	GA 30309	#1912
MARSHALL,ROBERT ETUX LORENA	2804	ROTHGEB DRIVE	RALEIGH	NC 27609	
MOUNTCASTLE,RICHARD ETUX AMAND	12121	CASTLE RIDGE ROAD	RALEIGH	NC 27614	
STEPHENSON,CATHERINE POTTER	116	ORANGE ST	BEAUFORT	NC 28516	
THE '04 THOMAS O HOLLINSHED TR	100	S RIDGE STREET	SOUTHERN PINES	NC 28387	

CERTIFICATE OF APPROPRIATENESS APPLICATION FOR PROJECTS WITHIN THE BEAUFORT HISTORIC DISTRICT



Instructions:

Please complete the application below and include all attachments as noted on page 2 of this application along with a **\$250.00 application fee** and return to the Beaufort Town Hall; 701 Front Street or P.O. Box 390, Beaufort, N.C. 28516. Incomplete applications will not be processed and **will be** returned to the applicant. Please contact Town Hall at 252-728-2142 if there are any questions.

APPLICANT/OWNER INFORMATION

Please print!

Applicant Name: Samuel and Megan Emrich

Applicant Address: 2413 Ridge Rd. Raleigh, NC 27612

Business Phone: 919-622-1991 Email/Cell: megemrich@icloud.com

Property Owner Name: Samuel and Megan Emrich

Address of Property: 118 Orange St. Beaufort

Phone Number: 919-260-3524 Email/Cell: sremrich@gmail.com

PROJECT INFORMATION

Detailed description of the Proposed Project (please attach additional pages if necessary):

The purpose of this project is to restore the existing back structure at 118 Orange Street - DW and Minnie Morton house. The restoration is necessary due to disrepair of the existing siding and leaking roof. In addition to the restoration, we are planning to add square footage off the back of the structure. Please see booklet and PDF for additional detail.

Estimated Cost of Project: \$80-90,000

Year House Built: Back Structure ~1996

[Signature]
Applicant Signature

11/10/2022
Date

Property Owner Signature (if different than above)

Date

An application fee of \$250.00, either in cash, money order, or check made payable to the "Town of Beaufort" must accompany this application (a credit or debit card payment can be made in person at Town Hall). The complete application, payment, and supporting material must be received by Town Staff by the posted submittal dates noted on the Historic Preservation's calendar found on the Town's website at www.beaufortnc.org. The Commission meets regularly on the first Tuesday of the month unless it is a holiday.

OFFICE USE ONLY

Received by: _____

Reviewed for Completeness: _____

Date: _____

Date Deemed Completed and Accepted: _____

BACK BUILDING 118 ORANGE ST



PREPARED FOR BEAUFORT TOWN
COMMISSION

09 NOVEMBER 2022

LOCATION AND NEIGHBORS

Concealed from the neighbors and tucked away from the street this back structure is very private. Below are a list of adjacent property owners:

Marshall, Robert & Lorena

Physical Address: 119 ORANGE ST, BEAUFORT, NC 28516
Mailing Address: 2804 ROTHGEB DRIVE
RALEIGH NC 27609

Stephenson, Catherine Potter 116 ORANGE ST, BEAUFORT, NC 28516

Mountcastle, Richard & Amand

Physical Address: 300 ANN ST, BEAUFORT, NC 28516
Mailing Address: 12121 CASTLE RIDGE ROAD, RALEIGH NC 27614

Thomas O Hollinshed

Physical Address: 306 ANN ST, BEAUFORT, NC 28516
Mailing Address: 100 S RIDGE STREET
SOUTHERN PINES NC 28387

Davison, Ariail Scott

Physical Address: 308 ANN ST, BEAUFORT, NC 28516
Mailing Address: PO BOX 5141, ASPEN CO 81612

First Baptist Church Beaufort

Physical Address: 0 ANN ST, BEAUFORT, NC 28516
Mailing Address: 403 ANN STREET, BEAUFORT NC 28516

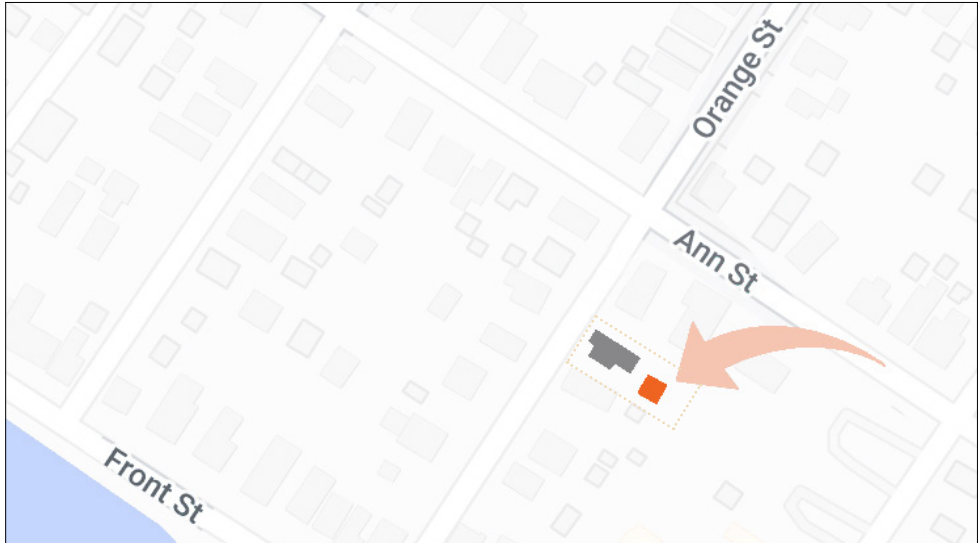

PLAN

The intent of this project is to restore and update the current back house that was added to the property by the previous owners, Al and Ann Goellner. Replacing the original "side gabled garage and shed circa 1900 (per 1997 historical survey)," the current back house was built to serve as an art studio for Al, a beloved local artist, and aptly named the Sycamore Studio paying homage to the beautiful Sycamore tree on the property. We plan to preserve some of this special history while restoring and updating the structure; and maintaining its modest presence on the property so as not to take away from the attraction of the main house - the DW and Minnie Morton House. The existing back house structure currently has rough sawn cypress board and batten that is cracked, rotting and in disrepair after only 30 years of being in use. We would like to side the current structure with a modest addition on the back of the structure, replacing the existing roof with a similar 5V galvanize metal material, and replacing the siding of the structure with weather resistant and long lasting cedar shake siding, like that of the Maritime Museum and the Wooden Boat Center.

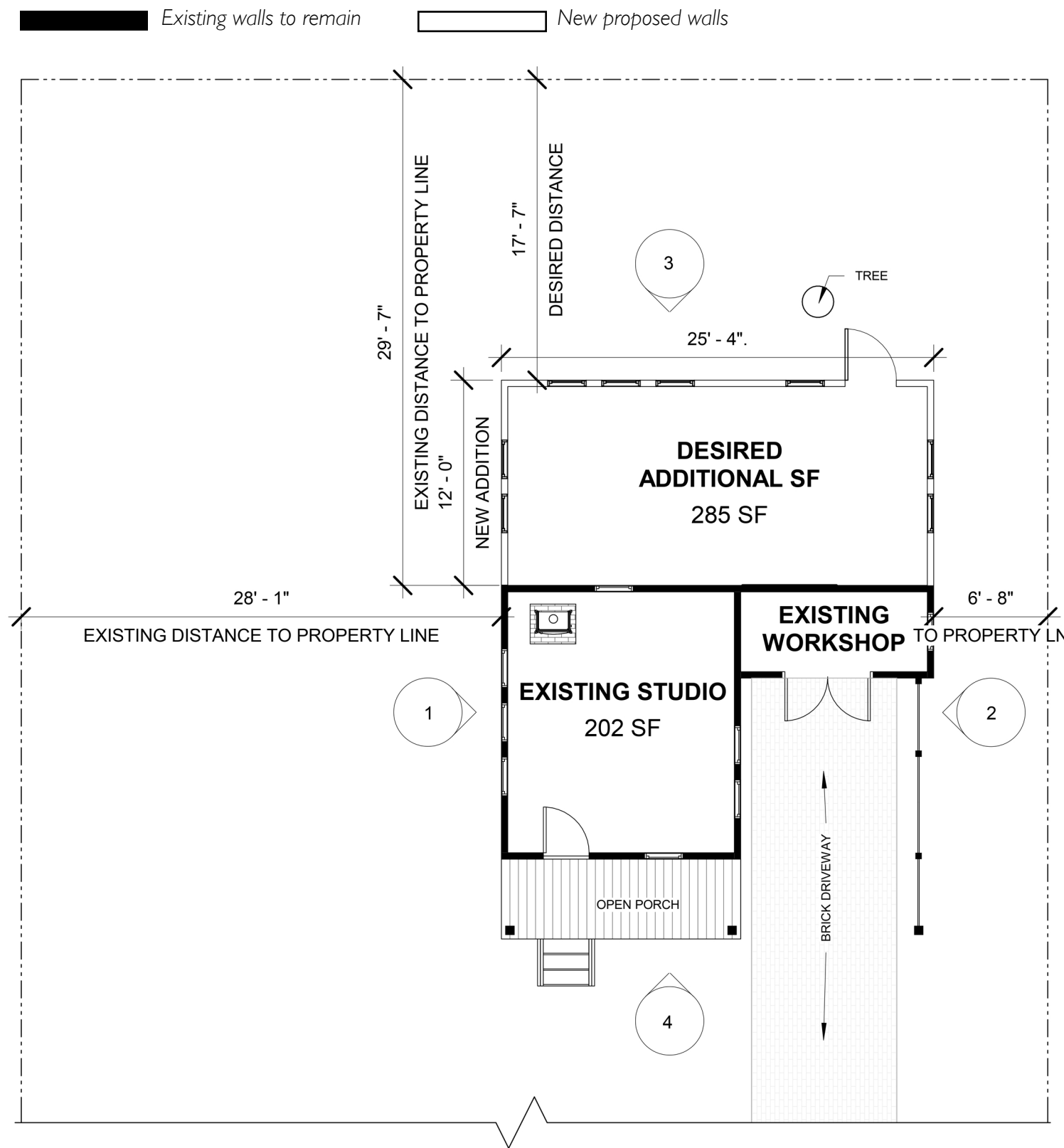

1 DESIRED PLAN
1/8" = 1'-0"

DEMOLITION

Minimal demolition is scheduled for this project. The majority of demolition will be the done to the roof (see attached drawing). Additional demo will involve the removal of all siding. Exterior framing however will remain as is. Windows will be removed and replaced with a similar style and lastly the deck will be re-built using IPE hardwood decking.

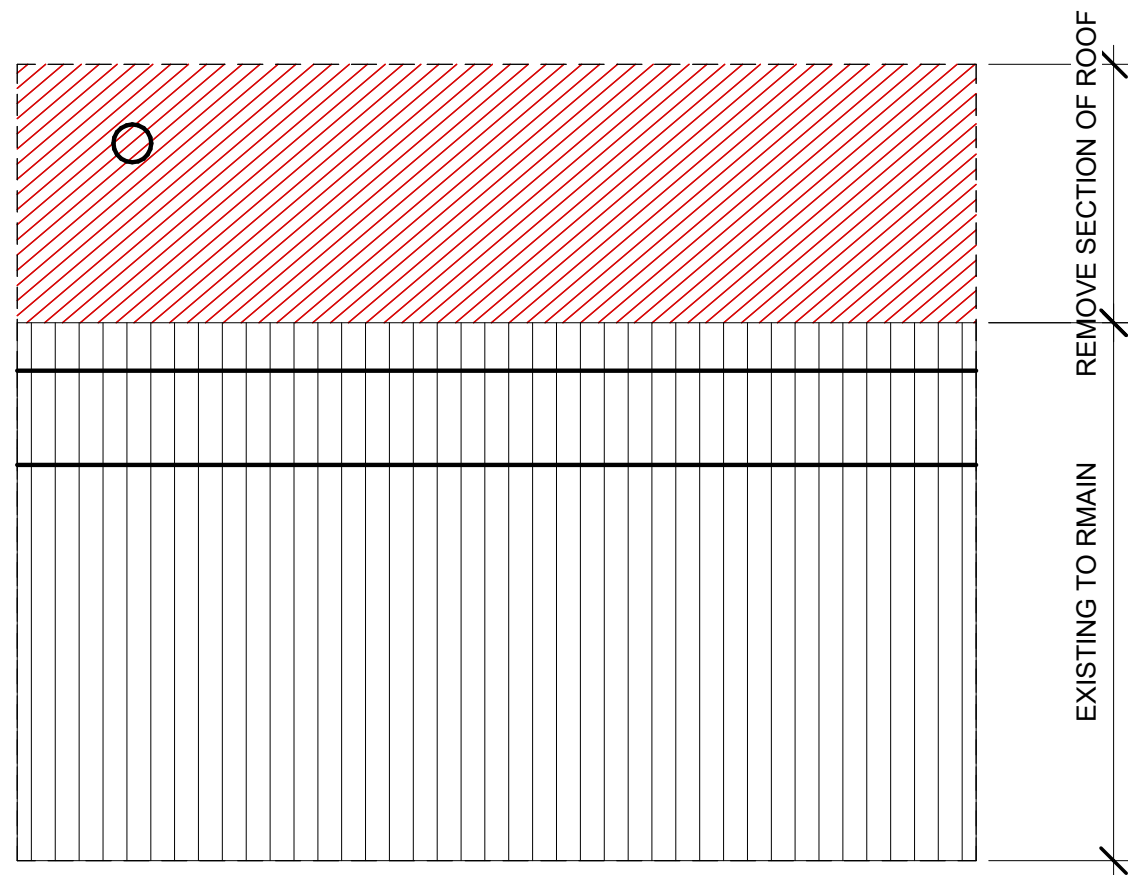

① ROOF DEMO PLAN
3/16" = 1'-0"

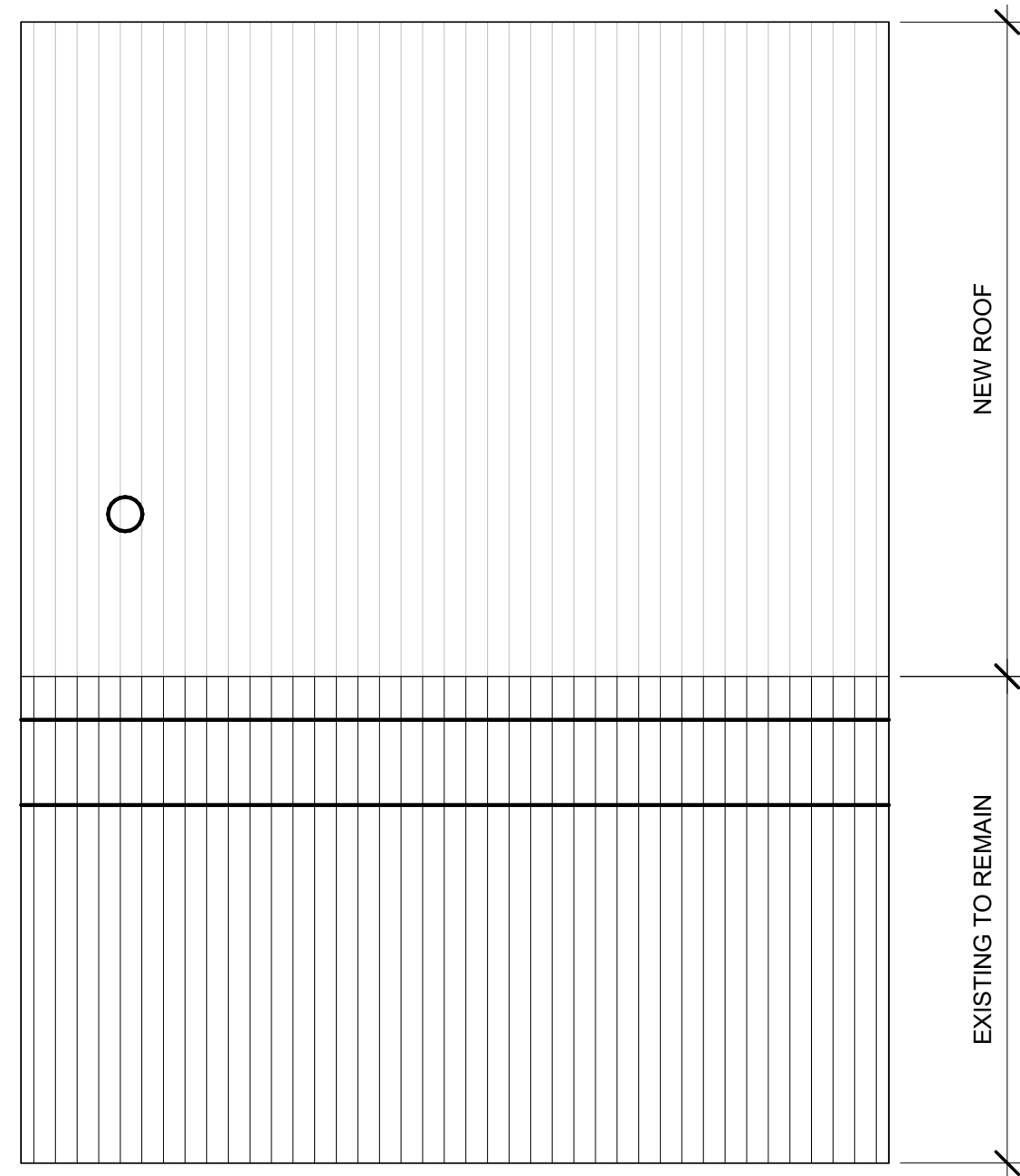

② ROOF PLAN
3/16" = 1'-0"

MATERIALS

We are choosing long lasting materials to honor the historical district and blend with similar materials already seen throughout the district, as well as complement the main house without drawing attention to the back structure.

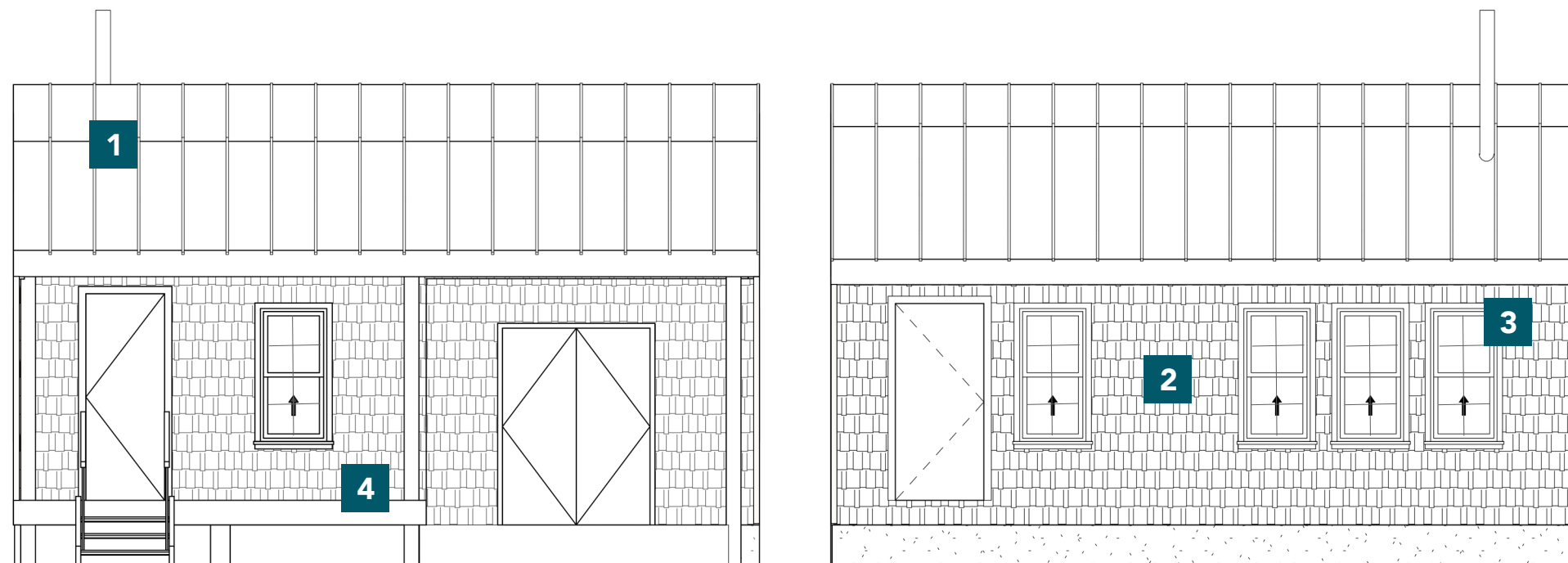

4 FRONT ELEVATION
3/16" = 1'-0"

3 BACK ELEVATION
3/16" = 1'-0"

SPECIFICATION OPTIONS

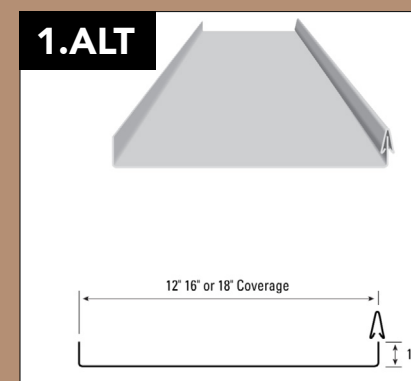
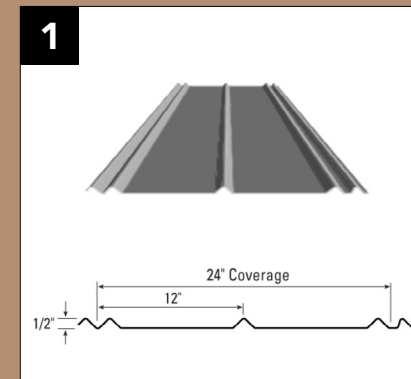

- 1. Galvanized Steel 5V - to match existing. Color: Metal ([link](#))
- 1.ALT Standing Seam Metal -Mini Batten 1" Color: Metal ([link](#))
- 2. Western Red Cedar Shake ([link](#)) Color: Weathered Gray
- 2.ALT Cypress Board & Batten ([link](#)) Color: Weathered Gray

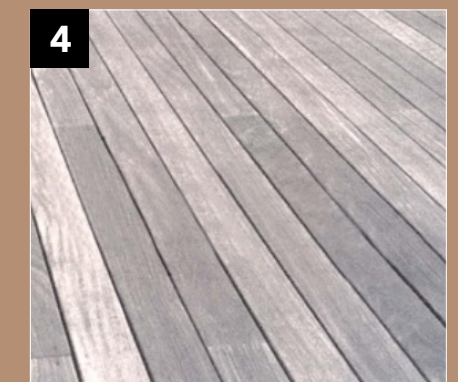
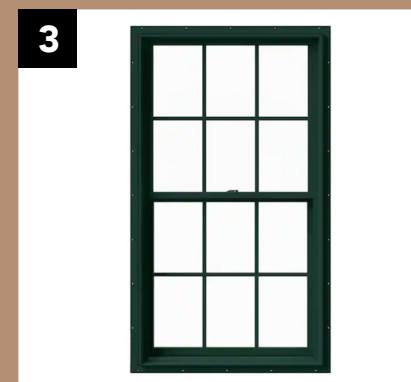

- 3. Clad Wood Double Hung Window. Color: Green ([link](#))
- 4. IPE Hardwood Decking. Color: Naturally Weathered ([link](#))

ROOF 5V DISTRICT EXAMPLES



Main House - 118 Orange Street



115 Broad Street



108 Moore Street



305 Moore Street

STANDING SEAM & SIDING

DISTRICT EXAMPLES



119 Orange Street



122 Ann Street



315 Front Street - Maritime Museum



326 Front Street - Harvey W. Smith Watercraft Center

FINISHES

We are choosing comparable finishes to the original structure, that maintain the subtle and unobtrusive look to allow the main house to remain the focal point of the property.

PALETTE

Benjamin Moore Black Forest Green for door accent color [\(link\)](#)

Long Lasting IPE Wood for deck, naturally weathered

Cabot bleaching stain for siding & trim [\(link\)](#)

Natural Metal Roof

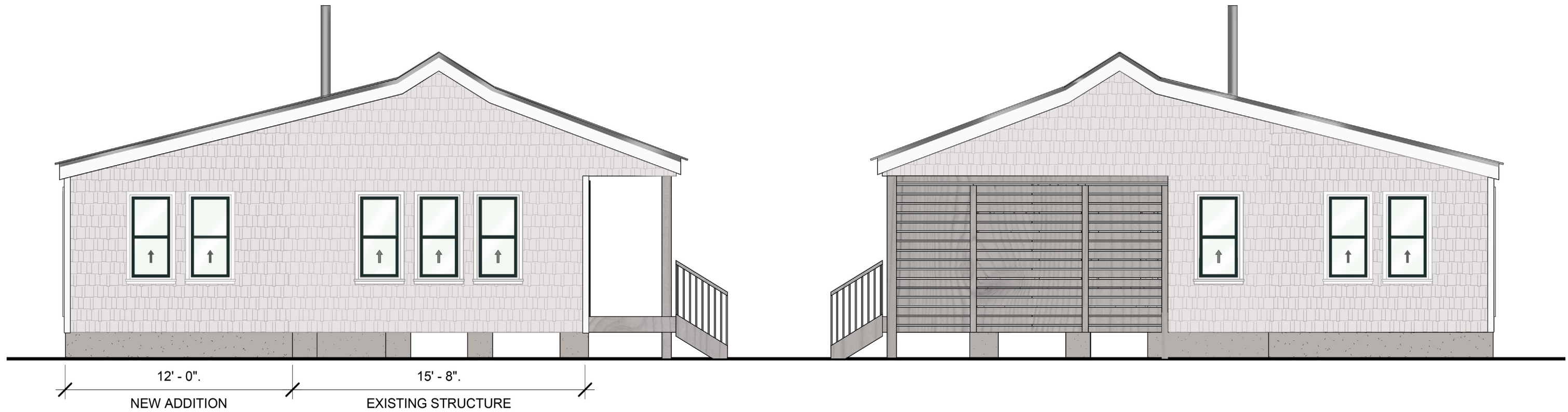
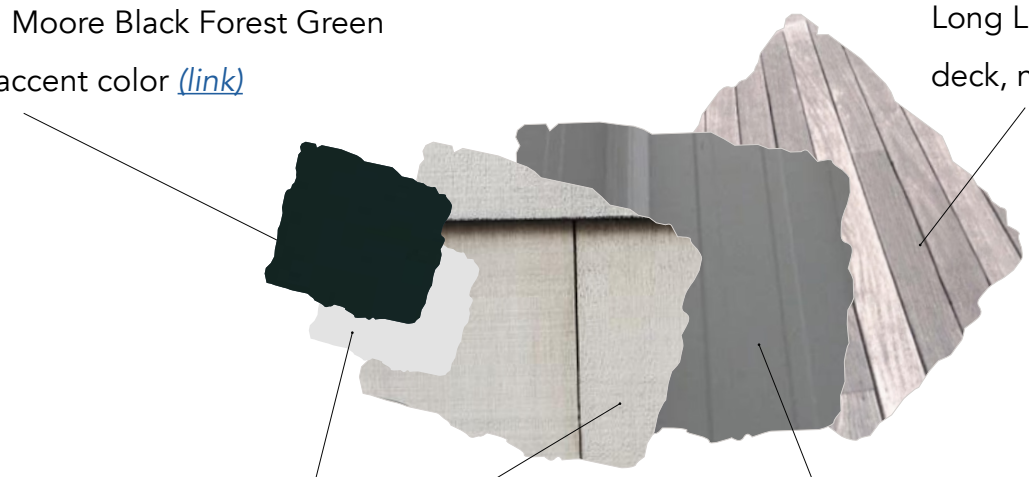

1 NORTH EAST ELEVATION
3/16" = 1'-0"

2 SOUTHWEST ELEVATION
3/16" = 1'-0"

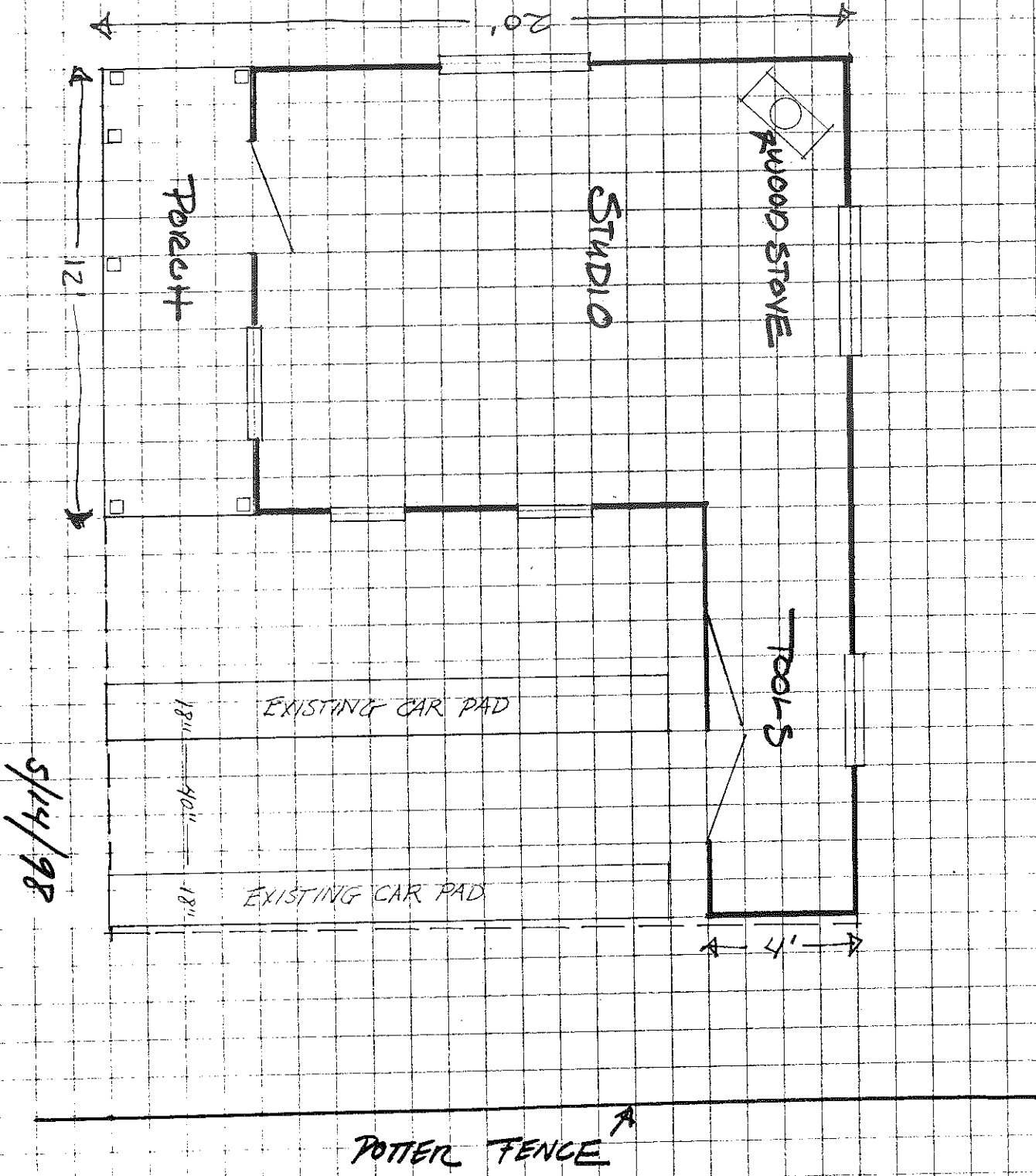

86/14/98

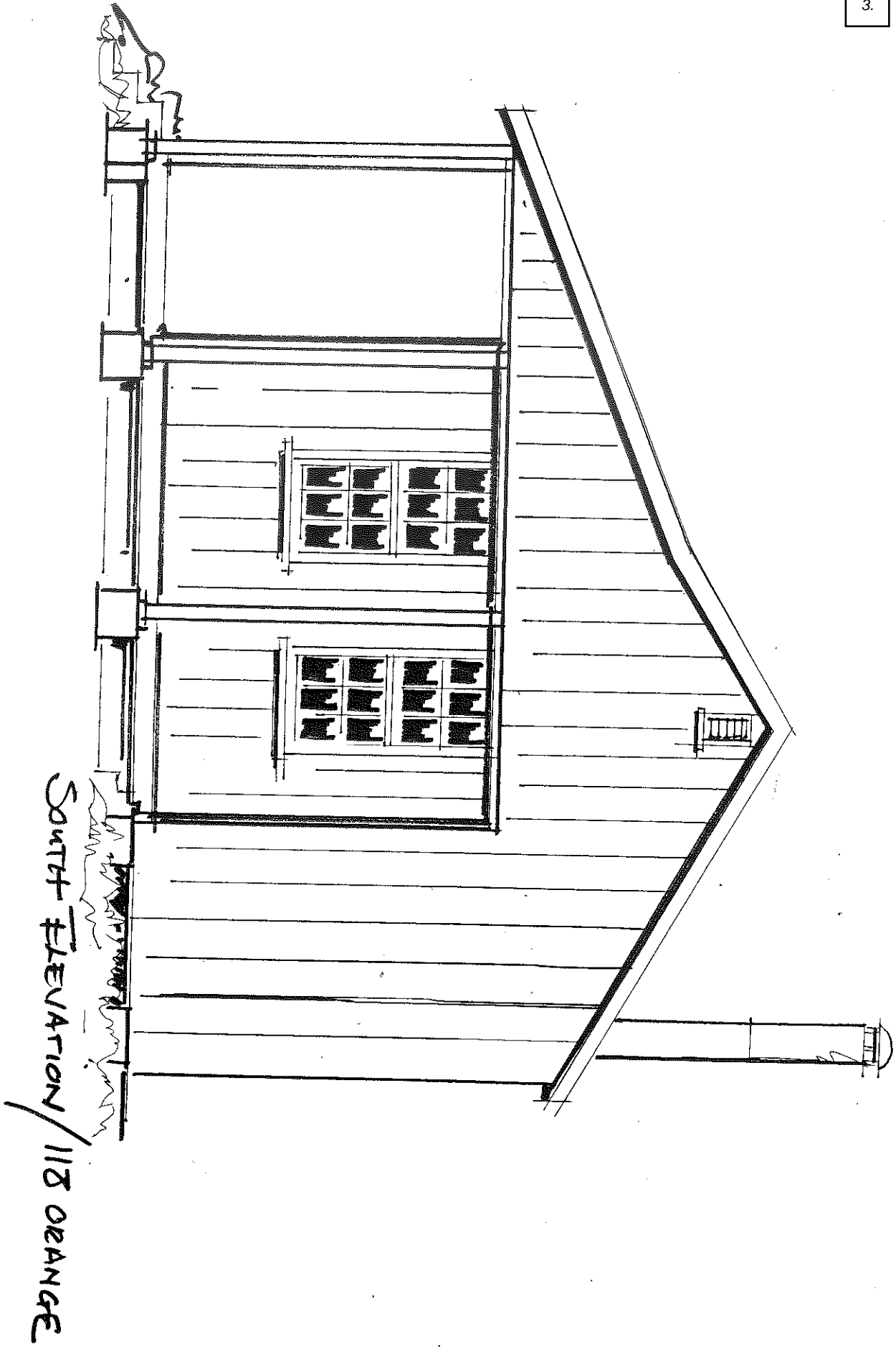

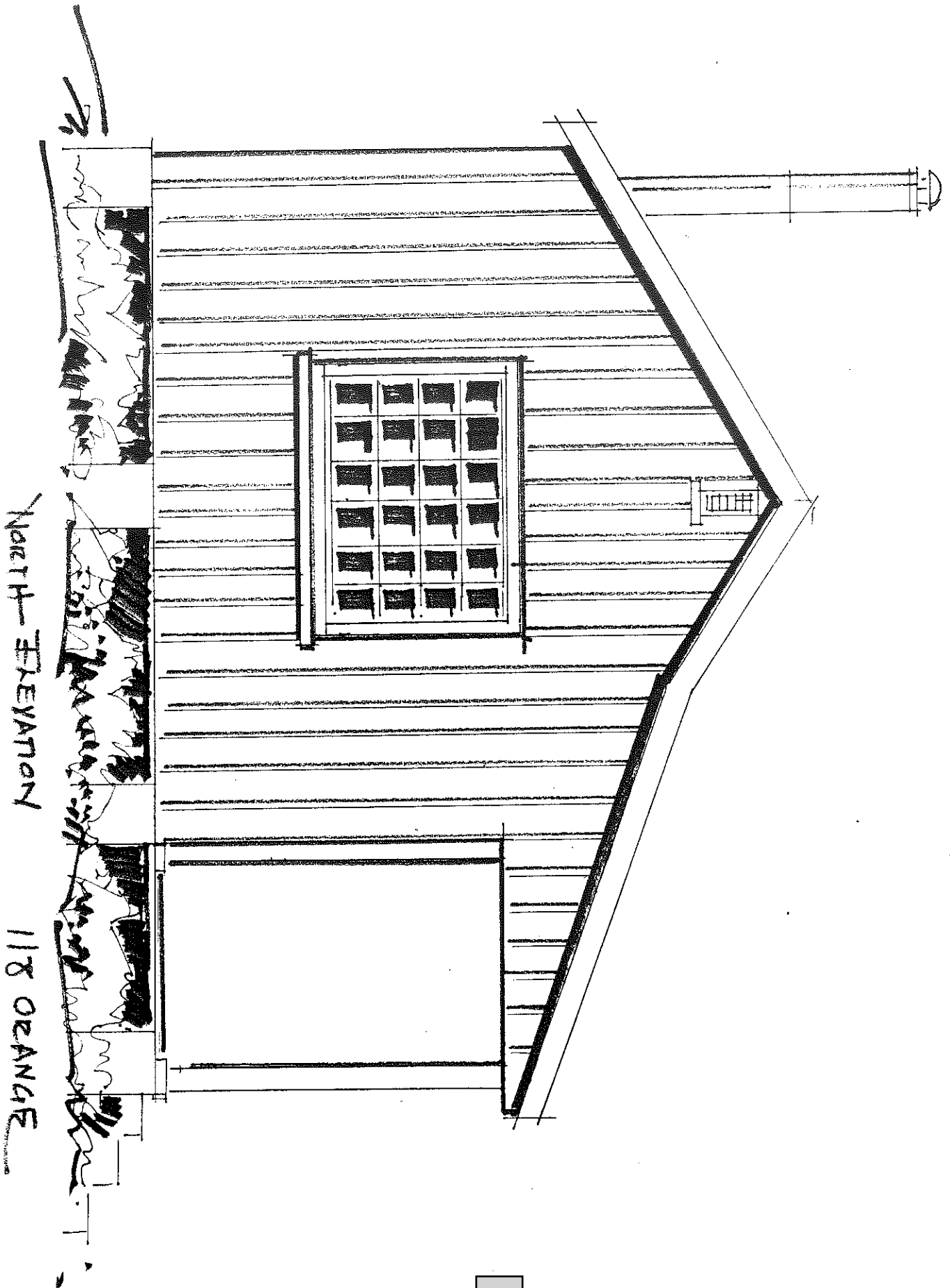

WEST ELEVATION 118. ORANGE

OPEN CAR
PARK

