



## **Town of Beaufort, NC**

701 Front St. - P.O. Box 390 - Beaufort, N.C. 28516  
252-728-2141 - 252-728-3982 fax - www.beaufortnc.org

### **Town of Beaufort Historic Preservation Regular Meeting 6:00 PM Tuesday, February 07, 2023 - Train Depot, 614 Broad Street, Beaufort, NC 28516 Monthly Meeting**

---

#### **Call to Order**

#### **Roll Call**

#### **Agenda Approval**

#### **Minutes Approval**

- [1.](#) HPC Draft Minutes 1.3.23

#### **Election of Officers**

#### **Administration of Oaths**

#### **Items of Consent**

- [1.](#) Approval of the Orders for 305 Moore Street, 510 Front Street & 615 Ann Street–  
Certificates of Appropriateness

#### **Old Business**

- [1.](#) Case # 22-22 211 Broad Street – Raising Existing Structure with New Steps and Chimney  
work

#### **New Business**

- [1.](#) Case # 22-35 211 Orange Street – Driveway, Landscaping & Landscape Lighting
- [2.](#) Case # 22-34 201 Front Street – Fence
- [3.](#) Case # 22-16 121 Turner Street – Signage
- [4.](#) Case # 23-01 521 Front Street - Signage
- [5.](#) Case # 23-02 300 Front Street Unit 3 - New Sign

#### **Commission / Board Comments**

#### **Staff Comments**

**Adjourn**



**Town of Beaufort, NC**  
701 Front St. - P.O. Box 390 - Beaufort, N.C. 28516  
252-728-2141 - 252-728-3982 fax - www.beaufortnc.org

**Town of Beaufort Historic Preservation Regular Meeting**  
**6:00 PM Tuesday, January 3, 2023 - Train Depot, 614 Broad Street, Beaufort, NC 28516**  
**Minutes**

---

**Call to Order**

Chair McCune called the January 3, 2023 Beaufort Historic Preservation Commission regular meeting to order at 6:00 pm.

**Administration of Oaths**

Chair McCune read the quasi-judicial statement and Secretary Anderson administered the Oath to Kyle Garner.

**Roll Call**

Members Present: Chair McCune, Bradley Cummins, Ian Huckabee, Tammy Hunsucker, and John Stephens

Members Absent: Vice-Chair Flowers, Bradley Hedrick

A quorum was declared with five members present.

Staff Present: Kyle Garner, Town Attorney Arey Grady, and Laurel Anderson

**Agenda Approval**

Chair McCune noted that Case #22-35 would be removed from the Agenda and moved to the February Agenda due to illness.

*Member Cummins made the motion to approve the Agenda as updated to remove Case #22-35 and adding Front St to the Case #23-37 description. Member Stephens made the second and Chair McCune took a vote that was unanimously approved.*

*Voting yea: Chair McCune, Bradley Cummins, Ian Huckabee, Tammy Hunsucker, and John Stephens*

**Minutes Approval**

- 1. HPC Draft Minutes for 12.6.22

*Member Huckabee made the motion to approve the Minutes and Member Stephens made the second. Chair McCune took a vote that was unanimously approved.*

*Voting yea: Chair McCune, Bradley Cummins, Ian Huckabee, Tammy Hunsucker, and John Stephens*

## Items of Consent

*Member Hunsucker made the motion to approve the Orders for Case #22-30 400 Front St, Case # 22-31 214 Orange St, and Case #22-33 118 Orange St, and Member Huckabee made the second. Chair McCune took a vote that was unanimously approved.*

*Voting yea: Chair McCune, Bradley Cummins, Ian Huckabee, Tammy Hunsucker, and John Stephens*

## New Business

### 1. Case #22-32; 615 Ann Street – Landscaping

Chair McCune introduced Case #22-32 and Secretary Anderson administered the Oath to the applicant, Becky Oxholm. Mr. Garner explained that this request involves installation of a landscaping retaining wall adjacent to the driveway.

Ms. Oxholm explained that runoff from the roof washes soil into her driveway and requested 8” edging along the driveway, and the narrow edge of the bricks would form the top of the edging.

*Hearing no further questions Chair McCune asked for a motion for a Finding of Fact for Case #22-32 and Member Stephens made the following motion: Having reviewed the record and having considered all evidence submitted and oral testimony for case #22-32, move that the Commission conclude that the pending application meets the following design standards under the Design Guidelines for the Beaufort Historic District and Landmarks: Signage Guidelines 8.1.5 and 8.2.4.*

*Member Cummins made the second and Chair McCune took a vote.*

*Voting yea: Chair McCune, Bradley Cummins, Ian Huckabee, Tammy Hunsucker, and John Stephens*

Chair McCune then asked for a motion to approve a Certificate of Appropriateness (COA) for Case #22-32.

*Member Cummins made a motion to approve the Certificate of Appropriateness based on the following: That the proposed project is not incongruous with the special character of the historic district as a whole and that a Certificate of Appropriateness for case #22-32 be issued for the proposed work.*

*Member Huckabee made the second. Chair McCune took a vote that was unanimously approved.*

*Voting yea: Chair McCune, Bradley Cummins, Ian Huckabee, Tammy Hunsucker, and John Stephens*

Chair McCune then declared Case #22-32 closed.

### 2. Case #22-34; 201 Front Street – Fence

Chair McCune introduced Case #22-34 and asked if the applicant would be presenting. As the applicant or a representative was not at the meeting she asked for a motion to table the application until the next meeting.

*Member Huckabee made the motion to table the application and Member Stephens made the second. Chair McCune took a vote that was unanimously approved.*

*Voting yea: Chair McCune, Bradley Cummins, Ian Huckabee, Tammy Hunsucker, and John Stephens*

### 3. Case #22-36; 305 Moore Street – Accessory Structure

Chair McCune introduced Case #22-36 and Secretary Anderson administered the Oath to the applicant's contractor, Archie Davis. Mr. Garner explained that the applicant wanted to delete the previously approved garage door and replace the door with two windows and a walk-in door for the approved rear accessory structure.

There was a short discussion about the doors and Chair McCune noted that the building could not easily be seen from the street.

*Hearing no further questions Chair McCune asked for a motion for a Finding of Fact for Case #22-36 and Member Stephens made the following motion: Having reviewed the record and having considered all evidence submitted and oral testimony for case #22-36, move that the Commission conclude that the pending application meets the following design standards under the Design Guidelines for the Beaufort Historic District and Landmarks: Landscaping 8.1.13, Window and Door Guidelines 6.4.7, 6.4.10.*

*Member Cummins made the second. Chair McCune took a vote that was unanimously approved.*

*Voting yea: Chair McCune, Bradley Cummins, Ian Huckabee, Tammy Hunsucker, and John Stephens*

Chair McCune then asked for a motion for a Certificate of Appropriateness for Case #22-36.

*Member Huckabee made a motion to approve the Certificate of Appropriateness based on the following: That the proposed project is not incongruous with the special character of the historic district as a whole and that a Certificate of Appropriateness for case #22-36 be issued for the proposed work.*

*Member Cummins made the second. Chair McCune took a vote that was unanimously approved.*

*Voting yea: Chair McCune, Bradley Cummins, Ian Huckabee, Tammy Hunsucker, and John Stephens*

Chair McCune then declared Case #22-36 closed.

### 4. Case #22-37; 510 Front Street – Doors, Windows & Signage

Chair McCune introduced Case #22-37 and Secretary Anderson administered the Oath to the applicant, Jeff Adams. Mr. Garner explained that the applicant requested to install a 14.6 sq. ft. sign made of high-density urethane, install a new door at Front Street entrance to units above and replace four (4) windows on rear (waterside) that open. The total signage allowed for the Front Street side is 200 sq. feet. In 2021 a COA was granted for a new 16 sq. ft sign facing Front (Beaudega), in 2017 a COA was granted for a new 16 sq. ft. sign facing Front (Black Sheep), in 2017 a COA was granted to install 3 retractable awnings on upper units, in 2010 a COA was granted for a 16 sq. ft. sign (Queen Annes Revenge). Other COAs have been granted for this building going back to 2003 and mostly for signage for businesses and for the screening fence on the east side of the structure next to the Boardwalk.

Member Hunsucker asked which colors were acceptable in the guidelines, and Mr. Garner explained that basic colors were usually approved. Mr. Adams explained that the existing windows are fiberglass and the trim will be the same. He showed the Board a color chip of the requested green paint. Mr. Adams stated that there are 56 windows and he is requesting to change four windows. Chair McCune pointed out that under the current guidelines grilles between glass are not usually approved, but as the building is not historic and all of the existing windows have grilles between glass, uniformity for all windows would be preferable.

*Hearing no further questions Chair McCune asked for a motion for a Finding of Fact for Case #22-37 and Member Stephens made the following motion: Having reviewed the record and having considered all evidence submitted and oral testimony for case #22-37, move that the Commission conclude that the pending application meets the following design standards under the Design Guidelines for the Beaufort Historic District and Landmarks: Signage 8.6.1, 8.6.2, 8.6.3, 8.6.5, Window and Door Guidelines 6.4.3, 6.4.7, 6.4.10, with the understanding that the trim on the new door to be installed will match the existing door, and the new door will match the existing door.*

*Member Cummins made the second. Chair McCune took a vote that was unanimously approved.*

*Voting yea: Chair McCune, Bradley Cummins, Ian Huckabee, Tammy Hunsucker, and John Stephens*

Chair McCune then asked for a motion for a Certificate of Appropriateness for Case #22-37.

*Member Huckabee made a motion to approve the Certificate of Appropriateness based on the following: That the proposed project is not incongruous with the special character of the historic district as a whole and that a Certificate of Appropriateness for case #22-37 be issued for the proposed work, with the following conditions: that the trim on the new door to be installed will match the existing door, and the new door will match the existing door.*

*Member Stephens made the second. Chair McCune took a vote that was unanimously approved.*

*Voting yea: Chair McCune, Bradley Cummins, Ian Huckabee, Tammy Hunsucker, and John Stephens*

Chair McCune then declared Case #22-37 closed.

### **Commission / Board Comments**

- a. Member Hunsucker asked when the updated guidelines would be coming before the commission.
- b. Chair McCune asked if newer members could review the proposed guidelines.

### **Staff Comments**

- a. Mr. Garner stated that Mr. John Wood of the State Preservation Office would return in March or April 2023 for a workshop with the HPC covering proposed updates to the Historic Standards, and there would be a resiliency component to be adopted into the revised standards and the Town of Beaufort would be the first historic district to incorporate the resiliency standards.
- b. He explained that paint colors in the historic district are approved on a case-by-case basis as paint color names change frequently.
- c. Chair McCune noted that Swansboro had signs delineating the historic district and requested the Board look into signs for Beaufort's historic district, and Mr. Garner recommended requesting funding for the next fiscal year from the Board of Commissioners for the signs.
- d. Mr. Garner reminded the Board about the potential cemetery workshop in the spring, and proposed a public information meeting to inform, engage, and educate the community regarding historic preservation.

**Adjourn**

*Member Huckabee made the motion to adjourn and Member Stephens made the second. Chair McCune took a vote that was unanimously approved.*

*Voting yea: Chair McCune, Bradley Cummins, Bradley Hedrick, Tammy Hunsucker, and John Stephens*

Chair McCune declared the January 3, 2023 meeting adjourned.

---

Chair, Joyce McCune

---

Board Secretary, Laurel Anderson



**Town of Beaufort, NC**

701 Front St. - P.O. Box 390 - Beaufort, N.C. 28516  
252-728-2141 - 252-728-3982 fax - www.beaufortnc.org

**Town of Beaufort Historic Preservation Commission  
6:00 P.M. February 7, 2023 – 614 Broad Street – Train Depot**

---

**AGENDA CATEGORY:** Consent  
**SUBJECT:** Approval of the Orders for 305 Moore Street, 510 Front Street & 615 Ann Street– Certificates of Appropriateness

**BRIEF SUMMARY:**

As part of the new General Statutes (160D), prior to Evidentiary Hearing Orders being signed and sent to the applicant/property owners, the Board in which conducted the hearing is to review the order for accuracy.

The staff has consulted with the Town Attorney and now asks that the Historic Commission Members review the orders for such accuracy and be prepared to make a motion to recommend approval of the Order or to approve with Commission recommended changes.

**REQUESTED ACTION:**

Review the order for such accuracy and be prepared to make a motion to recommend approval of the Order or to approve with Commission recommend changes

**EXPECTED LENGTH OF PRESENTATION:**

0 Minutes (Presentation from Staff)

**SUBMITTED BY:**

Kyle Garner, AICP Planning Director

**BUDGET AMENDMENT REQUIRED:**

N/A



Town of Beaufort  
701 Front St. • P.O. Box 390 • Beaufort, N.C. 28516  
252-728-2141 • 252-728-3982 fax  
[www.beaufortnc.org](http://www.beaufortnc.org)

February 7, 2023

Archie Davis Construction  
515 Island Drive  
Beaufort, NC 28516

RE: Case # 22-36 305 Moore Street – Accessory Structure

Dear Mr. Davis:

Beaufort's Historic Preservation Commission wishes to thank you for your recent application for a Certificate of Appropriateness regarding the property referenced above which is in the Town's Historic District. We appreciate you taking the time to come before the Commission, as well as your willingness to work with us to preserve the distinctive character of Beaufort. Your commitment will help ensure the many historic and cultural resources that we enjoy today will be preserved for future generations.

You have been issued a Certificate of Appropriateness for your project as specified on the enclosed certificate. Please read it carefully. As you proceed with your project, you must comply with all the specifications stated, including provisions in the relevant Historic District Guidelines enumerated on the certificate. Please note the COA must be visibly displayed at the site during the entire duration of the project. Also note that a building permit with the Town may be needed depending on the scope of the work.



Your certificate is valid for the work which must begin within six (6) months from the date of issuance of the COA by the Commission and must be completed no later than one year thereafter. An extension of the COA can be granted upon the Town receiving a written request from the applicant prior to the application expiration date. An extension may only be granted once for a time period of six additional months if the work has been started but not completed within the one-year validation period. Upon completion of your project please contact our office in case an inspection of the project is required.

Thank you for the thought and care that you have dedicated to your project. Your contribution to the preservation of Beaufort's Historic District is greatly appreciated.

Sincerely,

Joyce McCune, Chair  
Beaufort Historic Preservation Commission

Enclosed: COA Certificate  
CC: Ms. Laura Holland

Mayor Sharon Harker  
Commissioner John Hagle • Commissioner Marianna Hollinshed  
Commissioner Bucky Oliver • Commissioner  win Cooper • Commissioner Bob Terwilliger  
Town Manager  Todd Clark



TOWN OF BEAUFORT, NC  
ORDER GRANTING A CERTIFICATE OF APPROPRIATENESS

The Historic Preservation Commission for the Town of Beaufort, N.C. (“HPC”), having held an evidentiary hearing on January 3, 2023 to consider a Certificate of Appropriateness (“COA”) application submitted by Archie Davis Construction for **CASE # 22-36 305 MOORE STREET – ACCESSORY STRUCTURE** and having heard all of the evidence, testimony, and arguments presented during the evidentiary hearing on this item and having the material(s) submitted to the HPC from the applicant, makes the following CONCLUSION:

Based upon the testimony, evidence and record before the HPC on January 3, 2023, we find that the application submitted meets the following design standards under the Design Guidelines for the Beaufort Historic District & Landmarks [revised 2008]:

6.4.7. New windows must match original in overall size and opening area and should have three dimensional muntins with either true divided lights (TDL) or three-dimensional grilles on both the interior and exterior sides (SDL). Snap-in grilles or grilles between glass are not appropriate for windows visible from public view.

6.4.10. New window and door openings shall not alter the historic character of the building or cause damage to historic materials or other significant architectural features. They must be detailed and sized to be compatible with the existing structure.

8.1.13. New tool sheds, swimming pools and other modern yard features should be located in areas not seen from public view.

THEREFORE, IT IS ORDERED based on the application submitted, the testimony given during the evidentiary hearing and the foregoing findings of fact, the HPC concludes that the proposed project is congruous with the special character of the Historic District as a whole and that a Certificate of Appropriateness be **ISSUED** for **CASE # 22-36 305 MOORE STREET – ACCESSORY STRUCTURE**.

This the 7<sup>th</sup> day of February, 2023

\_\_\_\_\_  
Joyce McCune, Chair  
Beaufort Historic Preservation Commission

NOTE: If you are dissatisfied with the decision of this Board, an appeal may be taken to the Beaufort Board of Adjustment within 30 days after the date this order is served on you.



Town of Beaufort  
701 Front St. • P.O. Box 390 • Beaufort, N.C. 28516  
252-728-2141 • 252-728-3982 fax  
[www.beaufortnc.org](http://www.beaufortnc.org)

February 7, 2023

Mr. Jeff Adams  
510 Front Street  
Beaufort, North Carolina 28516

RE: Case # 22-37 510 Front Street - Doors, Windows & Signage

Dear Mr. Adams:

Beaufort's Historic Preservation Commission wishes to thank you for your recent application for a Certificate of Appropriateness regarding the property referenced above which is in the Town's Historic District. We appreciate you taking the time to come before the Commission, as well as your willingness to work with us to preserve the distinctive character of Beaufort. Your commitment will help ensure the many historic and cultural resources that we enjoy today will be preserved for future generations.

You have been issued a Certificate of Appropriateness for your project as specified on the enclosed certificate. Please read it carefully. As you proceed with your project, you must comply with all the specifications stated, including provisions in the relevant Historic District Guidelines enumerated on the certificate. Please note the COA must be visibly displayed at the site during the entire duration of the project. Also note that a building permit with the Town may be needed depending on the scope of the work.

Your certificate is valid for the work which must begin within six (6) months from the date of issuance of the COA by the Commission and must be completed no later than one year thereafter. An extension of the COA can be granted upon the Town receiving a written request from the applicant prior to the application expiration date. An extension may only be granted once for a time period of six additional months if the work has been started but not completed within the one-year validation period. Upon completion of your project please contact our office in case an inspection of the project is required.

Thank you for the thought and care that you have dedicated to your project. Your contribution to the preservation of Beaufort's Historic District is greatly appreciated.

Sincerely,

Joyce McCune, Chair  
Beaufort Historic Preservation Commission

Enclosed: COA Certificate



TOWN OF BEAUFORT, NC  
ORDER GRANTING A CERTIFICATE OF APPROPRIATENESS

The Historic Preservation Commission for the Town of Beaufort, N.C. (“HPC”), having held an evidentiary hearing on January 3, 2023 to consider a Certificate of Appropriateness (COA) application submitted for **CASE # 22-37 510 FRONT STREET - DOORS, WINDOWS & SIGNAGE** and having heard all of the evidence, testimony, and arguments presented during the evidentiary hearing on this item and having the material(s) submitted to the HPC from the applicant, makes the following CONCLUSION:

Based upon the testimony, evidence and record before the HPC on January 3, 2023, we find that the application submitted currently meets the window, door, and signage guidelines of the Local Historic District based on the following design standards under the Design Guidelines for the Beaufort Historic District & Landmarks [revised 2008].

6.4.3. Use replacement windows and doors that match the existing historic elements as closely as possible. Wood windows should be replaced with wood windows. If replacement windows or doors are required, consider first replacing only the deteriorated element, such as a single sash or door, rather than the entire frame or unit. Any new replacements shall match the original in all dimensions, materials, and detailing as closely as possible.

6.4.7. New windows must match original in overall size and opening area and should have three dimensional muntins with either true divided lights (TDL) or three-dimensional grilles on both the interior and exterior sides (SDL). Snap-in grilles or grilles between glass are not appropriate for windows visible from public view.

6.4.10. New window and door openings shall not alter the historic character of the building or cause damage to historic materials or other significant architectural features. They must be detailed and sized to be compatible with the existing structure.

8.6.1. Use traditional materials found in the district, such as wood and metal for new signage. Substitute materials that have the appearance of wood are allowed. Plastic signs, flashing signs, or portable mobile signs, except those listed in item 9, are not allowed in the historic district. Interior neon signs larger than 10” by 18” that are located within five (5) feet of a window or glass door on an exterior wall and are so placed as to be seen from the outside are not allowed. **INTERNAL GLASS MOUNTED SIGNS ARE NOT SUBJECT TO BHPC REVIEW.**

8.6.2. Place signs so that they do not visually overwhelm the building or streetscape or damage or obscure character defining architectural details. Recognize that maximum signage allowances granted by the Beaufort Zoning Ordinance may be inappropriate in the context of the building or site under review.

8.6.3. Signs on commercial buildings are preferred to be located in a signboard frieze located above the display windows. In this location the sign serves as a boundary between the upper and lower façade.

8.6.5. Use simple, clear graphics and lettering styles in sign design.

**THEREFORE, IT IS ORDERED** based on the application submitted, the testimony given during the evidentiary hearing and the foregoing findings of fact, the HPC concludes that the proposed project as it relates to windows, doors, and signage is congruous with the special character of the Historic District as a whole and that a Certificate of Appropriateness be **ISSUED** for **CASE # 22-37 510 FRONT STREET – DOORS, WINDOWS & SIGNAGE ONLY WITH THE CONDITION THAT THE DOOR TO BE ADDED MATCH IN SIZE, SHAPE AND DESIGN TO THE EXISTING ADJACENT DOOR AND BE FINISHED WITH THE SAME TYPE OF MOLDING AND TRIM.**

This the 7<sup>th</sup> day of February 2023

---

Joyce McCune, Chair  
Beaufort Historic Preservation Commission

NOTE: If you are dissatisfied with the decision of this Board, an appeal may be taken to the Beaufort Board of Adjustment within 30 days after the date this order is served on you.



Town of Beaufort  
701 Front St. • P.O. Box 390 • Beaufort, N.C. 28516  
252-728-2141 • 252-728-3982 fax  
[www.beaufortnc.org](http://www.beaufortnc.org)

February 7, 2023

Rebecca Oxholm  
615 Ann Street  
Beaufort, North Carolina 28516

RE: Case # 22-32 615 Ann Street - Landscaping

Dear Ms. Oxholm:

Beaufort's Historic Preservation Commission wishes to thank you for your recent application for a Certificate of Appropriateness regarding the property referenced above which is in the Town's Historic District. We appreciate you taking the time to come before the Commission, as well as your willingness to work with us to preserve the distinctive character of Beaufort. Your commitment will help ensure the many historic and cultural resources that we enjoy today will be preserved for future generations.

You have been issued a Certificate of Appropriateness for your project as specified on the enclosed certificate. Please read it carefully. As you proceed with your project, you must comply with all the specifications stated, including provisions in the relevant Historic District Guidelines enumerated on the certificate. Please note the COA must be visibly displayed at the site during the entire duration of the project. Also note that a building permit with the Town may be needed depending on the scope of the work.

Your certificate is valid for the work, which must begin within six (6) months from the date of issuance of the COA by the Commission and must be completed no later than one year thereafter. An extension of the COA can be granted upon the Town receiving a written request from the applicant prior to the application expiration date. An extension may only be granted once for a time period of six additional months if the work has been started but not completed within the one-year validation period. Upon completion of your project please contact our office in case an inspection of the project is required.

Thank you for the thought and care that you have dedicated to your project. Your contribution to the preservation of Beaufort's Historic District is greatly appreciated.

Sincerely,

Joyce McCune, Chair  
Beaufort Historic Preservation Commission

Enclosed: COA Certificate



TOWN OF BEAUFORT, NC  
ORDER GRANTING A CERTIFICATE OF APPROPRIATENESS

The Historic Preservation Commission for the Town of Beaufort, N.C. (“HPC”), having held an evidentiary hearing on January 3<sup>rd</sup> 2023 to consider a Certificate of Appropriateness (“COA”) application submitted for **CASE # 22-32 615 ANN STREET – LANDSCAPING** and having heard all of the evidence, testimony, and arguments presented during the evidentiary hearing on this item and having the material(s) submitted to the HPC from the applicant, makes the following CONCLUSION:

Based upon the testimony, evidence and record before the HPC on January 3<sup>rd</sup> 2023, we find that the application submitted meets the following design standards under the Design Guidelines for the Beaufort Historic District & Landmarks [revised 2008]:

8.1.5. All new plant materials selected for replanting or new planting in publicly visible areas should complement as much as possible those found on the site and in the surrounding area of the district.

8.2.4. Historic retaining walls should be preserved. New low walls are appropriate only where a sharp change in grade exists and shall not exceed a height of two (2) feet. Such walls should be constructed of brick or concrete block covered with a true sand-finish stucco.

THEREFORE, IT IS ORDERED based on the application submitted, the testimony given during the evidentiary hearing and the foregoing findings of fact, the HPC concludes that the proposed project is congruous with the special character of the historic district as a whole and that a Certificate of Appropriateness be **ISSUED** for **CASE # 22-32 615 ANN STREET – LANDSCAPING**.

This the 7<sup>th</sup> day of February 2023

\_\_\_\_\_  
Joyce McCune, Chair  
Beaufort Historic Preservation Commission

NOTE: If you are dissatisfied with the decision of this Board, an appeal may be taken to the Beaufort Board of Adjustment within 30 days after the date this order is served on you.



**Town of Beaufort, NC**

701 Front St. - P.O. Box 390 - Beaufort, N.C. 28516  
252-728-2141 - 252-728-3982 fax - www.beaufortnc.org

**Town of Beaufort Historic Preservation Commission Regular Meeting  
6:00 PM Tuesday, February 7, 2023 – 614 Broad Street – Train Depot**

---

**AGENDA CATEGORY:** Old Business  
**SUBJECT:** Case # 22-22 211 Broad Street – Raising Existing Structure with New Steps and Chimney work

**BRIEF SUMMARY:**

In August of 2022 the Commission tabled this item until the applicant could provide information from a structural engineer as to the need for elevation the structure to 24 inches above current elevation. The engineer has supplied a letter of their findings and should attend the meeting to answer any questions.

**REQUESTED ACTION:**

Reconvene the Quasi- Judicial Hearing

**EXPECTED LENGTH OF PRESENTATION:**

15 Minutes

**SUBMITTED BY:**

Kyle Garner

**BUDGET AMENDMENT REQUIRED:**

N/A



# BHPC STAFF REPORT



**To:** BHPC Members  
**From:** Kyle Garner, Planning Director  
**Date:** January 5, 2023  
**Case No.** 22-22

**Request:** Elevate Existing Structure at 211 Broad Street 24” with new steps  
**Applicant:** Billy Tickle, Superior Structures  
 P.O. Box 185  
 Beaufort, NC

**Property Information:**

**Owners:** Elizabeth & Don Patterson  
**Location:** 211 Broad Street  
**PIN#:** 730617113409000

**Project Information:** In the District Survey, updated by Ruth Little, 211 Broad is described as **House** c. 1900 (plaque). 1 story 3-bay cottage with center hall plan has moulded eave returns, 1 exterior brick chimney, Craftsman-style 3-light door with transom, 9/6 and 4/4 sash. Hipped porch has chamfered posts, beaded rail, and plain balustrade. Area first mapped by Sanborn in 1908; house appears on this map.

**In August of 2022 the Commission tabled this item until the applicant could provide information from a structural engineer as to the need for elevation the structure to 24 inches above current elevation. The engineer has supplied a letter of their findings and should attend the meeting to answer any questions.**

**Proposed work:**

- See Attachment from Applicant

**Material:**

- See Material Submitted by Applicant

**Color:**

See Attached Description from Applicant.

**Attachments:**

- Area map
- List of adjacent property owners used for mailing notifications
- COA application and supporting materials supplied by applicant to include photos

**Brickwork and Masonry Guidelines:**

6.3.1 Retain and preserve historic brick and masonry elements, including walls, chimneys, foundations, and retaining walls. Preserve masonry elements that are character-defining features of the building or property.

6.3.8. When replacing damaged brick or stone, use replacements that match the original units as closely as possible.

**Foundations Guidelines**

If new foundation infill or underpinning is required, or if large areas of old foundations must be rebuilt for structural reasons, construct the new foundation with distinct piers with the infill brickwork or curtain wall recessed 1” to 2” back from the outer face of the piers. Never build infill flush with the face of the piers. Use bricks that are compatible with the historic bricks or the period of the structure. Concrete block may be used for piers and infill only when covered with a veneer of brick or sand-finished stucco. Wood grilles and lattice were historically used in Beaufort and are appropriate when they are compatible with the period and style of the structure. Lightweight or “stock” lattice is not appropriate in areas visible from the public view.

6.6.4. New vents or access doors should be centered between piers. Use inconspicuous vents, such as black iron or dark plastic, rather than unpainted aluminum. Locate access doors and other new openings in areas not visible from public view.

6.6.5. For infilling between existing brick piers, construct a curtain wall that is recessed approximately 1” to 2” back from the outer face of the piers so the original piers stand out; use this treatment for both old and new foundations. Flush foundations and infill are not appropriate. Concrete block may be used only if covered with a veneer of brick or sand-finished stucco. Leave foundations under porches open wherever possible to promote air circulation to prevent rot and deterioration; use wood lattice or grilles to enclose.

6.6.6. Wood grilles or lattice are appropriate for infill if compatible with the period or style of the structure. Stock lightweight lattice is not appropriate in areas in the public view.

6.6.9. The raising of a building’s foundation should be undertaken for sound structural and/or flood control reasons ONLY, and these reasons should be well-documented by flood maps, an architect or engineer’s report accompanying an owner’s COA application.

**Porches and Entrances Guidelines**

6.5.7. Use architectural details and ornamentation that are compatible with the style, period, and detailing of the porch and structure. Such features as new metal columns or wrought iron posts, over-scaled columns with elaborate capitals, metal or plastic balustrades are not allowed. The creation of a false historical appearance, such as adding Victorian ornament to a plain early 20th century porch, is not appropriate.

# BHPC Case 22-22 211 Broad Street - Raising Structure Elevation

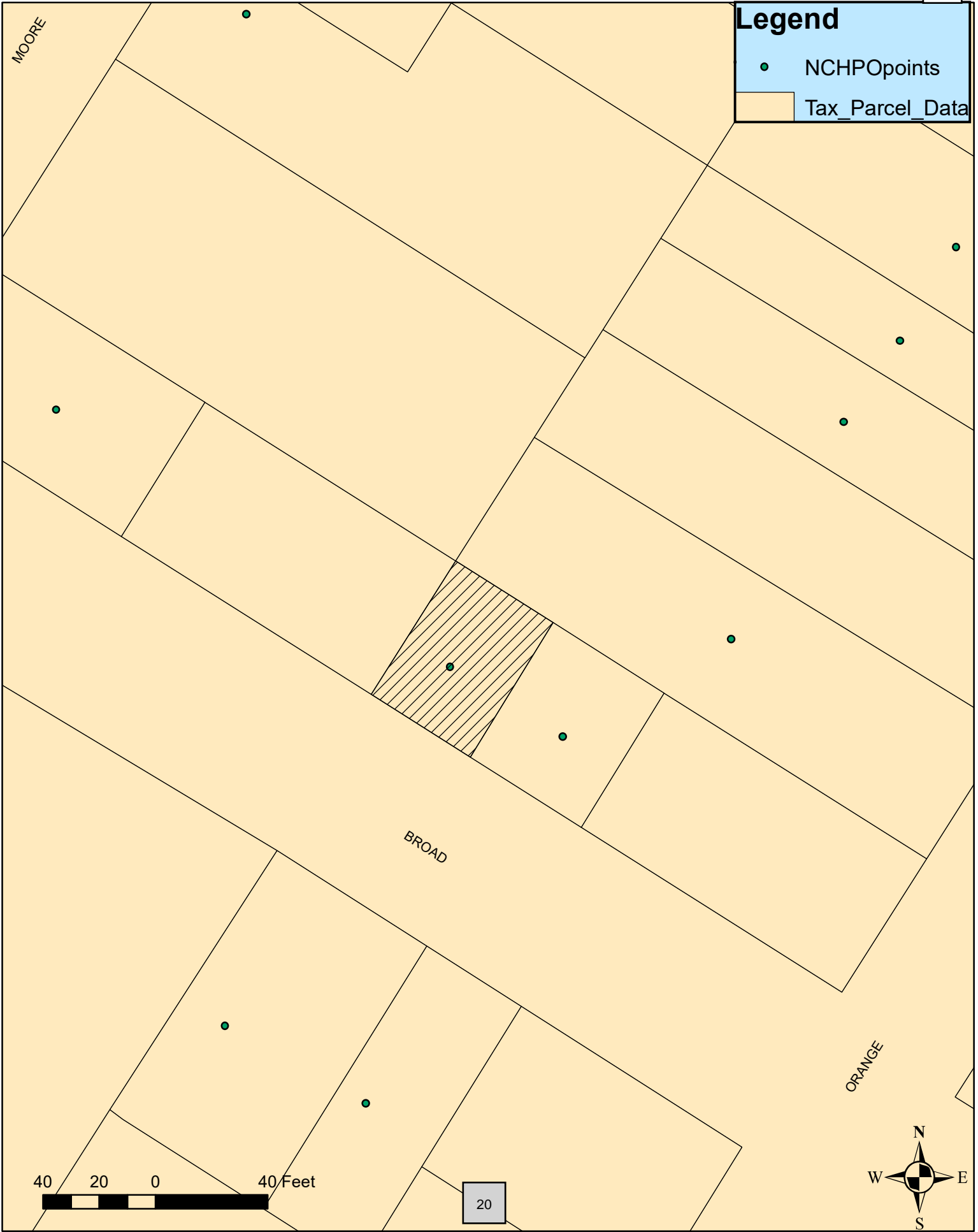

**Legend**

- NCHPO points
- Tax\_Parcel\_Data

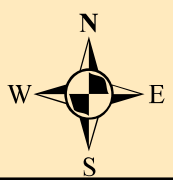
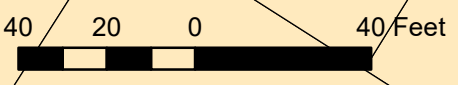

20

<u>OWNER</u>	<u>MAIL_HOL</u>	<u>MAIL_ST</u>	<u>MAIL_CITY</u>	<u>IL_ST</u>	<u>MAIL_ZI</u>	<u>MAIL_ADD2</u>
LAWRENCE,EARLENE R	600	NORTH 35TH STREET	MOREHEAD CITY	NC	28557	UNIT 301
NC COASTAL LIFE LLC	210	BROAD STREET	BEAUFORT	NC	28516	C/O NICOLETTE DUNN
PATTERSON,ELIZABETH F ETAL DON	206	EAST GRAVERS LANE	PHILADELPHIA	PA	19118	
PICKERING,SANDRA ET VIR JEFFREY	203	BROAD ST	BEAUFORT	NC	28516	
ST PAULS EPISCOPAL CHURCH	209	ANN STREET	BEAUFORT	NC	28516	
ULRICH,ROBERT G ET UX LISA B	213	BROAD STREET	BEAUFORT	NC	28516	
WILSON,MAMRE	302	MOORE STREET	BEAUFORT	NC	28516	

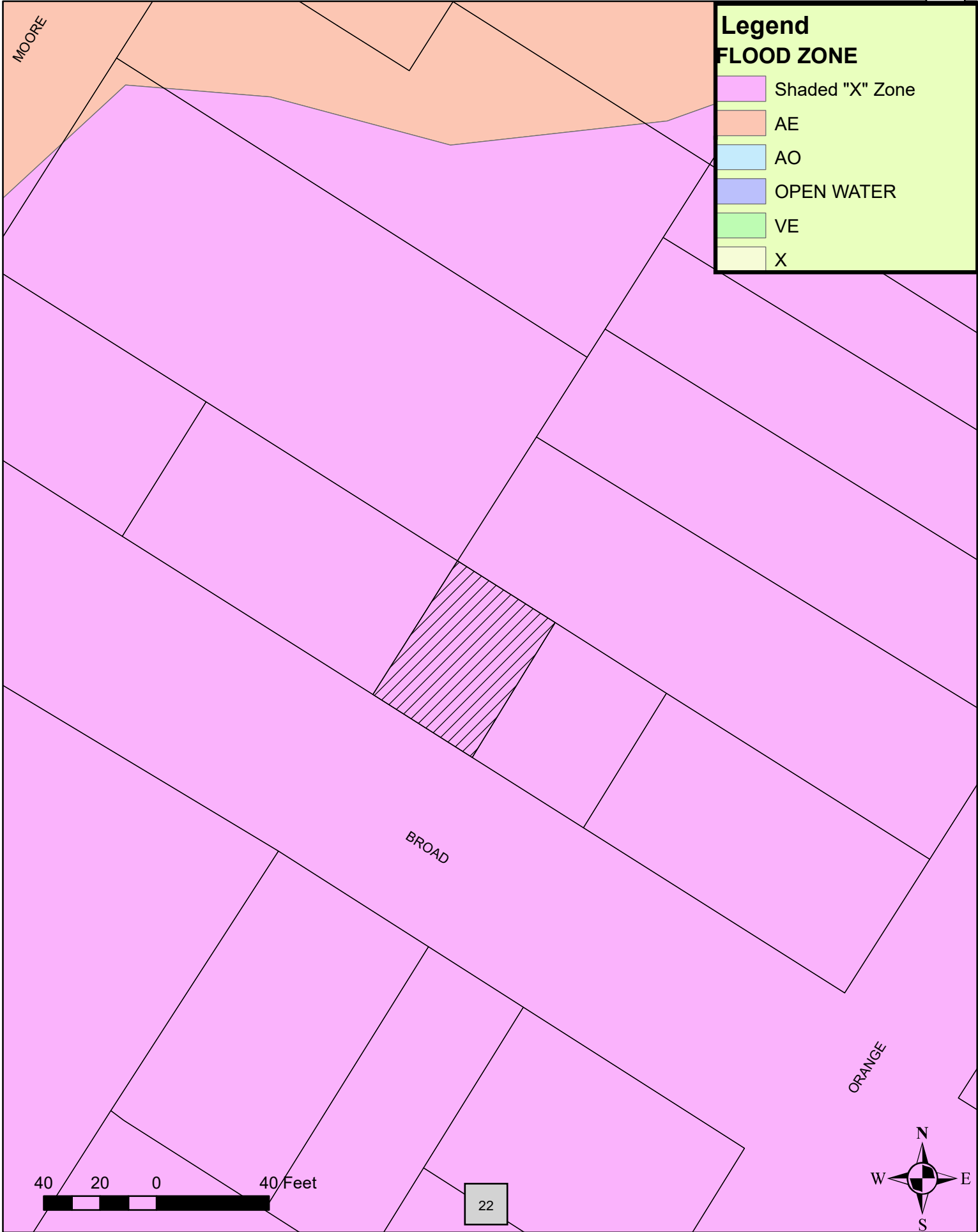

**CERTIFICATE OF APPROPRIATENESS APPLICATION  
FOR PROJECTS WITHIN THE BEAUFORT HISTORIC DISTRICT**



**Instructions:**

Please complete the application below and include all attachments as noted on page 2 of this application along with a **\$250.00 application fee** and return to the Beaufort Town Hall; 701 Front Street or P.O. Box 390, Beaufort, N.C. 28516. Incomplete applications will not be processed and **will be** returned to the applicant. Please contact Town Hall at 252-728-2142 if there are any questions.

**APPLICANT/OWNER INFORMATION**

Please print!

Applicant Name: ST Development Co., Inc.

Applicant Address: PO Box 185 Beaufort, NC 28516

Business Phone: 252-228-4170 Email/Cell: 252-808-7337

Property Owner Name: Elizabeth + Don Padgugon

Address of Property: 211 Broad St. Beaufort NC, 28516

Phone Number: 1-215-852-9091 Email/Cell: \_\_\_\_\_

**PROJECT INFORMATION**

Detailed description of the Proposed Project (please attach additional pages if necessary):

We propose to raise 211 Broad St. to an elevation so as to perform repairs to floor system. The house will then be lowered onto a new brick foundation (Phoenix bricks) with final elevation approximately 24" above side walk. New steps will be pressure treated wood.

Estimated Cost of Project: \$ 29,500.00

Year House Built: 1910

ST Development Co., Inc.  
Applicant Signature

02/12/22  
Date

Property Owner Signature (if different than above)

Date

An application fee of \$250.00, either in cash, money order, or check made payable to the "Town of Beaufort" must accompany this application (a credit or debit card payment can be made in person at Town Hall). The complete application, payment, and supporting material must be received by Town Staff by the posted submittal dates noted on the Historic Preservation's calendar found on the Town's website at [www.beaufortnc.org](http://www.beaufortnc.org). The Commission meets 23ly on the first Tuesday of the month unless it is a holiday.

**Kyle Garner**

---

**From:** Billy Tickle <superiorstructures86@gmail.com>  
**Sent:** Tuesday, July 12, 2022 3:49 PM  
**To:** Kyle Garner  
**Subject:** 211 Broad St.  
**Attachments:** KIMG1764.JPG

Kyle,  
Existing concrete steps at 211 Broad St. New steps will be pressure treated with 3 or 4 steps. Thanks, Billy



**Kyle Garner**

---

**From:** Billy Tickle <superiorstructures86@gmail.com>  
**Sent:** Tuesday, July 12, 2022 3:46 PM  
**To:** Kyle Garner  
**Subject:** 211 Broad St.  
**Attachments:** KIMG1765.JPG

Kyle,  
Expanded photo of Phoenix brick at 608 Broad St. proposed for 211 Broad St.



**Kyle Garner**

---

**From:** Billy Tickle <superiorstructures86@gmail.com>  
**Sent:** Tuesday, July 12, 2022 3:45 PM  
**To:** Kyle Garner  
**Subject:** 211 Broad St.  
**Attachments:** KIMG1766.JPG

Kyle,  
Phoenix brick foundation at 608 Broad St. 24 inch height above sidewalk.

**Kyle Garner**

---

**From:** Billy Tickle <superiorstructures86@gmail.com>  
**Sent:** Thursday, July 14, 2022 12:38 PM  
**To:** Kyle Garner  
**Subject:** 211 Broad St.

Kyle,  
We also propose to keep old chimney and raise it up along with the house lift. Thanks, Billy







**THE CULLIPHER GROUP, P.A.**  
**ENGINEERING & SURVEYING SERVICES**  
C-4482

December 15, 2022

Mr. Kyle Garner  
701 Front St.  
Beaufort, NC 28516

Re: Beaufort Historic Preservation Commission - 211 Broad Street Foundation Repair

Dear Mr. Kyle Garner:

In accordance with "Beaufort Historic Design Guidelines" Section 6.6.9, I performed an inspection of the foundation of the home located at 211 Broad Street on December 14<sup>th</sup>, 2022 and found it to be inadequate for supporting the existing structure and floor system. The floor internal to the dwelling sags and moves and is in disrepair due to the typical construction methods used at the time the house was built. I recommend that the house be temporarily lifted approximately 6'-to-8' to allow a contractor access to remove/repair/replace the concrete piers and beams supporting this structure. In order to properly perform this service the finished floor elevation should also be raised approximately 6-to-8 inches higher than it currently is, resulting in a finished floor elevation that is nearly 24" above the ground. This increase in crawlspace height shall allow for improved structural stability while also being in similar height and appearance as many homes on Broad Street and in the Town of Beaufort's Historic District in general.

Sincerely,

*Charles M. Cullipher*  
Charles M. Cullipher, PE  
The Cullipher Group, PA

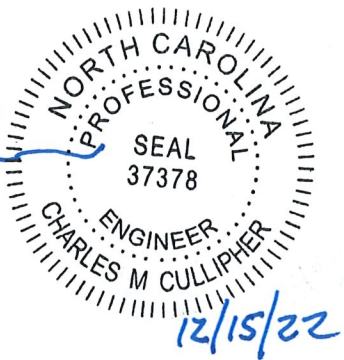



**Town of Beaufort, NC**

701 Front St. - P.O. Box 390 - Beaufort, N.C. 28516  
252-728-2141 - 252-728-3982 fax - www.beaufortnc.org

**Town of Beaufort Historic Preservation Commission Regular Meeting  
6:00 PM Tuesday, January 3, 2023 – 614 Broad Street – Train Depot**

---

**AGENDA CATEGORY:** New Business  
**SUBJECT:** Case # 22-35 211 Orange Street – Driveway, Landscaping & Landscape Lighting

**BRIEF SUMMARY:**

The applicant wishes to install pavers for their driveway and install new landscaping with lighting within the landscaping.

**REQUESTED ACTION:**

Conduct Quasi- Judicial Hearing

**EXPECTED LENGTH OF PRESENTATION:**

15 Minutes

**SUBMITTED BY:**

Kyle Garner

**BUDGET AMENDMENT REQUIRED:**

N/A

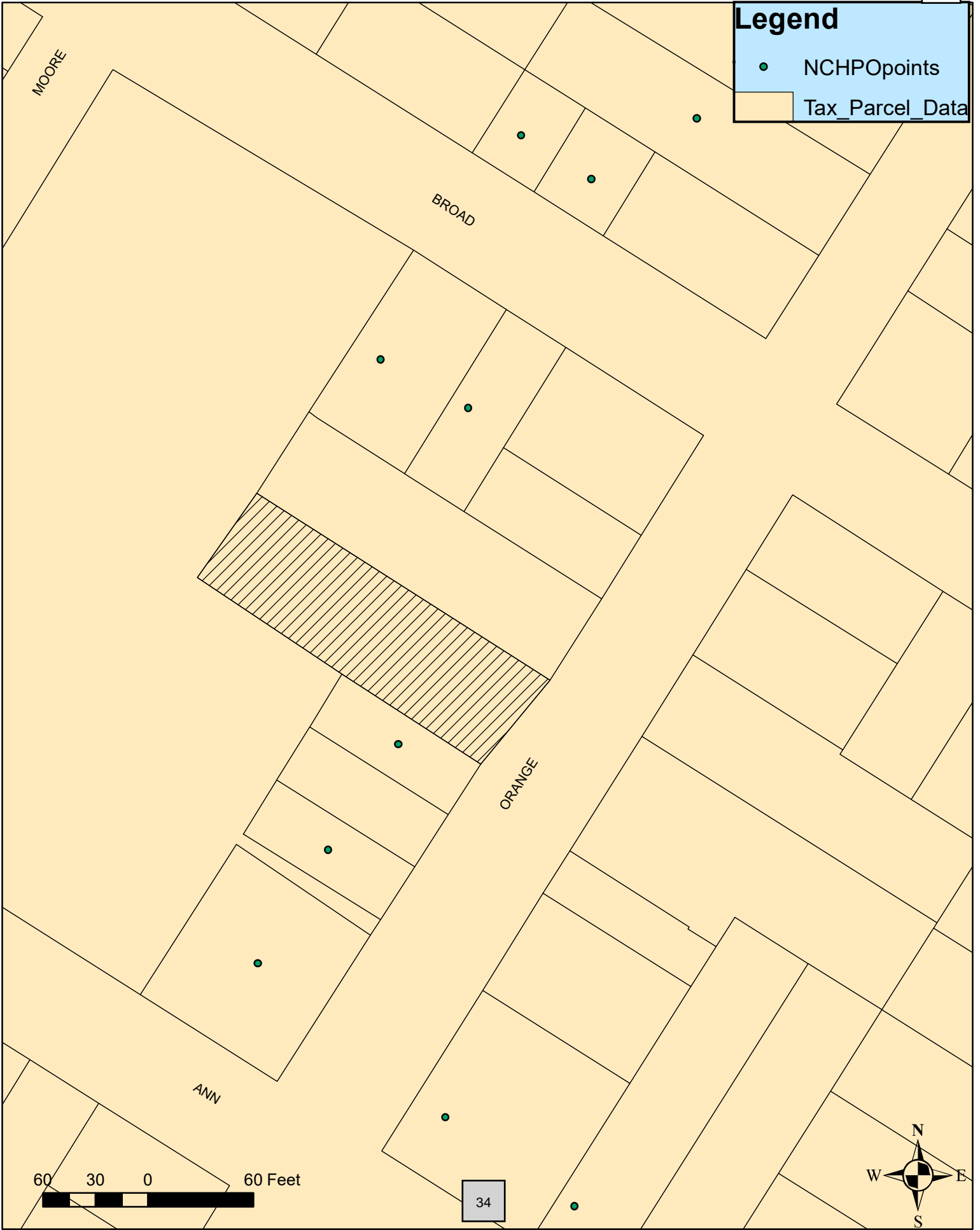

**Legend**

- NCHPO points
- Tax\_Parcel\_Data

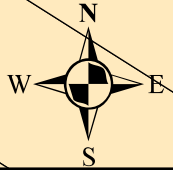
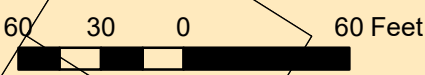

34



# BHPC STAFF REPORT



**To:** BHPC Members  
**From:** Kyle Garner, Planning Director  
**Date:** December 20, 2022  
**Case No.** 22-35

**Request:** To move install driveway pavers, new landscaping, and landscape lighting.

**Applicant:** Allison Daniel  
 211 Orange Street  
 Beaufort, NC 28516

**Property Information:**

**Owners:** Same  
**Location:** 211 Orange Street  
**PIN#:** 730617112139000

**Project Information:** 1997 - COA was granted for a new dove grey asphalt shingles.  
 1998 – COA was granted for a fence.

**Proposed work:**

- See Attachment from Applicant

**Material:**

- See Information from Applicant.

**Color:** See Attached Description from Applicant.

**Attachments:**

- Vicinity Map
- List of adjacent property owners used for mailing notifications
- COA application and supporting materials supplied by applicant.

## Off-street Parking Guidelines

8.5.5. Integrate pedestrian scale lighting into parking areas to avoid excessive glare and illumination to adjoining properties. See EXTERIOR LIGHTING guidelines and the Beaufort Zoning Ordinance for further details on lighting standards.

8.5.7. Use paving materials that were traditionally used on surface parking areas and driveways on the surrounding block or street. Gravel, marl, crushed shells, asphalt, and concrete are typical parking lot treatments, while grass, gravel or concrete runners with a grassy median, brick, and marl are typical driveway treatments. Use bricks, stone, or metal to contain loose paving materials. Landscaping timbers, railroad ties, and concrete or plastic edging are not allowed.

## Landscaping Guidelines

8.1.4. Plant smaller trees species in the planting strips adjacent to public streets only if utility lines or other overhead obstructions exist. Use species such as crape myrtle, cedar, dogwood, redbud, Carolina cherry laurel and sweet bay magnolia.

8.1.5. All new plant materials selected for replanting or new planting in publicly visible areas should complement as much as possible those found on the site and in the surrounding area of the district.

8.1.6. Palms, banana trees and other tropical type landscape materials should not dominate the landscape palette. Sabal palms may be used as a minor landscape element. Likewise, any use of other tropical style plant materials that can be viewed from the public property should be limited to a minor complementary presence. Traditional plant materials including live oak trees, deciduous shade and understory trees (service berry or dogwood) and broadleaf evergreen and deciduous shrubs should dominate the landscape.

8.1.7. Maintain the relationship between the mass/proportion of the building and open space within the context of the streetscape for new construction, additions and landscape.

8.1.10. Contemporary edging or border materials, such as exposed landscape timbers, railroad ties, pre-cast concrete, plastic, or other substitute material borders are not appropriate in areas seen from the public view.

## Exterior Lighting Guidelines

8.4.4. Use ground-mounted spots or ornamental light fixtures to illuminate signs instead of internal lighting. Screen spots and accent lighting from view.

8.4.5. All lighting should be directed toward the property for which it was intended and should not spill over onto adjacent properties.

<u>OWNER</u>	<u>MAIL_HOU</u>	<u>MAIL_ST</u>	<u>MAIL_CITY</u>	<u>IL_ST</u>	<u>MAIL_ZIP</u>
BARNES,GAIL RACKLEY	385	CHEROKEE AVE SE	ATLANTA	GA	2230 30312
DANIEL,ALLISON D	211	ORANGE STREET	BEAUFORT	NC	28516
MEADOWS,ROBERT K ETUX CAROLYN	210	ORANGE ST	BEAUFORT	NC	28516
RODDEWIG,ROBBIN E ETUX JENNIFE	104	NEWHALL PLACE SW	LEESBURG	VA	20175
ST PAULS EPISCOPAL CHURCH	209	ANN STREET	BEAUFORT	NC	28516



**CERTIFICATE OF APPROPRIATENESS APPLICATION  
FOR PROJECTS WITHIN THE BEAUFORT HISTORIC DISTRICT**



**Instructions:**

Please complete the application below and include all attachments as noted on page 2 of this application along with a \$250.00 application fee and return to the Beaufort Town Hall: 701 Front Street or P.O. Box 390, Beaufort, N.C. 28516. Incomplete applications will not be processed and will be returned to the applicant. Please contact Town Hall at 252-728-2142 if there are any questions.

**APPLICANT/OWNER INFORMATION**

*Please print*

Applicant Name: Allison Dorr Daniel  
Applicant Address: 211 Orange St. Beaufort, NC 28516  
Business Phone: 252-532-3696 Email/Cell: allison.daniel@gmail.com  
Property Owner Name: same  
Address of Property: \_\_\_\_\_  
Phone Number: \_\_\_\_\_ Email/Cell: \_\_\_\_\_

**PROJECT INFORMATION**

Detailed description of the Proposed Project (please attach additional pages if necessary):

Driveway - add pavers per plan  
Landscape - add Granite garden edging per plan  
Landscape lighting - add path and uplight per plan

Estimated Cost of Project: \$ 4300.00 Year House Built: 1892

x Allie Dorr Daniel Date 12/04/22  
Applicant Signature

Property Owner Signature (if different than above) \_\_\_\_\_ Date \_\_\_\_\_

*An application fee of \$250.00, either in cash, money order, or check made payable to the "Town of Beaufort" must accompany this application (a credit or debit card payment can be made in person at Town Hall). The complete application, payment, and supporting material must be received by Town Staff by the posted submittal dates noted on the Historic Preservation's calendar found on the Town's website at [www.beaufortnc.org](http://www.beaufortnc.org). The Commission meets regularly on the first Tuesday of the month unless it is a holiday.*

**OFFICE USE ONLY**

Received by: \_\_\_\_\_ Reviewed for Completeness: \_\_\_\_\_  
Date: \_\_\_\_\_ Date Deemed Completed and Accepted: \_\_\_\_\_

# AMERICAN LANDSCAPES

*americanlandscapesnc.com*

*P.O. Box 1771 Southern Pines, NC 28388  
910-295-1252*

*Shawn M. Sazama*

*President  
licensed landscape, irrigation and pesticide  
contractor*



Allison Daniel Residence  
211 Orange Street  
Beaufort, NC 28516  
Landscape Plan  
12/04/2022  
American Landscapes

## Adjacent Property Owners

Robbin and Jennifer Roddewig  
209 Orange Street  
Beaufort, NC 28516

Gail Barnes  
213 Orange Street  
Beaufort, NC 28516

**AMERICAN  
LANDSCAPES**  
*americanlandscapesnc.com*

*P.O. Box 1771 Southern Pines, NC 28388  
910-295-1252*

***Shawn M. Sazama***

*President  
licensed landscape, irrigation and pesticide  
contractor*

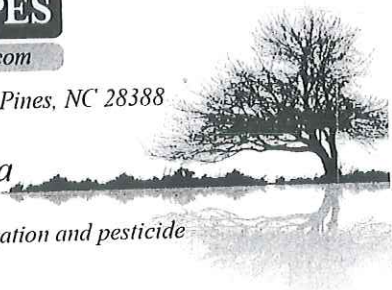

Allison Daniel Residence  
211 Orange Street  
Beaufort, NC 28516  
Landscape Plan  
12/04/2022  
American Landscapes



# AMERICAN LANDSCAPES

[americanlandscapesnc.com](http://americanlandscapesnc.com)

P.O. Box 1771 Southern Pines, NC 28388  
910-295-1252

*Shawn M. Sazama*

*President  
licensed landscape, irrigation and pesticide  
contractor*

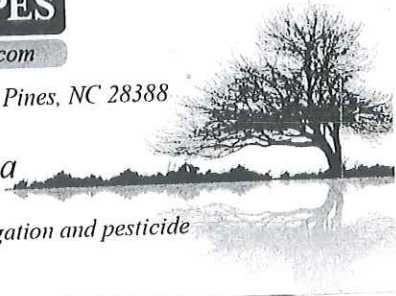

Allison Daniel Residence  
211 Orange Street  
Beaufort, NC 28516  
Landscape Plan  
12/04/2022  
American Landscapes



# AMERICAN LANDSCAPES

[americanlandscapesnc.com](http://americanlandscapesnc.com)

P.O. Box 1771 Southern Pines, NC 28388  
910-295-1252

*Shawn M. Sazama*

*President  
licensed landscape, irrigation and pesticide  
contractor*

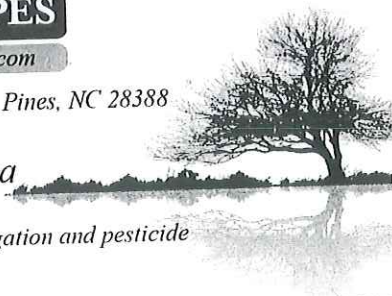

Allison Daniel Residence  
211 Orange Street  
Beaufort, NC 28516  
Landscape Plan  
12/04/2022  
American Landscapes



# AMERICAN LANDSCAPES

[americanlandscapesnc.com](http://americanlandscapesnc.com)

P.O. Box 1771 Southern Pines, NC 28388  
910-295-1252

*Shawn M. Sazama*

*President  
licensed landscape, irrigation and pesticide  
contractor*

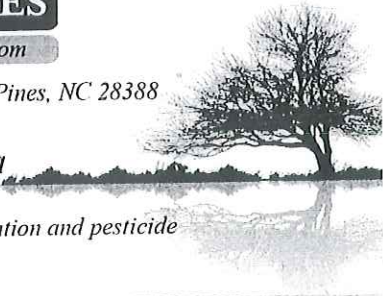

Allison Daniel Residence  
211 Orange Street  
Beaufort, NC 28516  
Landscape Plan  
12/04/2022  
American Landscapes



# Detail "A"

• Driveway edge Pavers and planting bed edging:

- Allison Daniel Residence -

Scale: 1" = 12'-0"

- American Landscapes -  
drawn M. Szame

REL# 0359  
210160

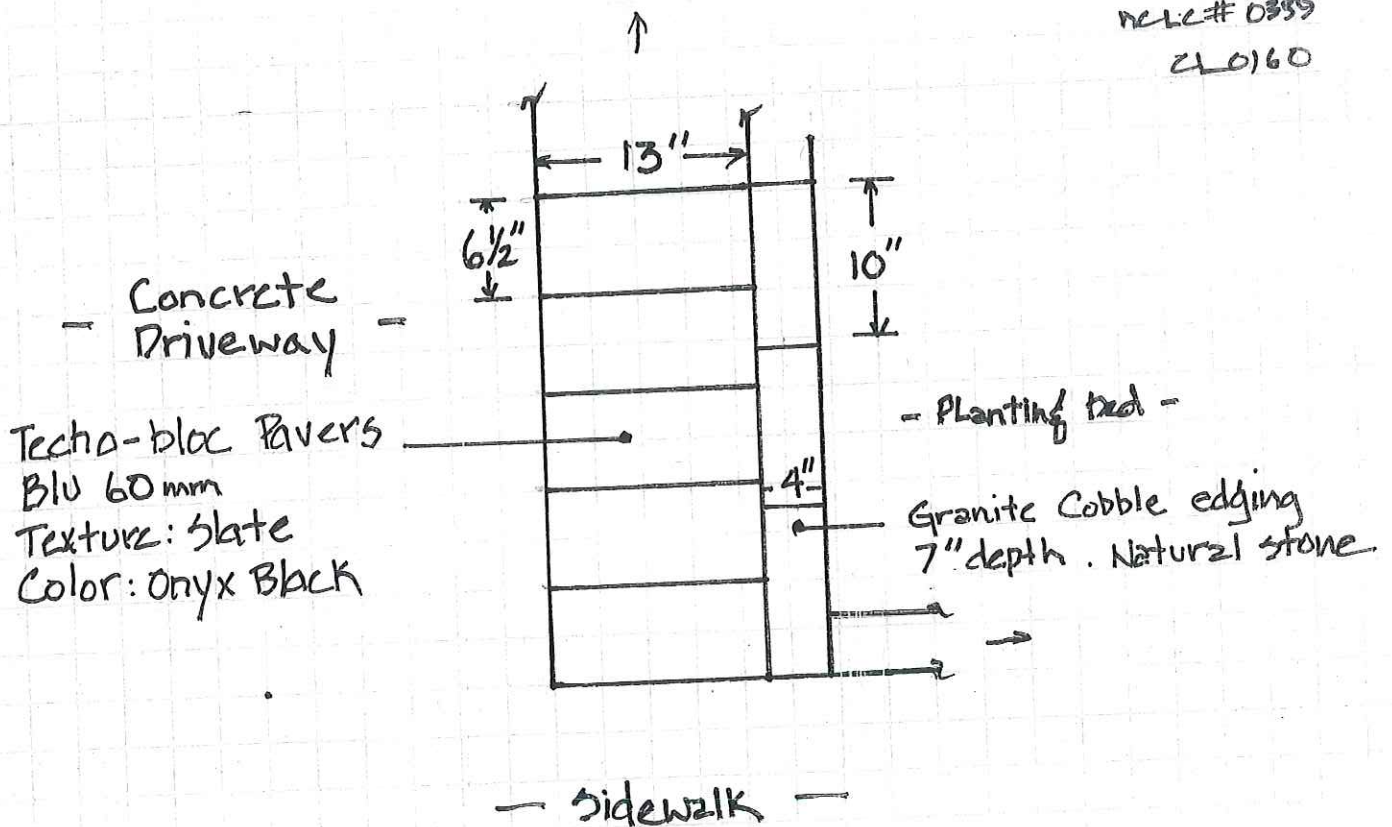

# Detail "B"

- Planting bed edging •
- Allison Daniel Residence -
- scale: 1" = 12" - 0"
- American Landscapes -  
Shawn M. Szama

NLLC # 0539  
# 440160

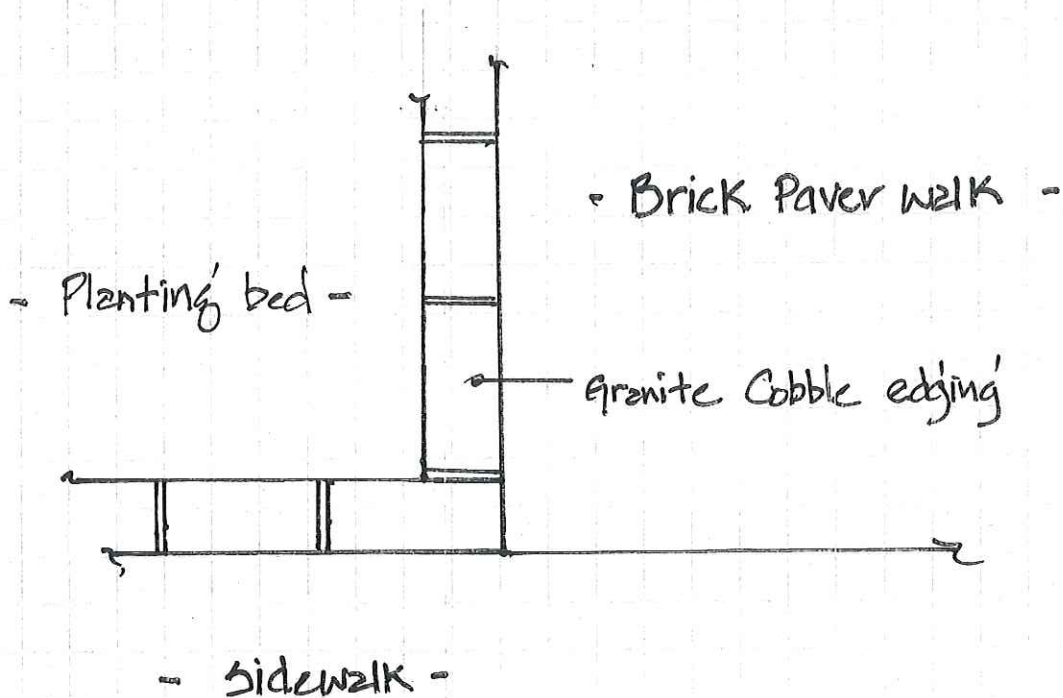

Detail "C"

- Garden Path Pavers •
- Allison Daniel Residence -
- Scale: 1" = 12" - 0"
- American Landscapes  
Shawn M. Szama

NELC # 0339  
CL 0160

11/27/22

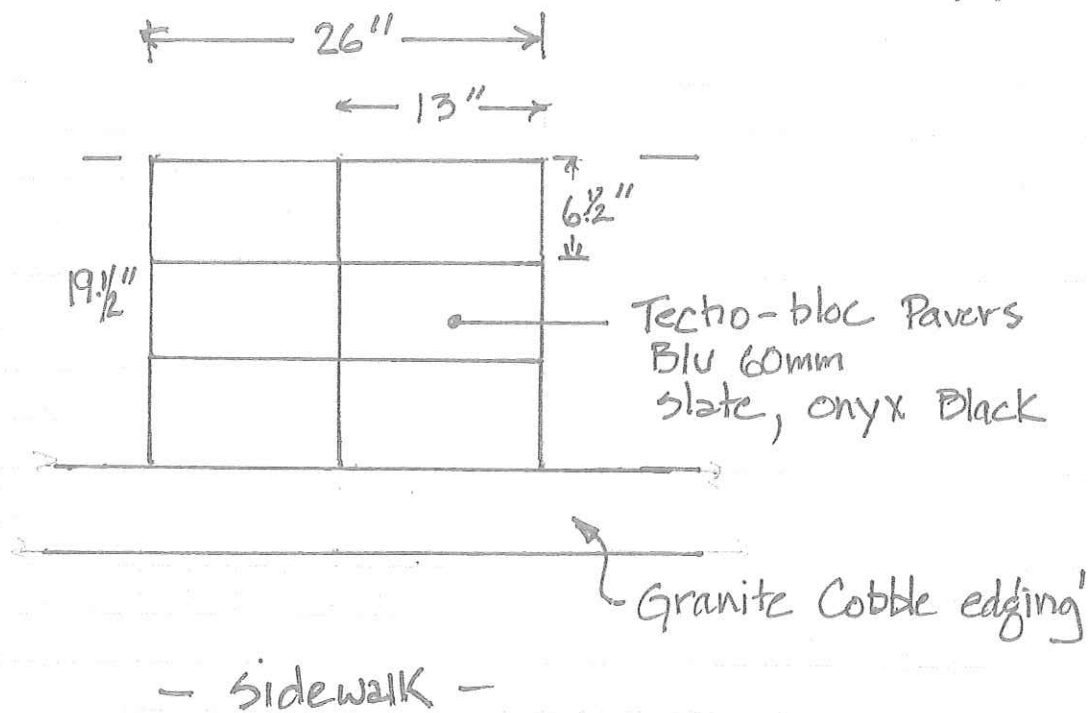



# BLU 60 mm (6"×13")

DESCRIPTION: Slab TEXTURE: Slate and HD² Slate

## PALLET OVERVIEW

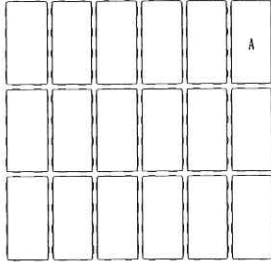

Specifications per pallet	Imperial	Metric
Cubing	116.05 ft <sup>2</sup>	10.78 m <sup>2</sup>
Approx. Weight Slate	3 138 lbs	1 423 kg
Approx. Weight HD <sup>2</sup> Slate	3 183 lbs	1 444 kg
Number of rows	11	
Coverage per row	10.55 ft <sup>2</sup>	0.98 m <sup>2</sup>
Linear coverage per row	Depth 19.5 lin. ft	5.94 lin. m
	Length 9.75 lin. ft	2.97 lin. m



Unit dimensions	in		mm		Units/pallet
	in	mm	in	mm	
Height	2 3/8	60	2 3/8	60	198 units
Width	13	330	13	330	
Length	6 1/2	165	6 1/2	165	

## NOTES

See page 35 to 37 for more technical information. When used in a permeable pavement application, see page 33 and 101 for more technical information.

See page 29 for more information about applications.

\*HD<sup>2</sup> Slate is only available in USA.

**JOINT WIDTH:** 9/32" (7 mm)  
**% OF SURFACE OPENING:** 4.6 %  
**INFILTRATION RATE:** 570 in./hr (14 475 mm/hr)

- Techo-bloc  
 Blu 60 mm  
 Slab Texture: Slate  
 paver  
 6" x 13" x 2 3/8"

08 | Linear pattern



09 | Linear pattern

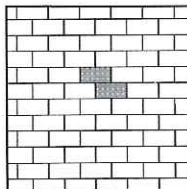

10 | Parquet pattern

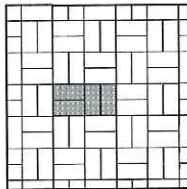

11 | Herringbone pattern

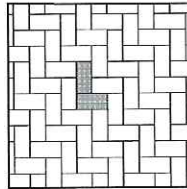

Patterns are for design inspiration only. The installer is responsible to calculate & purchase the correct amount of material.

Chocolate Brown Slate  
 Chestnut Brown HD<sup>2</sup> Slate\*  
 Champlain Grey HD<sup>2</sup> Slate\*  
 Shale Grey HD<sup>2</sup> Slate\*  
 Onyx Black HD<sup>2</sup> Slate\*

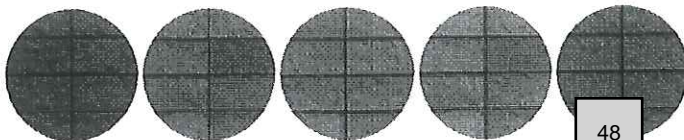

Allison Daniel  
 Residence  
 Landscape

973-334-5522  
187 March St.  
Fort Newark, NJ 07114

High Bridge Stone Company



Alison Daniel Residence / Landscape / Granite Cobble edging

Granite Cobble stone (grey)

COBB-0012 4'x7'9"

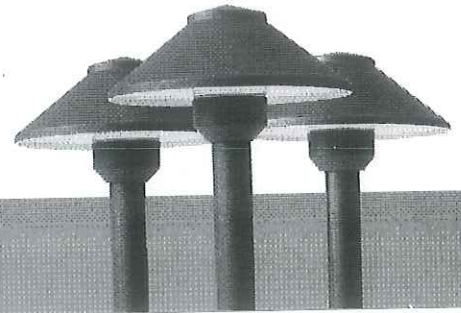

**PT-PTH1**

Product: PT-PTH1-BK-LED Type: Path light  
 Project: Allison Dancel Residence

FINISH	PRODUCT CODE	HOUSING	DIAMETER	HEIGHT	LED
Bronze	PT-PTH1-BZ-LED	Aluminum	6.1"	19"	T3 Included: 2.5W, 2700K, 180 Lumens
Black	PT-PTH1-BK-LED	Aluminum	6.1"	19"	T3 Included: 2.5W, 2700K, 180 Lumens
Antique	PT-PTH1-BS-LED	Brass	6.1"	19"	T3 Included: 2.5W, 2700K, 180 Lumens

**SPECIFICATIONS**

**CONSTRUCTION:**

- Aluminum or Brass Housing
- EPDM Rubber Plug in Base
- Dual Silicone O-Rings for Watertight Seal

**LENS:**

- Heat-Resistant Polycarbonate

**LAMP:**

- Includes Pro-Trade 2.5W, 2700K T3 LED Lamp
- 20W Max

**POWER:**

- Input Voltage 10-15V

**SOCKET:**

- High-Temperature Ceramic
- G4 Bi-Pin with Nickel Contacts
- Heat-Resistant Leads

**MOUNT:**

- Includes ABS Slotted Ground Stake

**WIRING:**

- Pre-Wired with Three Ft. SPT-2W Lead Wire

**WARRANTY:**

(Free from Material Defects and/or Workmanship)

- Brass: Lifetime
- Aluminum: Five Years

**CERTIFICATIONS:**

- ETL Listed to UL Standard 1838 and CAN/CSA-22.2 No. 250.7

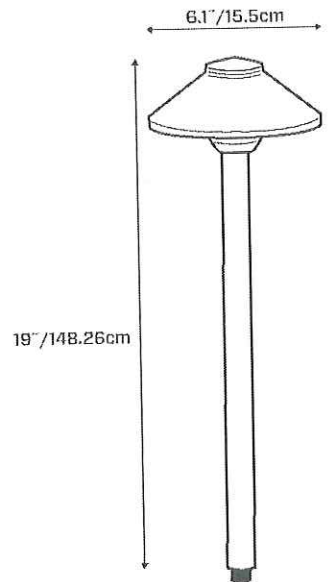

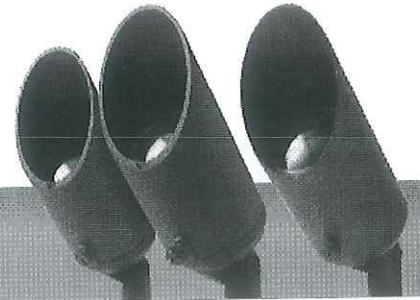

# PT-BUL1

Product: PT-BUL1-BK-LED-3FL Type: Landscape uplight  
 Project: Allison Daurzel Residence

FINISH	PRODUCT CODE	HOUSING	LED
● Bronze	PT-BUL1-BZ-NL	Aluminum	Sold Separately
	PT-BUL1-BZ-LED-3FL	Aluminum	MR16 Included: 3W, 38°, 2700K, 250 Lumens
● Black	PT-BUL1-BK-NL	Aluminum	Sold Separately
	PT-BUL1-BK-LED-3FL	Aluminum	MR16 Included: 3W, 38°, 2700K, 250 Lumens
● Antique	PT-BUL1-BS-NL	Brass	Sold Separately
	PT-BUL1-BS-LED-3FL	Brass	MR16 Included: 3W, 38°, 2700K, 250 Lumens

## SPECIFICATIONS

**CONSTRUCTION:**

- Aluminum or Brass Housing
- Adjustable Knuckle with Locking Teeth for Easy Aiming
- EPDM Rubber Plug in Base
- Dual Silicone O-Rings for Watertight Seal

**LENS:**

- Impact-Resistant Tempered Glass

**LAMP:**

- If Product Code Contains "LED-3FL" Includes Pro-Trade 3W, 38°, 2700K MR16 LED Lamp
- If Product Code Contains "NL" No Lamp Included
- 50W Max

**POWER:**

- Input Voltage 10-18V

**SOCKET:**

- High-Temperature Ceramic
- GU5.3 Bi-Pin with Nickel Contacts
- Heat-Resistant Leads

**MOUNT:**

- Includes ABS Slotted Ground Stake

**WIRING:**

- Pre-Wired with Three Ft. SPT-2W Lead Wire

**WARRANTY:**

- (Free from Material Defects and/or Workmanship)
- Brass: Lifetime
  - Aluminum: Five Years

**CERTIFICATIONS:**

- ETL Listed to UL Standard 1838 and CAN/CSA-22.2 No. 250.7

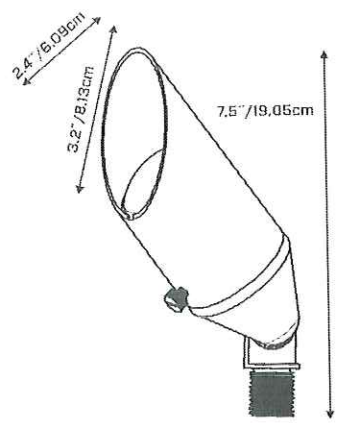

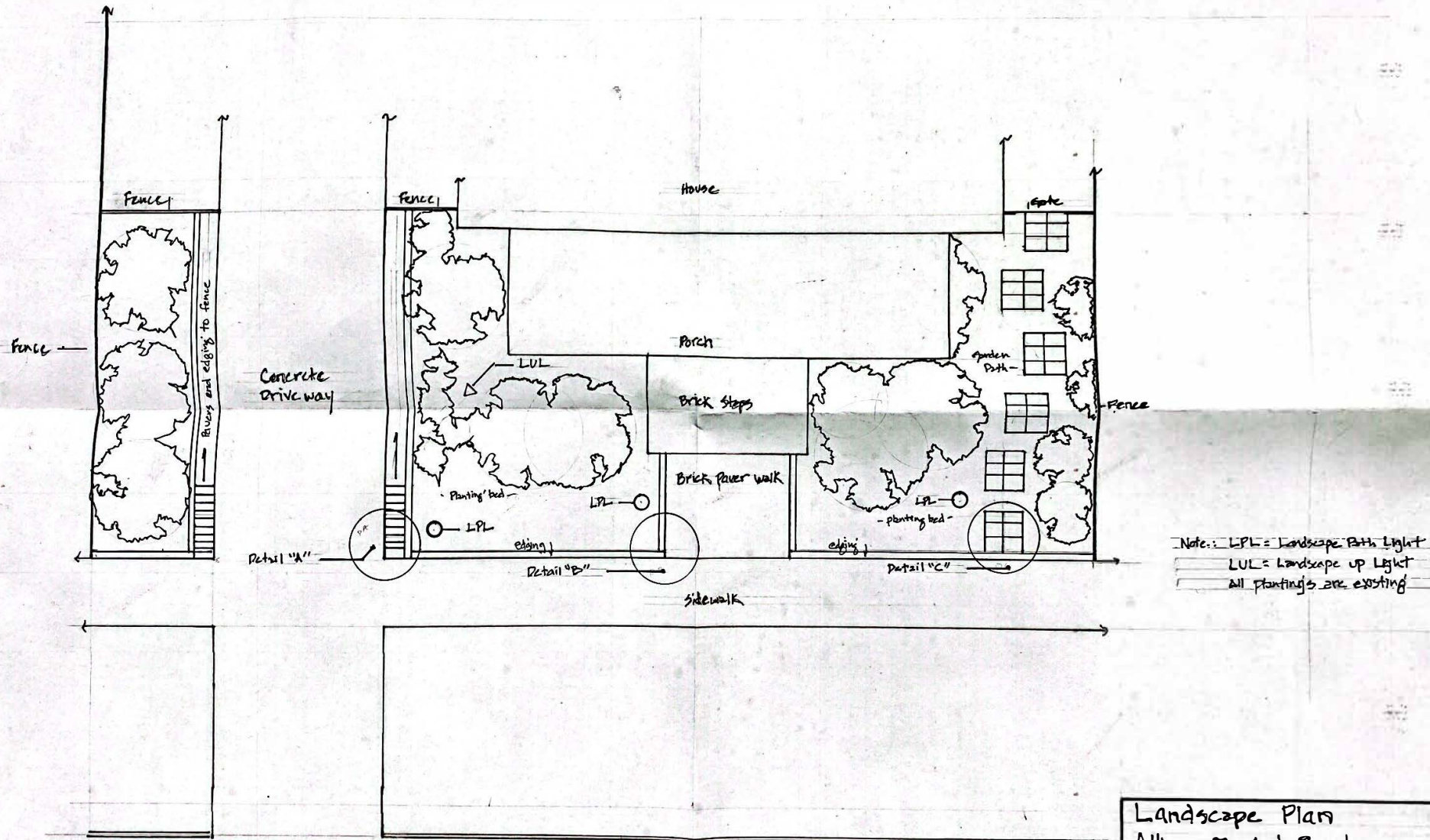

Orange Street

**Landscape Plan**  
 Allison Daniel Residence  
 211 Orange Street - Beaufort, NC  
 Date: 10/22/22 Scale: 1/4" = 1'-0" 20516  
 Scope of Plan: Front  
 Drawn By: Shawn M. Szama  
 American Landscapes NCLC # 0399  
 01060



**Town of Beaufort, NC**

701 Front St. - P.O. Box 390 - Beaufort, N.C. 28516  
252-728-2141 - 252-728-3982 fax - www.beaufortnc.org

**Town of Beaufort Historic Preservation Commission Regular Meeting  
6:00 PM Tuesday, January 3, 2023 – 614 Broad Street – Train Depot**

---

**AGENDA CATEGORY:** New Business  
**SUBJECT:** Case # 22-34 201 Front Street – Fence

**BRIEF SUMMARY:**

The applicant wishes to move the existing Beaufort style fence along the Moore Street side retaining the size, height, picket style and color of existing fence.

**REQUESTED ACTION:**

Conduct Quasi- Judicial Hearing

**EXPECTED LENGTH OF PRESENTATION:**

15 Minutes

**SUBMITTED BY:**

Kyle Garner

**BUDGET AMENDMENT REQUIRED:**

N/A



# BHPC STAFF REPORT



**To:** BHPC Members  
**From:** Kyle Garner, Planning Director  
**Date:** December 20, 2022  
**Case No.** 22-34

---

**Request:** To move the existing Beaufort style fence along the Moore Street side retaining the size, height, picket style and color of existing fence.

**Applicant:** Annette Williamson  
 52 Village Lake Road  
 Fort Worth, TX 76107

**Property Information:**

**Owners:** Same  
**Location:** 201 Front Street  
**PIN#:** 730617005689000

**Project Information:** 1996 - COA was granted for a new 10x20 in rear of property  
 1998 – COA was granted to remove 1-story addition and replace with new 2-story addition on rear of structure.  
 2000 – COA was granted to replace all non-original windows with vinyl clad windows in same style and design and construct a carport over driveway in rear of lot.  
 2014 - A COA was granted to re-roof the main house and accessory structure from fiberglass shingles to Cedar shake and add an addition to the accessory structure.

**Proposed work:**

- See Attachment from Applicant

**Material:**

- See Information from Applicant.

---

**Color:**

See Attached Description from Applicant.

**Attachments:**

- Vicinity Map
- List of adjacent property owners used for mailing notifications
- COA application and supporting materials supplied by applicant.

## Fences and Walls Guidelines

8.2.1. and preserve historic fence and wall material wherever possible. If replacement is necessary, use new material that matches the historic material in composition, size, shape, color, pattern, and texture.

8.2.2. Design new fences that are compatible with the associated building, site and streetscape in height, proportion, scale, color, texture, material, and design. Substitute fence materials are not allowed along front or visible side property lines in the historic district. Fence types such as wire, hurricane, chain-link, vinyl, corrugated metal, stockade, and wooden post and rail are not allowed in public view.

8.2.3. Fences shall not exceed a height of four (4) feet in front yards and other areas of primary visual concern. Fences at rear yards and other areas not readily seen from the public view may be up to six (6) feet high. The transition between low front fences and higher rear fences should be made as far to the rear of the enclosed structure or yard as possible, and no more than half the depth of the yard forward of the principal structure. Avoid attaching a portion of the fence to a building because of possible termite damage.

BHPC Case 22-34 201 Front Street - Fence (Moore Street Side)



<u>OWNER</u>	<u>MAIL_HOL</u>	<u>MAIL_ST</u>	<u>MAIL_CITY</u>	<u>MAIL_ST/MAIL_ZI</u>	<u>MAIL_ADD2</u>
ADAMS,JUDITH E ET VIR ETAL			BEAUFORT	NC 28516	PO BOX 1057
POST,CHARLOTTE	108	MOORE STREET	BEAUFORT	NC 28516	
WILLIAMSON,ANNETT L TR	52	VALLAGE RIDGE ROAD	FORT WORTH	TX 76107	
WILDER,WILLIAM N SR ET UX TANIS	552	LAKELAND DRIVE	KINSTON	NC 28504	

### CERTIFICATE OF APPROPRIATENESS APPLICATION FOR PROJECTS WITHIN THE BEAUFORT HISTORIC DISTRICT



**Instructions:**

Please complete the application below and include all attachments as noted on page 2 of this application along with a **\$250.00 application fee** and return to the Beaufort Town Hall; 701 Front Street or P.O. Box 390, Beaufort, N.C. 28516. Incomplete applications will not be processed and **will be** returned to the applicant. Please contact Town Hall at 252-728-2142 if there are any questions.

**APPLICANT/OWNER INFORMATION**

*Please print!*

Applicant Name: Trevor Harris

Applicant Address: 123 Pleasant Nook Road, Swansboro NC 28584

Business Phone: (910) 650-6633 Email/Cell: tharris@whiteoakfence.com

Property Owner Name: Annette Williamson

Address of Property: 201 Front Street, Beaufort NC 28516

Phone Number: (817) 917-6588 Email/Cell: annette.williamson.farm@gmail.com

**PROJECT INFORMATION**

Detailed description of the Proposed Project (please attach additional pages if necessary):

*Extending & matching the existing fence at 201 Front Street. It will be treated wood material and painted the color white. It will be approx. 36" H. No gates will be added. The total length of the fence is 63'.*

Estimated Cost of Project: \$ N/A

Year House Built: 1790

Trevor Harris  
Applicant Signature

11/21/2022  
Date

Annette Williamson  
Property Owner Signature (if different than above)

11/22/2022  
Date

*An application fee of \$250.00, either in cash, money order, or check made payable to the "Town of Beaufort" must accompany this application (a credit or debit card payment can be made in person at Town Hall). The complete application, payment, and supporting material must be received by Town Staff by the posted submittal dates noted on the Historic Preservation's calendar found on the Town's website at [www.beaufortnc.org](http://www.beaufortnc.org). The Commission meets regularly on the first Tuesday of the month unless it is a holiday.*

**OFFICE USE ONLY**

Received by: \_\_\_\_\_

Reviewed for Completeness: \_\_\_\_\_

Date: \_\_\_\_\_

Date Deemed Completed and Accepted: \_\_\_\_\_

## REQUIRED ATTACHMENTS FOR A CERTIFICATE OF APPROPRIATENESS (COA)

*Please provide the following along with this checklist form, with the COA application:*

### 1. Items required for ALL projects:

- A list all adjacent property owners (with mailing addresses).
- Photographs of the streetscape, the site, and existing buildings to be impacted.
- A site plan showing dimensions of both existing and proposed conditions.
- A description of all building and/or landscaping materials (such as siding, roofing, windows, doors, signs, planting materials, etc.).

### 2. Items required as applicable to project:

- A description of any planned demolition.
- An indication of all trees to be replaced and/or removed.
- A landscaping plan indicating major planting materials.
- Exterior paint color sample/color swatch(s) for projects involving any change of exterior paint color(s) only.
- All types of building material samples.
- If a project involves the reconstruction of an earlier feature of a historic structure, documentation of the prior existence of such feature.

### 3. Additional items required (only) for new Signage:

- A drawing or true likeness of the new sign indicating the dimensions of the sign (and any supporting post or hanging apparatus if applicable). The lettering style and colors of the sign should also be on the drawing or likeness.
- A paint sample/color swatch of all color(s) to be used both on the sign and on the post or hanging apparatus if applicable.

4. At least **one set of materials, in color**, that are to be evaluated by the Commission should be submitted with the application. An electronic or digital file of the work should also be submitted. Please contact Town Staff to see what electronic or digital file can be submitted.

5. The applicant or a representative for the applicant **must be present at the meeting** for action to be taken on the application. If it is not possible for the applicant or their representative to be present at the assigned meeting, please contact Town Staff as soon as possible.

*A COA is valid for a period of six (6) months and may be renewed for an additional six months via written request to Town Staff from the applicant (please state all reasons why the extension is needed). If work has not begun or a [building permit](#) for the project has not been obtained within the six-month period, the COA is deemed invalid. The COA is considered issued once the Commission approves the application at their meeting.*

*If there are questions regarding what should or should not be included with this application, please contact Town Staff at 252-728-2142 or at [k.garner@beaufortnc.org](mailto:k.garner@beaufortnc.org).*



*Picture to the left is of the existing fence located at 201 Front Street, Beaufort.*



*Picture to the right is the location of the new fence line.*

# 201 FROWI ST.

Painted Picket Fence 30" (H) 1 1/2" cap  
Painted white

QTY	DESCRIPTION
7	4" x 4" x 8' Trapped Post
250	1 1/2" x 1 1/2" x 30" Painted Picket Trapped
8	2" x 4" x 16' Trapped

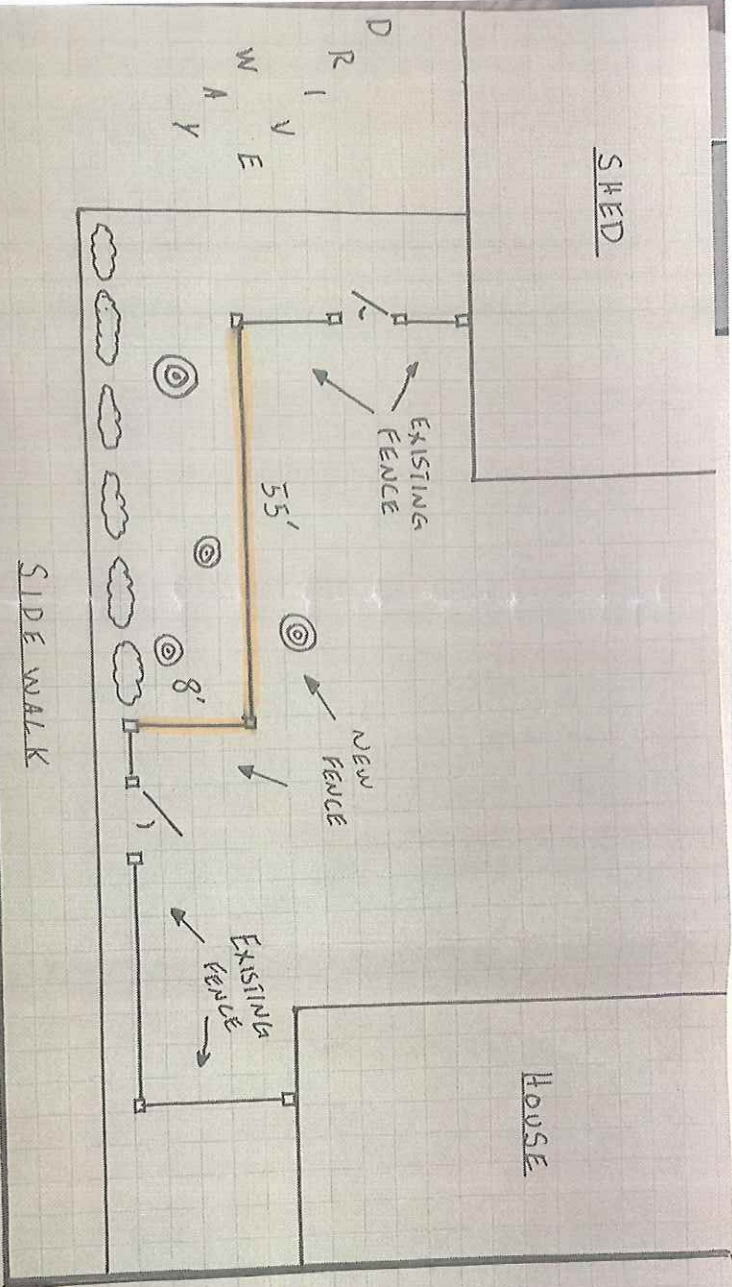

☁ = Hedge

⊙ = Large Tree



**Town of Beaufort, NC**

701 Front St. - P.O. Box 390 - Beaufort, N.C. 28516  
252-728-2141 - 252-728-3982 fax - www.beaufortnc.org

**Town of Beaufort Historic Preservation Commission Regular Meeting  
6:00 PM Tuesday, February 7, 2023 – 614 Broad Street – Train Depot**

---

**AGENDA CATEGORY:** New Business  
**SUBJECT:** Case # 22-16 121 Turner Street – Signage

**BRIEF SUMMARY:**  
The applicant wishes to install a new 16 sq. ft. sign above the door at 121 Turner Street.

**REQUESTED ACTION:**  
Conduct Quasi- Judicial Hearing

**EXPECTED LENGTH OF PRESENTATION:**  
15 Minutes

**SUBMITTED BY:**  
Kyle Garner

**BUDGET AMENDMENT REQUIRED:**  
N/A



# BHPC STAFF REPORT



**To:** BHPC Members  
**From:** Kyle Garner, Planning Director  
**Date:** January 5, 2023  
**Case No.** 22-25

**Request:** Install a new 4’ x 4’ sign over the door totaling 16 square feet.

**Applicant:** Charles Kemp/Sub Tropics  
 1711 Evans Street  
 Morehead City, NC 28557

**Property Information:**

**Owners:** Brenda Chadwick, Trustee  
**Location:** 121 Turner Street  
**PIN#:** 730617102392000

**Project Information:** According to The Beaufort National Register Historic District Comprehensive Survey by M. Ruth Little, Ph.D. of 1997: 121 Turner Street, circa 1908. **Post Office & Custom House.** Two-story, front gable, Neoclassical commercial building, 3bays wide, of redbrick with a buff brick façade, parapeted roof pediment, brick corbelling, arched central window with keystone, 4/4 on façade, 2/2 sash with segmentally arched lintels on sides. 2 recessed entrances flanked by Doric pilasters, with central picture window.

- In 2006 a COA was approved for a 26” x 26” (4.69 sq. ft) sign above the door at 121 Turner Street.
- In 1998 a COA was approved for a roof with charcoal shingles
- In 1994 a COA was approved for a projecting sign from the second story.
- In 1997 a COA was approved to replace the windows with vinyl clad windows.

**Proposed work:**

- See Attachment from Applicant

**Material:**

- See Material Submitted by Applicant

---

**Color:**

See Attached Description from Applicant.

**Attachments:**

- Vicinity Map
- List of adjacent property owners used for mailing notifications
- COA application and supporting materials supplied by applicant to include photos

**Signage Guidelines:**

- 8.6.1. Use traditional materials found in the district, such as wood and metal for new signage. Substitute materials that have the appearance of wood are allowed. Plastic signs, flashing signs, or portable mobile signs, except those listed in item 9, are not allowed in the historic district. Interior neon signs larger than 10” by 18” that are located within five (5) feet of a window or glass door on an exterior wall and are so placed as to be seen from the outside are not allowed. INTERNAL GLASS MOUNTED SIGNS ARE NOT SUBJECT TO BHPC REVIEW. ***Applicant will provide sample material at the meeting.***
- 8.6.2. Place signs so that they do not visually overwhelm the building or streetscape or damage or obscure character defining architectural details. Recognize that maximum signage allowances granted by the Beaufort Zoning Ordinance may be inappropriate in the context of the building or site under review.
- 8.6.3. Signs on commercial buildings are preferred to be located in a signboard frieze located above the display windows. In this location the sign serves as a boundary between the upper and lower façade.
- 8.6.5. Use simple, clear graphics and lettering styles in sign design.

# BHPC Case 22-16 121Turner Street - Signage

**Legend**

- NCHPOpoints
- Tax\_Parcel\_Data



50 25 0 50 Feet

65

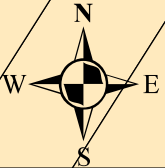

<u>OWNER</u>	<u>MAIL HOL</u>	<u>MAIL ST</u>	<u>MAIL CITY</u>	<u>MAIL ST/MAIL ZIPS</u>
ALDERON CORPORATION	120	TURNER ST	BEAUFORT	NC 28516
BEAUFORT CENTER ASSOCIATES INC	325	FRONT STREET	BEAUFORT	NC 28516
BEAUFORT HISTORICAL ASSOCIATIO	150	TURNER STREET	BEAUFORT	NC 28516
CHADWICK,BRENDA BOWEN TR ETAL	106	GALLANTS LANE	BEAUFORT	NC 28516
CHADWICK,BRENDA BOWEN TRUSTEE	106	GALLANTS LANE	BEAUFORT	NC 28516
FLYBRIDGE VENTURES LLC	5309	SENSATION WEIGH	BEAUFORT	NC 28516

**CERTIFICATE OF APPROPRIATENESS APPLICATION  
FOR PROJECTS WITHIN THE BEAUFORT HISTORIC DISTRICT**



**Instructions:**

Please complete the application below and include all attachments as noted on page 2 of this application along with a **\$50.00 application fee** and return to the Beaufort Town Hall; 701 Front Street or P.O. Box 390, Beaufort, N.C. 28516. Incomplete applications will not be processed and **will be** returned to the applicant. Please contact Town Hall at 252-728-2142 if there are any questions.

**APPLICANT/OWNER INFORMATION**

Please print!

Applicant Name: CHARLES KEMP / SUB TROPICS

Applicant Address: 1711 EVANS ST. MHC. NC 28557

Business Phone: \_\_\_\_\_ Email/Cell: 252-725-0590

Property Owner Name: RICH CHADWICK

Address of Property: 121 TURNER ST

Phone Number: N/A Email/Cell: \_\_\_\_\_

**PROJECT INFORMATION**

Detailed description of the Proposed Project (please attach additional pages if necessary):

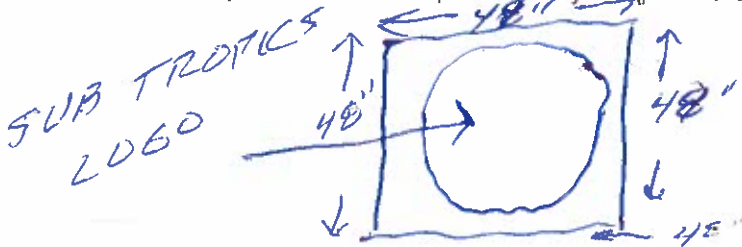

Estimated Cost of Project: \$ 500.00

Year House Built: \_\_\_\_\_

Applicant Signature: Charles Kemp

Date: 4-29-22

Property Owner Signature (if different than above) \_\_\_\_\_

Date \_\_\_\_\_

*An application fee of \$50.00, either in cash, money order, or check made payable to the "Town of Beaufort" must accompany this application (a credit or debit card payment can be made in person at Town Hall). The complete application, payment, and supporting material must be received by Town Staff by the posted submittal dates noted on the Historic Preservation's calendar found on the Town's website at [www.beaufortnc.org](http://www.beaufortnc.org). The Commission meets regularly on the first Tuesday of the month unless it is a holiday.*

**OFFICE USE ONLY**

Received by: \_\_\_\_\_

Reviewed for Completeness: \_\_\_\_\_

Date: \_\_\_\_\_

Date Deemed Completed and Accepted: \_\_\_\_\_

**REQUIRED ATTACHMENTS FOR A CERTIFICATE OF APPROPRIATENESS (COA)**

*Please provide the following along with this checklist form, with the COA application:*

**1. Items required for ALL projects:**

- A list all adjacent property owners (with mailing addresses).
- Photographs of the streetscape, the site, and existing buildings to be impacted.
- A site plan showing dimensions of both existing and proposed conditions.
- A description of all building and/or landscaping materials (such as siding, roofing, windows, doors, signs, planting materials, etc.).

**2. Items required as applicable to project:**

- A description of any planned demolition.
- An indication of all trees to be replaced and/or removed.
- A landscaping plan indicating major planting materials.
- Exterior paint color sample/color swatch(s) for projects involving any change of exterior paint color(s) only.
- All types of building material samples.
- If a project involves the reconstruction of an earlier feature of a historic structure, documentation of the prior existence of such feature.

**3. Additional items required (only) for new Signage:**

- A drawing or true likeness of the new sign indicating the dimensions of the sign (and any supporting post or hanging apparatus if applicable). The lettering style and colors of the sign should also be on the drawing or likeness.
- A paint sample/color swatch of all color(s) to be used both on the sign and on the post or hanging apparatus if applicable.

**4. At least one set of materials, in color, that are to be evaluated by the Commission should be submitted with the application. An electronic or digital file of the work should also be submitted. Please contact Town Staff to see what electronic or digital file can be submitted.**

**5. The applicant or a representative for the applicant must be present at the meeting for action to be taken on the application. If it is not possible for the applicant or their representative to be present at the assigned meeting, please contact Town Staff as soon as possible.**

*A COA is valid for a period of six (6) months and may be renewed for an additional six months via written request to Town Staff from the applicant (please state all reasons why the extension is needed). If work has not begun or a building permit for the project has not been obtained within the six-month period, the COA is deemed invalid. The COA is considered issued once the Commission approves the application at their meeting.*

*If there are questions regarding what should or should not be included with this application, please contact Town Staff at 252-728-2142 or at [j.ganey@beaufortnc.org](mailto:j.ganey@beaufortnc.org).*









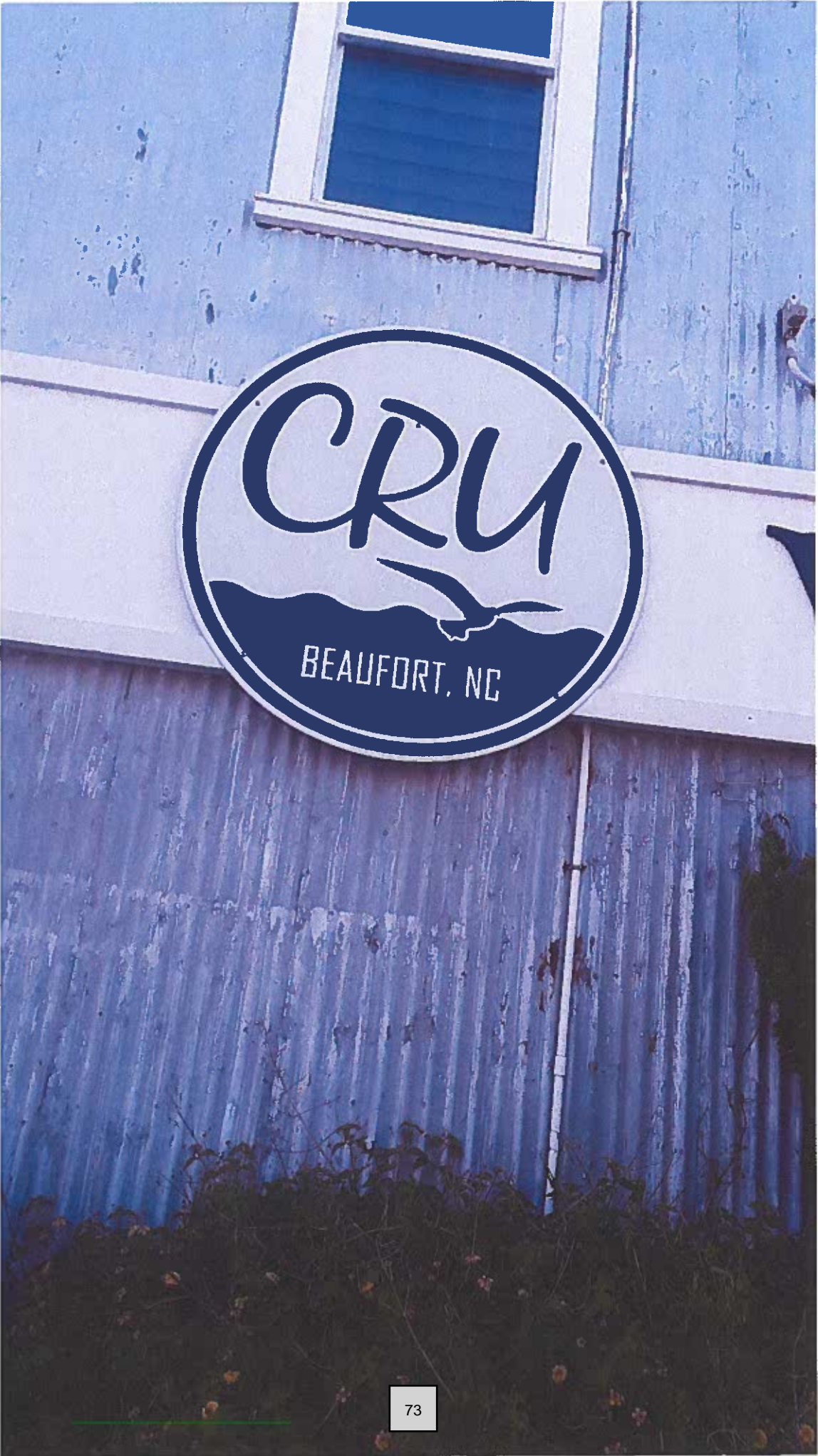



**Town of Beaufort, NC**

701 Front St. - P.O. Box 390 - Beaufort, N.C. 28516  
252-728-2141 - 252-728-3982 fax - www.beaufortnc.org

**Town of Beaufort Historic Preservation Commission Regular Meeting  
6:00 PM Tuesday, February 7, 2023 – 614 Broad Street – Train Depot**

---

**AGENDA CATEGORY:** New Business  
**SUBJECT:** Case # 23-01 521 Front Street - Signage

**BRIEF SUMMARY:**

The applicant wishes to install a 20 sq. ft. metal sign to replace the existing sign on the awning.

**REQUESTED ACTION:**

Conduct Quasi- Judicial Hearing

**EXPECTED LENGTH OF PRESENTATION:**

15 Minutes

**SUBMITTED BY:**

Kyle Garner

**BUDGET AMENDMENT REQUIRED:**

N/A



# BHPC STAFF REPORT



**To:** BHPC Members  
**From:** Kyle Garner, Planning Director  
**Date:** January 12, 2023  
**Case No.** 23-01

**Request:** To install a 20 sq. ft. metal sign to replace the existing sign on the awning.

**Applicant:** Andrea Alvarez/Mexcalito  
 521 Front Street  
 Beaufort, NC 28516

**Property Information:**

**Owners:** Plaza Mexico Bar & Grill Inc.  
**Location:** 510 Front Street  
**PIN#:** 730505198871000

**Project Information:** In the District Survey (November 1997), updated by Ruth Little, the Building at 521 Front Street is described as a **Commercial Building** c. 1960. 1-story brick building with flat roof and recessed glass and metal storefront. Virtually no façade ornamentation.

In March 2019 a COA was granted for a new awning with **22** sq. ft. of signage.

In February 2012 a COA was granted for a new awning with **44** sq. ft. of signage within the awning.

In May 2005 a COA was approved for a plain black awning, signage and improvements to the rear. The applicant also stated that they were not asking to paint the brick.

In August 1996 a COA was granted for a 15 sq. ft. exterior sign.

**Proposed work:**

- See Attachment from Applicant

**Material:**

- See Information from Applicant.

---

**Color:**

See Attached Description from Applicant.

**Attachments:**

- Vicinity Map
- List of adjacent property owners used for mailing notifications
- COA application and supporting materials supplied by applicant.

**There is 32 feet of street frontage which would allow for 64 total square feet of signage for the building.**

**Signage Guidelines:**

8.6.1. Use traditional materials found in the district, such as wood and metal for new signage. Substitute materials that have the appearance of wood are allowed. Plastic signs, flashing signs, or portable mobile signs, except those listed in item 9, are not allowed in the historic district. Interior neon signs larger than 10” by 18” that are located within five (5) feet of a window or glass door on an exterior wall and are so placed as to be seen from the outside are not allowed. INTERNAL GLASS MOUNTED SIGNS ARE NOT SUBJECT TO BHPC REVIEW.

8.6.2. Place signs so that they do not visually overwhelm the building or streetscape or damage or obscure character defining architectural details. Recognize that maximum signage allowances granted by the Beaufort Zoning Ordinance may be inappropriate in the context of the building or site under review.

8.6.3. Signs on commercial buildings are preferred to be located in a signboard frieze located above the display windows. In this location the sign serves as a boundary between the upper and lower façade.

8.6.5. Use simple, clear graphics and lettering styles in sign design.

# BHPC Case 23-01 521 Front Street - Signage



<u>OWNER</u>	<u>MAIL_HOU</u>	<u>MAIL_ST</u>	<u>MAIL_CITY</u>	<u>IL_ST</u>	<u>MAIL_ZI</u>	<u>MAIL_ADD2</u>
BEAUFORT HOUSE LLC	510	FRONT STREET #21	BEAUFORT	NC	28516	
LAWVER ENTERPRISES LLC	4643	RANDOLPH CHURCH ROAD	LIBERTY	NC	27298	
PLAZA MEXICO BAR & GRILL INC	5167	HIGHWAY 70 WEST #60	MOREHEAD CITY	NC	28557	
SMITH, ANNE HILL ETAL GORDON	1205	FRONT STREET	BEAUFORT	NC	28516	
TOWN OF BEAUFORT			BEAUFORT	NC	28516	PO BOX 390

# CERTIFICATE OF APPROPRIATENESS APPLICATION FOR PROJECTS WITHIN THE BEAUFORT HISTORIC DISTRICT



### Instructions:

Please complete the application below and include all attachments as noted on page 2 of this application along with a **\$250.00 application fee** and return to the Beaufort Town Hall; 701 Front Street or P.O. Box 390, Beaufort, N.C. 28516. Incomplete applications will not be processed and **will be** returned to the applicant. Please contact Town Hall at 252-728-2142 if there are any questions.

### APPLICANT/OWNER INFORMATION

Please print!

Applicant Name: Andrea Alvarez

Applicant Address: \_\_\_\_\_

Business Phone: 252-728-3702 Email/Cell: metcalito2021playa@gmail.com

Property Owner Name: Jose A Alvarez

Address of Property: 521 Front St

Phone Number: 252-269-0087 Email/Cell: \_\_\_\_\_

### PROJECT INFORMATION

Detailed description of the Proposed Project (please attach additional pages if necessary):

Change the peeled and discolored metcalito lettering in black awning to an aluminum panel with the metcalito sign

Price: \$350  
Installation: \$125/hr

Estimated Cost of Project: \$ \_\_\_\_\_

Year House Built: \_\_\_\_\_

Andrea Alvarez  
Applicant Signature

12-16-22  
Date

Jose A. Alvarez  
Property Owner Signature (if different than above)

12-16-22  
Date

An application fee of \$250.00, either in cash, money order, or check made payable to the "Town of Beaufort" must accompany this application (a credit or debit card payment can be made in person at Town Hall). The complete application, payment, and supporting material must be received by Town Staff by the posted submittal dates noted on the Historic Preservation's calendar found on the Town's website at [www.beaufortnc.org](http://www.beaufortnc.org). The Commission meets regularly on the first Tuesday of the month unless it is a holiday.

### OFFICE USE ONLY

Received by: \_\_\_\_\_

Reviewed for Completeness: \_\_\_\_\_

Date: \_\_\_\_\_

Date Deemed Completed and Accepted: \_\_\_\_\_

**REQUIRED ATTACHMENTS FOR A CERTIFICATE OF APPROPRIATENESS (COA)**

*Please provide the following along with this checklist form, with the COA application:*

**1. Items required for ALL projects:**

- A list all adjacent property owners (with mailing addresses).
- Photographs of the streetscape, the site, and existing buildings to be impacted.
- A site plan showing dimensions of both existing and proposed conditions.
- A description of all building and/or landscaping materials (such as siding, roofing, windows, doors, signs, planting materials, etc.).

**2. Items required as applicable to project:**

- A description of any planned demolition.
- An indication of all trees to be replaced and/or removed.
- A landscaping plan indicating major planting materials.
- Exterior paint color sample/color swatch(s) for projects involving any change of exterior paint color(s) only.
- All types of building material samples.
- If a project involves the reconstruction of an earlier feature of a historic structure, documentation of the prior existence of such feature.

**3. Additional items required (only) for new Signage:**

- A drawing or true likeness of the new sign indicating the dimensions of the sign (and any supporting post or hanging apparatus if applicable). The lettering style and colors of the sign should also be on the drawing or likeness.
- A paint sample/color swatch of all color(s) to be used both on the sign and on the post or hanging apparatus if applicable.

**4. At least one set of materials, in color,** that are to be evaluated by the Commission should be submitted with the application. An electronic or digital file of the work should also be submitted. Please contact Town Staff to see what electronic or digital file can be submitted.

**5. The applicant or a representative for the applicant must be present at the meeting** for action to be taken on the application. If it is not possible for the applicant or their representative to be present at the assigned meeting, please contact Town Staff as soon as possible.

*A COA is valid for a period of six (6) months and may be renewed for an additional six months via written request to Town Staff from the applicant (please state all reasons why the extension is needed). If work has not begun or a building permit for the project has not been obtained within the six-month period, the COA is deemed invalid. The COA is considered issued once the Commission approves the application at their meeting.*

*If there are questions regarding what should or should not be included with this application, please contact Town Staff at 252-728-2142 or at [k.garner@beaufortnc.org](mailto:k.garner@beaufortnc.org).*

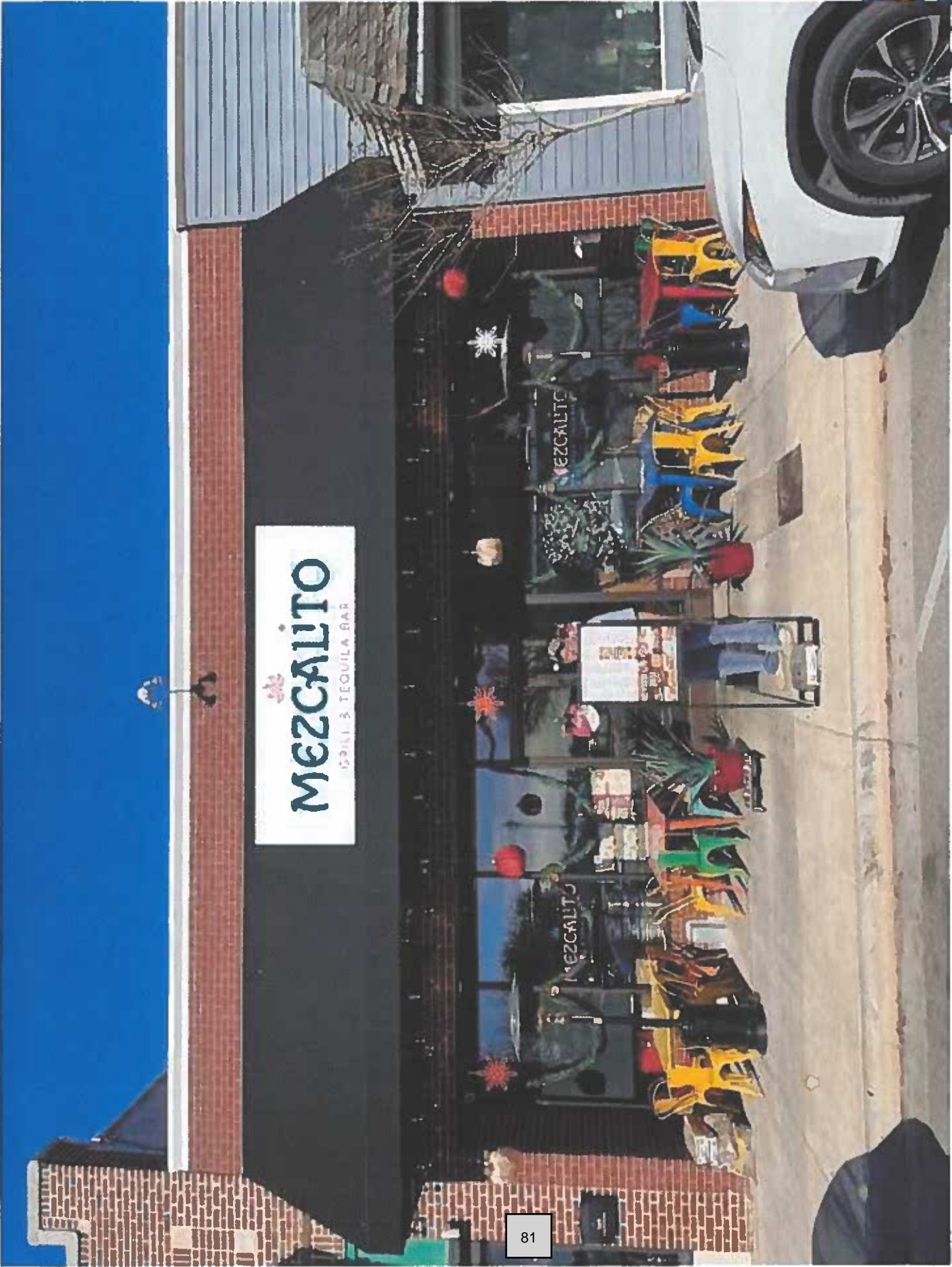

81

Qty-1 30" x 96" Aluminum Single Sided

4.

SWING 252. Live Oak St. Bea



**Town of Beaufort, NC**

701 Front St. - P.O. Box 390 - Beaufort, N.C. 28516  
252-728-2141 - 252-728-3982 fax - www.beaufortnc.org

**Town of Beaufort Historic Preservation Commission Regular Meeting  
6:00 PM Tuesday, February 7, 2023 – 614 Broad Street – Train Depot**

---

**AGENDA CATEGORY:** New Business  
**SUBJECT:** Case # 23-02 300 Front Street Unit 3 - New Sign

**BRIEF SUMMARY:**

The applicant wishes to install a Hanging Sign = 10.6 sq. ft., an Attached Sign on the East Side of Building = 16 sq. ft. & an Above Window Sign = 5 sq. ft. Totaling = 31.6 sq. ft

**REQUESTED ACTION:**

Conduct Quasi- Judicial Hearing

**EXPECTED LENGTH OF PRESENTATION:**

15 Minutes

**SUBMITTED BY:**

Kyle Garner

**BUDGET AMENDMENT REQUIRED:**

N/A



# BHPC STAFF REPORT



**To:** BHPC Members  
**From:** Kyle Garner, Planning Director  
**Date:** January 19, 2023  
**Case No.:** 23-02

**Request:** Hanging Signage = 10.6 sq. ft., Attached Signage on East Side of Building = 16 sq. ft. & Above window = 5 sq. ft. Total = 31.6 sq. ft.

**Applicant:** Michele Zeph  
 2006 Shepard Street

**Property Information:**

**Owner:** John Warrington  
**Location:** 300 Front Street  
**PIN:** 730617008242000

**Project Information:**

According to The Beaufort National Register Historic District Comprehensive Survey by M. Ruth Little, Ph.D. of 1997: 300 Front Street, C, circa 1985 **Commercial Building**. Large 1-Story Mitchell Manufactured prefabricated metal building with a white brick façade.

The proposed signage is to replace the Beaufort Olive Oil Business hanging sign (6.9 sq. ft) as well as the attached window sign of 6.9 sq. ft.

This property has 85 feet of street frontage which would permit up to 170 square feet of total signage per the Land Development Ordinance (LDO) So far Front Street Taco (COA 2022) has 30.63 sq. ft and Beaufort Yacht Sales has 28 sq. ft. So far total signage is 58.63 sq. ft of the 170 allowed.

---

**Material:** Metal – Per Sample in Planning Office

**Color:** See Attached Application

**Attachments:**

- Vicinity Map
- List of Adjacent Property Owners
- COA Application from Applicant.

**Guidelines:**

**Signage Guidelines (pg. 119):**

- 8.6.1. Use traditional materials found in the district, such as wood and metal for new signage. Substitute materials that have the appearance of wood are allowed. Plastic signs, flashing signs, or portable mobile signs, except those listed in item 9, are not allowed in the historic district. Interior neon signs larger than 10” by 18” that are located within five (5) feet of a window or glass door on an exterior wall and are so placed as to be seen from the outside are not allowed. INTERNAL GLASS MOUNTED SIGNS ARE NOT SUBJECT TO BHPC REVIEW.
- 8.6.2. Place signs so that they do not visually overwhelm the building or streetscape or damage or obscure character defining architectural details. Recognize that maximum signage allowances granted by the Beaufort Zoning Ordinance may be inappropriate in the context of the building or site under review.
- 8.6.3. Signs on commercial buildings are preferred to be located in a signboard frieze located above the display windows. In this location the sign serves as a boundary between the upper and lower façade.
- 8.6.5. Use simple, clear graphics and lettering styles in sign design.

BHPC Case 23-02 300 Front Street Unit 3 - Signage

**Legend**

- NCHPOpoints
- Tax\_Parcel\_Data

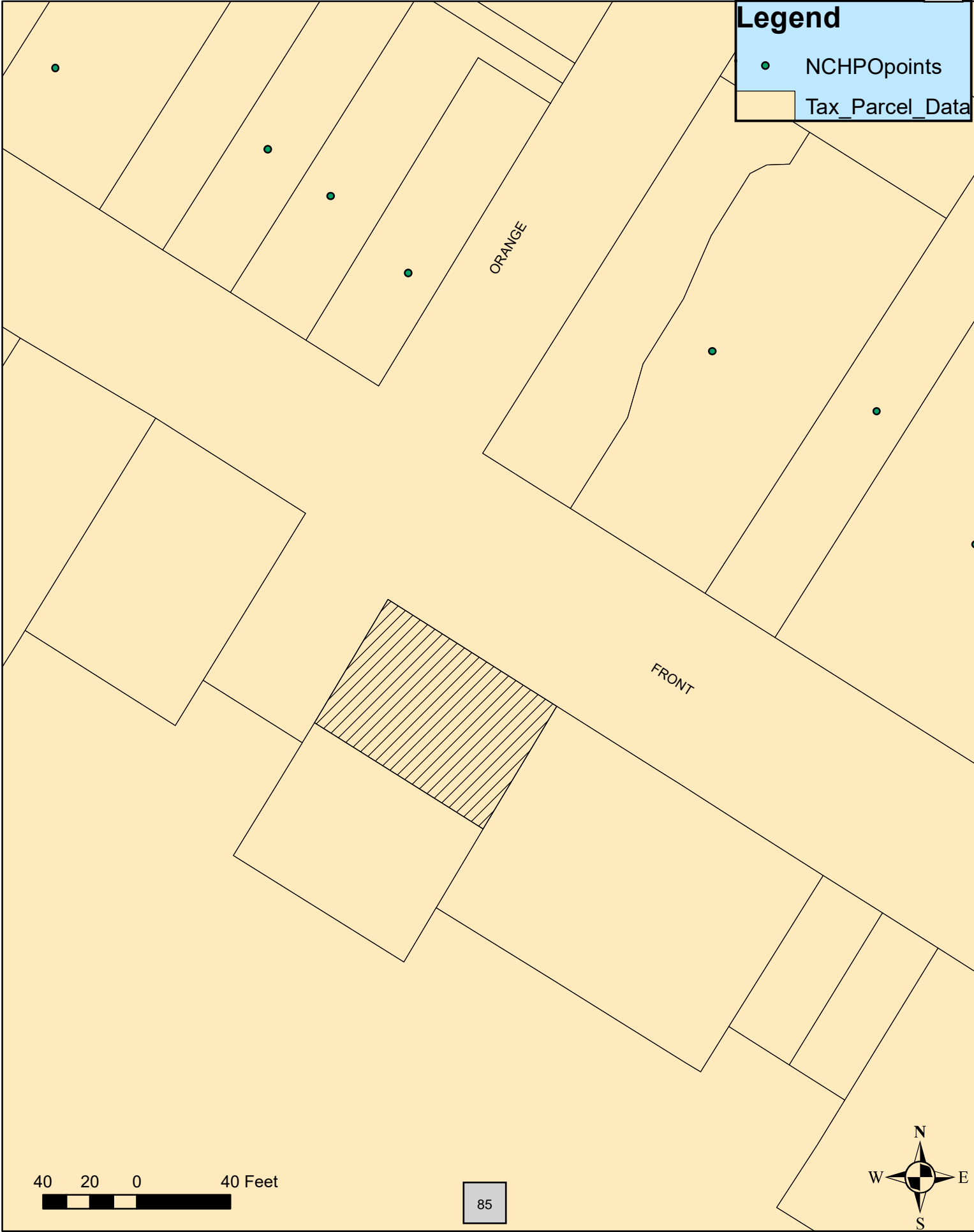

40 20 0 40 Feet

85



<u>OWNER</u>	<u>MAIL_HOL</u>	<u>MAIL_ST</u>	<u>MAIL_CITY</u>	<u>L_ST</u>	<u>MAIL_ZI</u>	<u>MAIL_ZI</u>	<u>MAIL_ADD2</u>
ASCENCIOS,LAUREN ETVIR JULIO FOUR SEAS INVESTMENTS	305	FRONT STREET	BEAUFORT	NC		28516	
HARROLD,DENNIS B ETUX ALICE T J 218 LLC	301	FRONT STREET	BEAUFORT	NC		28516	
REDHAGE,SHARON H	900	ST ANDREWS STREET	TARBORO	NC		27886	
STATE OF NORTH CAROLINA	1321	MAIL SERVICE CENTER	RALEIGH	NC	1321	27699	
WARRINGTON,JOHN ETUX SONDA	300	FRONT ST	BEAUFORT	NC		28516	

### CERTIFICATE OF APPROPRIATENESS APPLICATION FOR PROJECTS WITHIN THE BEAUFORT HISTORIC DISTRICT



#### **Instructions:**

Please complete the application below and include all attachments as noted on page 2 of this application along with a **\$250.00 application fee** and return to the Beaufort Town Hall; 701 Front Street or P.O. Box 390, Beaufort, N.C. 28516. Incomplete applications will not be processed and **will be** returned to the applicant. Please contact Town Hall at 252-728-2142 if there are any questions.

#### **APPLICANT/OWNER INFORMATION**

*Please print!*

Applicant Name: Michelle Zeph

Applicant Address: 2006 Shepard St.

Business Phone: 252-499-4055 Email/Cell: sales@zandzdesigns.com  
252-521-1898

Property Owner Name: John L. Warrington

Address of Property: 300 Front St. Unit 3

Phone Number: 252-728-3155 Email/Cell: bys@beaufortyachtsales.com

#### **PROJECT INFORMATION**

Detailed description of the Proposed Project (please attach additional pages if necessary):

Place 3 signs at site, one on existing bracket in front of Beaufort Olive Oil, the same size as Front St. Taco at other window. The second sign will be on side of building where other business signs are of the same size. The 3rd sign is above the front window.

Estimated Cost of Project: \$610.00

Year House Built: \_\_\_\_\_

Michelle Zeph  
Applicant Signature

11/30/22  
Date

John Warrington  
Property Owner Signature (if different than above)

12/20/2022  
Date

**An application fee of \$250.00, either in cash, money order, or check made payable to the "Town of Beaufort" must accompany this application (a credit or debit card payment can be made in person at Town Hall). The complete application, payment, and supporting material must be received by Town Staff by the posted submittal dates noted on the Historic Preservation's calendar found on the Town's website at [www.beaufortnc.org](http://www.beaufortnc.org). The Commission meets regularly on the first Tuesday of the month unless it is a holiday.**

#### **OFFICE USE ONLY**

Received by: \_\_\_\_\_

Reviewed for Completeness: \_\_\_\_\_

Date: \_\_\_\_\_

Date Deemed Completed and Accepted: \_\_\_\_\_



(x1) storefront hanging sign 32" x 48" double sided ACP  
price: \$325



(x1) storefront sign 10" x 72" ACP  
price: \$135



(x1) East end of building sign 24" x 96" ACP  
price: \$285



(x1) front door sign 12" x 18" ACP  
price: \$45

# BEAUFORT LOCATION

## **REQUIRED ATTACHMENTS FOR A CERTIFICATE OF APPROPRIATENESS (COA)**

*Please provide the following along with this checklist form, with the COA application:*

**1. Items required for ALL projects:**

- A list all adjacent property owners (with mailing addresses).
- Photographs of the streetscape, the site, and existing buildings to be impacted.
- A site plan showing dimensions of both existing and proposed conditions.
- A description of all building and/or landscaping materials (such as siding, roofing, windows, doors, signs, planting materials, etc.).

**2. Items required as applicable to project:**

- A description of any planned demolition.
- An indication of all trees to be replaced and/or removed.
- A landscaping plan indicating major planting materials.
- Exterior paint color sample/color swatch(s) for projects involving any change of exterior paint color(s) only.
- All types of building material samples.
- If a project involves the reconstruction of an earlier feature of a historic structure, documentation of the prior existence of such feature.

**3. Additional items required (only) for new Signage:**

- A drawing or true likeness of the new sign indicating the dimensions of the sign (and any supporting post or hanging apparatus if applicable). The lettering style and colors of the sign should also be on the drawing or likeness.
- A paint sample/color swatch of all color(s) to be used both on the sign and on the post or hanging apparatus if applicable.

**4. At least one set of materials, in color, that are to be evaluated by the Commission should be submitted with the application. An electronic or digital file of the work should also be submitted. Please contact Town Staff to see what electronic or digital file can be submitted.**

**5. The applicant or a representative for the applicant must be present at the meeting for action to be taken on the application. If it is not possible for the applicant or their representative to be present at the assigned meeting, please contact Town Staff as soon as possible.**

*A COA is valid for a period of six (6) months and may be renewed for an additional six months via written request to Town Staff from the applicant (please state all reasons why the extension is needed). If work has not begun or a building permit for the project has not been obtained within the six-month period, the COA is deemed invalid. The COA is considered issued once the Commission approves the application at their meeting.*

*If there are questions regarding what should or should not be included with this application, please contact Town Staff at 252-728-2142 or at [k.garner@beaufortnc.org](mailto:k.garner@beaufortnc.org).*