



City of Arkansas City

CITY COMMISSION MEETING AGENDA

Tuesday, May 03, 2022 at 5:30 PM – 118 W Central Ave, Arkansas City, KS

Please join my meeting from your computer, tablet, or smartphone.

<https://meet.goto.com/995872757>

You can also dial in using your phone.

United States: +1 (646) 749-3122

Access Code: 995-872-757

I. Routine Business

1. Roll Call
2. Opening Prayer and Pledge of Allegiance
3. Additions or Deletions (**Voice Vote**)
4. Approval of the Agenda (**Voice Vote**)

II. Awards and Proclamations

1. Recognize and congratulate Martyna Kowalska, Paul Lyman, and Daniela Salcedo, Arkansas City's Outstanding Student Award scholarship recipients for 2021-2022.
2. Proclaim May 2022 as National Foster Care Month in Arkansas City.
3. Proclaim May 5, 2022 as Cinco De Mayo Day in Arkansas City.
4. Proclaim May 5, 2022, as a Day of Prayer in Arkansas City.
5. Proclaim May 15-21, 2022, as National EMS Week in Arkansas City.
6. Proclaim May 1-8, 2022, as National Music Week in Arkansas City.
7. Proclaim May 6-12, 2022, as National Nurses Week and May 8-14, 2022, as National Hospital Week in Arkansas City.
8. Proclaim May 15-21, 2022, as National Police Week and May 15, 2022, as Peace Officers Memorial Day in Arkansas City.
9. Proclaim May 1-7, 2022 as Public Service Recognition Week in Arkansas City.

III. Comments from the Audience for Items Not on the Agenda

Per the Kansas Open Meetings Act, the City Commission is not required to entertain any comments from the public during any meeting.

*The following rules **must** be strictly adhered to by all citizens wishing to speak during a virtual/hybrid meeting, **whether they are on the agenda or recognized by the Mayor during the meeting itself:***

- Each speaker will state his or her name and address before making any comments.
- Each speaker will have three (3) minutes to present his or her comments.
- Comments or questions will be directed only to the City Commission.
- Debate or argument between parties in the audience will not be allowed. **"Logged in" citizens will remain muted during the meeting, unless recognized and called upon specifically by the Mayor.**
- Repeated reiterations by speakers will not be allowed.
- Violations of comment procedure will result in being directed to cease speaking or being muted.

IV. Consent Agenda (Voice Vote)

Note: All matters listed below on the Consent Agenda are considered under one motion and enacted by one motion. There should be no separate discussion. If such discussion is desired, any item may be removed from the Consent Agenda and then considered separately under Section VII: New Business.

1. Approve the April 19, 2022, regular meeting minutes as written.
2. Ratify Mayor Kanyon Gingher's appointment of Katie Boyle to the Arkansas City Public Library Board of Trustees.

V. New Business

Other Business for Consideration

1. Consider approval of City insurance coverage for property, liability, vehicles, and equipment. **(Voice Vote)**

Resolutions for Consideration

1. Consider a Resolution authorizing the City of Arkansas City to accept a bid submitted by United Rentals, of Park City, KS, to purchase a 6" Super Vac Assist Diesel Pump for the Street/Stormwater Department, for an amount not to exceed \$39,900.00. **(Voice Vote)**

VI. Staff Report Presentations

City Manager's Report on Upcoming Activities

1. Budget Work Session/Commission Retreat
2. To The Stars: Celebrating Kansas Businesses Awards Banquet
3. City Commission Work Session
4. City Commission Meeting
5. City Commission Budget Work Session with Outside Agencies
6. Current City Projects Status Update

VII. Adjournment



City Commission Agenda Item

Meeting Date: May 3, 2022
From: Randy Frazer, City Manager
Item: 2022 Outstanding Student Award Recognitions

Purpose: Recognition Item: Recognize and congratulate Martyna Kowalska, Paul Lyman, and Daniela Salcedo, Arkansas City’s Outstanding Student Award scholarship recipients for 2021-2022.

Background:

The **Outstanding Student Award** program was started in 1984. The City Commission implemented the program to recognize students who are outstanding examples of academic and civic excellence in our community. Each year, staff asks teachers, staff, and administrators at Ark City Christian Academy, Arkansas City Middle School, Arkansas City High School and Cowley College to nominate students they think are qualified for this honor.

Each year, the **Outstanding Student Award Committee**, appointed by the Mayor and City Commission, receives all nominations from the three schools. Short, informal interviews are conducted with each nominee, and the committee then chooses three finalists from each school to represent the nominees.

From the nine (9) finalists, a top student is chosen for each school. One (1) of them is chosen to represent the City of Arkansas City as the Outstanding Student for that year and to receive a **\$1,000** scholarship. The first runner-up now receives a **\$500** scholarship and the second runner-up receives a **\$250** scholarship.

This year’s overall Outstanding Student for Arkansas City is Arkansas City High School student **Daniela Salcedo**. The first runner-up is Arkansas City Middle School student Paul Lyman, while the second runner-up is Cowley County College student Martyna Kowalska.

Commission Options:

1. Introduce Martyna Kowalska and formally award her a \$250 scholarship.
2. Introduce Paul Lyman and formally award him a \$500 scholarship.
3. Introduce Daniela Salcedo and formally award her the 2021-2022 Outstanding Student Award.

Fiscal Impact:

Amount: **\$1,750.00**
Fund: **01** (General) Department: **201** (Commission) Expense Code: **6217** Contributions
 Included in Budget Grant Bonds Other (explain):

Approved for Agenda by:



Randy Frazer, City Manager

Office of the Mayor

Arkansas City, Kansas
Proclamation

WHEREAS, May is National Foster Care Month, a month set aside to acknowledge foster parents, family members, volunteers, mentors, policymakers, child welfare professionals, and other members of the community who help children and youth in foster care to find permanent homes and connections; and

WHEREAS, during National Foster Care Month, the City of Arkansas City renews its commitment to ensuring a bright future for the more than 400,000 children and youth in foster care, and celebrates all of those who make a meaningful difference in their lives; and

WHEREAS, foster families are unsung heroes who serve as the primary source of love, protection, and support to the children and youth in the foster care system in Cowley County; and

WHEREAS, there are numerous individuals, and public and private organizations, who work tirelessly to increase public awareness of the needs of children in foster care, as well as the enduring and valuable contribution of foster parents, and recognize that the foster care system is only as good as those who choose to be a part of it.

NOW, THEREFORE, the Mayor of the City of Arkansas City, Kansas, calls upon all citizens of Arkansas City to observe the month of **May 2022** as

NATIONAL FOSTER CARE MONTH

in Arkansas City and encourage all citizens of the City of Arkansas City to consider extending their family to include fostering some of our most vulnerable children.

In witness whereof I have hereunto set my hand and caused this seal to be affixed.

Name/Title: *Kanyon Gingher, Mayor*
Date: *May 3, 2022*

Office of the Mayor
Arkansas City, Kansas

Proclamation

WHEREAS, every year the date of May 5 is observed to commemorate the Mexican army’s unlikely victory over French forces at the Battle of Puebla on May 5, 1862; and

WHEREAS, originating in the 1860s with Mexican-American communities in the American West, Southwest and Northwest, the American Cinco de Mayo holiday began as a way to commemorate the cause of freedom and democracy during the first years of the Civil War; and

WHEREAS, today in the United States, Cinco de Mayo is observed annually on May 5 as a celebration of Mexican heritage and pride; and

WHEREAS, Cinco de Mayo celebrations in the United States have taken on a significance beyond that in Mexico, including the displaying of banners and events highlighting Mexican culture, music, and regional dancing, as well as school districts holding special events to educate students about its historical significance; and

WHEREAS, the Arkansas City Equal Opportunity and Accessibility Advisory Board — in cooperation with 1025 The River, the Arkansas City Beautification and Tree Advisory Board, the Northwest Community Center Advisory Board, Visit Ark City, and other local sponsors — will be host to the annual Tacolalah Festival on **Saturday, May 7, 2022**, at Wilson Park, featuring dancing, food, games, music, and more from Mexico and several other Latino countries.

NOW, THEREFORE, the Mayor of the City of Arkansas City, Kansas, does hereby proclaim **May 5, 2022**, as

CINCO DE MAYO DAY

in Arkansas City, and encourage all citizens of the City of Arkansas City to observe Cinco de Mayo by participating in the second annual Tacolalah Festival, and other appropriate ceremonies and activities.

In witness thereof I have hereunto set my hand and caused this seal to be affixed:

Name/Title: *Kanyon Gingher, Mayor*
Date: *May 3, 2022*

Office of the Mayor
Arkansas City, Kansas

Proclamation

WHEREAS, the National Day of Prayer is a tradition first proclaimed by the Continental Congress in 1775; and

WHEREAS, the United States Congress, by a joint resolution on April 17, 1952, provided that the President “shall set aside and proclaim a suitable day each year, other than a Sunday, as a National Day of Prayer, on which the people of the United States may turn to God in prayer and meditation”; and

WHEREAS, in 1988, legislation setting aside the first Thursday of May in each year as a National Day of Prayer was passed unanimously by both houses of the United States Congress and signed by President Ronald Reagan; and

WHEREAS, the National Day of Prayer is an opportunity for all Americans to join in united prayer to acknowledge our dependence on God, give thanks for blessings received, request healing for wounds endured, and ask God to guide our leaders and bring wholeness to the United States and its citizens, especially during this trying time of the coronavirus (COVID-19) pandemic; and

WHEREAS, it is fitting and proper to give thanks to God by observing a day of prayer in the City of Arkansas City, Kansas, when all may acknowledge our blessings and express gratitude for them, while recognizing our dependence on God for our continued blessings and guidance.

NOW, THEREFORE, the Mayor of the City of Arkansas City, Kansas, does hereby proclaim **Thursday, May 5, 2022**, as

A DAY OF PRAYER

in Arkansas City, and encourage all citizens of the City of Arkansas City to observe this day in ways appropriate to its importance and significance.

In witness thereof I have hereunto set my hand and caused this seal to be affixed:

 Name/Title: *Kanyon Gingher, Mayor*
 Date: *May 3, 2022*

Office of the Mayor

Arkansas City, Kansas
Proclamation

WHEREAS, emergency medical services are a vital public need, especially in this time of the pandemic; and

WHEREAS, the members of emergency medical services teams are ready to provide life-saving care to those in need 24 hours a day, seven days a week; and

WHEREAS, access to quality emergency care dramatically improves both the survival and recovery rate of those who experience sudden illness or injury; and

WHEREAS, emergency medical services have grown to fill a gap by providing important, out-of-hospital care, including preventative medicine, follow-up care and access to telemedicine; and

WHEREAS, the emergency medical services system consists of first responders, emergency medical technicians, paramedics, firefighters, police officers, dispatchers, educators, administrators, pre-hospital nurses, emergency nurses, emergency physicians, trained members of the public and other out-of-hospital medical care providers; and

WHEREAS, the members of emergency medical services teams, whether career or volunteer, engage in thousands of hours of specialized training and continuing education to enhance their life-saving skills; and

WHEREAS, it is appropriate to recognize the value and accomplishments of emergency medical services providers by designating National EMS Week, which was first authorized in 1984 by President Gerald Ford.

NOW, THEREFORE, the Mayor of the City of Arkansas City, Kansas, does hereby proclaim the week of **May 15-21, 2022**, as

NATIONAL EMS WEEK

in Arkansas City, with the theme, “**EMS: Rising to the Challenge,**” and encourage the community to observe this week with appropriate recognition programs, ceremonies and activities.

In witness thereof I have hereunto set my hand and caused this seal to be affixed:

Name/Title: Kanyon Gingher, Mayor
Date: May 3, 2022

Office of the Mayor
Arkansas City, Kansas

Proclamation

WHEREAS, music plays an increasingly important role in our world today; and

WHEREAS, music is one of the most sublime of human pursuits, and is subscribed to by all races and creeds; and

WHEREAS, music is the language of all peoples, and is one of the greatest forces in creating peace and harmony; and

WHEREAS, the National Federation of Music Clubs — dedicated to encouraging young musicians, increasing musical knowledge and advancing American music — and its cooperating organizations join forces annually in **May** to direct attention to the dynamic influence of music in everyday living.

NOW, THEREFORE, the Mayor of the City of Arkansas City, Kansas, does hereby proclaim **May 1-8, 2022**, as

NATIONAL MUSIC WEEK

in Arkansas City, and ask that all citizens of this community observe and take part in activities recognizing the importance of music, musicians, and musical organizations to the cultural life of our city, state, nation and world, and recognizing this year’s theme: “Music... Is Inspiration.”

In witness whereof I have hereunto set my hand and caused this seal to be affixed.

Name/Title: Kanyon Gingher, Mayor
Date: May 3, 2022

Office of the Mayor

Arkansas City, Kansas
Proclamation

WHEREAS, in 1993, the American Nurses Association declared **May 6-12** as the national week to celebrate and elevate the nursing profession, and each year, the celebration ends on **May 12**, which was Florence Nightingale’s birthday; and

WHEREAS, National Nurses Week is a time for everyone — individuals, employers, other health care professionals, community leaders and nurses — to recognize the vast contributions and positive impact of America’s 4 million registered nurses, especially during this challenging past year of pandemic; and

WHEREAS, National Hospital Week is **May 8-14, 2022**, and the official theme is “We Are Health Care”; and

WHEREAS, National Hospital Week celebrates the hospitals, health systems, and men and women who support the health and well-being of communities through dedication and care from the heart; and

WHEREAS, celebrating National Hospital Week provides an opportunity to thank all of the dedicated individuals — physicians, nurses, therapists, engineers, food service workers, volunteers, administrators and more — for their contributions, especially during this trying time of the coronavirus pandemic; and

WHEREAS, the hard-working people who staff our nation’s hospitals, including the registered nurses and other personnel at SCK Health, deserve universal regard and appreciation for keeping our community healthy and safer from COVID-19.

NOW, THEREFORE, the Mayor of the City of Arkansas City, Kansas, does hereby proclaim **May 6-12, 2022**, as

NATIONAL NURSES WEEK

and **May 8-14, 2022**, as

NATIONAL HOSPITAL WEEK

in Arkansas City, and urge residents to express their appreciation for the people, facilities and technologies that make trustworthy, reliable health care possible in our community.

In witness thereof I have hereunto set my hand and caused this seal to be affixed:

Name/Title: Kanyon Gingher, Mayor
Date: May 3, 2022

Office of the Mayor
Arkansas City, Kansas
Proclamation

WHEREAS, Congress and the President of the United States of America have designated **May 15** as Peace Officers Memorial Day and the week in which **May 15** falls as National Police Week; and

WHEREAS, members of the Arkansas City Police Department play an essential role in safeguarding the rights and freedoms of the citizens of our City, especially during this ongoing coronavirus pandemic; and

WHEREAS, it is important that all citizens know and understand the problems, duties, and responsibilities of their police department, and that members of our police department recognize their duty to serve the people by safeguarding life and property, protecting citizens against violence or disorder, and protecting the innocent against deception and the weak against oppression or intimidation; and

WHEREAS, the Arkansas City Police Department has grown to be a modern, scientific and community-focused law enforcement agency that continually provides an essential and vital public service.

NOW, THEREFORE, the Mayor of the City of Arkansas City, Kansas, calls upon all citizens of Arkansas City to observe the week of **May 15-21, 2022**, as

NATIONAL POLICE WEEK

in Arkansas City, with appropriate ceremonies in which all of our people may join in commemorating police officers, past and present, who by their faithful and loyal devotion to their responsibilities have rendered a dedicated service to their communities and, in doing so, have established for themselves an enduring reputation for preserving the rights and security of all citizens.

I FURTHER call upon all citizens of Arkansas City to observe **Sunday, May 15, 2022**, as

PEACE OFFICERS MEMORIAL DAY

in honor of those law enforcement officers who, through their courageous deeds, have lost their lives or become disabled in the performance of duty.

In witness thereof I have hereunto set my hand and caused this seal to be affixed:

Name/Title: *Kanyon Gingher, Mayor*
Date: *May 3, 2022*

Office of the Mayor
Arkansas City, Kansas

Proclamation

WHEREAS, Americans are served every single day by public servants at the federal, state, county and city levels, and these essential workers and unsung heroes keep our nation functioning; and

WHEREAS, public employees take not only jobs, but oaths; and

WHEREAS, many public servants — including military personnel, police officers, firefighters, Border Patrol officers, embassy employees, health care professionals and others — risk their lives each day in service to the people of the United States and around the world, especially during this ongoing COVID-19 pandemic; and

WHEREAS, these public servants include teachers, doctors, scientists, train conductors, astronauts, nurses, safety inspectors, laborers, computer technicians, social workers and countless other occupations that, day in and day out, provide the diverse services demanded by the American people of their government, with both efficiency and integrity; and

WHEREAS, without these dedicated public servants at every level, continuity would be impossible in a representative democracy that regularly changes its leaders and elected officials.

NOW, THEREFORE, the Mayor of the City of Arkansas City, Kansas, does hereby proclaim the week of **May 1-7, 2022**, as

PUBLIC SERVICE RECOGNITION WEEK

in Arkansas City, Kansas, and encourage all citizens to recognize the accomplishments and contributions of government employees at all levels — federal, state, county and city.

In witness thereof I have hereunto set my hand and caused this seal to be affixed:

Name/Title: Kanyon Gingher, Mayor
Date: May 3, 2022



City Commission Agenda Item

Meeting Date: May 3, 2022
From: Lesley Shook, City Clerk
Item: Approving April 19, 2022 Minutes

Purpose: Consent Agenda Item: Approve the April 19, 2022, regular meeting minutes as written.

Background:

Each meeting, the City Commission reviews and approves the minutes of its prior meeting(s).

Commission Options:

- 1. Approve with consent agenda.
- 2. Remove item from consent agenda for further consideration.

Approved for Agenda by:

A handwritten signature in black ink, appearing to read "Randy Frazer", is written over a horizontal line.

Randy Frazer, City Manager



City of Arkansas City

CITY COMMISSION MEETING MINUTES

Tuesday, April 19, 2022 at 5:30 PM – 118 W Central Ave, Arkansas City, KS

Routine Business

- 1. Roll Call

PRESENT

Commissioner Charles Jennings
Commissioner Scott Rogers
Commissioner Diana Spielman
Commissioner Jay Warren
Mayor Kanyon Gingher

- 2. Opening Prayer was led by Gabe Parker and Pledge of Allegiance was led by Aria Smith.

- 3. Additions or Deletions

- Add to the agenda Ordinance No. 2022-04-3476, authorizing and providing for the issuance of Taxable General Obligation Bonds, Series 2022, of the City of Arkansas City Kansas as item #4, and Resolution No. 2022-04-3476 prescribing the form and details of and authorizing and directing the sale and delivery of table General Obligation Bonds as item #5.

Motion made by Commissioner Rogers, seconded by Commissioner Spielman to approve the additions to the agenda

Voting Yea: Commissioner Jennings, Commissioner Rogers, Commissioner Spielman, Commissioner Warren, Mayor Gingher. Mayor Gingher declared the motion approved.

- 4. Approval of the Agenda

Motion made by Commissioner Jennings, Seconded by Commissioner Warren to approve the agenda as amended.

Voting Yea: Commissioner Jennings, Commissioner Rogers, Commissioner Spielman, Commissioner Warren, Mayor Gingher. Mayor Gingher declared the agenda approved as amended.

Awards and Proclamations

- 1. April 22, 2022 was proclaimed as Earth Day and April 29, 2022, as Arbor Day in Arkansas City as read by Armoni Evans.

Consent Agenda

Note: All matters listed below on the Consent Agenda are considered under one motion and enacted by one motion.

There should be no separate discussion. If such discussion is desired, any item may be removed from the Consent Agenda and then considered separately under Section VII: New Business.

Motion made by Commissioner Rogers, Seconded by Commissioner Warren to approve the consent agenda as presented.

- 1. Approve the April 5, 2022, regular meeting minutes as written.
- ~~2. Consider a Resolution approving a recommendation of the Arkansas City Beautification and Tree Advisory Board to initiate an adoption contract for one year with the Friends of Wilson Park for the old fountain in the Docking Memorial Garden at Wilson Park, located at 701 N. Summit St. in Arkansas City.~~

Following discussion, it was the consensus of the commission to omit “the old fountain in” to read as, a Resolution approving a recommendation of the Arkansas City Beautification and Tree Advisory Board to initiate an adoption contract for one year, with the Friends of Wilson Park for the Docking Memorial Garden in Wilson Park, located at 701 N. Summit St. in Arkansas City from item #2 under the Agenda, and relocate to Old Business, item #1.

Motion made by Commissioner Rogers, Seconded by Commissioner Warren to approve the consent agenda as amended.

Voting Yea: Commissioner Jennings, Commissioner Rogers, Commissioner Spielman, Commissioner Warren, Mayor Gingher. Mayor Gingher declared the agenda approved as amended.

Old Business

- 1. Deputy City Clerk Parsons presented for discussion a Resolution approving a recommendation of the Arkansas City Beautification and Tree Advisory Board to initiate an adoption contract for one year, with the Friends of Wilson Park, for the Docking Memorial Garden in Wilson Park, located at 701 N. Summit St. in Arkansas City.

Motion made by Mayor Gingher, Seconded by Commissioner Warren to approve the Resolution approving a recommendation of the Arkansas City Beautification and Tree Advisory Board to initiate an adoption contract for one year, with the Friends of Wilson Park, for the Docking Memorial Garden in Wilson Park, located at 701 N. Summit St. in Arkansas City.

Voting Yea: Commissioner Jennings, Commissioner Rogers, Commissioner Spielman, Commissioner Warren, Mayor Gingher. Mayor Gingher declared the motion approved and given **Resolution No. 2022-04-3477.**

New Business

Resolutions & Ordinances for Consideration

- 1. Deputy City Clerk Parsons presented for discussion a Resolution authorizing the City of Arkansas City to accept a bid submitted by Melton Industries, of Wichita,KS for the company can apply urethane coating to the entire roof at the Fire Department, for an amount not to exceed \$49,975.00. Public Services Superintendent Tapia noted to the commission that the urethane coating was to be applied to the two lower levels of the Fire Department. Public Services Superintendent Tapia mentioned the bid was within budget and reserves a 12-year warranty.

Motion made by Commissioner Warren, seconded by Commissioner Spielman to approve the bid submitted by Melton Industries, of Wichita, KS for the company can apply urethane coating to the two lower levels of the Fire Department, for amount not to exceed \$49,975.00.

Voting Yea: Commissioner Jennings, Commissioner Rogers, Commissioner Spielman, Commissioner Warren, Mayor Gingher. Mayor Gingher declared the motion approved and given **Resolution No. 2022-04-3478.**

2. Deputy City Clerk Parsons presented for discussion a Resolution authorizing the City of Arkansas City to accept a bid, submitted by Truck Center Companies of Wichita, KS, to purchase a 2022 FTR Isuzu Two and Half Ton Truck for the Sanitation Department, for an amount not to exceed \$98,953.00.

Public Services Superintendent Tapia explained to the Commission that this new two and half ton truck is larger and better able to be used for hauling trees and does not require a Commercial Driver's License to operate the truck. The new truck would replace the existing truck, which would be utilized with the Street/Sanitation Department.

Motion made by Commissioner Spielman, seconded by Commissioner Jennings to accept the bid, submitted by Truck Center Companies of Wichita, KS, to purchase a 2022 FTR Isuzu Two and Half Ton Truck for the Sanitation Department, for an amount not to exceed \$98,953.00.

Voting Yea: Commissioner Jennings, Commissioner Rogers, Commissioner Spielman, Commissioner Warren, Mayor Gingher. Mayor Gingher declared the motion approved and given **Resolution No. 2022-04-3479.**

3. Deputy City Clerk Parsons presented for discussion a Resolution authorizing the City of Arkansas City to accept a bid submitted by Clark Equipment Company, of West Fargo, ND, to purchase a 2022 T66 T4 Bobcat Track Loader to replace the current #3014 Skid Steer at the Parks Department, for an amount not to exceed \$60,200.91.

Public Services Superintendent Tapia addressed that this unit would replace a 2001 unit that was a hammy down from the street department that is limited in the ability to get into certain terrain and currently leaks.

Motion made by Commissioner Spielman, seconded by Commissioner Warren to accept the bid, submitted by Clark Equipment Company, of West Fargo, ND, to purchase a 2022 T66 T4 Bobcat Track Loader to replace the current #3014 Skid Steer at the Parks Department, for an amount not to exceed \$60,200.91.

Voting Yea: Commissioner Jennings, Commissioner Rogers, Commissioner Spielman, Commissioner Warren, Mayor Gingher. Mayor Gingher declared the motion approved and given **Resolution No. 2022-04-3480.**

- 4&5. Deputy City Clerk Parsons presented for discussion an ordinance authorizing and providing for the issuance of taxable general obligation bonds, series 2022 of the City of Arkansas City Kansas; Providing for the levy and collection of an annual tax for the purpose of paying the principal of and interest on said bonds as they become due; authorizing certain other documents and actions in connection therewith; and making certain covenants with respect thereto and a Resolution prescribing the form and details of and authorizing and directing the sale and delivery of table general obligation bonds, service 2022 of the City of Arkansas City, Kansas, previously authorized by Ordinance No. 2022 04-4553 of the issuer; making certain covenants and agreement to provide for the payment and security thereof; and authorizing certain other documents and auction connected therewith.

Larry Kleeman with Ranson Financial Group, LLC discussed the bids concerning the issuance of taxable general obligation bonds.

Motion made by Commissioner Warren, seconded by Commissioner Rogers, to accept Ordinance No. 2022-04-4553 and Resolution No. 2022-04-3476 subject to the City's receipt of the good faith deposit.

Voting Yea: Commissioner Jennings, Commissioner Rogers, Commissioner Spielman, Commissioner Warren, Mayor Gingher. Mayor Gingher declared the motion approve and given **Ordinance No. 2022-04-4553** and **Resolution No. 2022-04-3476**.

Staff Report Presentations

- 1. March 2022 Financial Summary
- 2. City Manager Frazer provided the commissioners with the following reminders and updates:
 - Commissioners were able to review the March 2022 Financial Summary available in the packet.
 - On May 4th, a dinner was held for South Central Kansas Businesses where KanPak won regional award from the Department of Commerce, as an Industrial Business, and will represent one of the fourth recognized across the state on May 11th.
 - Friday, May 6th will be the first Budget Retreat from noon-3 pm at the Water Treatment Plan meeting room.

Adjournment

Motion made by Commissioner Warren, Seconded by Commission Spielman seconded to adjourn the meeting.

Voting Yea: Commissioner Jennings, Commissioner Rogers, Commissioner Spielman, Commissioner Warren, Mayor Gingher. Mayor Gingher declared the meeting adjourned.

**THE CITY OF ARKANSAS CITY
BOARD OF CITY COMMISSIONERS**

Kanyon Gingher, Mayor

ATTEST:

Tiffany Parsons, Deputy City Clerk

Prepared by:

Tiffany Parsons, Deputy City Clerk



City Commission Agenda Item

Meeting Date: May 3, 2022
From: Tiffany Parsons, Deputy City Clerk
Item: Board Appointment

Purpose: Consent Agenda Item: Ratify Mayor Canyon Gingher’s appointment of Katie Boyle to the Arkansas City Public Library Board of Trustees.

Background:

Katie Boyle, had expressed an interest in joining this committee. Kaite has a extensive background in both community and professional involvement in both education and library settings, including serving as treasurer for the Southeast Kansas Library System Executive Board of Directors. She is currently employed by StackMap as a Customer Experience Lead/Librarian.

Staff and Mayor Gingher recommend that Ms. Boyle be appointed to the Arkansas City Public Library Board of Trustees.

Commission Options:

- 1. Approve with consent agenda.
- 2. Remove from consent agenda for further consideration.

Attachments:

- 1. Katie Boyle’s Application Form

Approved for Agenda by:

A handwritten signature in black ink, appearing to read "Randy Frazer", written over a horizontal line.

Randy Frazer, City Manager

City Volunteer Form for Boards, Commissions and Committees

Name: Katie Boyle
Phone: (316) 323-3432
Alternate Phone: _____
Email: kboyle1028@gmail.com

Home Address: 129 Highland Dr.
Employment: StackMap
Job Title: Customer Experience Lead/Librarian
Years Lived in Arkansas City: 6

Community and Professional Activities/Associations/Honors/Organizations:
Jefferson Elementary PTO Treasurer, Five-Year Strategic Planning Committee USD 470, Kansas Library Association Conference Committee, Emporia State University Student Chapter American Library Association Representative, Big Brothers Big Sisters Board Member, and Meals on Wheels Board Member.

Previous Civic Experience (please list any appointed or elected positions you have held in the past):
Southeast Kansas Library System Executive Board of Directors - Treasurer

Appointment(s) you are applying for [please indicate all of your choice(s) – when a vacancy occurs, you will be contacted; also, please note you may serve on only two (2) of these boards at one time]:

- | | | | |
|-------------------------------------|---|--------------------------|---------------------------------------|
| <input checked="" type="checkbox"/> | ACPL (Public Library) Board of Trustees | <input type="checkbox"/> | Northwest Community Center Board |
| <input type="checkbox"/> | Beautification and Tree Advisory Board | <input type="checkbox"/> | Outstanding Student Award Committee |
| <input type="checkbox"/> | Building Trades Board* | <input type="checkbox"/> | Planning Commission / Board of Zoning |
| <input type="checkbox"/> | Capital Improvement Planning Committee | <input type="checkbox"/> | Public Building Commission |
| <input type="checkbox"/> | City Commission <i>(only if vacancy occurs)</i> | <input type="checkbox"/> | Recreation Commission |
| <input type="checkbox"/> | Community Spirit Award Committee | <input type="checkbox"/> | SCKMC (Hospital) Board of Trustees |
| <input type="checkbox"/> | Equal Opportunity & Accessibility Board | <input type="checkbox"/> | Traffic Safety Committee |
| <input type="checkbox"/> | Historic Preservation Board | <input type="checkbox"/> | Visit Ark City Board of Trustees |

**Professional certifications required – call (620) 441-4415 or (620) 441-4420 for more information!*

Please indicate why you are interested in serving and what skills you might contribute: _____
I want to serve on the ACPL Board because I have a passion for libraries. I have worked in libraries for over twelve years, including at ACPL, and I hold a Master of Library Science. Libraries are essential to communities and their patrons, and I want to be a part of the library's future and its role in serving our community

Signature: _____ Date: 4/7/22

~~~Applicants must be appointed by the Mayor with the consent of the City Commission~~~

Mail or Deliver to:  
Lesley Shook, City Clerk OR Andrew Lawson, Public Information Officer  
City of Arkansas City  
118 W. Central Ave.  
Arkansas City, KS 67005

Or you can email this form to: [lshook@arkansascityks.gov](mailto:lshook@arkansascityks.gov) or [alawson@arkansascityks.gov](mailto:alawson@arkansascityks.gov)



# City Commission Agenda Item

**Meeting Date:** May 3, 2022  
**From:** Randy Frazer, City Manager  
**Item:** 2022-2023 Insurance Renewal

**Purpose:**

Consider approval of City insurance coverage for property, liability, vehicles and equipment. (Voice Vote)

**Background:**

The City received a quote for comprehensive insurance coverage — excluding workers compensation insurance, which is provided by Kansas Municipal Insurance Trust — for the period April 1, 2022 thru March 31, 2023.

The following is a four-year prior comparison of the City’s current providers, Wichita-based EMC Insurance Companies and United Agency, Inc., with quotes for the upcoming year in the right column:

| <i>April 1 — March 31</i>  | Prior Insurance Levels |                  |                  | Current Insurance | EMC Proposal     |
|----------------------------|------------------------|------------------|------------------|-------------------|------------------|
|                            | 2018-2019              | 2019-2020        | 2020-2021        | 2021-2022         | 2022-2023        |
| <b>Commercial Property</b> | \$102,557              | \$133,204        | \$124,067        | \$131,052         | \$145,862        |
| <b>Inland Marine</b>       | 11,200                 | 11,200           | 11,432           | 14,208            | 11,094           |
| <b>Crime/Fidelity</b>      | 569                    | 455              | 566              | 540               | 540              |
| <b>Business Auto</b>       | 68,096                 | 76,419           | 66,818           | 68,896            | 72,246           |
| <b>General Liability</b>   | 29,245                 | 32,468           | 38,958           | 43,035            | 46,744           |
| <b>Law Enforcement</b>     | 9,225                  | 9,225            | 7,539            | 8,293             | 9,955            |
| <b>Linebacker</b>          | 10,976                 | 12,113           | 12,786           | 19,854            | 19,248           |
| <b>Cyber Liability</b>     | 660                    | 660              | 2,509            | 2,509             | 2,509            |
| <b>TOTAL PREMIUM</b>       | <b>\$232,528</b>       | <b>\$275,744</b> | <b>\$264,675</b> | <b>\$288,387</b>  | <b>\$308,198</b> |

**Commission Options:**

1. Approve insurance renewal for 2022-2023.
2. Disapprove insurance renewal for 2022-2023.
3. Table this item for further discussion.

**Fiscal Impact:**

Amount: \$308,198

Fund: General, Water, Sewer & Sanitation Department: Various Expense Code: 6215 (Insurance)

Included in budget  Grant  Bonds

Other (explain) Costs are allocated depending upon item value/department.

**Approved for Agenda by:**



---

Randy Frazer, City Manager





BUSINESS PROTECTION POLICY  
COMMON DECLARATIONS

POLICY PERIOD

FROM: SEE SECTION DECLARATIONS TO: 04/01/23  
12:01 A.M. STANDARD TIME

AT YOUR MAILING ADDRESS SHOWN BELOW  
(UNLESS CHANGED ON THE SECTION DECLARATIONS)

\*-----\*  
\* ACCOUNT NUMBER \*  
\* 8X97914---23 \*  
\*-----\*

NAMED INSURED :

PRODUCER :

CITY OF ARKANSAS CITY  
PO BOX 778  
ARKANSAS CITY KS 67005-0778

UNITED AGENCY INC  
726 N SUMMIT ST  
PO BOX 817  
ARKANSAS CITY KS 67005-0817

AGENT: L 7433  
AGENT PHONE: (620)442-0400  
CLAIM REPORTING: (888)362-2255

-----  
INSURED IS: GOV'T SUBDIV BUSINESS DESC: MUNICIPALITY  
-----

IN RETURN FOR THE PAYMENT OF THE PREMIUM, AND SUBJECT TO ALL THE TERMS OF THIS POLICY, WE AGREE WITH YOU TO PROVIDE THE INSURANCE AS STATED IN THIS POLICY. THIS POLICY CONSISTS OF THE FOLLOWING COVERAGE PARTS FOR WHICH A PREMIUM IS INDICATED. THIS PREMIUM MAY BE SUBJECT TO ADJUSTMENT. THE COMPANY AFFORDING COVERAGE IS DESIGNATED BY THE NAME IN THE DECLARATIONS OR INFORMATION PAGE FOR EACH SECTION OF THE POLICY.

| SECTION | COVERAGE              | PREMIUM       |
|---------|-----------------------|---------------|
| 1       | PROPERTY              | \$ 145,862.00 |
| 2       | LIABILITY             | 46,744.00     |
| 3       | CRIME                 | 540.00        |
| 4       | INLAND MARINE         | 11,094.00     |
| 5       | AUTOMOBILE            | 72,246.00     |
| 6       | WORKERS' COMPENSATION | NO COVERAGE   |
| 7       | UMBRELLA              | NO COVERAGE   |
| 8       | OTHER - LINEBACKER    | 19,248.00     |
|         | LAW ENFORCEMENT       | 9,955.00      |
|         | CYBERSOLUTIONS        | 2,509.00      |

-----  
ESTIMATED TOTAL POLICY PREMIUM \$ 308,198.00  
-----

FORMS APPLICABLE TO ALL SECTIONS EXCEPT:  
1. WORKERS' COMPENSATION

THE ADDRESS AND TELEPHONE NUMBER OF THE SERVICING COMPANY IS:  
EMC INSURANCE COMPANIES PHONE: (316) 352-5700  
245 N WACO ST STE 330  
WICHITA, KS. 67202-1116

PLACE OF ISSUE: WICHITA, KS  
DATE OF ISSUE: 04/05/22 COUNTERSIGNED BY:

FORM: IL7000A (ED. 09-02) 04/05/22 KB 8X97914 23



# City Commission Agenda Item

**Meeting Date:** May 3, 2022  
**From:** Tony Tapia, Public Services Superintendent  
**Item:** Purchase 6” Super Vac Assist Diesel Pump

**Purpose:** Consider a Resolution authorizing the City of Arkansas City to accept a bid submitted by United Rentals, of Park City, KS, to purchase a 6” Super Vac Assist Diesel Pump for the Street/Stormwater Department, for an amount not to exceed \$39,900.00. **(Voice Vote)**

**Background:**

Bids were sent out for the purchase of a 6” pump, however due to a pump shortage and companies not wanting to sell used pumps, only two bids were received.

Staff recommends purchasing the 6” Super Vac Assist Diesel Pump for the Street/Stormwater Department, for an amount not to exceed \$39,900.00. The pump is used but in great condition for a used pump, and is available immediately.

**Commission Options:**

1. Approve the Resolution.
2. Disapprove the Resolution.
3. Table the Resolution for further discussion.

**Fiscal Impact:**

Amount: \$39,900.00

Fund: **015-Stormwater** Department: **544-Stormwater** Expense Code: **7405-Machinery/Equipment**

Included in budget       Grant       Bonds       Other Not Budgeted

**Attachments:** Bid Sheet and Quotes.

**Approved for Agenda by:**

Randy Frazer, City Manager

RESOLUTION NO. 2022-04-\_\_\_\_\_

**A RESOLUTION AUTHORIZING THE CITY OF ARKANSAS CITY TO ACCEPT A BID SUBMITTED BY UNITED RENTALS, OF PARK CITY, KS, TO PURCHASE A 6” SUPER VAC ASSIST DIESEL PUMP FOR THE STREET/STORMWATER DEPARTMENT, FOR AN AMOUNT NOT TO EXCEED \$39,900.00.**

**BE IT RESOLVED BY THE GOVERNING BODY OF THE CITY OF ARKANSAS CITY, KANSAS:**

**SECTION ONE:** The Governing Body of the City of Arkansas City, Kansas, hereby authorizes the City of Arkansas City, Kansas, to accept a bid submitted by United Rentals, of Park City, KS, to purchase a 6” Super Vac Assist Diesel Pump for the Street/Stormwater Department, for an amount not to exceed \$39,900.00.

**SECTION TWO:** The Governing Body of the City of Arkansas City, Kansas, hereby authorizes the Mayor and/or City staff of the City of Arkansas City, Kansas, to take such further and other necessary actions that are required to effectuate the intent and purposes of this Legislative Enactment.

**SECTION THREE:** This Resolution shall be in full force and effect from its date of passage by the Governing Body of the City of Arkansas City, Kansas.

**PASSED AND RESOLVED** by the Governing Body of the City of Arkansas City, Kansas, on this 3<sup>rd</sup> day of May, 2022.

(Seal)

\_\_\_\_\_

Kanyon Gingher, Mayor

ATTEST:

\_\_\_\_\_

Lesley Shook, City Clerk

APPROVED AS TO FORM:

\_\_\_\_\_

Larry R. Schwartz, City Attorney

**CERTIFICATE**

I hereby certify that the above and foregoing is a true and correct copy of the Resolution No. 2022-04-\_\_\_\_\_ of the City of Arkansas City, Kansas, adopted by the Governing Body thereof on May 3, 2022, as the same appears of record in my office.

DATED: \_\_\_\_\_.

\_\_\_\_\_

Lesley Shook, City Clerk

**6" Diesel Pump**

| COMPANY       | United Rentals                         | MWI Pumps                                              |
|---------------|----------------------------------------|--------------------------------------------------------|
| PUMP MODEL    | 6" Super Vac Assist Diesel Pump (Used) | 6" Diesel Driven MWI Prime Rite Centrifugal Pump (New) |
| TOTAL COST    | \$ 39,900.00                           | \$ 42,093.00                                           |
| DELIVERY TIME | Wichita,KS location ready for pickup   | 8-10 Week lead time once purchase is made              |
| MEET SPECS    | Yes-6" Suction/Discharge size          | Yes-6" Suction/Delivery connection                     |
| MEET SPECS    | Yes-Diesel Engine                      | Yes-Diesel Engine                                      |
| WARRENTY      | N/A                                    | 1-Year manufacturer's Warrenty                         |

Budgeted amount for this is \$39,000

Recommendation would be the 6" Super Vac Assist Diesel Pump (Used) due to meeting budget.



EQUIPMENT SALE  
QUOTE

Section , Item 1.

FLUID SOLUTIONS  
BRANCH 28R  
8325 NORTH HYDRAULIC STREET  
PARK CITY KS 67147  
316-776-4405  
805-655-7605 FAX

# 204494852

Job site

CITY OF ARK CITY  
815 W MADISON AVE  
ARKANSAS CITY KS 67005-3035

Office: 620-441-4426 Cell: 620-446-0359

Customer # : 1406007  
Quote Date : 03/24/22  
  
UR Job Loc : 815 W MADISON AVE, A  
UR Job # : 1  
Customer Job ID:  
P.O. # : TBD  
Ordered By : BRIAN EDWARDS  
Written By : RICHARD LOVELESS  
Salesperson : RONNIE KILGORE

CITY OF ARKANSAS CITY  
PO BOX 778  
ARKANSAS CITY KS 67005-0778

**This is not an invoice  
Please do not pay from this document**

| Qty                                           | Equipment #                                                                                                                                                                   | Price    | Amount   |
|-----------------------------------------------|-------------------------------------------------------------------------------------------------------------------------------------------------------------------------------|----------|----------|
| 1                                             | NP2D663017 CC: 520-2008<br>PUMP 6" SUPER VAC ASSIST - DIESEL<br>Make: PIONEER Model: PP66S14L71D914 Serial #: PP22641<br>Model Year: 13 Lic: M015934<br>HR OUT: 8298.700<br>N | 39900.00 | 39900.00 |
| Sub-total:                                    |                                                                                                                                                                               |          | 39900.00 |
| Total:                                        |                                                                                                                                                                               |          | 39900.00 |
| CONTACT: BRIAN EDWARDS<br>CELL#: 620-446-0359 |                                                                                                                                                                               |          |          |

Note: This proposal may be withdrawn if not accepted within 30 days.

THIS IS NOT AN EQUIPMENT SALE AGREEMENT/INVOICE. THE SALE OF EQUIPMENT AND ANY OTHER ITEMS LISTED ABOVE IS SUBJECT TO AVAILABILITY AND ACCEPTANCE OF THE TERMS AND CONDITIONS OF UNITED'S EQUIPMENT SALE AGREEMENT/INVOICE, WHICH MUST BE SIGNED PRIOR TO OR UPON DELIVERY OF THE EQUIPMENT AND OTHER ITEMS.



PP66S14 - Data Sheet

# 6" Diesel Pump

## Vacuum Assisted

### Product Description

Diesel engine driven centrifugal pump equipped with vacuum-assisted priming system. Trailer mounted for easy transportation having the following additional features: Run dry mechanical seal, Auto-start control, monitoring of fuel level, engine load, run time, oil and coolant temperature, and telemetry system.

### Technical Data

#### Operating Parameters

|                          |                                  |
|--------------------------|----------------------------------|
| Min. / Max. Flow         | 377 gpm / 3250 gpm               |
| Min. / Max. Shutoff Head | 101 ft (44psi) / 267 ft (116psi) |
| Maximum Casing Pressure  | 260 psi                          |
| Maximum Temperature      | 200°F                            |
| Maximum Solid Size       | 3 inch                           |
| Min. / Max. Pump Speed   | 1200 rpm / 1950 rpm              |

#### Pump & Accessory Specifications

|                                 |                    |
|---------------------------------|--------------------|
| Suction / Discharge Size        | 6 inch / 6 inch    |
| Impeller Diameter               | 14 inch            |
| Vacuum System - Type / Capacity | Diaphragm / 50 CFM |

|                             |                                                                |
|-----------------------------|----------------------------------------------------------------|
| Casing                      | Ductile Iron ASTM A536 65-45-12                                |
| Impeller                    | CA6NM Stainless Steel                                          |
| Wear Ring                   | ASTM A48 Class 40 Gray Iron                                    |
| Shaft                       | 17-4PH Stainless Steel                                         |
| Mechanical Seal Faces       | Tungsten-Carbide vs Silicon-Carbide                            |
| Mechanical Seal Lubrication | ISO Viscosity Grade 32 or Lower <i>(synthetic recommended)</i> |
| O-rings & Gaskets           | Buna-N & Viton                                                 |
| Check Valve Body            | Ductile Iron                                                   |
| Check Valve Flapper         | Buna-N                                                         |
| Check Valve Type            | Swing type                                                     |

#### Driver Properties

|                        |                                          |
|------------------------|------------------------------------------|
| Driver Type            | Diesel Engine                            |
| Driver Make            | Duetz                                    |
| Model                  | TCD914L6                                 |
| Max. Continuous Rating | 174 hp                                   |
| Total Displacement     | 6.5 liters                               |
| Aspiration             | Turbocharged Charge-Air Cooled           |
| Number of Cylinders    | 6                                        |
| Safety Shutdowns       | Low Oil Pressure ,<br>V Belt , High Temp |
| Fuel Consumption       | 6.9 gal/hr @ 1800 rpm                    |
| Run Time               | 19.5 hours @ 1800 rpm                    |
| Fuel Type              | No. 2 Diesel: <b>NO BIODIESEL</b>        |
| Fuel Capacity          | 135 U.S. gallons                         |

#### Type A

### Notes

- Performance data based on water at 60°F
- Run time indicated is for reference and could vary based on speed and engine loads
- Maximum temperature is the equipment material limitation. Based on the application, process, product and NPSH requirements, the maximum allowable temperature could be lower
- This pump is also available with a 20 CFM venturi-compressor priming system

#### Type B

|                        |                                        |
|------------------------|----------------------------------------|
| Driver Type            | Diesel Engine                          |
| Driver Make            | John Deere                             |
| Model                  | 6068HF285                              |
| Max. Continuous Rating | 173 hp                                 |
| Total Displacement     | 6.8 liters                             |
| Aspiration             | Turbocharged and air-to-airaftercooled |
| Number of Cylinders    | 6                                      |
| Safety Shutdowns       | Low Oil Pressure,<br>High Temp.        |
| Fuel Consumption       | 6.8 gal/hr @ 1800 rpm                  |
| Run Time               | 19.7 hours @ 1800 rpm                  |
| Fuel Type              | No. 2 Diesel: <b>NO BIODIESEL</b>      |
| Fuel Capacity          | 135 U.S. gallons                       |



PP66S14 - Data Sheet

# 6" Diesel Pump

## Vacuum Assisted

### Dimensional Drawing

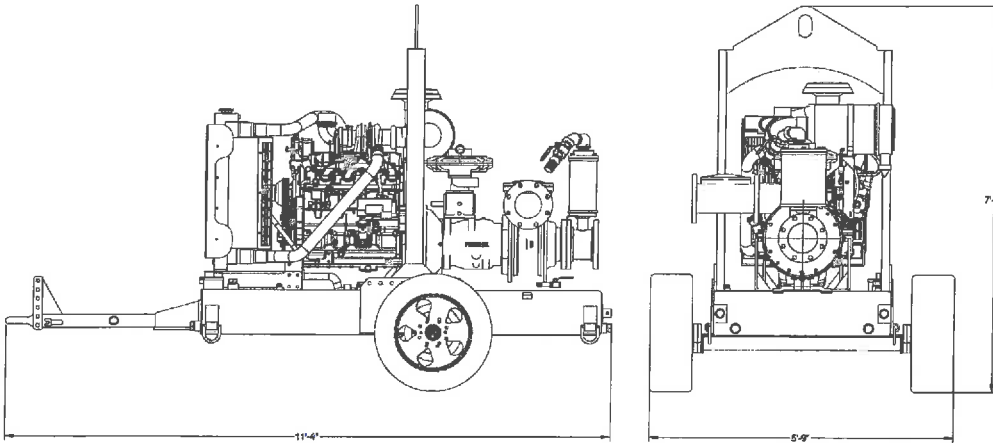

### Dimensional Details

| Type A               |          |
|----------------------|----------|
| Total Weight wo/Fuel | 3600 lbs |
| Total Weight w/Fuel  | 4560 lbs |
| Overall Height       | 78 inch  |
| Overall Width        | 67 inch  |
| Overall Length       | 145 inch |
| Type B               |          |
| Total Weight wo/Fuel | 3720 lbs |
| Total Weight w/Fuel  | 4680 lbs |
| Overall Height       | 87 inch  |
| Overall Width        | 69 inch  |
| Overall Length       | 136 inch |

### Performance Curve

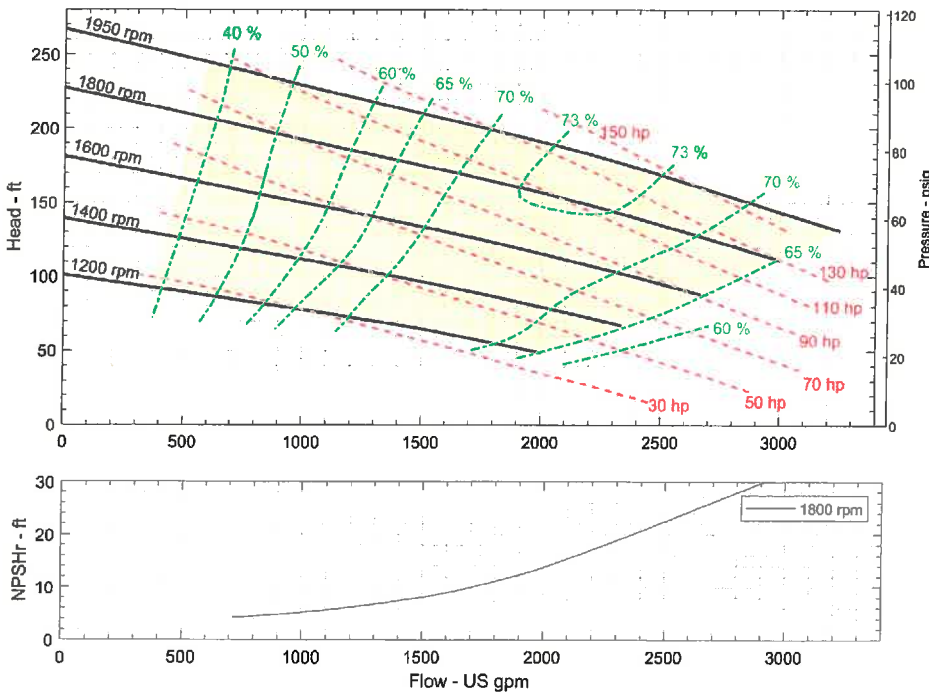

|                       |               |
|-----------------------|---------------|
| Pump Make             | Pioneer Pump  |
| Pump Model            | PP66S14       |
| Operating Speed       | Variable      |
| Min. Speed            | 1200 rpm      |
| Max. Speed            | 1950 rpm      |
| Impeller Rated Dia.   | 14 inch       |
| Impeller Type         | Enclosed      |
| No. of Impeller Vanes | 2             |
| Solid Dia.            | 3 inch        |
| Specific Speed        | 1832 US Units |
| Suction Size          | 6 inch        |
| Discharge Size        | 6 inch        |



100 First Stamford Place, Ste 700  
Stamford, Ct 06902 | USA

UnitedRentals.com | 800.UR.RENTS

© 2018 United Rentals, Inc.



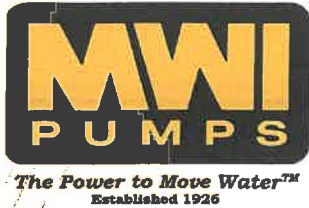

OE Manufacturers, Rental and Repair

Moving Water Worldwide - Reliably and Efficiently

New

Section , Item 1.

Date: 4/21/2022

**Equipment Sale Quote**

**MWI Pump Rentals**  
 7555 Wilson Blvd.  
 Jacksonville, FL 32210  
 Office: (904) 425-6741  
 Fax: (407) 854-3376  
 Cell: (904) 333-2088  
 Sales Rep: Eric Gregory  
[Ericg@mwipumps.com](mailto:Ericg@mwipumps.com)  
<https://MwiPumps.com/>

**Customer Information**

Name: Arkansas City Kansas  
 Contact: Brian Edwards  
 Address:  
 City, State: Arkansas City Kansas  
 Zip:  
 Phone: (620) 441-4460  
 Fax:  
 Cell: (620) 446-0359  
 Email: [bedwards@arkansascityks.gov](mailto:bedwards@arkansascityks.gov)

**Job Site Information**

Name: Arkansas City Kansas  
 Contact: Brian Edwards  
 Address: 0  
 City, State: Arkansas City Kansas  
 Zip: 0  
 Phone: (620) 441-4460  
 Fax: -  
 Cell: (620) 446-0359  
 Email: [bedwards@arkansascityks.gov](mailto:bedwards@arkansascityks.gov)

Signature: \_\_\_\_\_

PO #: \_\_\_\_\_

| Qty | Description                                                | Part Number | Unit Price   | Extended Price |
|-----|------------------------------------------------------------|-------------|--------------|----------------|
| 1   | CT006D - 6" Diesel Driven MWI Prime Rite Centrifugal Pump. | ct006       | \$ 42,093.00 | \$ 42,093.00   |

Equipment Sales Quote is valid through: 5/21/2022

|                            |                     |
|----------------------------|---------------------|
| Subtotal                   | \$ 42,093.00        |
| Transportation Charges     | TBD                 |
| Loss Damage Waiver         | \$                  |
| Environmental Recovery Fee | \$                  |
| Estimated Taxes            | TBD                 |
| <b>Estimated Total</b>     | <b>\$ 42,093.00</b> |

Comments:

\*1 Year Manufacturer's - Warranty Information Attached  
 \*8-10 Week Lead Time Upon Receipt of Signed Quote & Purchase Orders  
<https://mwipumps.com/product/>

**MWI Pump Rental Jacksonville**

7555 Wilson Blvd., Jacksonville, FL 32210 | Phone: (904) 425-6741 | Fax: (407) 854-3376 | [www.mwipumps.com](http://www.mwipumps.com)



*The Power to Move Water™*  
Established 1926

*OE Manufacturers, Rental and Repair*

*Moving Water Worldwide - Reliably and Efficiently*

**MWI Pump Rental Jacksonville**

7555 Wilson Blvd., Jacksonville, FL 32210 | Phone: (904) 425-6741 | Fax: (407) 854-3376 | [www.mwipumps.com](http://www.mwipumps.com)

# PRIMERITE™ CT006

## 6" X 6" AUTOMATIC DRY SELF-PRIMING TRASH PUMP



The Power to Move Water®

### APPLICATIONS

Construction  
Dewatering

Sewage Bypass

Flood Drainage

Mining/Quarries

Municipal

General Industrial

The Primerite™ is the perfect pump for contractors, pump rental companies, mining operators and general industrial or municipal use. The pump's oil-filled bearing box and a mechanical seal in an oil bath enable it to run dry all day long for up to 24 hours, making it the right choice for handling inconsistent flows found in sewage bypass pumping and job site dewatering. This pump is completely self contained in either skid or trailer configurations with integral lifting bail, tie downs and fuel tank.

### FEATURES

- Primes and reprimed automatically
- Solids handling up to 3"
- Engine driven compressor
- Vacuum and discharge pressure gauge
- Lockable fuel cap
- Forklift slots (skid models)
- Torsion bar axle
- Integral 78 fuel tank with gauge
- Skid or optional trailer-mounted
- DOT light kit available
- Hydraulic surge brakes standard, electric brakes available
- Front and rear stabilizing jacks
- 3" Lunette ring for pintle hitch – Other options available
- Lifting bail
- Volute drain
- Heavy-duty truck tie downs
- Engines – Caterpillar, Perkins, John Deere and Deutz available
- Flexible flywheel coupling
- 6" ANSI Pattern flanges – Suction and discharge
- Optional float activated, auto start/stop controls
- Manufactured in the USA

### QUICK SPECIFICATIONS

|                           |                                |
|---------------------------|--------------------------------|
| Suction connection        | 6" 150# ANSI B16.5             |
| Delivery connection       | 6" 150# ANSI B16.5             |
| Max capacity              | 2300 USGPM                     |
| Max solids handling       | 3.0"                           |
| Max impeller diameter     | 10.8"                          |
| Max head (TDH)            | 160'                           |
| Max operating speed       | 2000 RPM                       |
| Max suction lift          | 25'                            |
| Dimensions                | 65 x 93 x 132"                 |
| Sound levels w/ enclosure | 67 dBA at 7M / 23'             |
| Max fuel consumption      | At 67 HP; up to 20 hr run time |



## PERFORMANCE CURVE

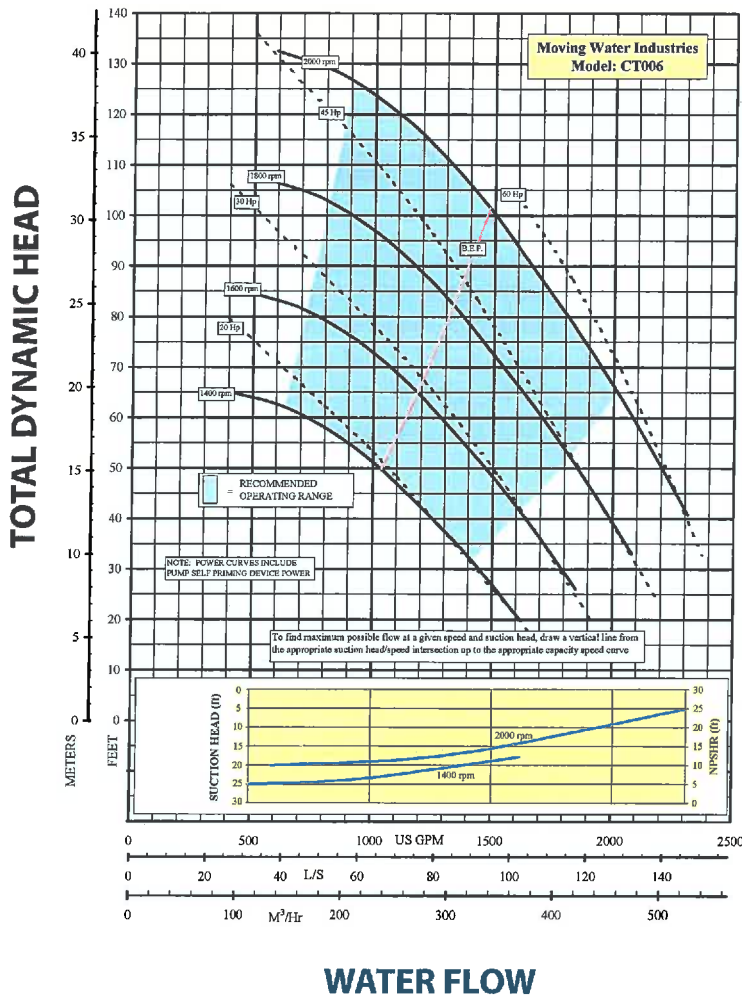

## DIMENSIONS

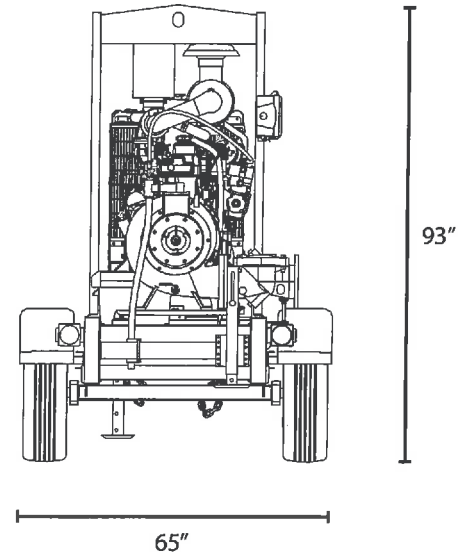
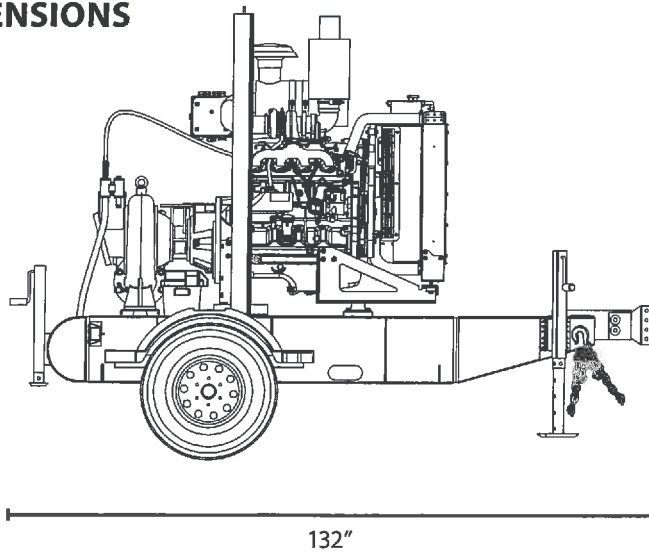

### MWI Pumps Headquarters

33 NW 2nd Street | Deerfield Beach, FL 33441

Copyright © 2020 MWI Pumps | All rights reserved. Subject to change without notice.

Inquiries: 954-426-1500 | Fax: 954-426-8938 | Email: info@mwipumps.com | [mwipumps.com](http://mwipumps.com)

## MATERIALS & SPECIFICATIONS

|                                |                                                                                                                               |
|--------------------------------|-------------------------------------------------------------------------------------------------------------------------------|
| Standard engine                | John Deere 4045TF290                                                                                                          |
| Max HP                         | 74 HP                                                                                                                         |
| Fuel capacity                  | 78 Gal                                                                                                                        |
| Drive type                     | Flywheel direct drive<br>flexible element                                                                                     |
| Impeller                       | CA-40 Corrosion resistant<br>iron/chromium alloy                                                                              |
| Volute                         | Ductile cast iron ASTM A536 grade<br>70-50-05                                                                                 |
| Pump shaft                     | 1045 Steel; Stainless steel option                                                                                            |
| Compressor                     | Engine-driven, oil lubricated and<br>water cooled                                                                             |
| Priming assembly               | 304 Stainless steel venturi                                                                                                   |
| Control panel                  | Tach and hour meter, including<br>shutdowns for low oil pressure, high<br>coolant temperature, Plug-N-Play<br>and float-ready |
| Discharge non-return valve     | Val-matic swing flex check valve<br>ASTM A536 grade 65-45-12                                                                  |
| Mechanical seal                | Stainless steel with silicon carbide<br>faces; Buna elastomers                                                                |
| Weight of trailer mounted unit | 3450 lbs (dry)                                                                                                                |

PRIMERITE™ CT006



# City Commission Agenda Item

**Meeting Date:** May 3, 2022  
**From:** Randy Frazer, City Manager  
**Item:** City Manager Updates

**Purpose:** City Manager's Report on Upcoming Activities

**Background:**

1. The next City Commission study session will be the **Budget Work Session/Commission Retreat at noon on Friday, May 6<sup>th</sup>** in the Water Treatment Facility training room, located at 400 W. Maddison Ave. Auditor, Sean Gordon will present the audit.
2. The Kansas Department of Commerce in partnership with Team Kansas is hosting the **To The Stars: Celebrating Kansas Businesses Awards Banquet** on **Wednesday, May 11<sup>th</sup> from 5:30 pm – 7:30 pm**, at the Topeka Country Club, located at 2700 Buchanan in Topeka, KS. *KanPak is one of the top four finalists for the Governor's Award of Excellence* and will be recognized at this event.
3. **City Commission Work Session** to be held at **noon on Friday, May 13<sup>th</sup>** in the City Manager's office, located at City Hall.
4. **City Commission Meeting** to be held **Tuesday, May 17<sup>th</sup> at 5:30 p.m.** in the Commission Chambers, located at City Hall.
5. **Friday, June 3<sup>rd</sup> at noon** there will be a **City Commission Budget Work Session with Outside Agencies** held in the Commission Chambers, located at City Hall.
6. Status update on current city projects as of April 26, 2022.

**Approved for Agenda by:**

---

Randy Frazer, City Manager



## CITY OF ARKANSAS CITY PROJECTS

as of 4/26/2022

| PROJECT                                                     | COST       | COST SHARE | TIMELINE | STATUS                                                                                                                                                                                                                                                                                                                                                                                                               |
|-------------------------------------------------------------|------------|------------|----------|----------------------------------------------------------------------------------------------------------------------------------------------------------------------------------------------------------------------------------------------------------------------------------------------------------------------------------------------------------------------------------------------------------------------|
| <b>WATER FUND</b>                                           |            |            |          |                                                                                                                                                                                                                                                                                                                                                                                                                      |
| Water Distribution Master Plan                              | \$ 43,500  | N/A        |          | <ul style="list-style-type: none"> <li>•4/6/22 –All requested information has been sent to PEC.</li> <li>•4/14/9/22 –PEC has flow testing locations determined.</li> <li>•4/18/22 –Flow testing performed, tank levels and pump flows recorded at times of flow testing.</li> <li>•PEC developing working water distribution model.</li> </ul>                                                                       |
| North Pressure Zone High Service Pump Station (1029)        | \$ 840,360 | N/A        | 02/01/22 | <ul style="list-style-type: none"> <li>•3/29/22 –Generator training and start-up.</li> <li>•3/31/22 –Controls training.</li> <li>•4/1/22 thru 4/14/22 –Painting completed, Pedrotti setting up programing, pump station operated and monitored.</li> <li>•4/15/22 – Substantial Completion.</li> <li>•4/18/22 –Punch list developed.</li> <li>•Pump Station on-line, Wildcat working on punch list items.</li> </ul> |
| <b>SEWER FUND</b>                                           |            |            |          |                                                                                                                                                                                                                                                                                                                                                                                                                      |
| Downtown Alley Reconstruction - 5th Ave to Adams Ave (1043) | \$ 335,000 | N/A        | 03/31/22 | S&O is waiting till summer and right after the CCLIP project is out to bids. Will also need to coordinate with Kansas Gas's schedule. Construction summer/fall '22                                                                                                                                                                                                                                                   |
| Kansas Ave Sewer Line Extension for Truck Stop              | \$ 356,721 | N/A        | TBD      | S&O did the survey work. On hold until the Antiquities study is done                                                                                                                                                                                                                                                                                                                                                 |



## CITY OF ARKANSAS CITY PROJECTS

as of 4/26/2022

| PROJECT                                                   | COST          | COST SHARE                    | TIMELINE        | STATUS                                                                                                                                                                                                                                                                                                                                                                        |
|-----------------------------------------------------------|---------------|-------------------------------|-----------------|-------------------------------------------------------------------------------------------------------------------------------------------------------------------------------------------------------------------------------------------------------------------------------------------------------------------------------------------------------------------------------|
| WWTP Administration Building                              | \$ 259,170    |                               |                 | <ul style="list-style-type: none"> <li>•3/1/22 –Building delivered.</li> <li>•3/2/22 –Morton putting up building.</li> <li>•3/9/22 Morton finishing up building.</li> <li>•3/11/22 Started interior work on building.</li> <li>•3/18/22 –Utilities connected this week.</li> <li>•3/26/22 –Painting to be completed and temporary SCADA cable installed this week.</li> </ul> |
| Wastewater Treatment Plant Upgrades (1025)                | \$ 12,500,000 | N/A                           | 04/26/23        | CSS Contractors are on site and have started some concrete and duct bank work and will begin doing some removal of equipment in the near future. Equipment is ordered and will begin arriving over the next several months                                                                                                                                                    |
| <b>SPECIAL HIGHWAY FUND</b>                               |               |                               |                 |                                                                                                                                                                                                                                                                                                                                                                               |
| Second and Spruce intersection replacement                |               |                               |                 | Working on the west side of the intersection. Getting ready to pour concrete in the flow line and sidewalk area first.                                                                                                                                                                                                                                                        |
| Madison Ave ( Summit to 8th) Mill & Overlay (1031)        | \$ 512,358    | 90/10 up to \$300K Reimbursed | Let<br>03/16/22 | <b>CCLIP Funds</b> - Awarded July 15,2020. In design. Submitting check plans to KDOT within next few days, project bids this summer, construction fall '22                                                                                                                                                                                                                    |
| No. Summit (Kansas Ave to Radio Ln) Mill & Overlay (1036) | \$ 910,000    | \$455K<br>\$227.5K            | Let<br>03/01/22 | <b>CDBG Funds</b> - Awarded January 26, 2021. Spend by 24 months (January 25, 2023). <b>Cost Share Program</b> Awarded. Project awarded to Person Construction for \$728,700.00 Signing contracts, and contractor (Pearson) is preparing traffic control plan. Pre-construction conference will be next month. Construction commence early June                               |



## CITY OF ARKANSAS CITY PROJECTS

as of 4/26/2022

| PROJECT                                                                 | COST       | COST SHARE                    | TIMELINE        | STATUS                                                                                                                                                                                                                                                                                                                                                                                                                                                               |
|-------------------------------------------------------------------------|------------|-------------------------------|-----------------|----------------------------------------------------------------------------------------------------------------------------------------------------------------------------------------------------------------------------------------------------------------------------------------------------------------------------------------------------------------------------------------------------------------------------------------------------------------------|
| 15th St Bridge Replacement (1042)                                       | \$ 451,491 | 90/10 up to \$150K Reimbursed | Let<br>03/31/22 | Engineer plans to finalize the plans and put together the bid documents for advertisement around the third week of May with a bid opening around the same time the following month depending on when the commissioners meet.                                                                                                                                                                                                                                         |
| <b>VARIOUS PROJECTS</b>                                                 |            |                               |                 |                                                                                                                                                                                                                                                                                                                                                                                                                                                                      |
| TEAP Study Grant E. Osage Ave., N. C St., E. Kansas Ave., N. Summit St. |            | KDOT GRANT PAYS FOR STUDY     |                 | Approved Jan 22 project has been awarded to Transystems                                                                                                                                                                                                                                                                                                                                                                                                              |
| Transportation Mater Plan<br>Transystems                                | \$ 25,000  |                               |                 | <p>Have provided •Safety Hot Spot Analysis and identified “Safety Corridors” and Areas (essentially Summit Avenue and anything within about a half a mile of a school. waiting on public input to drive next steps</p> <ul style="list-style-type: none"> <li>•Systemic crash review</li> <li>•Toolbox features – Speed tables, Three Lane sections, Two stage crossings and pedestrian refuge areas</li> <li>•Concept for 4-lane option for North Summit</li> </ul> |



## CITY OF ARKANSAS CITY PROJECTS

as of 4/26/2022

| PROJECT                             | COST       | COST SHARE | TIMELINE | STATUS                                                                                                                                                                                                                                                                                                                                                                                                                                                                                                                                                                                                                                                                                                                                                                                                                                                                                                     |
|-------------------------------------|------------|------------|----------|------------------------------------------------------------------------------------------------------------------------------------------------------------------------------------------------------------------------------------------------------------------------------------------------------------------------------------------------------------------------------------------------------------------------------------------------------------------------------------------------------------------------------------------------------------------------------------------------------------------------------------------------------------------------------------------------------------------------------------------------------------------------------------------------------------------------------------------------------------------------------------------------------------|
| CDBG Housing Renovation Grant       | \$ 300,000 |            |          | Michelle is working on the Environmental which should be done by May 31st. She has our Contractors Guidelines and Housing Plan ready except for updating the income guidelines on the Housing Plan. She has been waiting on Hud's updated income guidelines so that she can then send the Housing Plan back to us for adoption and signing and then onto KDOC for approval. This week Michelle should be getting to us the Code of Conduct, Procurement Policy and Civil Right/Fair Housing Policy for adoption and signing. Once KDOC approves our Housing Plan we can start handing out application and we will need to plan for a meeting for Call to Contractors to solicit local contractors and meeting for the Target Area to do a presentation and answer question. Michelle has sent information on Fair Housing Activities and staff will need to decide what to do for a Fair Housing Activity? |
| Truck Stop Project                  |            |            |          | Developers have the CLOMA for the flood plain and are working with the engineering and architect right now. this project is in a holding pattern until the Antiquities study is finished                                                                                                                                                                                                                                                                                                                                                                                                                                                                                                                                                                                                                                                                                                                   |
| Algonquin Kansas Antiquities survey | \$ 8,760   |            |          | Expecting to have the project finished on May 1st                                                                                                                                                                                                                                                                                                                                                                                                                                                                                                                                                                                                                                                                                                                                                                                                                                                          |



## CITY OF ARKANSAS CITY PROJECTS

as of 4/26/2022

| PROJECT                            | COST         | COST SHARE                   | TIMELINE                     | STATUS                                                                                                                                                                                                                                                                                                                                                                                                                                                                                                                                                |
|------------------------------------|--------------|------------------------------|------------------------------|-------------------------------------------------------------------------------------------------------------------------------------------------------------------------------------------------------------------------------------------------------------------------------------------------------------------------------------------------------------------------------------------------------------------------------------------------------------------------------------------------------------------------------------------------------|
| Hike/Bike Trail Phase II (1022)    | \$ 1,156,323 | 80/20<br>TA Max<br>\$840,091 | KDOT will<br>let<br>05/18/22 | Field Check Plans to KDOT. We will pay our share when KDOT goes out for bid. Advertise for construction engineering and inspection. Construction commence Summer '22.                                                                                                                                                                                                                                                                                                                                                                                 |
| Wilson Park (1020)                 | \$ 600,000   | Private                      | 04/01/22                     | Contractor will be finishing trim on the building this week, by weeks end baring weather the building will be 100% completed. Joint sealing will be completed this week as well it started last Friday the 22nd. Backfill is almost complete and will to try and get that and the little bit of grading completed later this week or the first part of next week. Contractor will be trying to prep and pour the electrical pedestal with the 2 light poles as well this week. Will try to get the pavement marking scheduled for May the 2nd or 3rd. |
| <b>Police Department</b>           |              |                              |                              |                                                                                                                                                                                                                                                                                                                                                                                                                                                                                                                                                       |
| Retail Crime Task Force            |              |                              |                              | Rolled this out to Chamber Coffee last Thursday. It involves creating a network with the business community to push out current crime issues along with education. The program will feature a quarterly in-person meeting to review current crimes & trends                                                                                                                                                                                                                                                                                           |
| Mental Health Co-Responder Program |              |                              |                              | A mental health co-responder has been hired in a joint PD & 4 County Mental Health project. MPO Tuxhorn recently travelled to Hurst Tx to ride along with their mental health unit to learn how their program works. This program should be operational this summer.                                                                                                                                                                                                                                                                                  |



## CITY OF ARKANSAS CITY PROJECTS

as of 4/26/2022

| PROJECT             | COST | COST SHARE | TIMELINE | STATUS                                                                                                                                                                                                                                                                                                                                                                                                                                                                                                                                                                                                                |
|---------------------|------|------------|----------|-----------------------------------------------------------------------------------------------------------------------------------------------------------------------------------------------------------------------------------------------------------------------------------------------------------------------------------------------------------------------------------------------------------------------------------------------------------------------------------------------------------------------------------------------------------------------------------------------------------------------|
| Cell Phone Program  |      |            |          | <p>We are working to supply officers with cell phones used while at work. They will be checked out at the beginning of shift and officers will be able to call citizens from these phones without using their personal devices. This program will also enable officers to access a mobile computer aided dispatch application that is being paid for by Cowley County Emergency Communications. The app will allow officers to see active and closed calls for service, supervisors can see what officers are busy on &amp; it gives officers the ability to access records management tools to include mugshots.</p> |
| Safe Return program |      |            |          | <p>Mental health officer is working on a project to reach out to the community and collect data on our most vulnerable populations. The program will help us quickly locate people with dementia , autism and other developmental deficiencies who have ventured away from their safe places. Collaboration &amp; coordination with the community is the primary theme.</p>                                                                                                                                                                                                                                           |
| End of School Bash  |      |            |          | <p>Numerous stakeholders have come together to host an end of school party in Wilson Park on May 14th from 11-5</p>                                                                                                                                                                                                                                                                                                                                                                                                                                                                                                   |



## CITY OF ARKANSAS CITY PROJECTS

as of 4/26/2022

| PROJECT                          | COST | COST SHARE | TIMELINE | STATUS                                                                                                                                                                                                                                                                                                                                                                                  |
|----------------------------------|------|------------|----------|-----------------------------------------------------------------------------------------------------------------------------------------------------------------------------------------------------------------------------------------------------------------------------------------------------------------------------------------------------------------------------------------|
| Hope Squad                       |      |            |          | We are currently working with USD470 & Cowley College to bring a suicide prevention program into our schools that also tackles drug & alcohol prevention, bullying, inclusion and more. The SRO & Mental Health Officer/Co-Responder will assist in being advisors for this program. Information on Hope Squad can be found at <a href="http://www.hopesquad.com">www.hopesquad.com</a> |
| <b>Fire Department</b>           |      |            |          |                                                                                                                                                                                                                                                                                                                                                                                         |
| Fire Station remodel and repairs |      |            |          | Buildings crew has started remodeling the men's shower room, the EMS supply room has been remodeled and more room as well. The roof is in the process of getting repaired and the coating on as soon as the Company can get it worked in.                                                                                                                                               |
| Pumper 55                        |      |            |          | Staff moved the tank, pump and equipment over from the newer pickup to the 2 ½ ton truck. they have been working on getting Pumper 54 completed (they just got the tank in a couple weeks ago so we could finish it) they have to build the back to mount the pump and finish painting it.                                                                                              |
| Aerial Platform truck            |      |            |          | Truck is in Springfield Missouri getting the seals and misc. work done which were found during the annual test.                                                                                                                                                                                                                                                                         |
| Gas Monitors                     |      |            |          | Department just purchased new 4 gas monitors.                                                                                                                                                                                                                                                                                                                                           |
| Uniform Shirts                   |      |            |          | Department is set up to make their own uniform shirts and has been completed for each shift. They are in the process of making some polo shirts for the crews with a goal to make a better looking shirt at an affordable price.                                                                                                                                                        |

# CITY OF ARKANSAS CITY PROJECTS

as of 4/26/2022

| PROJECT       | COST | COST SHARE | TIMELINE | STATUS                                            |
|---------------|------|------------|----------|---------------------------------------------------|
| New Ambulance |      |            |          | New Ambulance arrived in the past couple of weeks |
|               |      |            |          |                                                   |