



# City Commission Regular Meeting

Tuesday, January 02, 2024 at 6:00 PM  
Commission Chambers, 124 S Bluff, Anthony, KS 67003

---

## AGENDA

### OPENING

- Welcome / Call to Order
- Invocation / Pledge of Allegiance
- Roll Call
- Approval of Agenda

### PUBLIC COMMENT

*Public Comment allows the public an opportunity to address the City Commission. There is a five minute per person limit on public comments.*

### CONSENT AGENDA

- [1.](#) Approve Regular Meeting Minutes of December 19, 2023
- [2.](#) Approve Special Meeting Minutes of December 29, 2023
- [3.](#) Appropriation Ordinance No. 3181 \$116,370.46
- [4.](#) Approve 01.02.2024 Payroll \$57,146.46
5. Appoint Clay Shelton to the Fire Department.
- [6.](#) Approve December 2023 Court Report
7. Approve Recommendation of Wayne Dennis Committee to appoint Brad Davis to serve a full term until November 2026.

### PUBLIC HEARINGS - NONE

### REGULAR BUSINESS

- [8.](#) Approve Service Quote for John Deer 6115 Tractor #70
- [9.](#) Approve to Bid Out Replacement Meter for City Water Well #4
10. Old Shelter at the Former Dirt Track
11. Fire Department Funds

### STAFF REPORTS

[12.](#) Chief of Police report

**EXECUTIVE SESSION - NONE**

**ADJOURNMENT**

---

Standing Committees:

- |   |                                      |
|---|--------------------------------------|
| a. Commissioner of Finance:                   | Jan Lanie – Sherrie Eaton (Vice)     |
| b. Commissioner of Utilities Depts.:          | Kenny Hodson Jr. – Jan Lanie (Vice)  |
| c. Commissioner of Parks, Police, Fire Dept.: | Sherrie Eaton – Eric Smith (Vice)    |
| d. Commissioner of Street Dept., Airport:     | Eric Smith – Kenny Hodson Jr. (Vice) |



# City Commission Regular Meeting

Tuesday, December 19, 2023 at 6:00 PM  
Commission Chambers, 124 S Bluff, Anthony, KS 67003

## MINUTES

### OPENING

- Welcome / Call to Order
- Invocation / Pledge of Allegiance
- Roll Call

Present:

Mayor Gregory Cleveland  
Commissioner Sherrie Eaton  
Commissioner Howard Hatfield  
Commissioner Jan Lanie  
Commissioner Eric Smith

City Administrator Cyndra Kastens, Superintendent Randy Moore, Police Chief Kenny Hodson, Kari O'Riley and Shonda Larson from Harper County, and Rebeccas Tarnow and Don Atha.

- Approve Agenda

Mayor Cleveland made a motion to approve the agenda as presented. Commissioner Lanie seconded. Motion carried 5-0.

### PUBLIC COMMENT - NONE

### CONSENT AGENDA

1. Approve December 5, 2023 Regular Meeting Minutes
2. Appropriation Ordinance No 3180 \$215,589.25
3. Approve 12.19.2023 Payroll \$58,849.87
4. Approval to go out for Bid to Repair High Service Pump #1 (East)
5. Reappoint Kanza Bank, Bank of the Plains and Bank of Commerce as Official City Banks for 2024
6. Appoint Anthony Republican as Official City Newspaper for 2024
7. 2024 Cereal Malt Beverage Renewals

## 8. Resolution No. 1140 - Annual GAAP Waiver

**RESOLUTION NO. 1140**

**WHEREAS**, the City of Anthony, Kansas has determined that the financial statements and financial reports for the year end 2024 will be prepared in conformity with the requirements of K.S.A. 75-1120a(c) finding financial statements and financial reports to be prepared in conformity with the requirements of subsection (a) are not relevant to the requirements of the cash basis and budget laws of this state and are of no significant value to the City Commission or the members of the general public of the City of Anthony and

**WHEREAS**, there are no revenue bond ordinances or other ordinances or resolutions of the municipality which require financial statements and financial reports to be prepared in conformity with K.S.A. 75-1120a(a) for the year end 2024.

**NOW, THEREFORE BE IT RESOLVED**, by the City Commission of the City of Anthony, Kansas, in regular meeting duly assembled this 19th day of December 2023 that the City Commission requests the Director of Accounts and Reports to waive the requirements of K.S.A. 75-1120a(a) as they apply to the City of Anthony for the year ended 2024.

**BE IT FURTHER RESOLVED** that the City Commission shall cause the financial statements and financial reports of the City of Anthony to be prepared on the basis of cash receipts and disbursements as adjusted to show compliance with the cash basis and budget laws of this State.

**ADOPTED** this 19th day of December, 2023.

## 9. Resolution No. 1141 - Annual Approval of Permit Fee Schedule

Mayor Cleveland asked if any items should be removed from the consent agenda for discussion. Mayor Cleveland made a motion to approve the consent agenda minus items 7 & 9 to be discussed after the RHID. Motion seconded by Commissioner Smith. Motion carried 5-0.

**PUBLIC HEARINGS - NONE**10. **Public Hearing to Establish a Re-Investment Housing District and Adopt RHID Plan at Sunrise Additions**

Mayor Cleveland opened the Public Hearing for the Reinvestment Housing Incentive District creation. The City Administrator presented the details of the RHID plan. Members of the public were given the opportunity to ask questions. One question was asked and answered about housing. Mayor Cleveland then closed the public hearing.

**REGULAR BUSINESS**11. **Ordinance No. G-2872 Establishment of Re-Investment Housing District and Plan**

Mayor Cleveland made a motion to approve Ordinance No. G-2872 Creation of Sunrise 2nd Addition Reinvestment Housing District. Motion seconded by Commissioner Eaton. A roll call vote was taken: Mayor Cleveland – Yea, Commissioner Eaton – Yea, Commissioner Hatfield – Nay, Commissioner Lanie – Yea, Commissioner Smith – Yea. Motions carried 4-1.

7. **2024 Cereal Malt Beverage Renewals**

The cereal malt beverage renewal licenses were presented for the following applicants:  
**ANTHONY GOLF CLUB**

**CLASEN INC.: d.b.a. Gene’s Heartland Foods**

**DENNIS DODGEN: d.b.a. Jack’s Service Station**

**KRISTY CALVERT: d.b.a. Kristy’s Kafe**

**SHEPHERD OIL COMPANY: d.b.a. Shepherd’s**

**DOUG ASPER: d.b.a. The Sporting Zone**

**DG RETAIL, LLC: d.b.a. Dollar General Store #581**

**FAMILY DOLLAR LLC: d.b.a. Family Dollar #33267**

A motion was made to approve the 2024 Cereal Malt Beverage License Renewals as presented contingent upon successfully passing background checks.

Motion made by Mayor Cleveland. Seconded by Commissioner Eaton.

Voting Yea: Mayor Cleveland, Commissioner Eaton, Commissioner Hatfield, Commissioner Lanie, and Commissioner Smith. Motion carried 5-0.

9. **Resolution No. 1141 - Annual Approval of Permit Fee Schedule**

**RESOLUTION NO. 1141**

A RESOLUTION OF THE CITY COMMISSION  
OF THE CITY OF ANTHONY, KANSAS  
ESTABLISHING THE CITY’S 2024 PERMIT  
FEE SCHEDULE

**WHEREAS**, it is beneficial for the City of Anthony to have a current and updated City Permit Fee Schedule.

**NOW, THEREFORE BE IT RESOLVED**, by the City Commission of the City of Anthony, Kansas, in regular meeting duly assembled this 19th day of December, 2023: As follows:

Section 1. The Anthony City Commission hereby establishes and adopts the formalized 2024 City Permit Fee Schedule which is attached hereto as Resolution Exhibit A and incorporated herein by this reference.

Section 2. The 2024 City Permit Fee Schedule shall be effective beginning January 1, 2024 and remain in effect until a resolution is passed replacing this resolution. All previous resolutions and permit fee schedules are repealed and replaced by this resolution.

After discussion, a motion was made to approve Resolution No. 1141 as presented.

Motion made by Mayor Cleveland. Seconded by Commissioner Smith.

Voting Yea: Mayor Cleveland, Commissioner Eaton, Commissioner Lanie, and Commissioner Smith. Voting Nay: Commissioner Hatfield. Motion carried 4-1.

12. **Request to Waive Special Assessment 402 S Anthony - Creighton Cullop**

The City Administrator informed the Commission that Mr. Cullop was not present because he no longer needed to request the city to waive these fees. The Commission then confirmed the continued direction of the City Administrator toward research and determination of the goal to no longer remove special assessments as assessed by the City of Anthony.

13. **Approve Wayne Dennis Committee Recommendation \$2,250 to Art Center for Grant Match on Hwy Mural**

A motion was made to approve the Wayne Dennis Committee recommendation of \$2,250 to the Arts Center for grant match on the highway mural.

Motion made by Commissioner Eaton. Seconded by Commissioner Lanie.

Voting Yea: Mayor Cleveland, Commissioner Eaton, Commissioner Hatfield, Commissioner Lanie, and Commissioner Smith. Motion carried 5-0.

14. **Metal Art in Right of Way**

A great discussion was held regarding the metal art recently mounted into the public right-of-way at 102 W Main. At the conclusion, the Commission directed the following:

1. Due to public safety, remove the metal art.
2. Commissioner Hatfield work with Superintendent Moore to determine an alternate plan and report back to the City Commission for approval.
3. Review the First Impressions report in January and discuss the metal art initiative again after all of these items have been concluded.

15. **Old Shelter at Former Dirt Track**

Administrator Kastens sought direction as to whether the Commission would like to relocate or put out to bid the shelter at the old dirt track. The Commission guided the Administrator to have city staff take it down and demo the shelter.

16. **SEED Grant Update**

The City Administrator updated the Commission on the SEED grant and presented them with predesigned options to quickly select a winter banner since there were enough funds left in the grant to pay for those and 15 more main banners before the grant deadline. The Commission selected a design.

17. **Anthony Lake Boat Ramp**

The City Administrator sought an update from the Commission on the direction for the boat ramp. The Commission guided the Administrator to put the project back out to bid.

**STAFF REPORTS**

18. Administrator Report

The Administrator provided a written report on the following: staffing, highway mural, airport, BASE grant, boat ramp, FEMA Floodplain map revision, billboards, and the city christmas party.

19. Superintendent Report

The superintendent provided a report on the following activity: front office assistance, tire quote, permits, picking up a part in El Dorado, and all department activities.

20. Chief of Police Report

The Police Chief provided a report on the following police department activities:

We talked to several people about health notices

We arrested Robert Lambert for pedestrian under the influence

We investigated a domestic disturbance in the 100 block of N. Santa Fe and arrested Kelsey Lear for domestic battery

We investigated a domestic disturbance in the 900 block of E. Spring and turned the case over to the County Attorney for possible charges

We investigated a criminal damage to property case in the 100 block of E. Main

**EXECUTIVE SESSION - NONE**

**ADJOURNMENT**

Mayor Cleveland made a motion to adjourn the meeting. Commissioner Lanie seconded. Motion carried 5-0.

---

Gregory Cleveland, Mayor

---

Cyndra Kastens, City Clerk/Administrator

---





## City Commission Special Meeting

Friday, December 29, 2023 at 9:00 AM  
Commission Chambers, 124 S Bluff, Anthony, KS 67003

### MINUTES

#### CALL TO ORDER

#### ROLL CALL

**PRESENT:** Mayor Gregory Cleveland, Commissioner Sherrie Eaton, Commissioner Howard Hatfield, and Commissioner Eric Smith.

**City Administrator Cyndra Kastens, Police Chief Kenny Hodson.**

#### ABSENT:

**Commissioner Jan Lanie**

#### PUBLIC COMMENT - NONE

#### ITEMS OF BUSINESS

1. Approve Submission of "Technical Assistance Grant" through the Kansas Water Office for Engineering Services and Materials for the City of Anthony Water Main

Administrator Kastens presented the Kansas Water Office Technical Assistance Grant as the opportunity to secure engineering, corrective options, opinions of cost, and installation of a new valve and pressure transducer on the 16" city main. There is no match to this \$102,500 grant.

A motion was made to approve submission of the Technical Assistance Grant through the Kansas Water Office and authorize the City Administrator to execute all documents necessary for the application process.

Motion made by Commissioner Smith, Seconded by Commissioner Eaton.

Voting Yea: Mayor Cleveland, Commissioner Eaton, Commissioner Hatfield, Commissioner Smith. Motion carried 4-0.

2. Approve Submission of "Section 40101(d): Preventing Outages & Enhancing the Resilience of the Electric Grid Grant" for Alley Circuit Reconstruction

Administrator Kastens presented the Kansas Coporation Commission Section 40101(d) Grant to aid in the cost to replace 1600' of feeder line for the Springfield/Lincoln and 2300' of feeder

line for the Kansas/Bluff alley projects, and to replace the four reclosures at the in-town switching station. The \$402,530 grant would require a \$131,155.36 match.

A motion was made to approve submission of the 40101(d) Electric Grid Grant, committing a match of \$131,155.36 from Capital Electric, and authorize the City Administrator to apply to the Build Kansas Fund to cover the city portion of the match. I further motion to authorize the City Administrator to execute all documents necessary for application of both programs.

Motion made by Commissioner Eaton, Seconded by Mayor Cleveland.  
Voting Yea: Mayor Cleveland, Commissioner Eaton, Commissioner Hatfield, Commissioner Smith. Motion Carried 4-0.

**ADJOURNMENT**

A motion was made to adjourn the meeting.

Motion made by Mayor Cleveland, Seconded by Commissioner Smith.  
Voting Yea: Mayor Cleveland, Commissioner Eaton, Commissioner Hatfield, Commissioner Smith.  
Motion carried 4-0.

---

Gregory Cleveland, Mayor

---

Cyndra Kastens, City Clerk/Administrator

**BALANCE SHEET**  
**CALENDAR 1/2024, FISCAL 1/2024**

ACCOUNT NUMBER	ACCOUNT TITLE	PTD BAL.	YTD BAL
01-00-0010	GENERAL OPERATING	19,161.11-	978,797.08
02-00-0010	WATER	17,032.22-	781,594.69
03-00-0010	ELECTRIC	37,547.36-	2,439,412.00
04-00-0010	SALES TAX & STATE FEES		37,820.86
05-00-0010	SEWAGE DISPOSAL	8,955.73-	565,819.11
10-00-0010	EMP INSURANCE/BENEFIT	38,758.30-	309,133.97
12-00-0010	AIRPORT		179,406.02
14-00-0010	INDUSTRIAL DEVELOPMENT		20,274.19
16-00-0010	SERVICE DEPOSIT		86,729.28
17-00-0010	SPECIAL STREETS & HIGHWAY		259,692.27
18-00-0010	PUBLIC RELIEF		24,038.00
19-00-0010	WATER UTILITY RESERVE		242,981.31
21-00-0010	WTF LOAN 206J		95,624.71
23-00-0010	WATER DEBT SVC RESERVE S2013		149,904.65
24-00-0010	BOND & INTEREST		9,059.07
26-00-0010	RECREATION COMMISSION	637.31-	51,802.10
29-00-0010	RECREATION		3,422.30
30-00-0010	MUNICIPAL EQUIPMENT RESERVE		126,039.81
32-00-0010	SPECIAL PARKS & RECREATION		32,727.18
34-00-0010	CAPITAL IMPROVEMENT		3,458,516.32
37-00-0010	GO BONDS S2010 POOL		13,100.79
40-00-0010	ELECTRIC UTILITY RESERVE		1,559,835.43
41-00-0010	EL UTIL S2017 REV BOND		2,266,196.79
43-00-0010	EL UTIL S2017 BOND RESERVE		214,897.50
45-00-0010	SEWER RESERVE		155,000.00
47-00-0010	WILDLIFE AND PARKS GRANT		471,455.11
50-00-0010	WAYNE DENNIS INVESTMENT FUND		750,141.35
54-00-0010	DEBT RES. WATER 2013		199,101.69
61-00-0010	MUNICIPALITIES FIGHT ADDICTION		6,171.04
81-00-0010	WASTEWATER LAGOON CLEANING		182,600.00
82-00-0010	WATER/EQUIPMENT REPLACEMENT		120,962.03
83-00-0010	ELECTRIC/EQUIP REPLACEMENT		2,185,353.35
85-00-0010	SEWER/EQUIPMENT REPLACEMENT		81,454.04
89-00-0010	TRANS GUEST APPROVED		.27
95-00-0010	FIRE DEPT CLOSING CK 612		12,674.02
96-00-0010	WAYNE DENNIS FUNDS		11,622.37
97-00-0011	DT REVIT. REVOLVING LOAN		.56
98-00-0010	TRANSIENT GUEST TAX		2,212.62
		=====	=====
	PROOF	122,092.03-	18,085,573.88
		=====	=====

**CLAIMS REPORT**  
 Check Range: 12/21/2023- 1/03/2024

#3181

VENDOR NAME	REFERENCE	AMOUNT	VENDOR TOTAL	CHECK#	CHECK DATE
GENERAL OPERATING					
CITY OF ANTHONY	PD MAILING		489.23	12498672	12/30/23
ECOWATER SYSTEMS	PD WATER		9.00	51176	12/29/23
ELLIOTT EQUIPMENT CO.	#42 SWEEPER BROOMS		1,258.26	51177	12/29/23
FIRST WIRELESS INC	M6 BATTERY		42.00	51178	12/29/23
BRETT GATES	BOOT REIMB		150.00	51179	12/29/23
GREAT-WEST FINANCIAL	1/2/24		498.15	12498680	1/02/24
HARPER COUNTY TREASURER	SUNRISE 2ND WEST 16 RESIDENTIA		10,821.76	51162	12/21/23
THE HON COMPANY	PD STORAGE CABNET		682.32	51180	12/29/23
IRS	1/2/24 PR		4,370.05	12498679	1/02/24
KHP TROOP F HEADQUARTERS	MVE FORMS		100.00	51194	1/03/24
KANSAS MUNICIPAL JUDGES ASSOC	2024 DUES		25.00	51195	1/03/24
KANSAS PAYMENT CENTER	1/2/24 PR		207.69	12498677	1/02/24
KPERS	1/2/24 PR		3,044.68	12498681	1/02/24
KS DEPT OF REV-WITHHOLDING	1/2/24 PR		770.27	12498678	1/02/24
MAISEY PRO	DEC SVC		33.00	51188	12/29/23
MANHATTANLIFE ASSURANCE COMP	CANCER INS		1.69	51196	1/03/24
NAPA AUTO PARTS ANTHONY	#52 BATTERY/VALVE		838.26	51184	12/29/23
NEW YORK LIFE	EMP LIFE INS		4.60	51197	1/03/24
NEWBERRY FAMILY AUTO	#52 UHF		46.30	51185	12/29/23
SOUTH CENTRAL WIRELESS	PD PHONE		406.92	51186	12/29/23
TERMINIX PROCESSING CENTER	DEC HALL PEST CONTROL		85.56	51189	12/29/23
VERIZON WIRELESS	PD CELL		41.46	51198	1/03/24
VISION SERVICE PLAN	JANUARY		156.92	12498673	1/02/24
WAXIE SANITARY SUPPLY	HALL PAPER TOWELS		208.63	51190	12/29/23
WEST STREET BODY & FENDER REP	#80 BUMPER REPAIR		531.05	51191	12/29/23

01 GENERAL OPERATING TOTAL 24,822.80

WATER					
AMAZON CAPITAL SERVICES	SHOP PAPER TOWELS		33.31	51171	12/29/23
ANSWER PRO	DECEMBER ANSWERING SERVICE		95.00	51172	12/29/23
CITY OF ANTHONY	WATER SAMPLE		64.78	12498672	12/30/23
CITY OF ANTHONY	ELECTRIC REIMB NOV 2023	946.60		51174	12/29/23
CITY OF ANTHONY	REIMB JAN BCBS	7,433.38	8,379.98	51192	1/03/24
CORE & MAIN LP	GASKET/INSULATOR		272.46	51175	12/29/23
GREAT-WEST FINANCIAL	1/2/24		82.95	12498680	1/02/24
HARPER COUNTY TREASURER	DRIVING RANGE		6,126.11	51162	12/21/23
INNOVATIVE AUTOMATION	REMOTE SUBSCRIPTION FOR SCADA		520.00	51181	12/29/23
IRS	1/2/24 PR		1,732.15	12498679	1/02/24
JCI INDUSTRIES, INC	CHLORINE PUMPS @ PLANT		1,405.68	51182	12/29/23
KPERS	1/2/24 PR		1,268.87	12498681	1/02/24
KS DEPT OF REV-WITHHOLDING	1/2/24 PR		290.12	12498678	1/02/24
MAISEY PRO	DEC SVC		33.00	51188	12/29/23
MANHATTANLIFE ASSURANCE COMP	CANCER INS		23.62	51196	1/03/24
MUNICIPAL SUPPLY, INC	6" MAIN COUPLERS		1,428.90	51183	12/29/23
MUTUAL OF OMAHA	JANUARY LIFE INS		45.04	12498675	1/02/24
NAPA AUTO PARTS ANTHONY	#5 STARTER/GAS CAN/#11 EXT LIF		214.89	51184	12/29/23
NEW YORK LIFE	EMP LIFE INS		14.70	51197	1/03/24
PITNEY BOWES INC	ADDED POSTAGE		125.00	12498671	12/30/23
SOUTH CENTRAL WIRELESS	SHOP LINES		264.75	51186	12/29/23
TERMINIX PROCESSING CENTER	DEC OFFICE PEST CONTROL		42.33	51189	12/29/23
VERIZON WIRELESS	WATER CELL		106.74	51198	1/03/24
VISION SERVICE PLAN	JANUARY		54.65	12498673	1/02/24



**CLAIMS REPORT**  
 Check Range: 12/21/2023- 1/03/2024

VENDOR NAME	REFERENCE	AMOUNT	VENDOR TOTAL	CHECK#	CHECK DATE
02 WATER TOTAL			22,625.03		
ELECTRIC					
AMAZON CAPITAL SERVICES	SHOP PAPER TOWELS		52.47	51171	12/29/23
ANSWER PRO	DECEMBER ANSWERING SERVICE		95.00	51172	12/29/23
CARBANC AUTO SALES, INC	1/02/24 PR		357.83	51193	1/03/24
CITY OF ANTHONY	OFFICE MAILING		23.13	12498672	12/30/23
CITY OF ANTHONY	REIMB JAN BCBS		9,308.30	51192	1/03/24
GREAT-WEST FINANCIAL	1/2/24		473.64	12498680	1/02/24
HARPER COUNTY TREASURER	POWER PLANT RENTAL HOUSE+LAND		1,294.25	51162	12/21/23
IRS	1/2/24 PR		5,499.37	12498679	1/02/24
KPERS	1/2/24 PR		3,828.22	12498681	1/02/24
KS DEPT OF REV-WITHHOLDING	1/2/24 PR		1,013.64	12498678	1/02/24
LIBERTY NATIONAL	JANUARY		107.08	12498676	1/02/24
MAISEY PRO	DEC SVC		51.00	51188	12/29/23
MANHATTANLIFE ASSURANCE COMP	CANCER INS		98.09	51196	1/03/24
MUTUAL OF OMAHA	JANUARY LIFE INS		85.09	12498675	1/02/24
NAPA AUTO PARTS ANTHONY	#11 EXT LIFE/#19 CLEANER		45.69	51184	12/29/23
NEW YORK LIFE	EMP LIFE INS		24.27	51197	1/03/24
PITNEY BOWES INC	ADDED POSTAGE		250.00	12498671	12/30/23
SOUTH CENTRAL WIRELESS	OFFICE LINES		428.29	51186	12/29/23
TERMINIX PROCESSING CENTER	DEC OFFICE PEST CONTROL		42.33	51189	12/29/23
VERIZON WIRELESS	ELEC CELL		55.28	51198	1/03/24
VISION SERVICE PLAN	JANUARY		175.24	12498673	1/02/24
03 ELECTRIC TOTAL			23,308.21		
SEWAGE DISPOSAL					
AMAZON CAPITAL SERVICES	SHOP PAPER TOWELS		33.31	51171	12/29/23
CITY OF ANTHONY	OFFICE MAILING		23.12	12498672	12/30/23
CITY OF ANTHONY	ELECTRIC REIMB NOV 2023	269.77		51174	12/29/23
CITY OF ANTHONY	REIMB JAN BCBS	2,460.23	2,730.00	51192	1/03/24
GREAT-WEST FINANCIAL	1/2/24		31.47	12498680	1/02/24
HARPER COUNTY TREASURER	SEWER LAGOONS & DIRT TRACK		326.96	51162	12/21/23
IRS	1/2/24 PR		1,116.35	12498679	1/02/24
KPERS	1/2/24 PR		869.22	12498681	1/02/24
KS DEPT OF REV-WITHHOLDING	1/2/24 PR		170.26	12498678	1/02/24
MAISEY PRO	DEC SVC		33.00	51188	12/29/23
MANHATTANLIFE ASSURANCE COMP	CANCER INS		9.04	51196	1/03/24
MUTUAL OF OMAHA	JANUARY LIFE INS		12.33	12498675	1/02/24
NAPA AUTO PARTS ANTHONY	#5 STARTER/GAS CAN		149.16	51184	12/29/23
NEW YORK LIFE	EMP LIFE INS		6.89	51197	1/03/24
PITNEY BOWES INC	ADDED POSTAGE		125.00	12498671	12/30/23
TERMINIX PROCESSING CENTER	DEC OFFICE PEST CONTROL		42.34	51189	12/29/23
VERIZON WIRELESS	SUPER'S CELL		13.82	51198	1/03/24
VISION SERVICE PLAN	JANUARY		54.50	12498673	1/02/24
05 SEWAGE DISPOSAL TOTAL			5,746.77		
EMPLOYEE BENEFIT					
BCBS OF KANSAS	JANUARY 2023		27,677.76	12498674	1/02/24
CITY OF ANTHONY	REIMB JAN BCBS		7,623.21	51192	1/03/24
MUTUAL OF OMAHA	JANUARY LIFE INS		80.04	12498675	1/02/24

**CLAIMS REPORT**  
 Check Range: 12/21/2023- 1/03/2024

VENDOR NAME	REFERENCE	AMOUNT	VENDOR TOTAL	CHECK#	CHECK DATE
DALTON SEYB	HRA PAYOUT 23/24 DEDUCTIBLE		1,500.00	51187	12/29/23
	10 EMPLOYEE BENEFIT TOTAL		36,881.01		
AIRPORT					
CITY OF ANTHONY	ELECTRIC REIMB NOV 2023		106.50	51174	12/29/23
HARPER COUNTY TREASURER	AIRPORT LAND		279.46	51162	12/21/23
SOUTH CENTRAL WIRELESS	AIRPORT LINE		46.86	51186	12/29/23
	12 AIRPORT TOTAL		432.82		
INDUSTRIAL DEVELOPMENT					
HARPER COUNTY TREASURER	NE CORNER GARFIELD & LL&G		169.76	51162	12/21/23
	14 INDUSTRIAL DEVELOPMENT TOTAL		169.76		
RECREATION COMMISSION					
CITY OF ANTHONY	ELECTRIC REIMB NOV 2023		7.90	51174	12/29/23
IRS	1/2/24 PR		84.70	12498679	1/02/24
VERIZON WIRELESS	REC CELL		41.46	51198	1/03/24
	26 RECREATION COMMISSION TOTAL		134.06		
WAYNE DENNIS FUNDS					
THE ARTS CENTER INC	HWY MURAL		2,250.00	51173	12/29/23
	96 WAYNE DENNIS FUNDS TOTAL		2,250.00		
	Accounts Payable Total		116,370.46		

# CLAIMS REPORT CLAIMS FUND SUMMARY

FUND	NAME	AMOUNT
01	GENERAL OPERATING	24,822.80
02	WATER	22,625.03
03	ELECTRIC	23,308.21
05	SEWAGE DISPOSAL	5,746.77
10	EMPLOYEE BENEFIT	36,881.01
12	AIRPORT	432.82
14	INDUSTRIAL DEVELOPMENT	169.76
26	RECREATION COMMISSION	134.06
96	WAYNE DENNIS FUNDS	2,250.00
-----		
	TOTAL FUNDS	116,370.46

PRUPDT00  
07.14.22

Fri Dec 29, 2023 9:57 AM  
PAID THROUGH 12/24/2023  
CALENDAR 1/2024, FISCAL 1/2024 DATES 12/24/2023 -- 1/02/2024

City of Anthony KS  
COST CENTER REPORT

OPER: JD  
JRNL 4102  
FIRST PAY OF MONTH

PAGE

Item 4.

C CTR DESCRIPTION	REG HRS	OT HRS	VAC HRS	SCK HRS	TOT HRS	REG AMT	OT AMT	VAC AMT	SCK AMT	TOT AMT	DEDUCTIONS
101 GEN. - ADM.	20.60	.00	.00	.00	24.00	1444.33	.00	.00	.00	1515.27	330.86
102 POLICE	483.60	.00	.00	.00	500.00	9921.60	.00	.00	.00	10233.16	1403.64
104 STREET	232.50	.00	.00	.00	320.00	4515.43	.00	.00	.00	6199.61	516.68
105 GEN-ZONING	.00	.00	.00	.00	.00	481.02	.00	.00	.00	481.02	.00
230 WATER-LAKE	75.00	.00	.00	.00	80.00	1186.50	.00	.00	.00	1265.60	75.94
231 WATER-PRODUCTIO	23.00	.00	.00	.00	23.00	481.10	.00	.00	.00	481.10	.00
232 WATER-DISTRIBUT	225.18	.00	.00	.00	247.20	2189.04	.00	.00	.00	2614.30	555.71
233 WATER-COMM& GEN	56.84	.00	.00	.00	85.35	2496.27	.00	.00	.00	3027.52	.00
331 ELECTRIC-PROD	495.00	.00	.00	.00	576.00	6497.95	.00	.00	.00	8594.00	848.38
332 ELEC-DISTRIBUTI	526.39	.00	.00	.00	605.60	7067.78	.00	.00	.00	9281.95	1542.48
333 ELECTRIC-COMM	68.91	.00	.00	.00	114.15	4698.50	.00	.00	.00	5510.39	203.83
533 SEWER-COMM & GE	14.55	.00	.00	.00	32.00	769.35	.00	.00	.00	1067.54	.00
534 SEWER-TREATMENT	322.68	.00	.00	.00	336.20	3929.43	.00	.00	.00	4170.46	.00
2601 REC - GEN	30.75	.00	.00	.00	30.75	553.50	.00	.00	.00	553.50	.00
5102 OT GEN POLICE	.00	20.50	.00	.00	20.50	.00	646.15	.00	.00	646.15	.00
5232 OT WATER DIST	.00	13.00	.00	.00	13.00	.00	482.79	.00	.00	482.79	.00
5233 OT WA COMM/GEN	.00	5.75	.00	.00	5.75	.00	193.20	.00	.00	193.20	.00
5331 OT ELEC PROD	.00	5.50	.00	.00	5.50	.00	239.92	.00	.00	239.92	.00
5332 OT ELEC DIST	.00	6.00	.00	.00	6.00	.00	258.48	.00	.00	258.48	.00
5534 OT SEWER TREAT	.00	7.00	.00	.00	7.00	.00	259.87	.00	.00	259.87	.00
6102 SHIFT GEN POLIC	.00	.00	.00	.00	141.25	.00	.00	.00	.00	70.63	.00
99999 DISTRIBUTED	.00	.00	.00	.00	.00	.00	.00	.00	.00	.00	410.01
TOTAL	2575.00	57.75	.00	.00	3173.25	46231.80	2080.41	.00	.00	57146.46	5887.53



### COURT REPORTING CASE REPORT

OFFN DATES: 12/01/2023-12/28/2023

FOR OFFICER CODES: ALEBTTOT

CASE NO	DEFENDANT'S NAME OFFICER'S NAME	TICKET NO	CRT DATE OFN DATE	FINE OFFENSE DESC	CRT COST	OFFN FEE	ACTN FEE	CASE TOTL	AMT PAID LST PYDT	AMT DUE
202300139	ANDERSON, RONNIE L LEDEZMA ALEX	4785	12/26/23 12/13/23	30.00 SPEEDING 10 MPH OVER	74.50	23.50	70.00	198.00	198.00 12/22/23	.00

=====

-----  
 REPORT TOTALS           198.00       198.00       .00  
 -----



## Inspection Summary

### 6115 D Tractor

Serial #L06715D539055      Warranty End Date: 01/01/01  
 Stock #      PowerGard Type: None  
 Inspection Date: 12/19/23      PowerGard End Date: 01/01/01  
 Repair Order#:      Engine Hours: 5757

Needs Replaced: **19**  
 Recommended: **0**  
 Approved: 19  
 Declined: 0

Total Parts: **\$4,220.00**  
 Total Labor: **\$5,074.51**  
**Total Parts & Labor: \$9,294.51**

Inspection Cost: **\$0.00**

Total Warranty Estimate: **\$0.00**

\*Subject to warranty approval process

**Grand Total: \$9,294.51**

### : CITY OF ANTHONY

PO BOX 504      **Technician**  
 ANTHONY, KS 67003      Tateyn Rieger  
 h:  
 m:

Acct #: 127272

\*Note: tax, service accessories, welding, paint and repairs with no estimated cost are not included in quote.

**Legend**    = Parts    = Labor    = Total    = Warranty

### Approved

Needs Replaced			
\$4,220.00	\$5,074.51	\$9,294.51	\$0.00
Recommended			
\$0.00	\$0.00	\$0.00	\$0.00
Totals			
\$4,220.00	\$5,074.51	\$9,294.51	\$0.00

### Declined

Needs Replaced			
\$0.00	\$0.00	\$0.00	\$0.00
Recommended			
\$0.00	\$0.00	\$0.00	\$0.00
Totals			
\$0.00	\$0.00	\$0.00	\$0.00

6 0 CAB		\$725.00	\$1,665.02	\$2,390.02	\$0.00
Steering Column	Declined <input type="checkbox"/> Approved <input checked="" type="checkbox"/>	Parts Estimate	Labor Estimate	Total Estimate	Warranty
<b>updated</b> Steering wheel - Remove & Install Technician Comments:Steering column does not stay up as it should.	<input type="checkbox"/> <input checked="" type="checkbox"/>	\$120.00 Qty: 2	\$179.63 Job Code: <b>6115D/4309/10</b>	\$299.63	<input type="checkbox"/>
Lights - All Outside Lights & Warning Lights	Declined <input type="checkbox"/> Approved <input checked="" type="checkbox"/>	Parts Estimate	Labor Estimate	Total Estimate	Warranty
<b>updated</b> Halogen bulb (each) - Remove & Install Technician Comments:LH tail light/turn signal does not work and is missing cover. Front LH warning light on roof is missing cover.	<input type="checkbox"/> <input checked="" type="checkbox"/>	\$175.00 Qty: 4	\$379.98 Job Code: <b>6115D/1406LGT/E/10</b>	\$554.98	<input type="checkbox"/>
<b>updated</b> Work lights - Remove & Install Technician Comments:Front roof lights do not work.	<input type="checkbox"/> <input checked="" type="checkbox"/>	\$230.00 Qty: 2	\$379.98 Job Code: <b>6115D/1406/FTH/10</b>	\$609.98	<input type="checkbox"/>

Windows	Declined	Approved	Parts Estimate	Labor Estimate	Total Estimate	Warranty
<b>updated</b> Right Hand window seal - Remove & Install Technician Comments:LH seal also.	<input type="checkbox"/>	<input checked="" type="checkbox"/>	☞ \$70.00 Qty: 1	🔧 \$414.53 Job Code: 6115D/7320/DWS/R/10	💰 \$484.53	<input type="checkbox"/>
<b>updated</b> Rear window gas cylinder (each) - Remove & Install	<input type="checkbox"/>	<input checked="" type="checkbox"/>	☞ \$115.00 Qty: 2	🔧 \$196.90 Job Code: 6115D/7374/SCK/10	💰 \$311.90	<input type="checkbox"/>
<b>updated</b> Rear window lock lever - Remove & Install	<input type="checkbox"/>	<input checked="" type="checkbox"/>	☞ \$15.00 Qty: 1	🔧 \$114.00 Job Code: 6115D/7374/LK/10	💰 \$129.00	<input type="checkbox"/>

**1 0 CHASSIS** ☞ \$500.00 🔧 \$252.17 💰 \$752.17 🛡️ \$0.00

Chassis Electrical System	Declined	Approved	Parts Estimate	Labor Estimate	Total Estimate	Warranty
<b>updated</b> Battery - Remove & Install Technician Comments:Battery only has 1039 CCA and should have 1400. Battery tester says to replace.	<input type="checkbox"/>	<input checked="" type="checkbox"/>	☞ \$500.00 Qty: 1	🔧 \$252.17 Job Code: 6115D/1401/10	💰 \$752.17	<input type="checkbox"/>

**3 0 POWERTRAIN** ☞ \$1,950.00 🔧 \$1,784.20 💰 \$3,734.20 🛡️ \$0.00

MFWD Front Axle	Declined	Approved	Parts Estimate	Labor Estimate	Total Estimate	Warranty
<b>updated</b> Drive shaft (MFWD)- Recondition Technician Comments:Replace Front and rear seals and u joints.	<input type="checkbox"/>	<input checked="" type="checkbox"/>	☞ \$750.00 Qty: 1	🔧 \$808.33 Job Code: 6115D/3259/MFW/20	💰 \$1,558.33	<input type="checkbox"/>
<b>updated</b> Steering Steering cylinder - Recondition Technician Comments:Steering cylinder on RH side is leaking. Also ball joints are worn out on both sides.	<input type="checkbox"/>	<input checked="" type="checkbox"/>	☞ \$1,200.00 Qty: 2	🔧 \$690.88 Job Code: 6115D/4303/20	💰 \$1,890.88	<input type="checkbox"/>
<b>updated</b> Toe in - Adjust Technician Comments:Front tire wear is uneven.	<input type="checkbox"/>	<input checked="" type="checkbox"/>	☞ \$0.00 Qty: 1	🔧 \$284.99 Job Code: 6115D/4324/25	💰 \$284.99	<input type="checkbox"/>

**2 0 ENGINE** ☞ \$300.00 🔧 \$324.71 💰 \$624.71 🛡️ \$0.00

Electrical System	Declined	Approved	Parts Estimate	Labor Estimate	Total Estimate	Warranty
<b>updated</b> Alternator - Remove & Install Technician Comments:Alternator pulley is bent.	<input type="checkbox"/>	<input checked="" type="checkbox"/>	☞ \$100.00 Qty: 1	🔧 \$238.35 Job Code: 6115D/1405/10	💰 \$338.35	<input type="checkbox"/>
<b>updated</b> Intake System Air filter housing to turbo hose. Technician Comments:Hose is not on the turbo all the way.	<input type="checkbox"/>	<input checked="" type="checkbox"/>	☞ \$200.00 Qty: 1	🔧 \$86.36 Job Code: No Job Code	💰 \$286.36	<input type="checkbox"/>

**7 0 SERVICE ITEMS** ☞ \$745.00 🔧 \$1,048.41 💰 \$1,793.41 🛡️ \$0.00

MFWD Service	Declined	Approved	Parts Estimate	Labor Estimate	Total Estimate	Warranty
<b>updated</b> MFWD axle oil - Service	<input type="checkbox"/>	<input checked="" type="checkbox"/>	☞ \$65.00 Qty: 1	🔧 \$157.18 Job Code: 6115D/4008/29	💰 \$222.18	<input type="checkbox"/>
<b>updated</b> MFWD hub oil (both) - Service	<input type="checkbox"/>	<input checked="" type="checkbox"/>	☞ \$65.00 Qty: 1	🔧 \$189.99 Job Code: 6115D/7728/B/29	💰 \$254.99	<input type="checkbox"/>

	Declined	Approved	Parts Estimate	Labor Estimate	Total Estimate	Warranty
Engine Oil and Filter Engine oil & filter - Change	<input type="checkbox"/>	<input checked="" type="checkbox"/>	🔧 \$150.00 Qty: 1	🔧 \$238.35 Job Code: 6115D/7750/53	👛 \$388.35	<input type="checkbox"/>
Engine Air Filters <b>updated</b> Engine air filters - Change	<input type="checkbox"/>	<input checked="" type="checkbox"/>	🔧 \$160.00 Qty: 1	🔧 \$89.81 Job Code: 6115D/7701/A/53	👛 \$249.81	<input type="checkbox"/>
Fuel Filter Fuel filter (both) - Change	<input type="checkbox"/>	<input checked="" type="checkbox"/>	🔧 \$65.00 Qty: 1	🔧 \$169.27 Job Code: 6115D/7702/B/53	👛 \$234.27	<input type="checkbox"/>
Hydraulic Oil and Filter <b>updated</b> Transmission filter - Change	<input type="checkbox"/>	<input checked="" type="checkbox"/>	🔧 \$180.00 Qty: 1	🔧 \$105.36 Job Code: 6115D/7708/53	👛 \$285.36	<input type="checkbox"/>
Cab Filters <b>updated</b> Cab air filters - Change	<input type="checkbox"/>	<input checked="" type="checkbox"/>	🔧 \$60.00 Qty: 1	🔧 \$98.45 Job Code: 6115D/7717/CAB/53	👛 \$158.45	<input type="checkbox"/>





# Hydroverse Water Meter

## Electromagnetic Flow Measurement System for Commercial and Industrial Applications

Sensus Hydroverse™ water meters deliver industry-leading accuracy, flow range and low-flow sensitivity for commercial and industrial potable, reclaimed and raw water applications. Using proven electromagnetic metering technology, the Hydroverse meter is ideally suited to capture revenue from large commercial accounts, enable district/zone metering and measure export or raw water flow. Benefit from the ease of programming, flexible communication, data storage, power supply options, configurable alarms and minimal head loss provided by this smart commercial water meter.

### BENEFITS

- Wide flow range for greater application flexibility
- Superior low-flow accuracy, even for raw water
- No moving parts minimizes wear and prolongs meter life
- Ease of programming with user-friendly mobile application
- AMI/AMR capable
- Minimal head loss ensures consistent accuracy
- 10-year battery life
- Internal verification for enhanced meter accuracy assurance

### Industry Leading Performance

The Hydroverse water meter offers accuracy of  $\pm 0.4$  percent or optional  $\pm 0.2$  percent over a wide flow range. The internal verification algorithm runs automatically, maintaining accuracy over the life of the meter. Hydroverse Manager Software, the intuitive mobile app available for Android™\* devices, offers easy programmability to ensure meter configuration for optimal performance.

### Solid State Magnetic Technology

The Hydroverse meter uses industry-proven electromagnetic technology that provides superior accuracy for a wider range of flow conditions than most metering technologies available today. With no moving parts, the Hydroverse meter will not suffer accuracy drift due to wear common to other metering technologies. This reduces total cost of ownership through less frequent meter testing and repairs.

### Alarms

The Hydroverse features optional, configurable alarms for low flow, high flow, power supply and system measurement.

# Hydroverse Water Meter

## Electromagnetic Flow Measurement System for Commercial and Industrial Applications

### Construction

The Hydroverse meter consists of a measuring tube and a liner. The measuring tube is made of steel with corrosion-resistant coating. The hard rubber (non-magnetic) liner is resistant to corrosion, aging and abrasion. The Hydroverse meter is IP68 rated to 6 feet.

### Electronic Register

The Hydroverse electronic register is available in integral or remote designs with remote register placement up to 330 feet (100m) away from the meter. The easy-to-read LCD can be configured to display forward, reverse and total consumption, direction of flow, flow rate and alarms. Register output options include Sensus communication

protocol and configurable pulse output. The register is IP68 rated to a depth of 6 feet.

### AMI / AMR Compatibility

Sensus Hydroverse meters are compatible with common AMI / AMR systems, including the Sensus FlexNet® communication network.

### Conformance to Standards

The Hydroverse is NSF Standard 61 compliant. Flanges are ASME B16.5 Standard and Class CL150.

### Dimensions and Weights

Meter and Pipe Size	Low Flow Limit (±1.5% accuracy)		Normal Operating Range (±0.4% or optional ±0.2% accuracy)		Max Intermittent Flow		Flange Outer Diameter (D)	Number of Holes (N)	Bolt Hole Diameter (Y)	Sensor Length (L)	Register Height (F)	Approximate Weight
1-1/2" DN40	0.28 GPM 0.06 m <sup>3</sup> /hr		0.44 - 150 GPM 0.10 - 34 m <sup>3</sup> /hr		188 GPM 43 m <sup>3</sup> /hr		5.9 in 150 mm	4	5/8 in 15.7 mm	7.9 in 200 mm	6.2 in 158 mm	29 lb 13 kg
2" DN50	0.44 GPM 0.10 m <sup>3</sup> /hr		0.70 - 220 GPM 0.16 - 50 m <sup>3</sup> /hr		275 GPM 62 m <sup>3</sup> /hr		6.5 in 165 mm	4	3/4 in 19 mm	7.9 in 200 mm	6.4 in 162 mm	33 lb 15 kg
3" DN80	1.1 GPM 0.25 m <sup>3</sup> /hr		1.8 - 510 GPM 0.40 - 116 m <sup>3</sup> /hr		638 GPM 145 m <sup>3</sup> /hr		7.9 in 200 mm	4	3/4 in 19 mm	7.9 in 200 mm	7.1 in 181 mm	46 lb 21 kg
4" DN100	1.8 GPM 0.4 m <sup>3</sup> /hr		2.8 - 920 GPM 0.64 - 209 m <sup>3</sup> /hr		1,150 GPM 261 m <sup>3</sup> /hr		9.3 in 235 mm	8	3/4 in 19 mm	9.8 in 250 mm	8.0 in 202 mm	59 lb 27 kg
6" DN150	4 GPM 1 m <sup>3</sup> /hr		7 - 2,800 GPM 1.6 - 636 m <sup>3</sup> /hr		3,500 GPM 795 m <sup>3</sup> /hr		11.8 in 300 mm	8	7/8 in 22 mm	11.8 in 300 mm	9.2 in 233 mm	77 lb 35 kg
8" DN200	7 GPM 1.6 m <sup>3</sup> /hr		11 - 3,700 GPM 2.5 - 840 m <sup>3</sup> /hr		4,625 GPM 1,050 m <sup>3</sup> /hr		13.5 in 343 mm	8	7/8 in 22 mm	13.8 in 350 mm	10.2 in 259 mm	150 lb 68 kg
10" DN250	28 GPM 6.4 m <sup>3</sup> /hr		45 - 7,045 GPM 10 - 1,600 m <sup>3</sup> /hr		8,807 GPM 2,000 m <sup>3</sup> /hr		15.9 in 405 mm	12	1 in 26 mm	17.7 in 450 mm	12.6 in 319 mm	154 lb 70 kg
12" DN300	44 GPM 10 m <sup>3</sup> /hr		70 - 11,008 GPM 16 - 2,500 m <sup>3</sup> /hr		13,760 GPM 3,125 m <sup>3</sup> /hr		19.1 in 485 mm	12	1 in 26 mm	19.7 in 500 mm	13.5 in 342 mm	231 lb 105 kg
14" DN350	70 GPM 16 m <sup>3</sup> /hr		113 - 17,613 GPM 26 - 4,000 m <sup>3</sup> /hr		22,017 GPM 5,000 m <sup>3</sup> /hr		21.1 in 535 mm	12	1 1/8 in 29 mm	21.7 in 550 mm	14.1 in 357 mm	302 lb 137 kg
16" DN400	92 GPM 21 m <sup>3</sup> /hr		148 - 22,897 GPM 34 - 5,200 m <sup>3</sup> /hr		28,622 GPM 6,500 m <sup>3</sup> /hr		23.6 in 600 mm	12	1 1/8 in 29 mm	23.6 in 600 mm	15.7 in 399 mm	385 lb 175 kg
18" DN450	111 GPM 25 m <sup>3</sup> /hr		178 - 27,741 GPM 40 - 6,300 m <sup>3</sup> /hr		34,676 GPM 7,875 m <sup>3</sup> /hr		25.0 in 635 mm	16	1 1/4 in 32 mm	23.6 in 600 mm	16.0 in 407 mm	550 lb 250 kg
20" DN500	137 GPM 31 m <sup>3</sup> /hr		218 - 33,906 GPM 50 - 7,700 m <sup>3</sup> /hr		42,382 GPM 9,625 m <sup>3</sup> /hr		27.6 in 700 mm	20	1 1/4 in 32 mm	23.6 in 600 mm	16.0 in 407 mm	660 lb 300 kg
24" DN600	176 GPM 40 m <sup>3</sup> /hr		282 - 44,033 GPM 64 - 10,000 m <sup>3</sup> /hr		55,042 GPM 12,500 m <sup>3</sup> /hr		32.1 in 815 mm	20	1 3/8 in 35 mm	31.5 in 800 mm	18.0 in 458 mm	935 lb 425 kg

Larger sizes are available. Ask your Sensus representative for details.

# Hydroverse Water Meter

## Electromagnetic Flow Measurement System for Commercial and Industrial Applications

Hydroverse:  
1½" - 8"

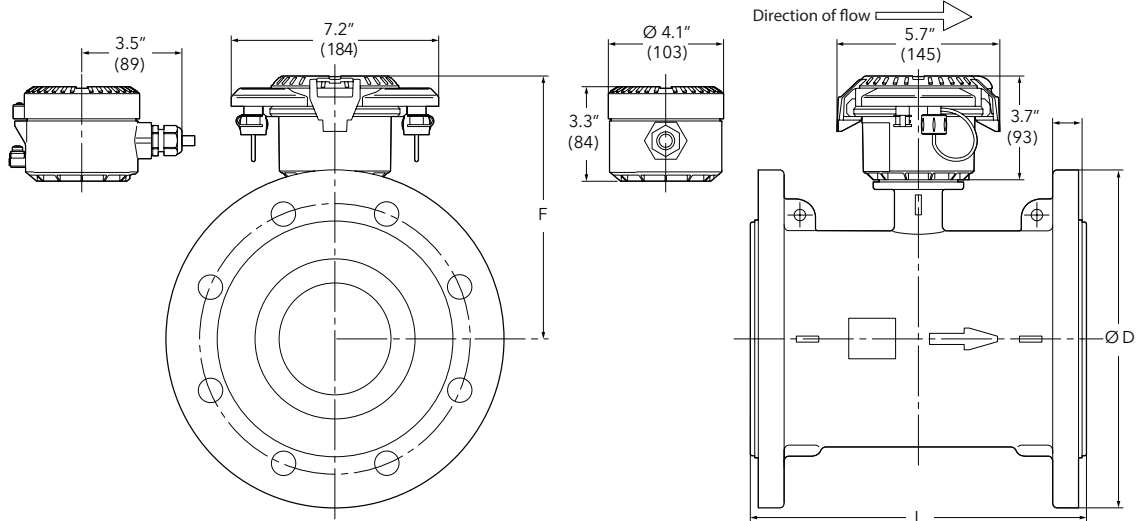

Hydroverse:  
10" - 16"

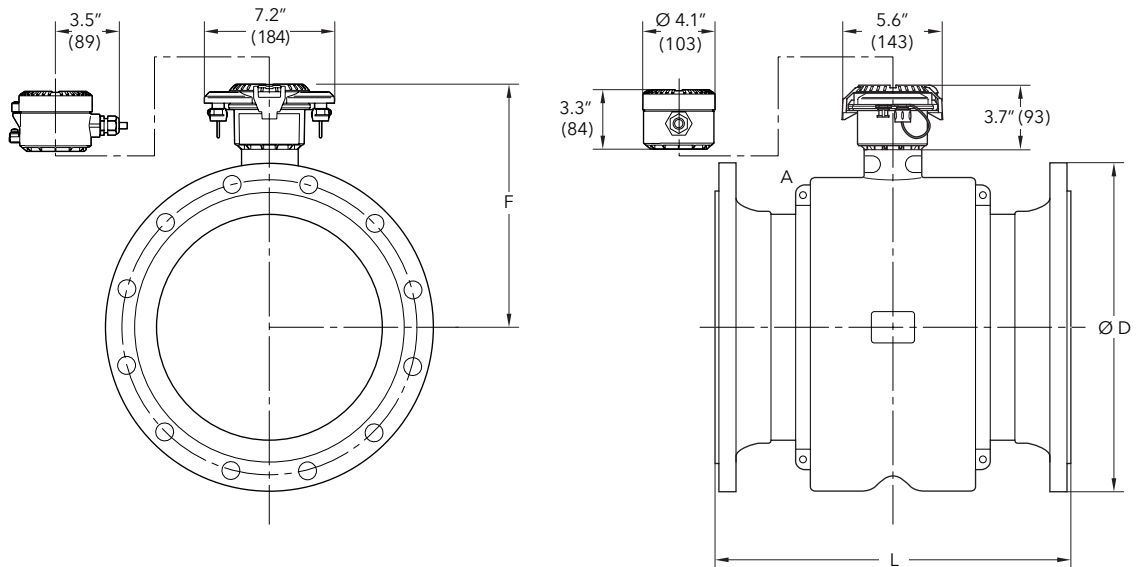

Hydroverse:  
18" - 24"

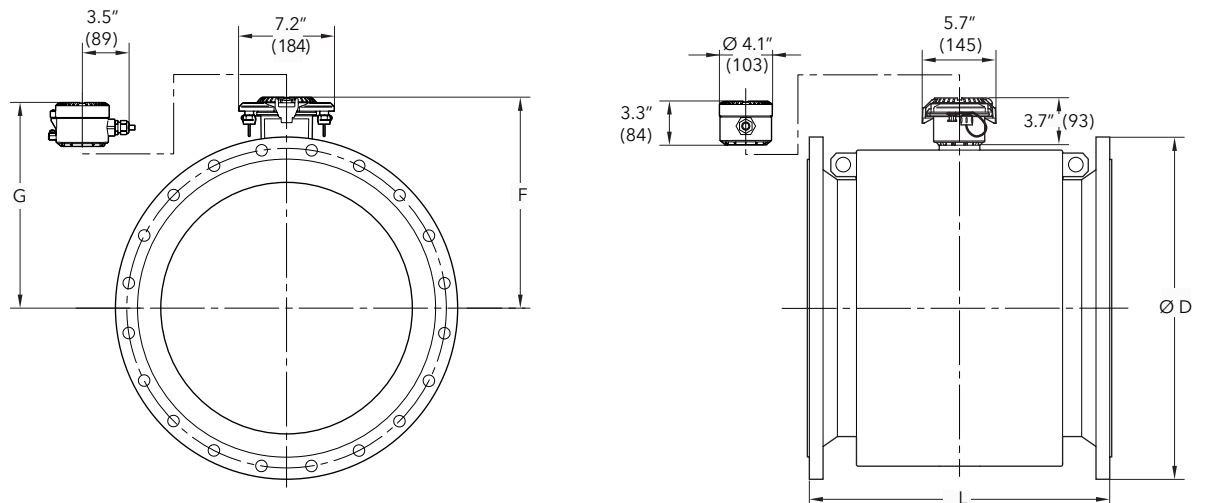

# Hydroverse Water Meter

## Electromagnetic Flow Measurement System for Commercial and Industrial Applications

### Head Loss Curves

Head loss curves are applicable to 1.5" to 8" reduced bore meters. 10" and larger meters are full bore and exhibit negligible head loss across the meter.

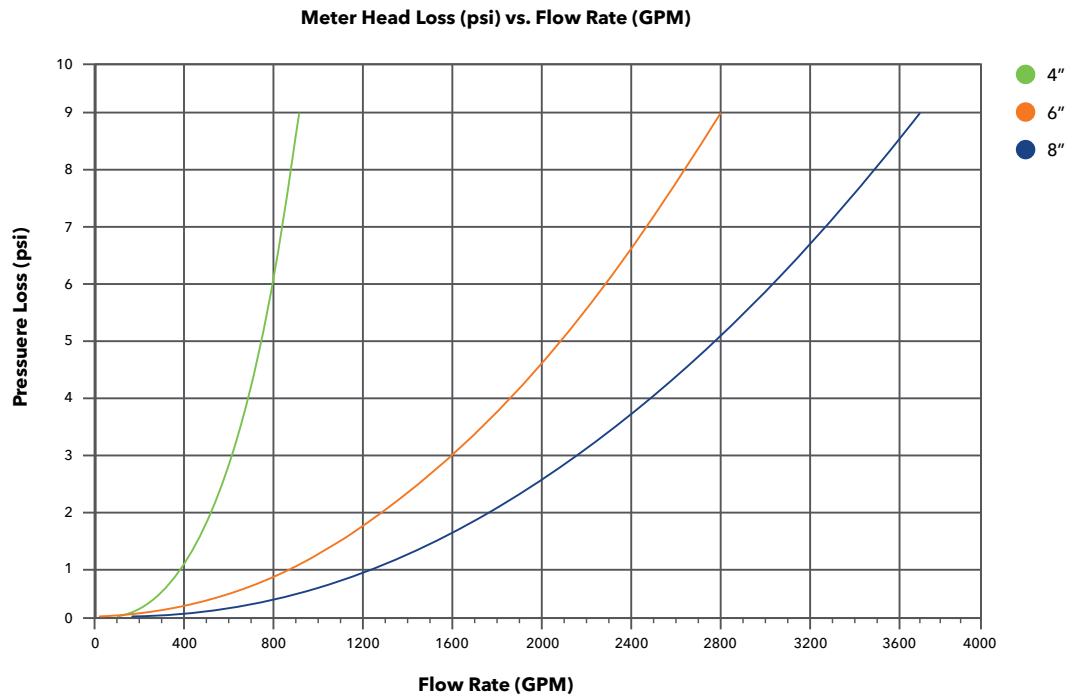
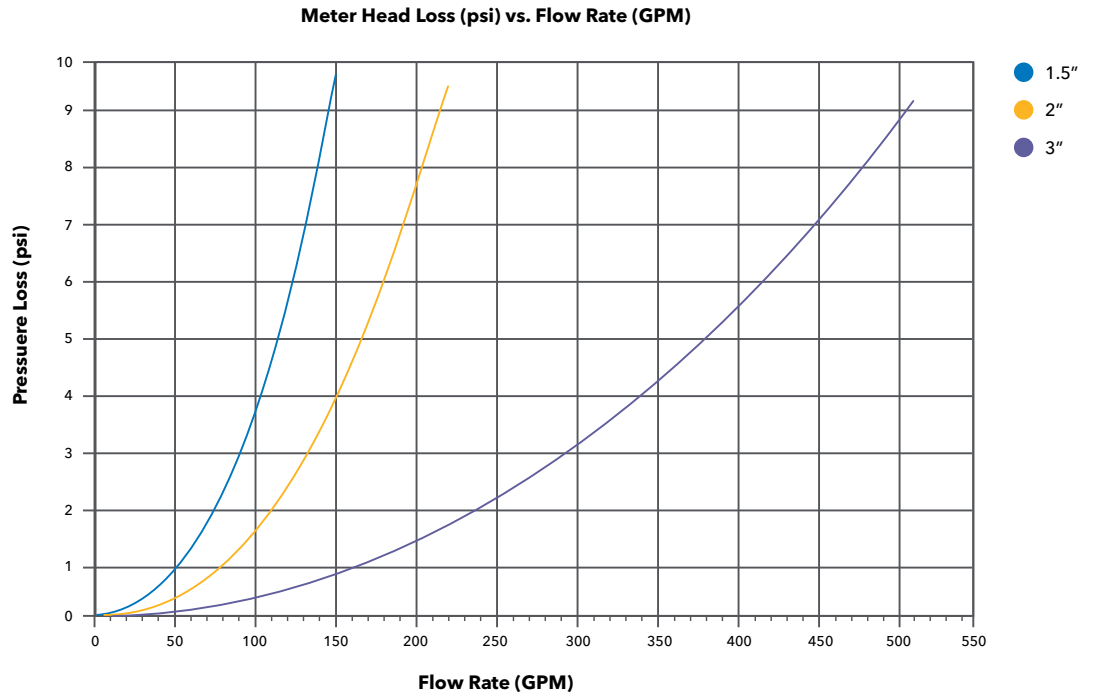

8601 Six Forks Rd, Ste 700  
 Raleigh, NC 27615  
 1-800-638-3748  
 sensus.com

\*Android is a trademark of Google LLC.

©2018 Sensus. All products purchased and services performed are subject to Sensus' terms of sale, available at either [sensus.com/TC](http://sensus.com/TC) or 1-800-638-3748. Sensus reserves the right to modify these terms and conditions in its own discretion without notice to the customer. The Sensus logo is a registered trademark of Sensus.

This document is for informational purposes only, and SENSUS MAKES NO EXPRESS WARRANTIES IN THIS DOCUMENT. FURTHERMORE, THERE ARE NO IMPLIED WARRANTIES, INCLUDING WITHOUT LIMITATION, WARRANTIES AS TO FITNESS FOR A PARTICULAR PURPOSE AND MERCHANTABILITY. ANY USE OF THE PRODUCTS THAT IS NOT SPECIFICALLY PERMITTED HEREIN IS PROHIBITED.



To: Anthony City Commission

Re: Chief of Police report

From: Kenny Hodson

Date: 01-02-2024

We investigated the theft of a motor vehicle in the 400 block of E. Main. We found the car an hour later parked in the 300 block of S. Springfield.

We investigated a theft of a motor vehicle from the 200 block of S. Franklin. We found someone driving it a short time later and arrested Robert Lambert for theft.

We investigated a trespassing case and turned it over to the C.A. for possible charges.

We investigated an attempted theft in the 300 block of S. Franklin.

We investigated a burglary and theft in the 300 block of S. Anthony.

We are investigating a case of aggravated indecent liberties with a child.